



ASSEMBLY INSTRUCTIONS
INSTRUCTIONS D'ASSEMBLAGE
INSTRUCCIONES DE ENSAMBLAJE



WARRANTY
GARANTIE
GARANTÍA

Model/ Modèle/ Modelo

Pure black
-3107- *Noir solide*
Negro puro

Article/ Item/ Artículo

Storage Platform Bed 54"/60"
-217- *Lit plate-forme à rangement 137/152 cm*
Cama plataforma con almacenamiento 54"/60"

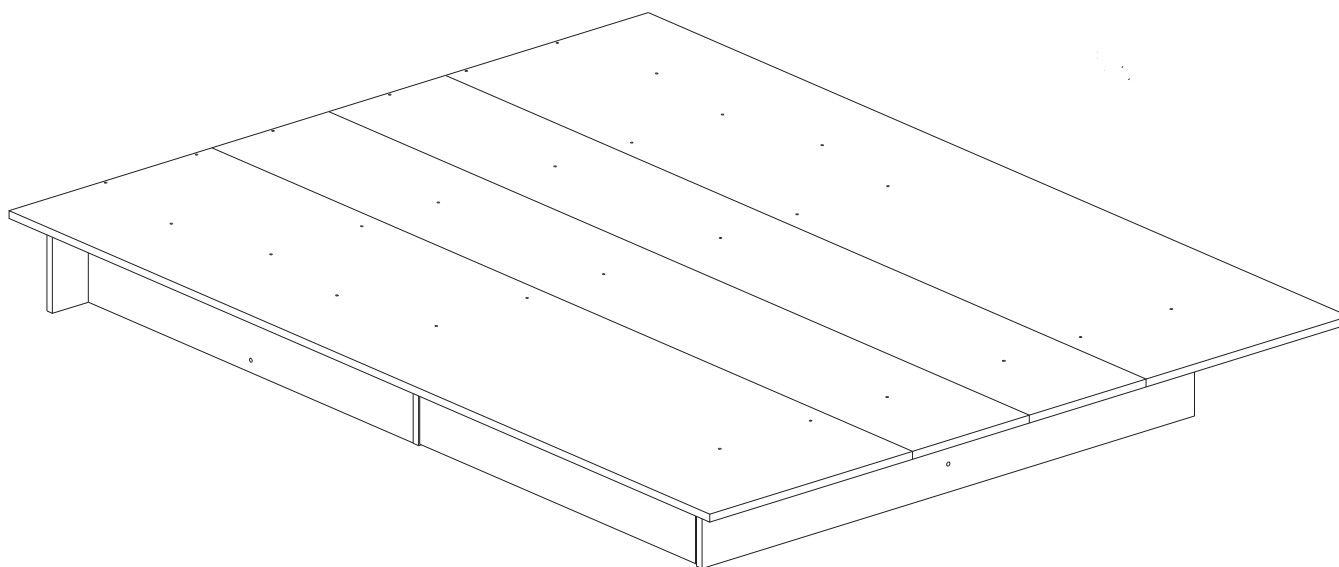

☎ 1-800-290-0465 ☎

22/08/2011

Rev.: Bi6

10015241



ADULT ASSEMBLY REQUIRED
DOIT ÊTRE ASSEMBLÉ PAR UN ADULTE
DEBE SER ENSAMBLADO POR UN ADULTA

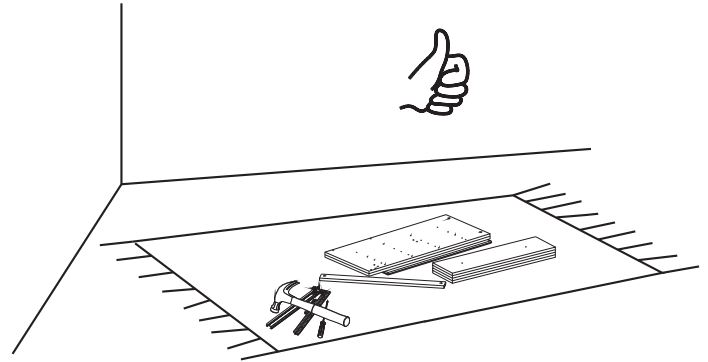
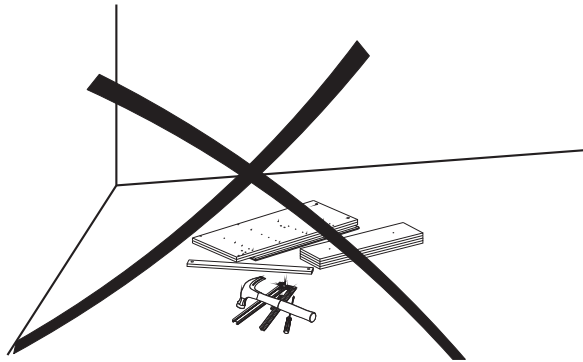
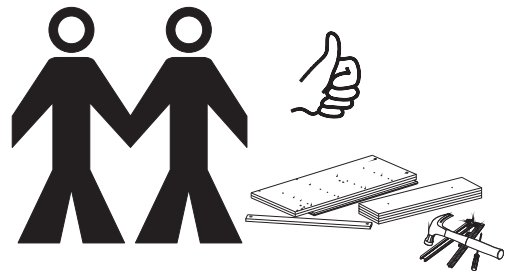

* TOOLS REQUIRED/OUTILS REQUIS/HERRAMIENTAS REQUERIDOS:

- HAMMER/MARTEAU/MARTILLO

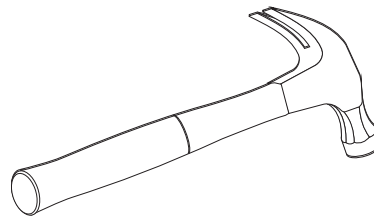

- PHILLIPS/ÉTOILE/ESTRELLA

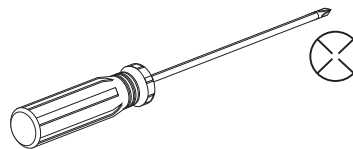

OR/OU/O



- ROBERTSON #1 and #2

- CARRÉ #1 et #2

- CUADRADO #1 y #2

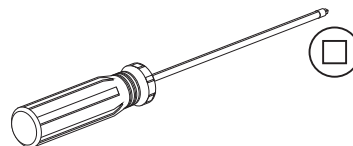

3107-217

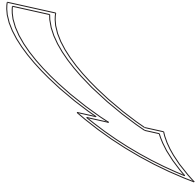
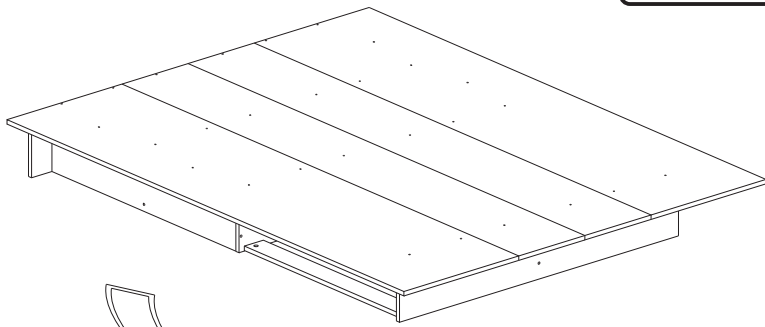

RIGHT SIDE
CÔTÉ DROIT
LADO DERECHO

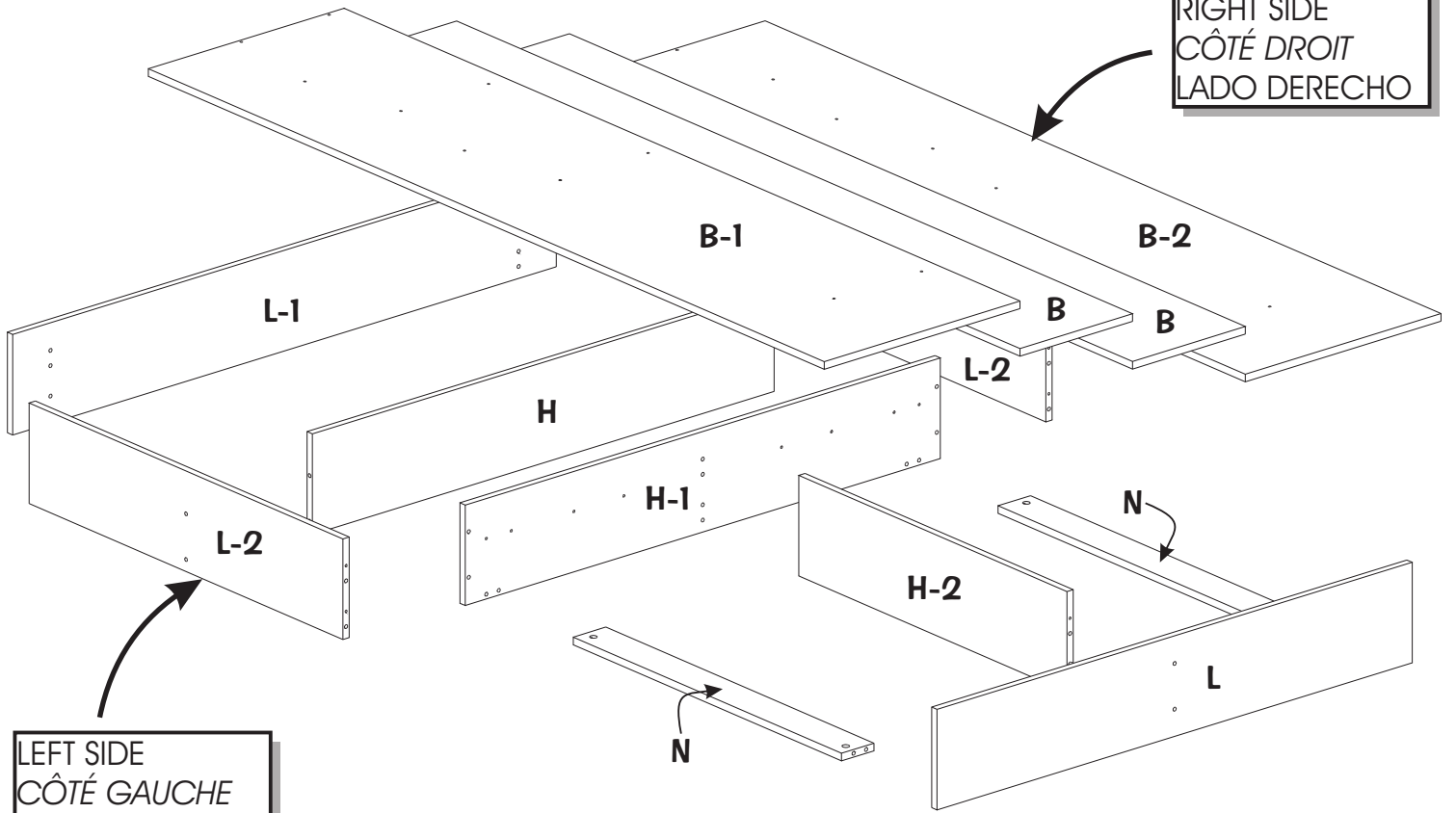



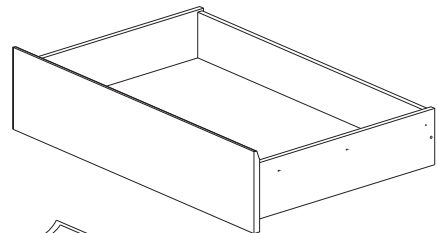
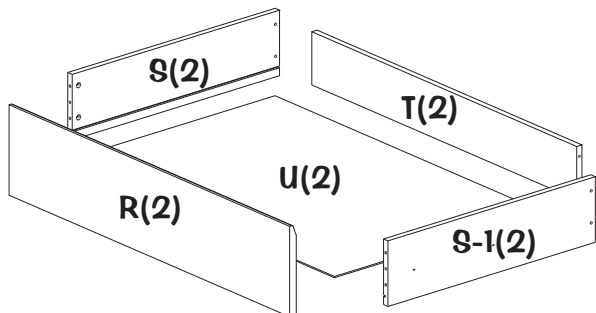





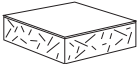
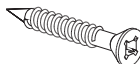

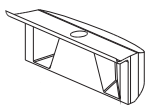
LEFT SIDE
CÔTÉ GAUCHE
LADO IZQUIERDO

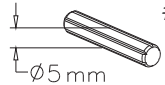

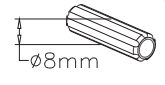
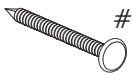
2x Drawers
Tiroirs
Cajones

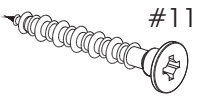
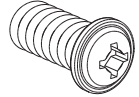
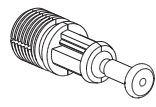
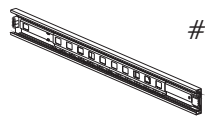
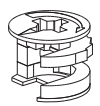
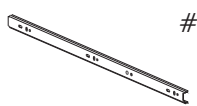
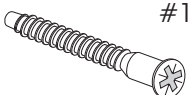
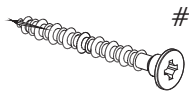
HARDWARE / QUINCAILLERIE / FERRETERÍA

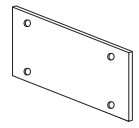
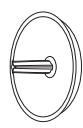
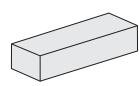
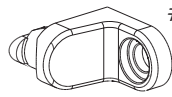
10X	 #6	2X	 #227
16X	 #92	2X	 #228
12X	 #99	4X	 #229 ∅5 mm
12X	 #101	23X	 #231 ∅8 mm
12X	 #106	8X	 #242
8X	 #111	8X	 #278
4X	 #144	4X	 #295
4X	 #158	4X	 #296
12X	 #160	28X	 #299
19X	 #169	3X	 #335
3X	 #170	2X	 #Z-01
8X	 #184		

1

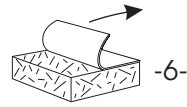

X10

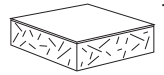

-6-

Pull the paper off.
Enlever le papier.
Quitar el papel.

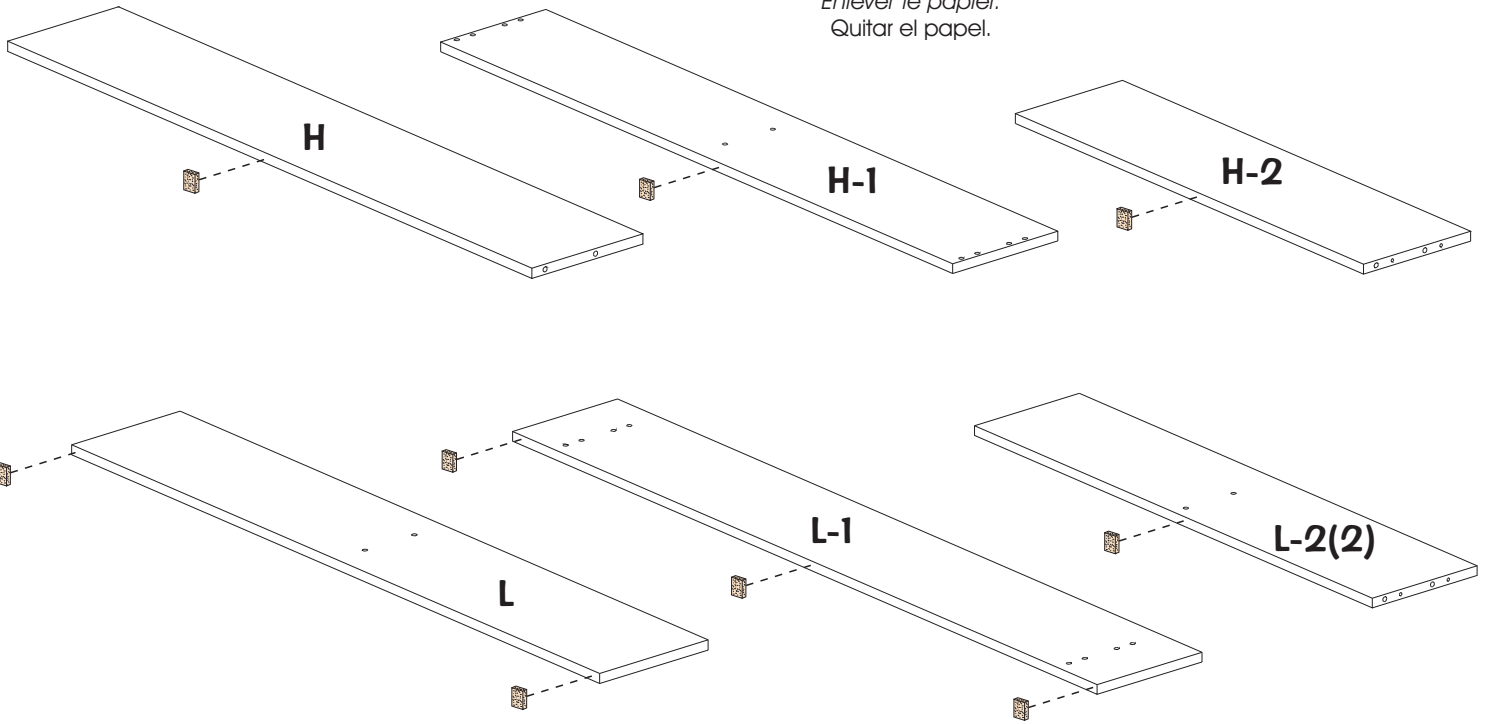

2

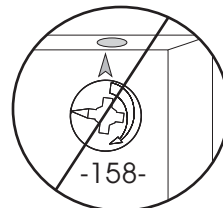
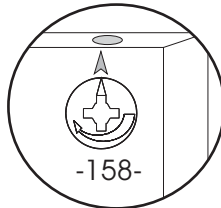
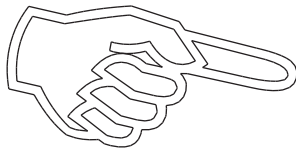

X4

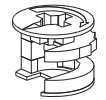

-158-

X20

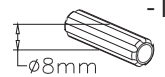

-158-

∅8mm

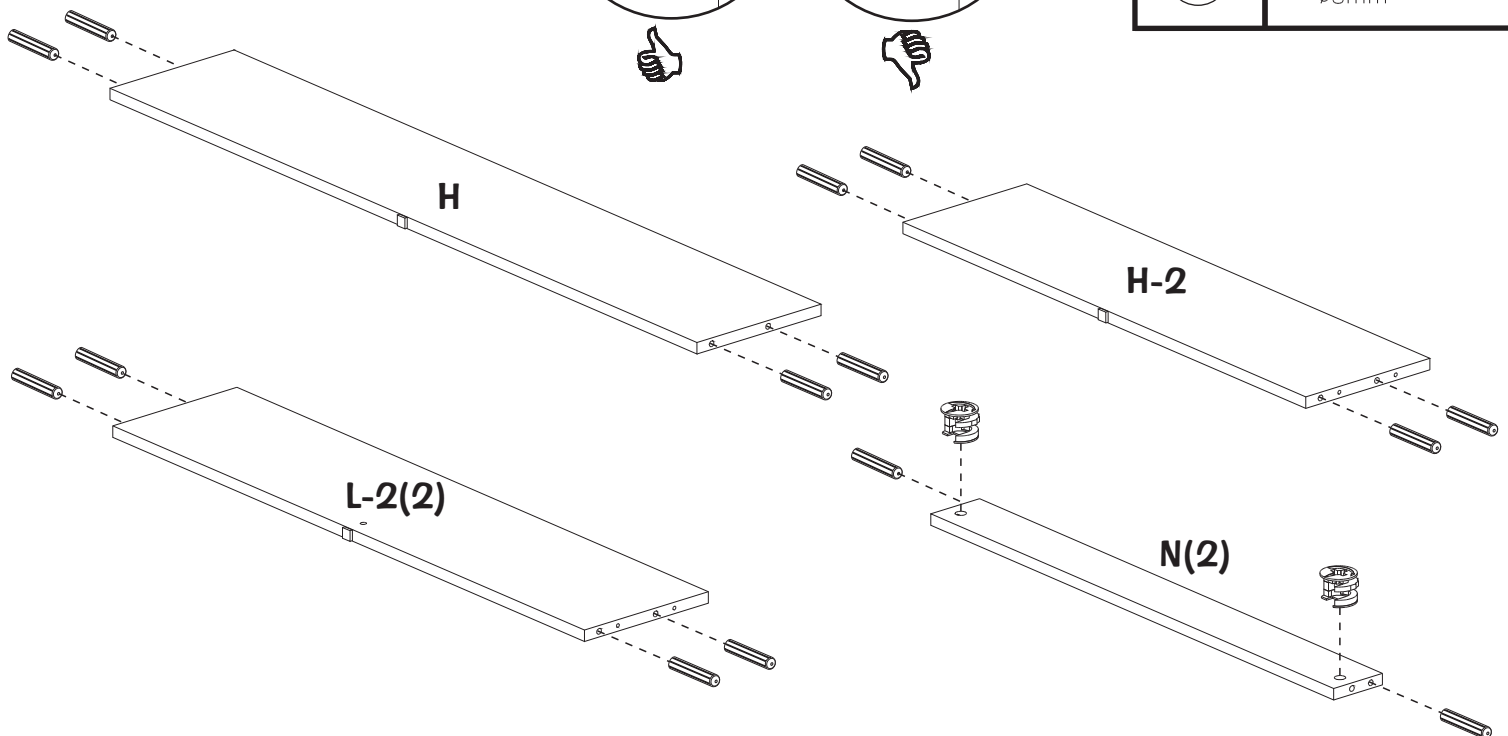

3

X4

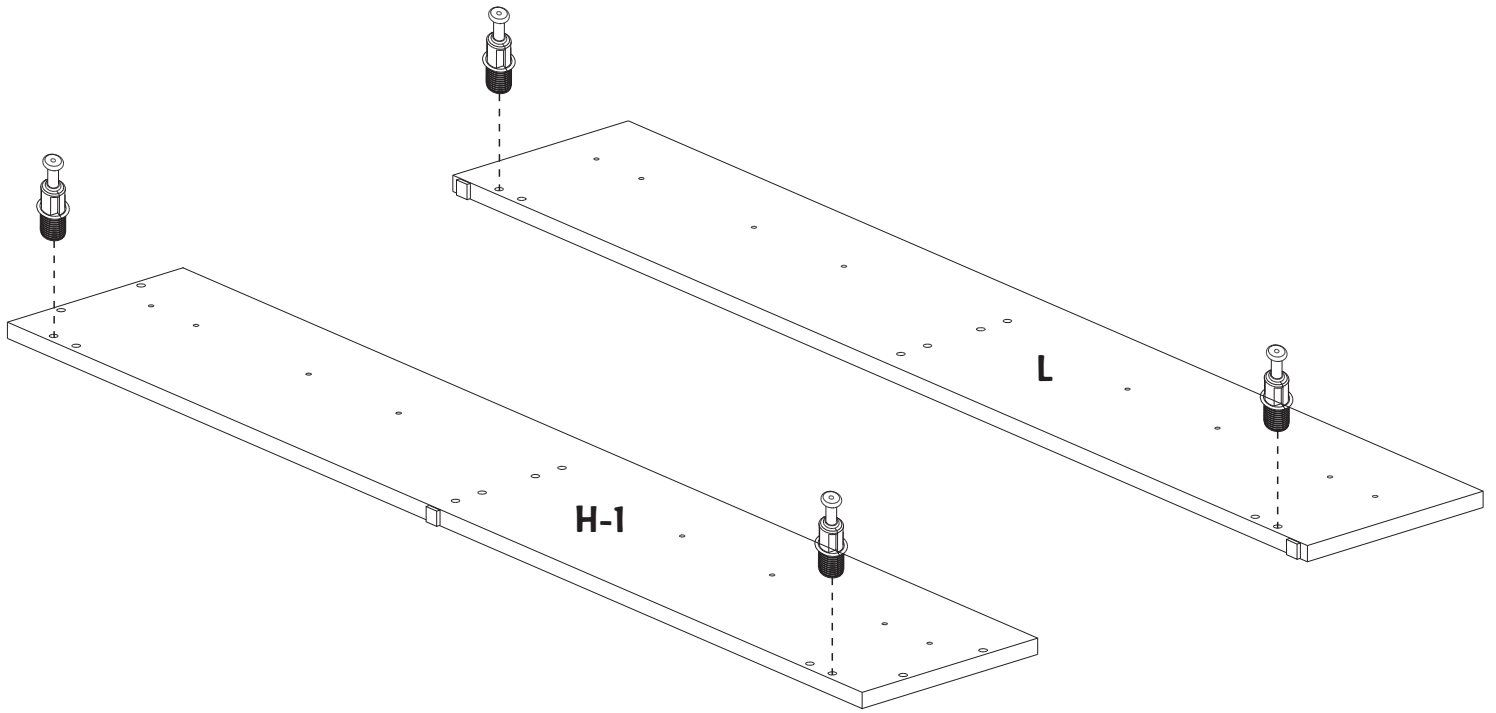
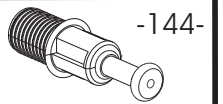

4

-Warning: Push to separate the drawer slide.
-Attention: Pousser pour séparer la coulisse.
-Advertencia: Pulsar para separar la corredera.

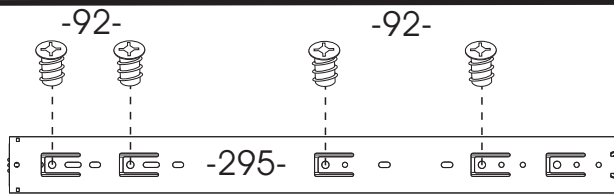

X16



-158-

X4

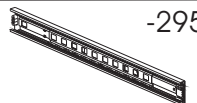

-295-

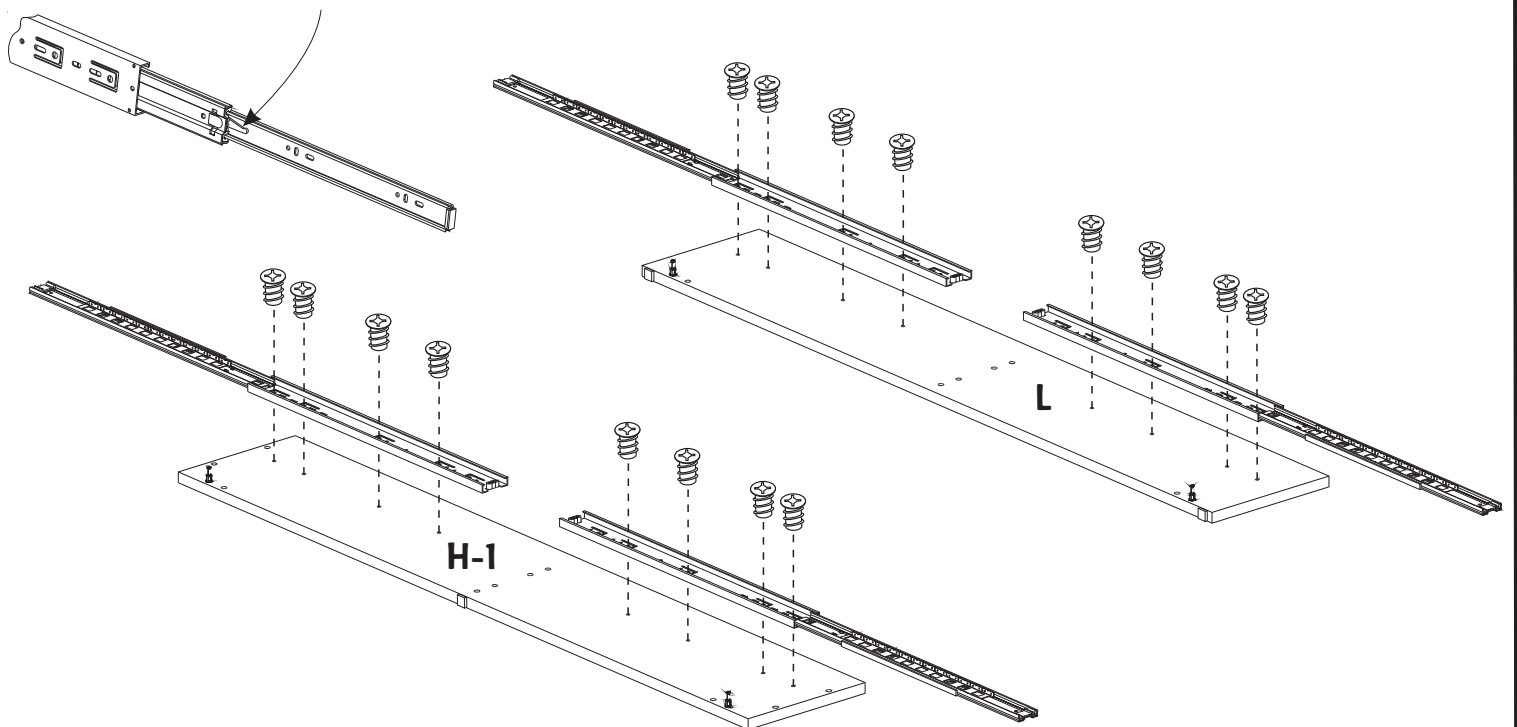

5

X2

-160-

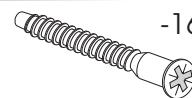

- Finished face
- Surface finie
- Cara terminada

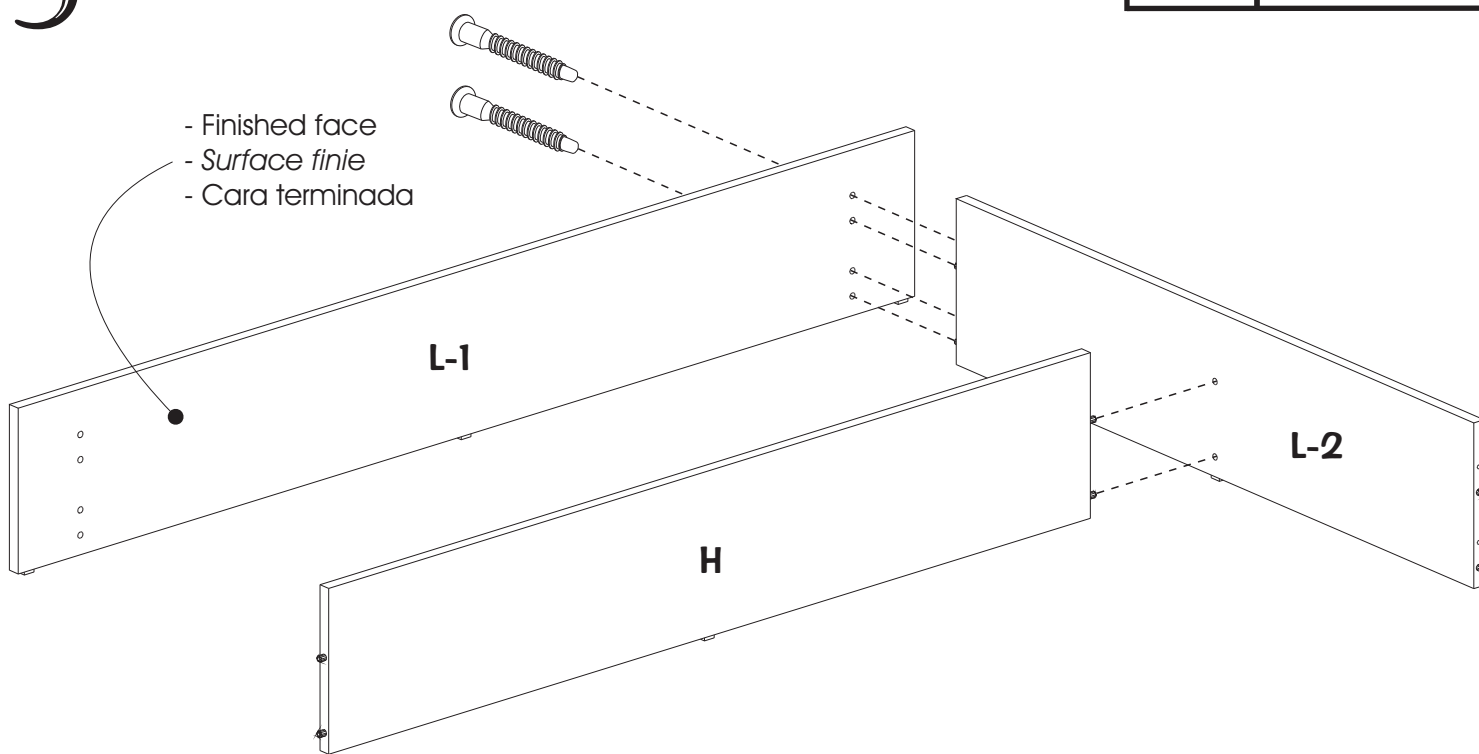

6

X2

-160-

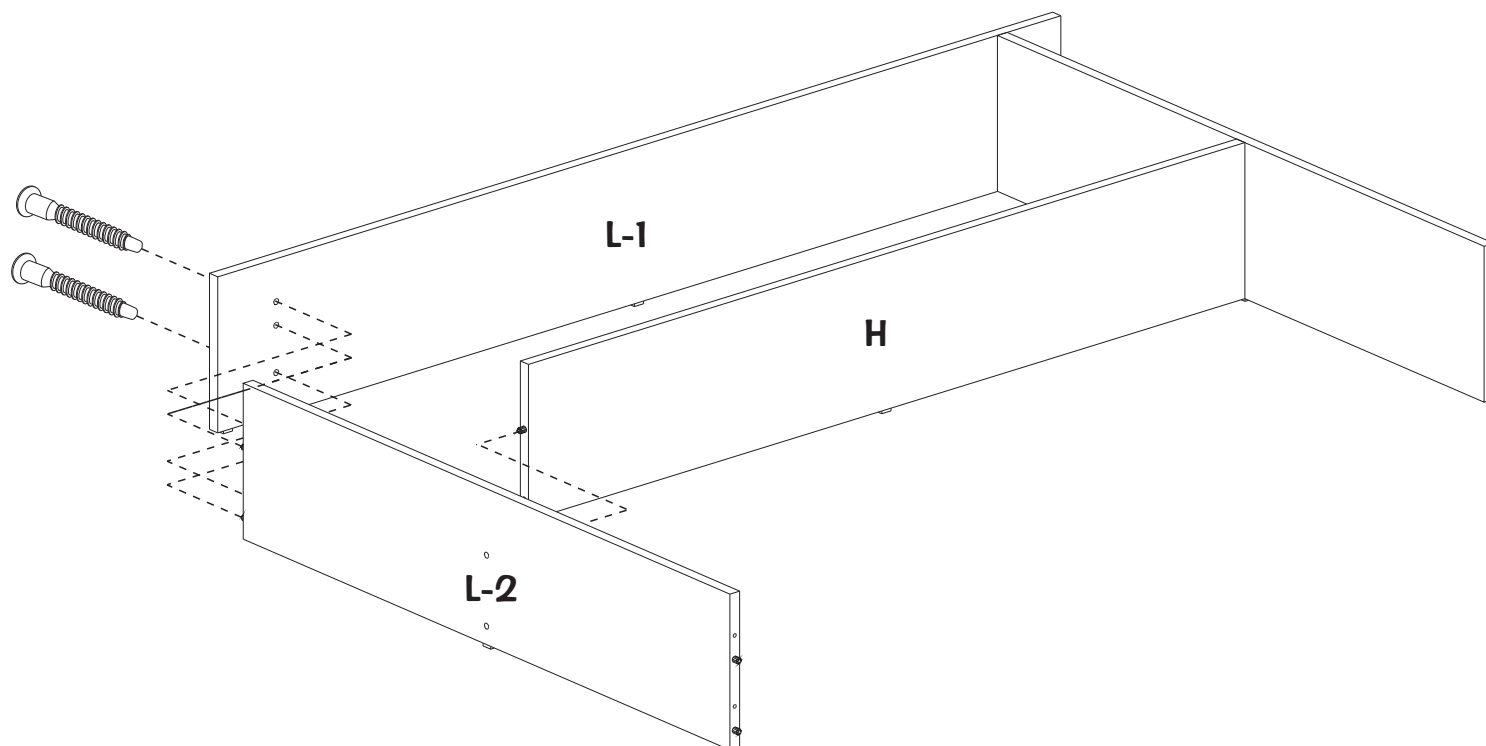
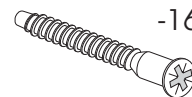

7

X4

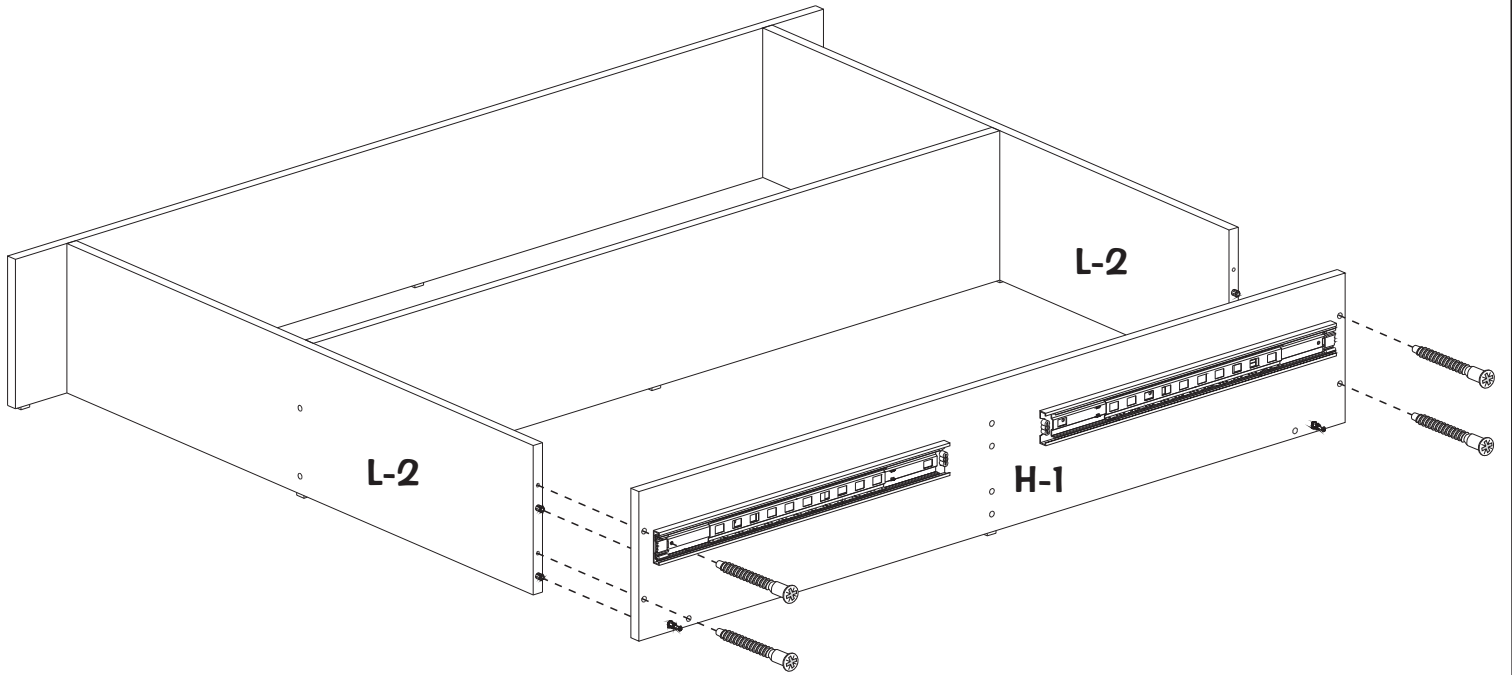
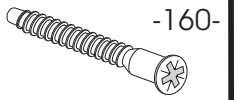

8

X2

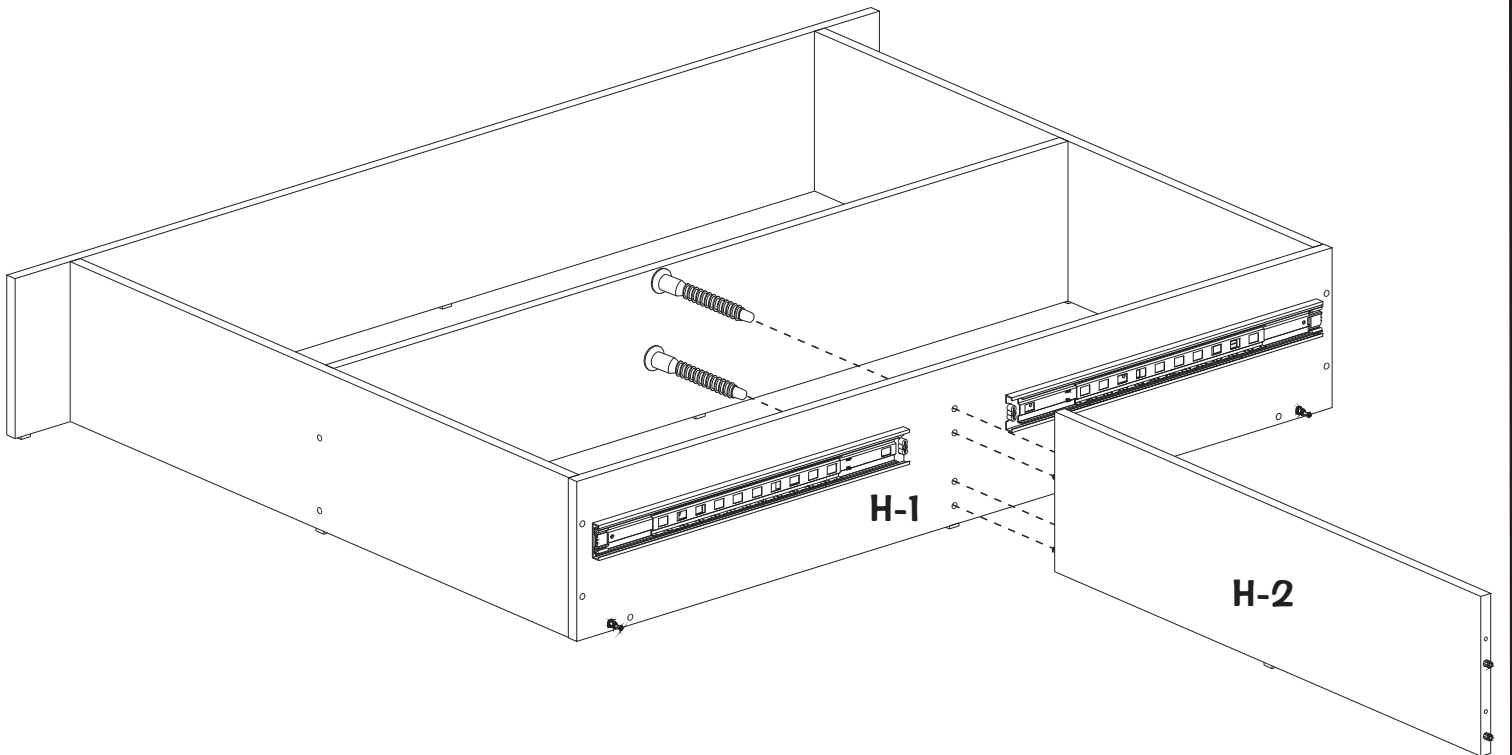
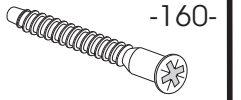

9

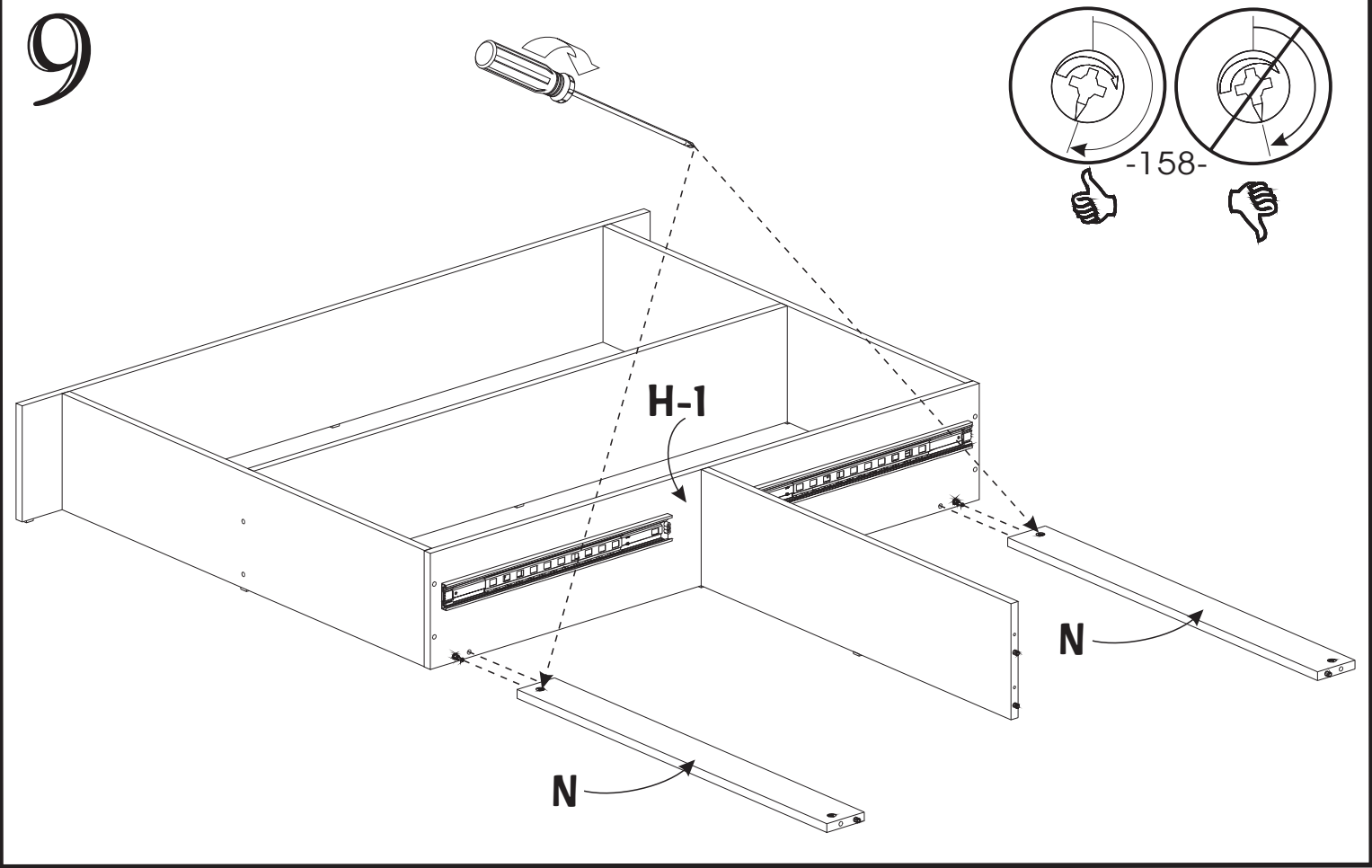

10

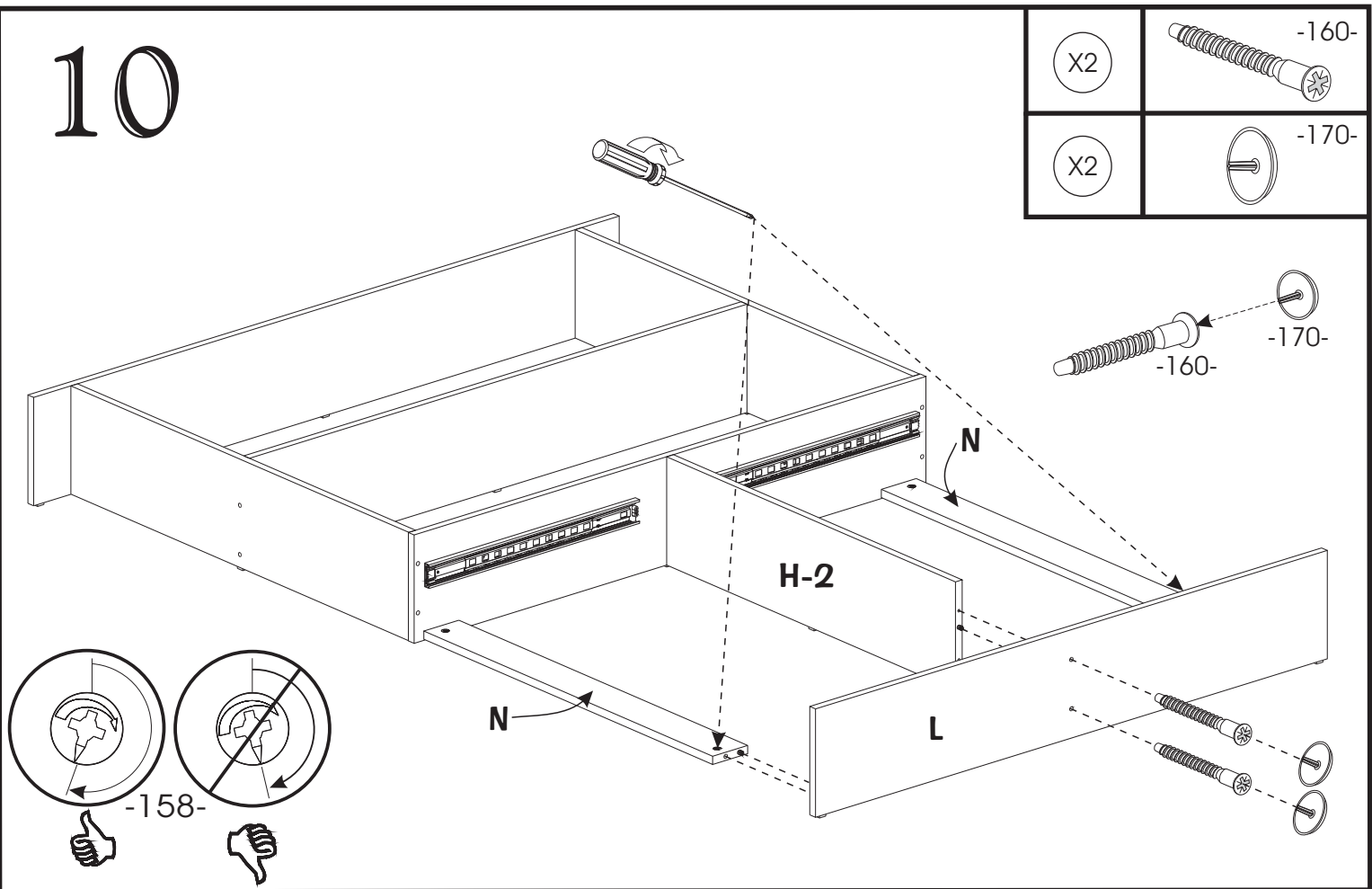

11

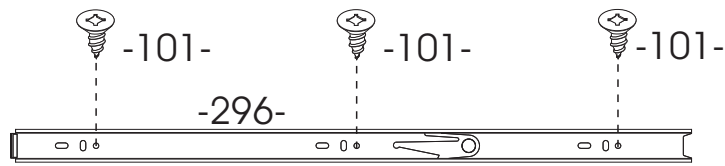

X12

-101-

X4

-296-

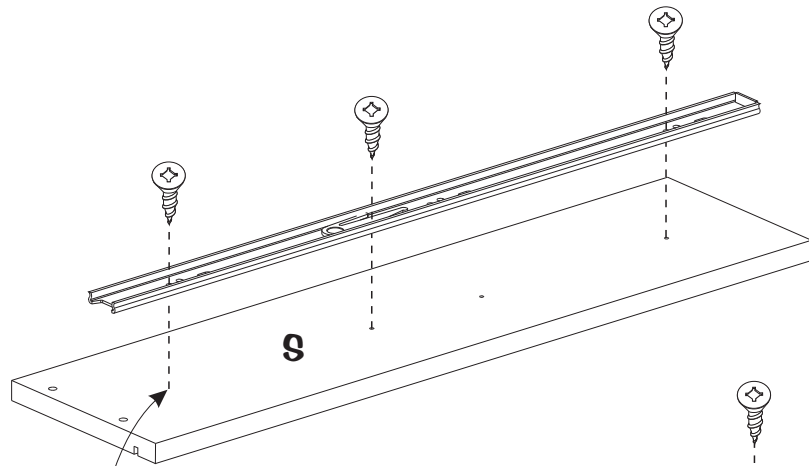

Not pre-drilled hole
Trou non pré-percé
Orificio no preagujereado

2x Drawers
Tiroirs
Cajones

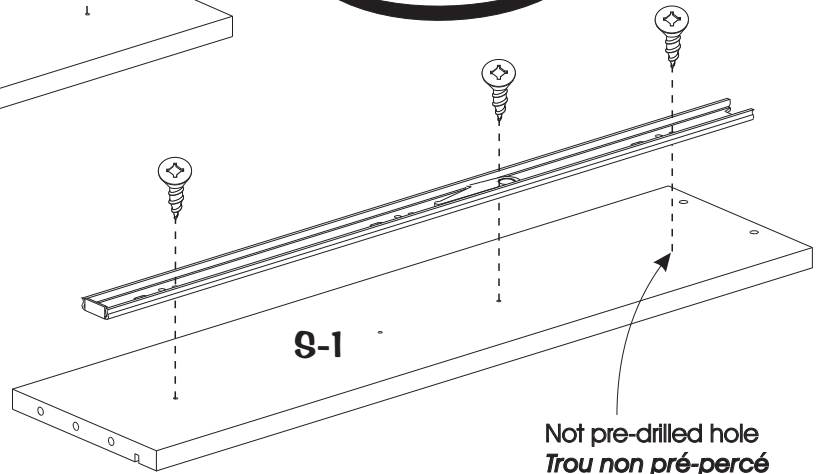

Not pre-drilled hole
Trou non pré-percé
Orificio no preagujereado

12

X4

-229-

2x Drawers
Tiroirs
Cajones

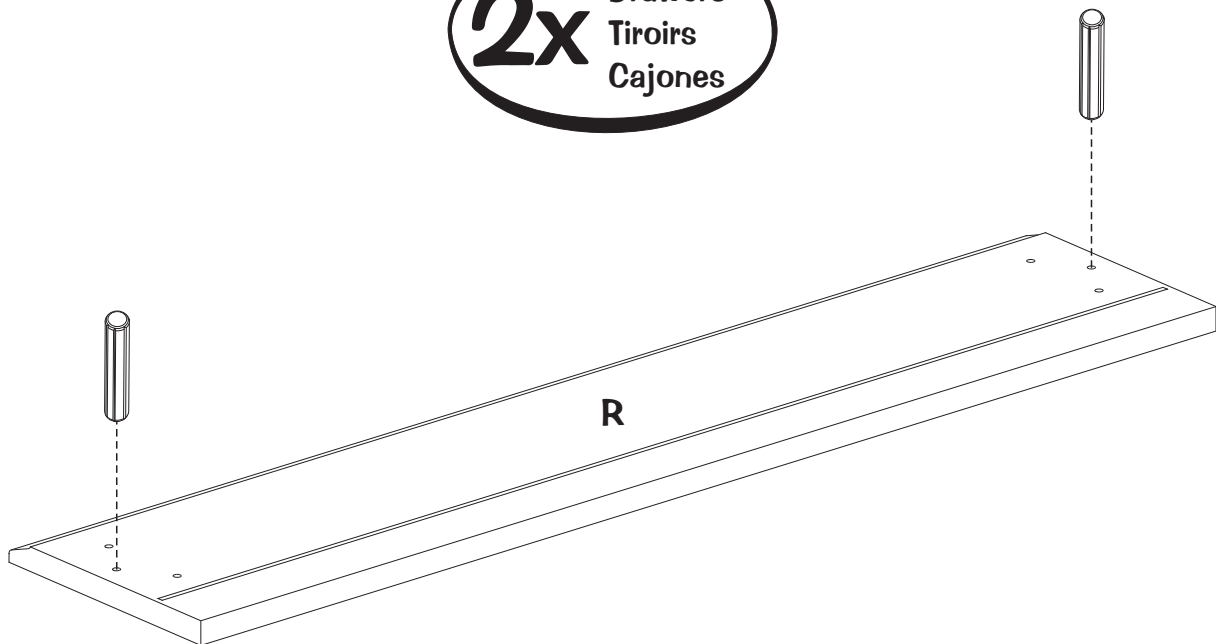

13

X8



-242-

2x Drawers
Tiroirs
Cajones

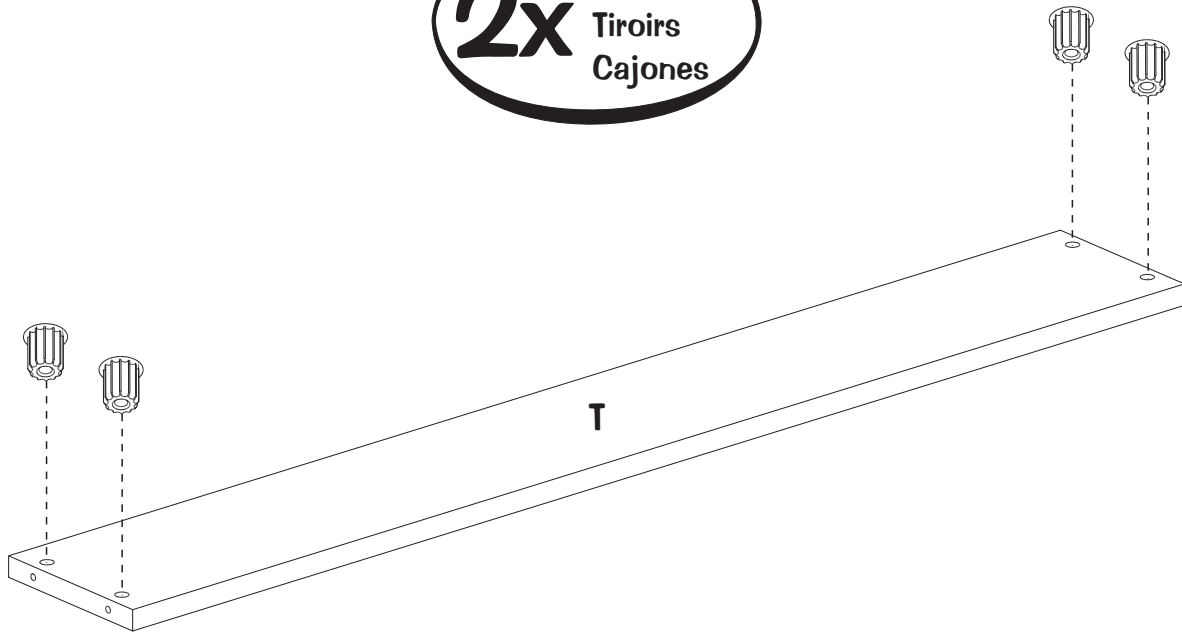

14

X8

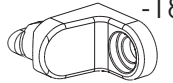

-184-

2x Drawers
Tiroirs
Cajones

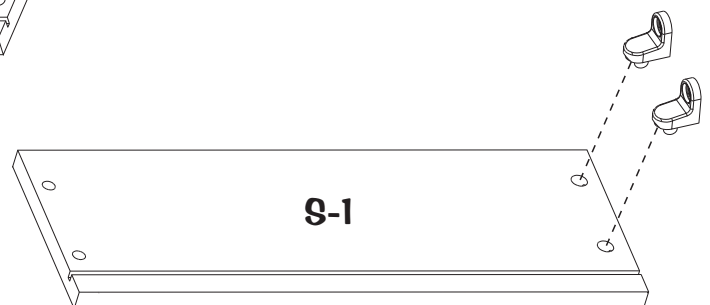
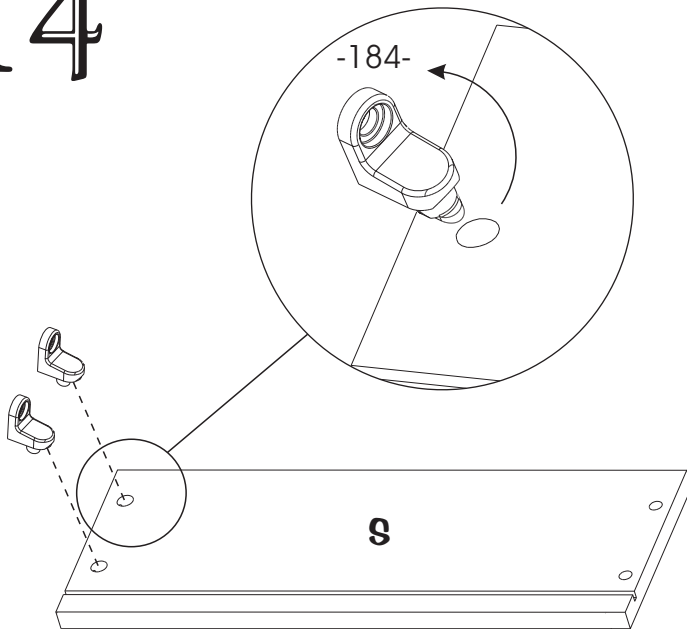

15

2x Drawers
Tiroirs
Cajones

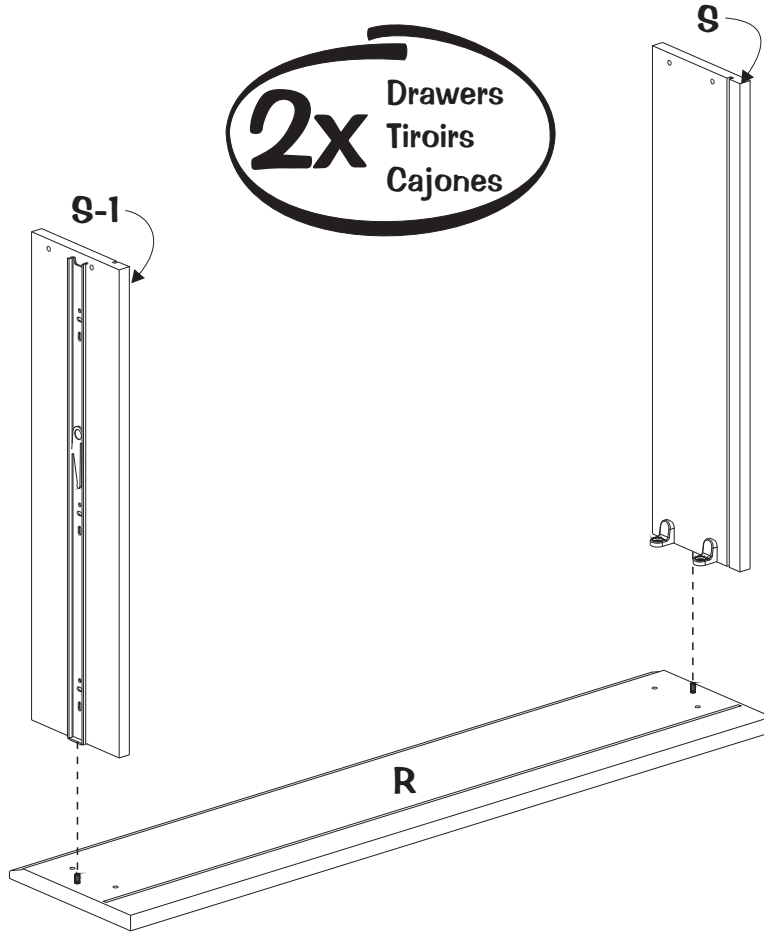

16

X8

-278-

2x Drawers
Tiroirs
Cajones

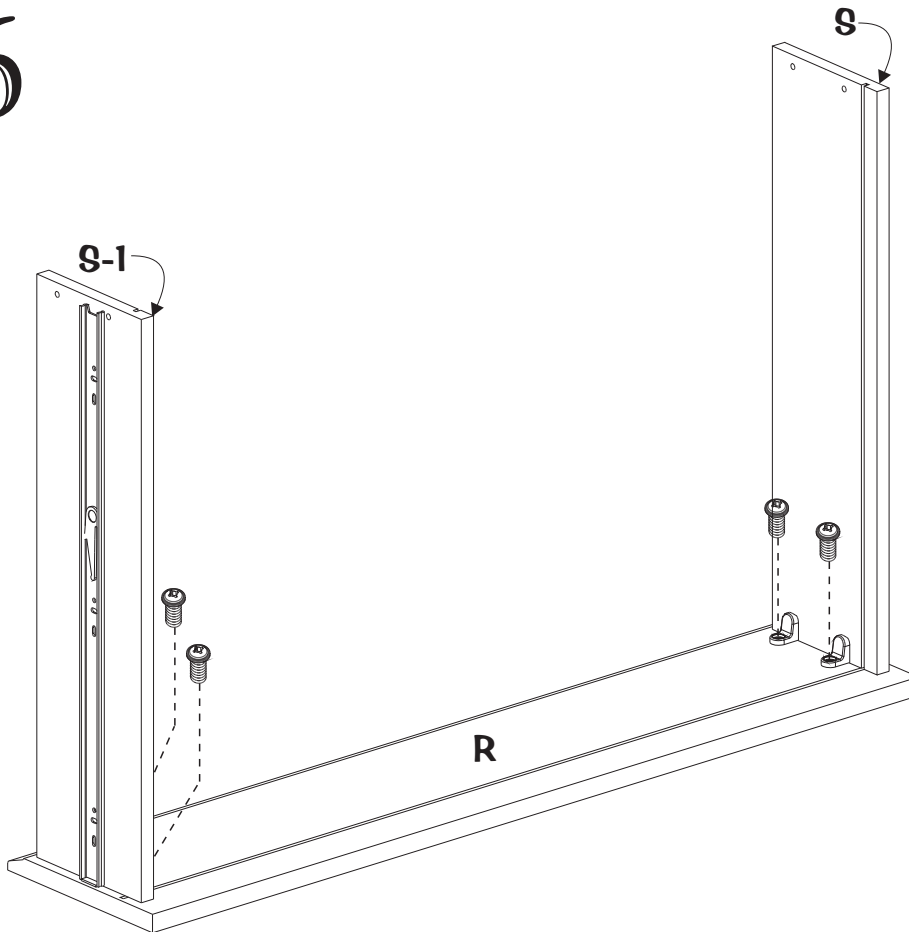

17

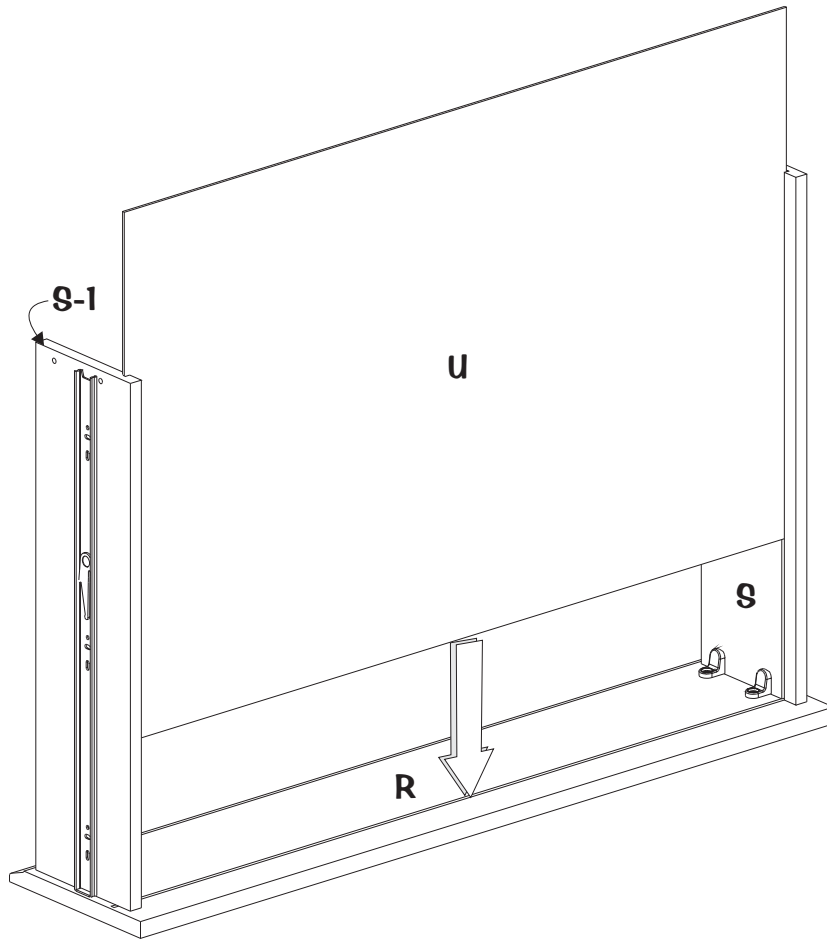

2x Drawers
Tiroirs
Cajones

18

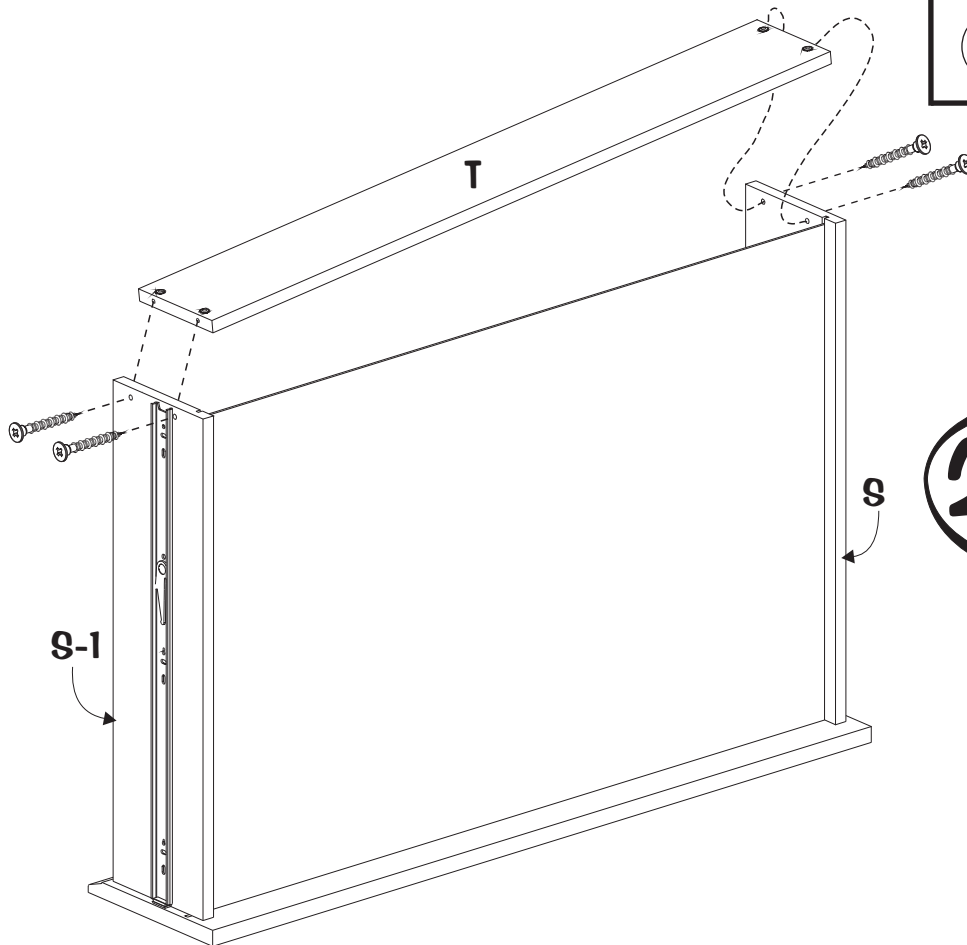

X8

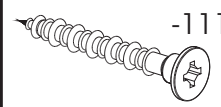

-111-

2x Drawers
Tiroirs
Cajones

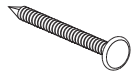

2x Drawers
Tiroirs
Cajones

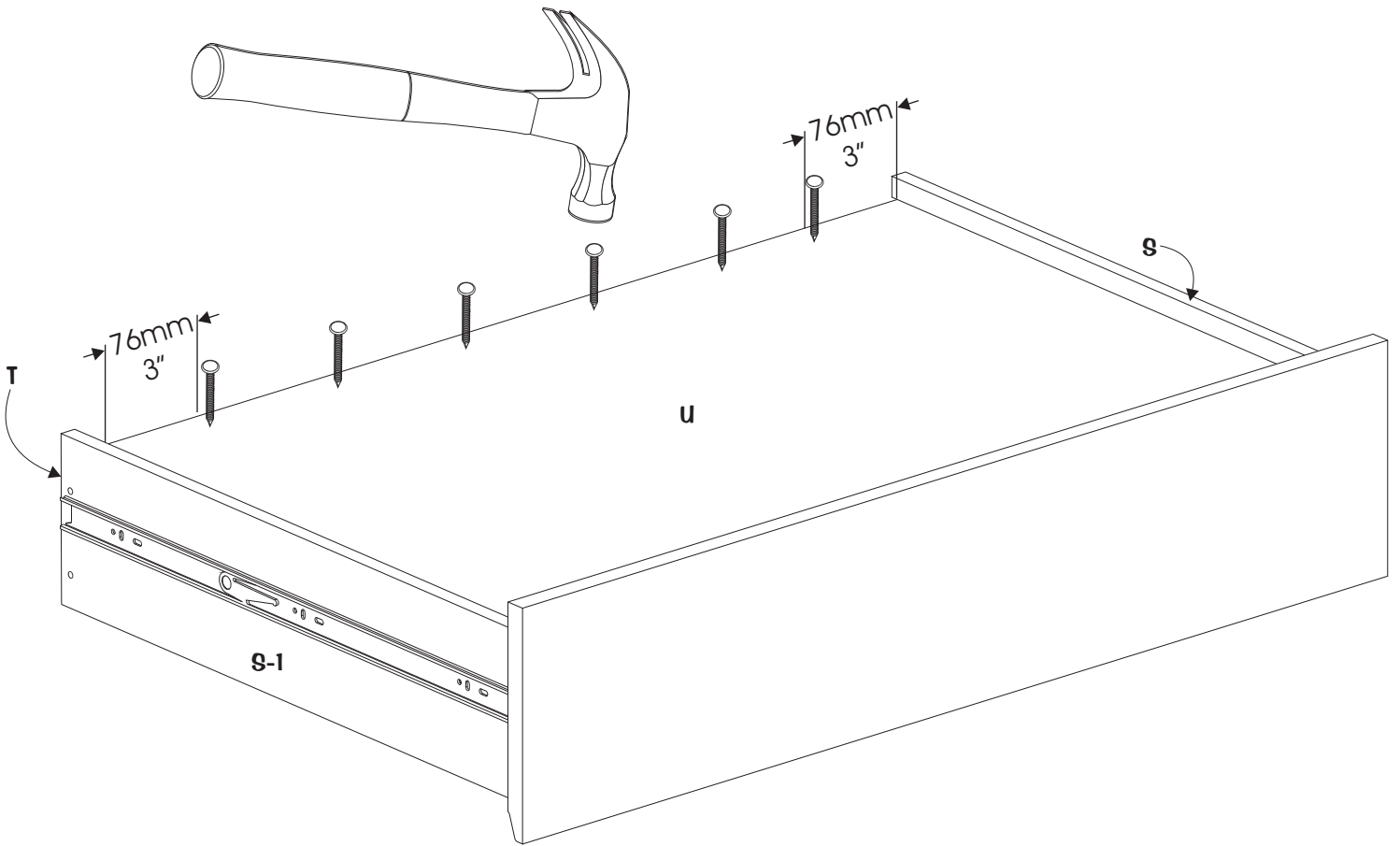

ENGLISH

- #1 - Put the drawer upside down with the back toward yourself.
- #2 - Slide -228- into the groove of R with your thumbs or a hammer.
- #3 - **Important:** Make sure that -228- is completely flush with R and U before inserting screw.
- #4 - Screw -227- through -228- into R, holding R with your hand.

FRANÇAIS

- #1 - Positionner le tiroir à l'envers avec le dos vers soi.
- #2 - Enfoncer -228- dans la rainure de R avec les pouces ou un marteau.
- #3 - **Important:** S'assurer que -228- est complètement appuyé sur R et U avant de visser.
- #4 - Visser -227- à travers -228- dans R en retenant R avec une main.

ESPAÑOL

- #1 - Coloque el cajón al revés con su espalda hacia ti.
- #2 - Rodar -228- en la ranura de R con los pulgares o un martillo.
- #3 - **Importante** : Asegurarse que -228- está completamente apoyado a R y a U antes de atornillar.
- #4 - Atornillar -227- a través de -228- dentro de R, reteniendo R con una mano.

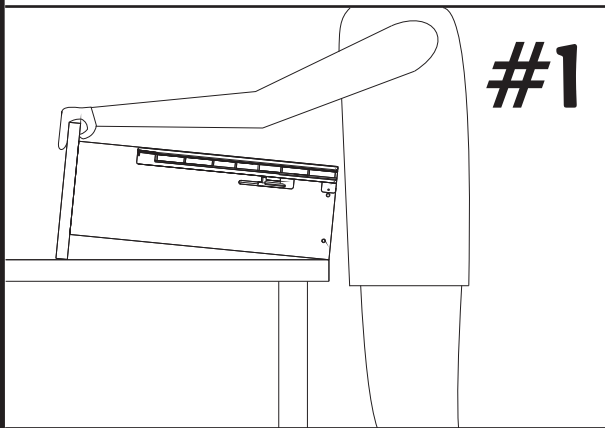

2x Drawers
Tiroirs
Cajones

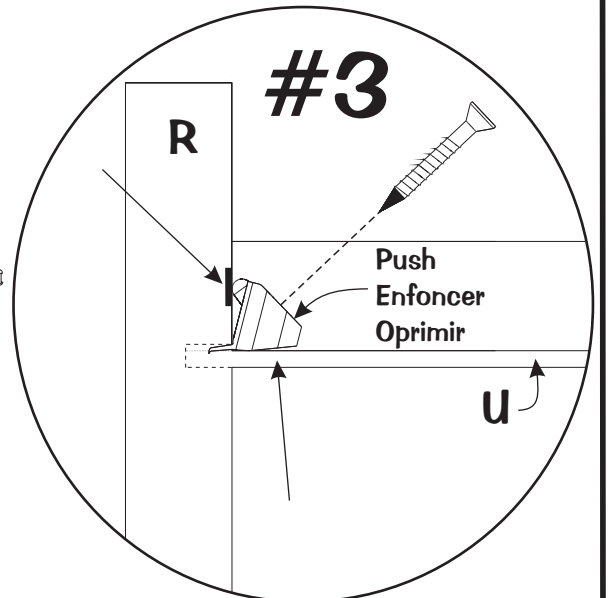
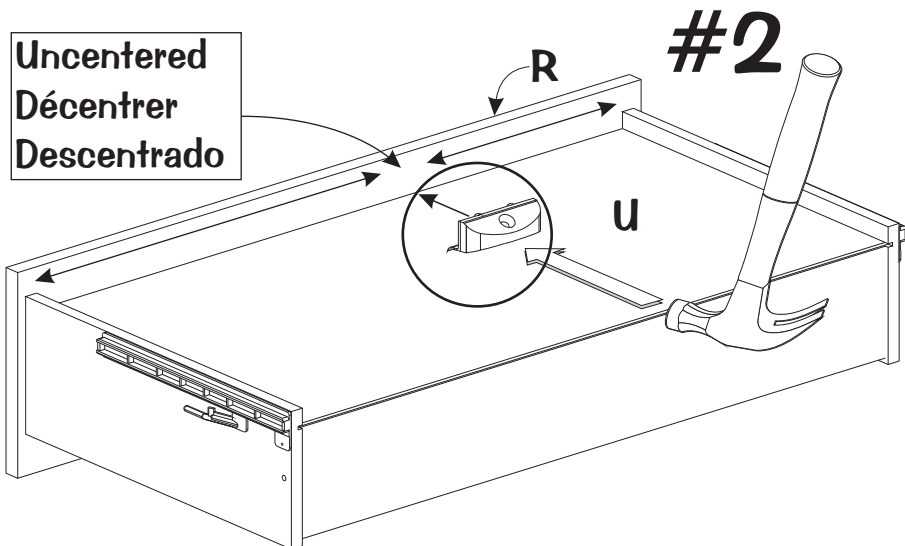
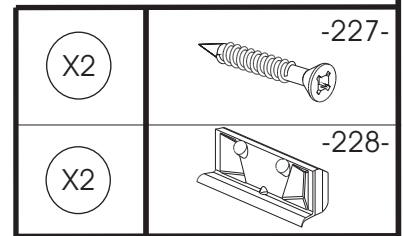

21

Lift up both side to take out the drawer
Lever de chaques côtés pour enlever le tiroir.
Levantarse a cada lado para quitar El cajón

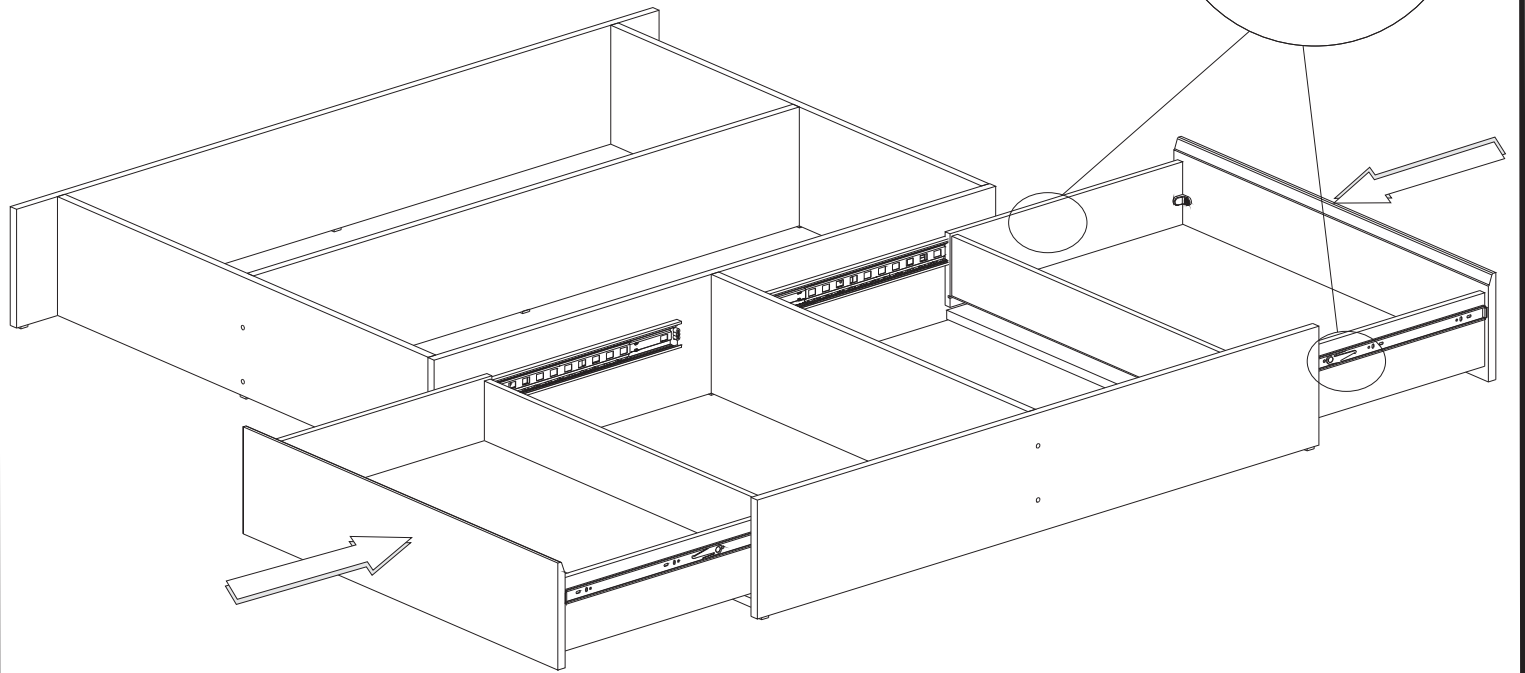

22

HEAD
ARRIÈRE
DETRÁS

X10

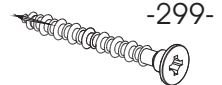

-299-

X2

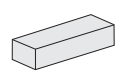

-Z-01-

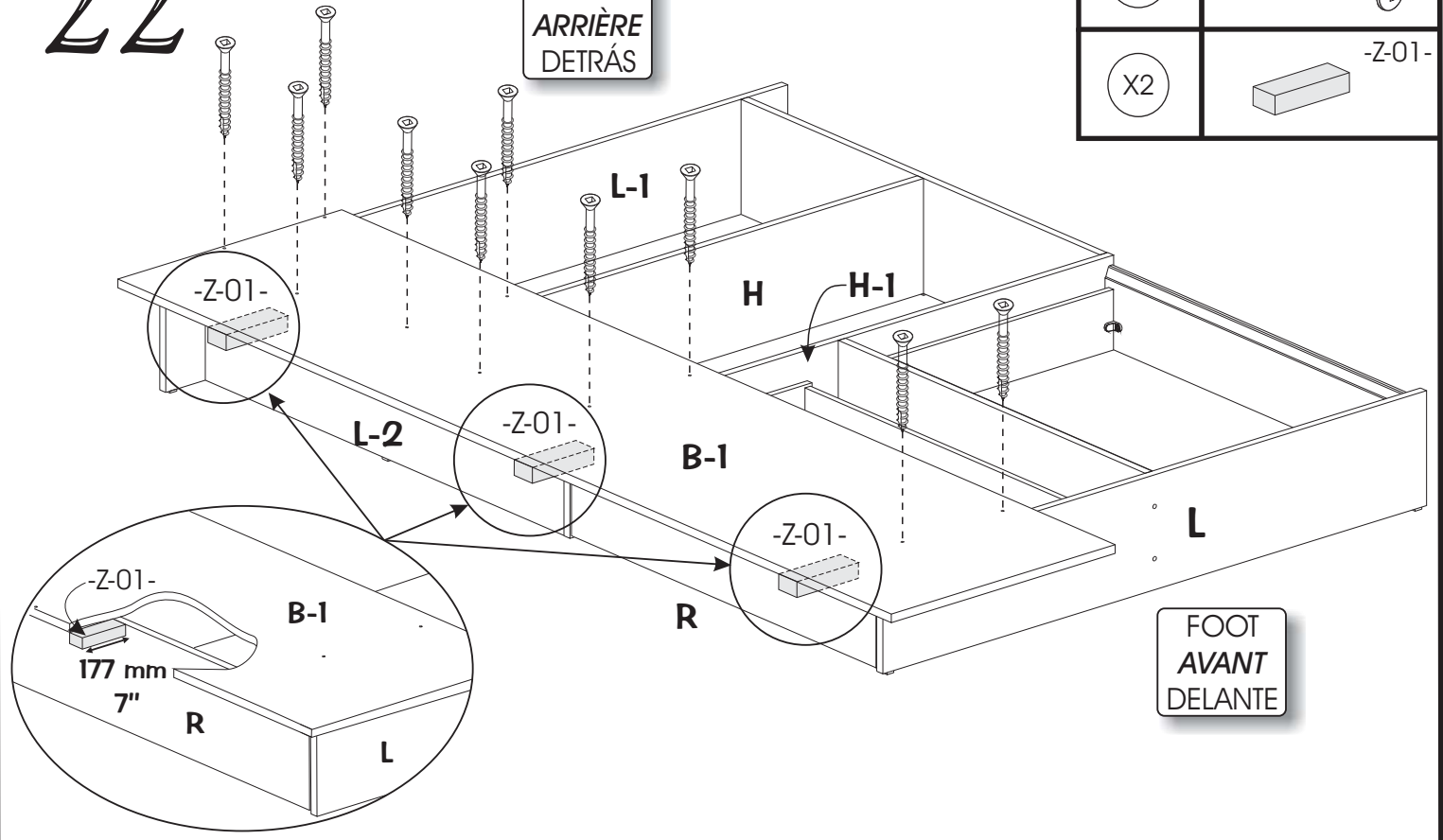

FOOT
AVANT
DELANTE

23

X18

-299-

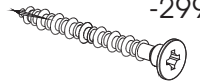

HEAD
ARRIÈRE
DETRÁS

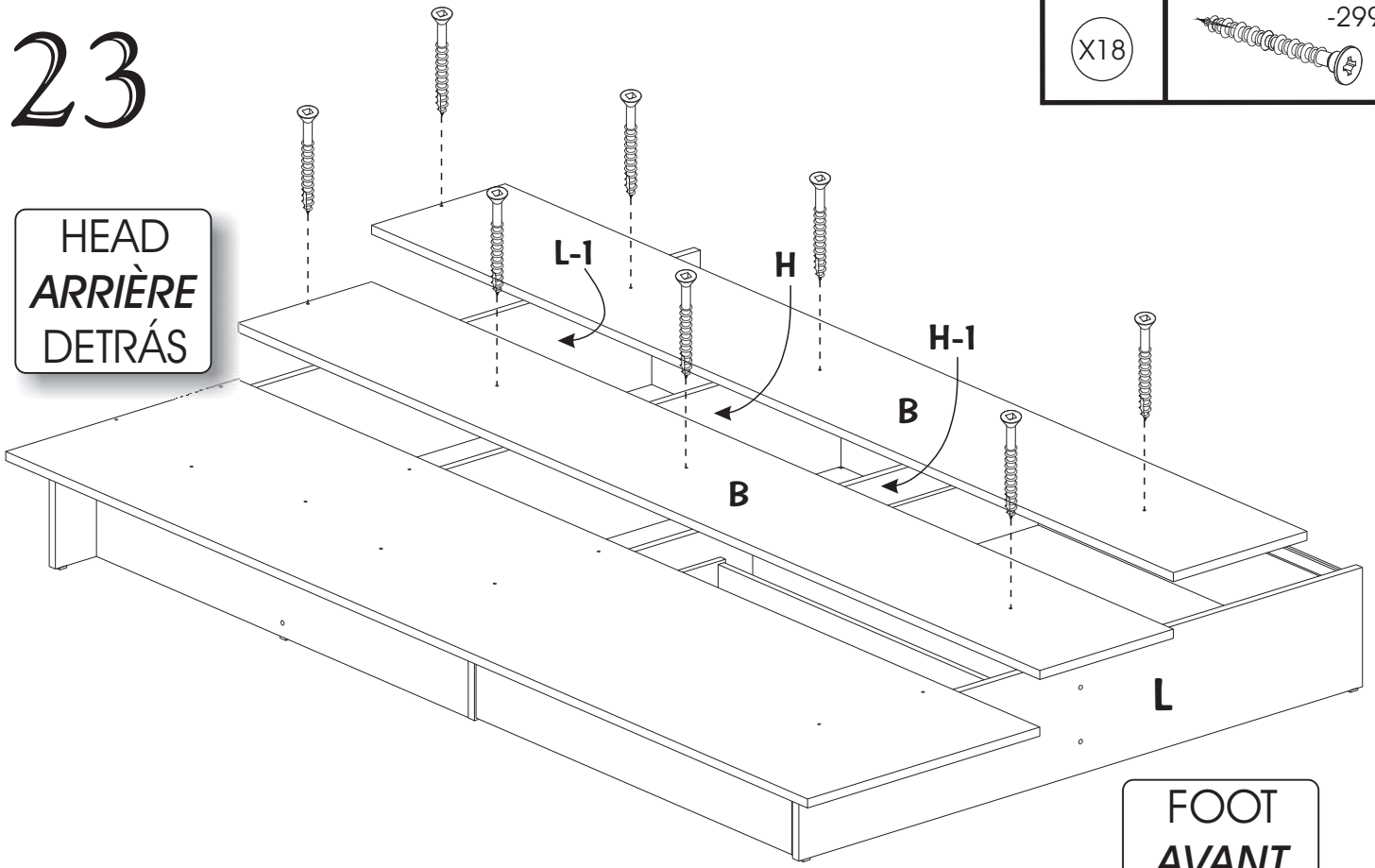

FOOT
AVANT
DELANTE

HEAD
ARRIÈRE
DETRÁS

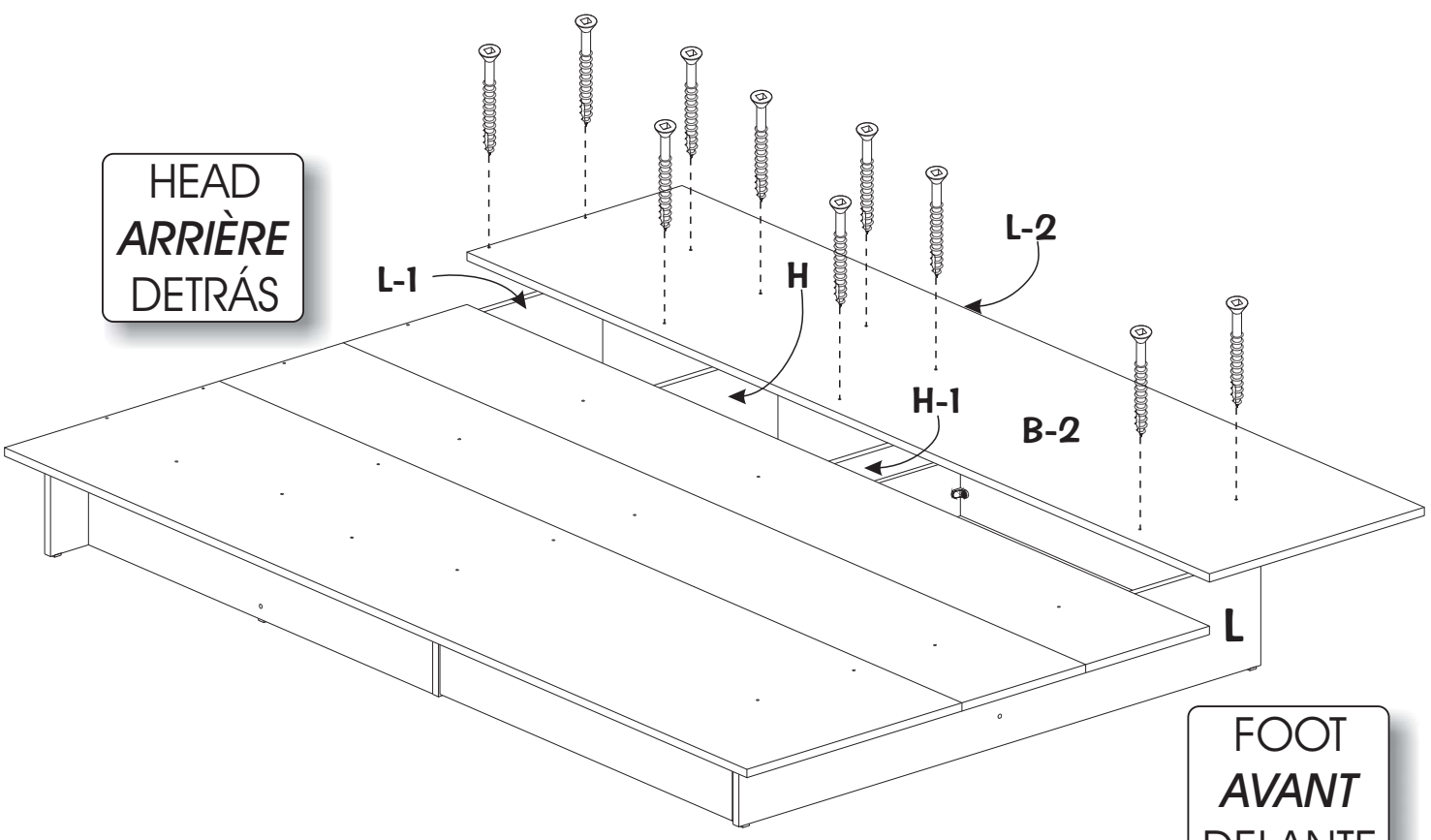

FOOT
AVANT
DELANTE

24

X16



-169-

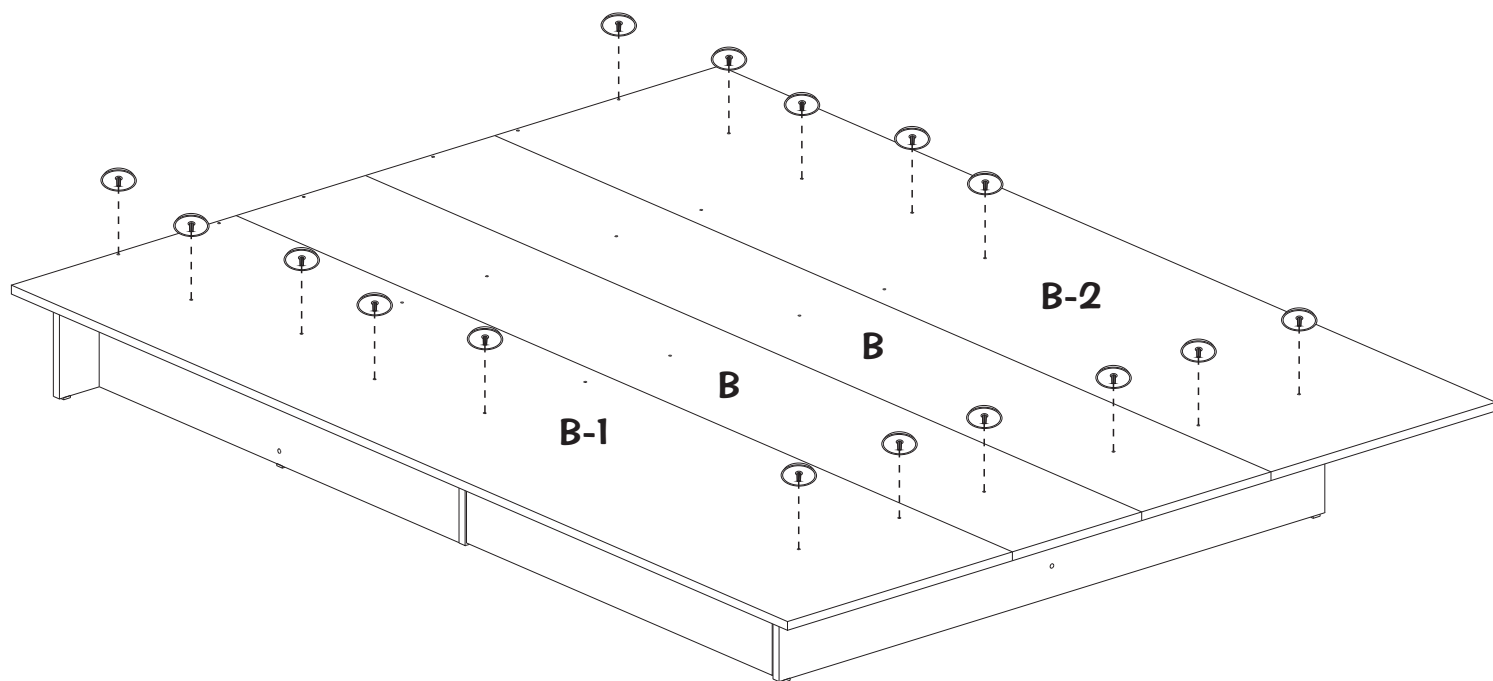

25

X12



-99-

X3

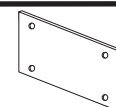

-335-

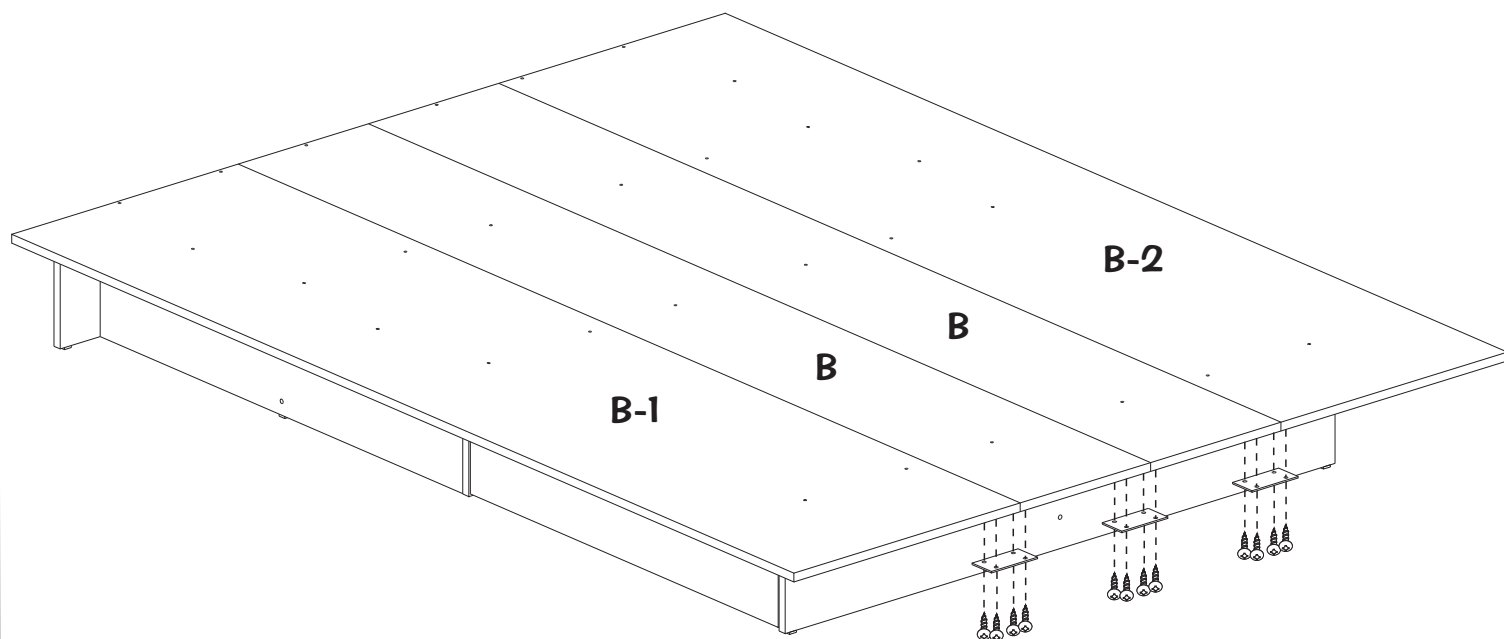

MAINTENANCE TIPS / CONSEILS D'ENTRETIEN / CONSEJOS DE MANUTENIMIENTO

- Never let liquids or damp cloths sit on this furniture.
- *Ne jamais laisser de liquide ou linge humide sur le meuble.*
- Nunca deje un líquido o un trapo húmedo sobre el mueble.



- Never use ammonia-based cleaning products, as they will damage the finish.
- *Ne jamais utiliser de nettoyeur à base d'ammoniaque, cela va endommager le fini.*
- Nunca utilice un producto de limpieza a base de amoníaco, esto dañará el acabado.



- To avoid dulling of the finish, do not place furniture in direct sunlight.
- *Ne pas placer le meuble directement au soleil pour prévenir le ternissement.*
- No exponga el mueble directamente al sol para prevenir empañamiento.

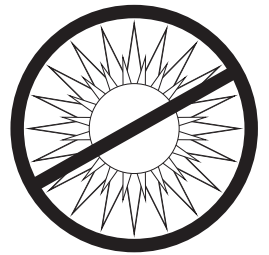

- Do not put plastic or rubber rings under appliances.
Use cloth or felt protectors.
- *Évitez de déposer des appareils avec des rondelles de plastique ou de caoutchouc.
Utilisez un protecteur en tissu ou en feutre.*
- Evite apoyar aparatos con redondeles de plástico o de goma.
Utilizar un protector de tela o de fieltro.



- To clean, use a soft or slightly damp cloth, then wipe with a clean, dry cloth.
- *Pour nettoyer, utilisez un linge doux ou légèrement humecté.
Essuyez par la suite avec un linge propre et sec.*
- Para limpiar, utilice un trapo suave o ligeramente humedecido.
Seque luego con un trapo limpio y seco.



5 YEAR LIMITED WARRANTY

1. South Shore Industries Ltd. provides the original buyer with a warranty covering «defects» on furniture parts and workmanship for a period of 5 years from the date of purchase.
2. The word «defect» as used in this warranty is defined as any imperfection that may impair the use of the product for which it was intended.
3. This warranty is strictly limited to the repair or replacement of defective component parts, and excludes all other direct or indirect charges and expenses up to the limit permitted by law in your state/province.
4. In the case of a discontinued part or product, we promise to reimburse the value of that part or product.
5. If a replacement part is unavailable, South Shore Industries Ltd.'s liability to the buyer will not exceed the production cost of the part in question.
6. This warranty only applies under conditions of normal domestic use. It does not cover defects resulting from commercial use, intentional damage, negligence, abuse, product modification, accidents, exposure to the elements, or maintenance that does not comply with the guidelines on this booklet.
7. This warranty is only valid on condition that South Shore Industries Ltd can reserve the right to verify the basis of any request, and also to see the original buyer proof of purchase.
8. This warranty is only valid for purchases made at an authorized retailer for South Shore Industries Ltd. in Canada or the U.S.
9. This warranty defines the limits of South Shore Industries Ltd.'s liability, and entitles the original buyer to specific rights. Any warranty defined by law in your state/province is limited to a period of 5 years. If the law in your state/province prohibits this restriction, then it does not apply.
10. South Shore Industries Ltd does not give reimbursements for defective furniture, but will replace it with an item of equivalent value.

GARANTIE LIMITÉE DE 5 ANS

1. Les Industries de la Rive Sud Ltée garantissent à l'acheteur original, pour une période de 5 ans depuis sa date d'achat, toutes les pièces composantes d'un meuble contre les «défauts» de matériaux et de main-d'œuvre.
2. Le mot «défaut» utilisé dans cette garantie se définit comme une imperfection pouvant altérer l'utilité pour laquelle le produit est destiné.
3. Cette garantie se limite strictement à la réparation ou au remplacement des pièces composantes défectueuses. Cette garantie exclut tout autre frais directs ou indirects et ce, jusqu'à la limite permise par la législation en vigueur dans votre lieu de résidence.
4. Dans le cas d'une réclamation concernant un produit ou une pièce discontinuée, Les Industries de la Rive Sud Ltée s'engagent à rembourser la valeur du produit ou la pièce en question.
5. À défaut de pouvoir fournir la pièce de remplacement, la responsabilité des Industries de la Rive Sud Ltée ne peut excéder la valeur équivalente au coût de production de la pièce en litige.
6. Cette garantie s'applique sous des conditions d'usage domestique normal et ne couvre pas les défauts pouvant résulter d'un usage commercial, de dommages intentionnels de la négligence, de l'usage abusif, de modifications personnelles, d'un accident, de l'exposition aux éléments et de l'entretien ne respectant pas les conseils décrits dans ce livret.
7. Comme condition pour fournir une pièce de remplacement, les Industries de la Rive Sud Ltée se réservent le droit de vérifier le fondement de la requête, de même que d'exiger la preuve d'achat de l'acheteur original.
8. Cette garantie n'est valide que si et seulement si l'achat a été effectué chez un marchand autorisé par les Industries de la Rive Sud Ltée au Canada et aux États-Unis.
9. Cette garantie définit les limites de la responsabilité des Industries de la Rive Sud Ltée et donne à l'acheteur original des droits spécifiques. Toute garantie législative prévalant dans votre lieu de résidence est limitée à une période de 5 ans. Si cette restriction n'est pas permise par la législation de votre lieu de résidence, elle ne s'applique pas.
10. Les Industries de la Rive Sud Ltée ne rembourseront pas les meubles défectueux, mais vous feront parvenir un item.

GARANTIA LIMITADA DE 5 AÑOS

1. Las Industrias de la Rive Sud Ltée garantizan al comprador original, por un período de 5 años a partir de la fecha de compra, todas las piezas que componen el mueble contra los «defectos» de material y mano de obra.
2. La palabra «defecto» utilizada en esta garantía se define como toda imperfección que pueda alterar la utilidad para la cual se destina el producto.
3. Esta garantía se limita estrictamente a la reparación o reemplazo de las piezas que tengan componentes defectuosos. Esta garantía no incluye cualquier gasto directo o indirecto hasta el límite permitido por la legislación vigente en su lugar de residencia.
4. En el caso de una reclamación referente a un producto o pieza discontinuada, Les Industrias de la Rive Sud Ltée se compromete a reembolsar el valor del producto o pieza en cuestión.
5. A falta de poder suministrar la pieza de repuesto, la responsabilidad de Industrias de la Rive Sud Ltée no puede exceder el valor equivalente al costo de producción de la pieza en litigio.
6. Esta garantía se aplica bajo las condiciones de uso doméstico normal y no cubre los defectos que puedan resultar de un uso comercial, daños intencionales, negligencia, uso abusivo, modificaciones personales, un accidente, exposición a los elementos y mantenimiento sin respetar los consejos que se describen en este cuaderno.
7. Como condición para suministrar una pieza de repuesto, las Industrias de la Rive Sud Ltée se reservan el derecho de verificar el fundamento de la solicitud, así como de exigir la prueba de compra del comprador original.
8. Esta garantía es válida solamente si la compra se efectuó en un comerciante autorizado por las Industrias de la Rive Sud Ltée en Canadá y los Estados Unidos de América.
9. Esta garantía define los límites de la responsabilidad de las Industrias de la Rive Sud Ltée y otorga el comprador original los derechos específicos. Cualquier garantía legislativa que prevalece en su lugar de residencia está limitada a un período de 5 años. Si esta restricción no está permitida por la legislación de su lugar de residencia, ésta no se aplica.
10. Las Industrias de la Rive Sud Ltée no reembolsarán los muebles defectuosos, pero les enviarán un artículo.

CUSTOMERS SERVICE / SERVICE À LA CLIENTÈLE / SERVICIO A CLIENTELE

CANADA / USA

1-800-290-0465 

MEXICO

001-800-514-5320 

toll free number / lada sin costo 



6168, Rue Principale, C.P. 190
SAINTE-CROIX, QUÉBEC
CANADA, G0S 2H0



FAX: 1-877-586-5339

INTERNATIONAL

418-926-2691 



E-MAIL: service@southshore.ca
WEB: www.southshore.ca