



## Powered Water Filtration System **Set Up** Instructions

### **Quick Start**

- Insert filter before using
- Flush system one full cycle before drinking
- Enjoy delicious, Aquasana filtered water!

Please read entire set up instructions before using.

### **We're here to help!**

Our experts can guide you through your new system questions or concerns. Contact us directly at **866.662.6885** or **[support@aquasana.com](mailto:support@aquasana.com)**.

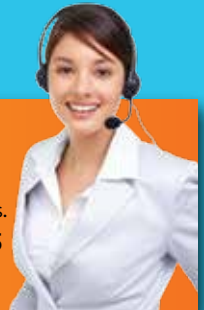



## Contents

AQ-PWFS-RB1, AQ-PWFS-RB2, AQ-PWFS-RB1W, AQ-PC, AQ-PC-BK

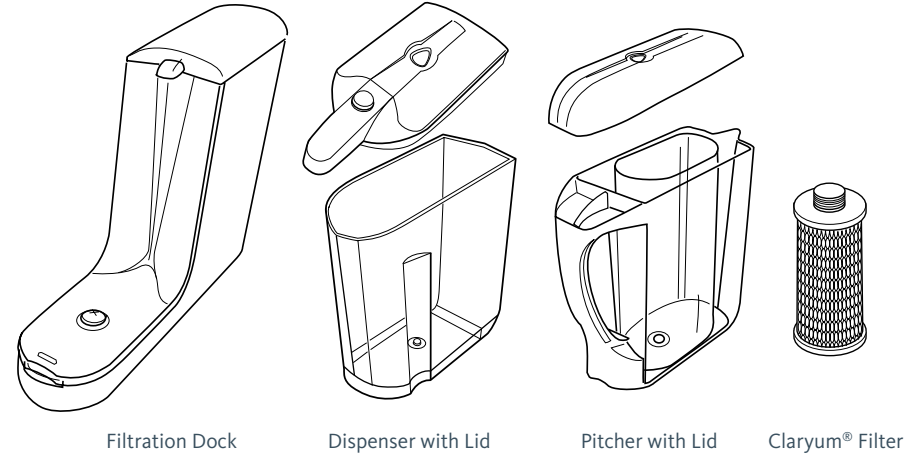

AQ-PWFS-P-W, AQ-PWFS-P-B

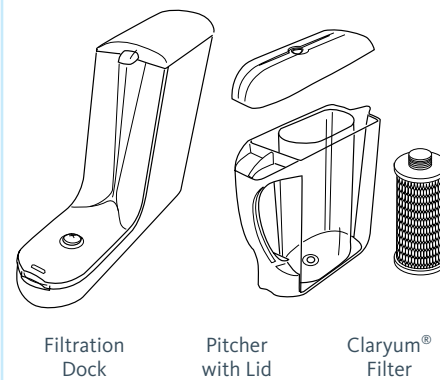

AQ-PWFS-D-W, AQ-PWFS-D-B

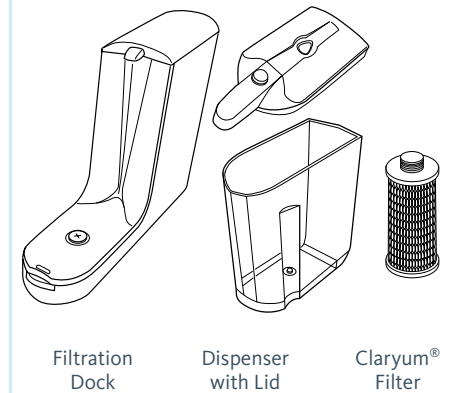

Welcome to the Aquasana experience. You are about to enjoy clean, healthy water and the peace of mind that comes from knowing award-winning filter technology is working for you.

### System Set-up

Please read entire installation guide before using the filter system and ensure all parts listed are present. If any part is missing or damaged, do not attempt to operate the filter. Please contact Customer Service for replacement parts at (866) 662-6885.

Not all purchases include both pitcher and dispenser. Additional pitchers and dispensers are optional. Extra pitchers and dispensers can be purchased at [aquasana.com](http://aquasana.com).

# Easy to install

## Prepare the filtration dock

- Unpack and unwrap contents of box and remove plastic wrapping from smart filter cartridge.
- Install smart filter.

With filtration dock facing forward, use grooves on the left hand side of the top cover to slide the top cover to the right until it lifts up and off.

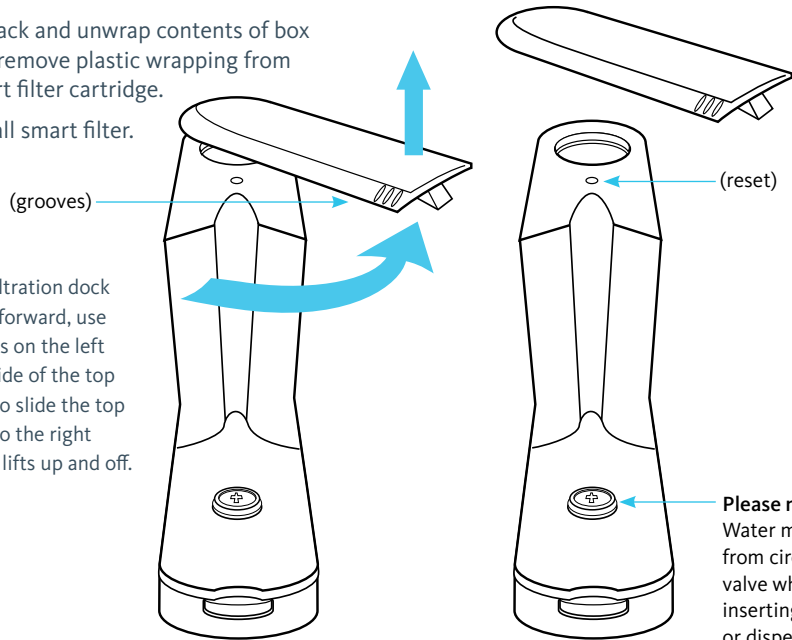

**IMPORTANT**  
Flush system one cycle before drinking

**Please note:** Water may leak from circular valve when inserting pitcher or dispenser onto dock.

**Indicator Light Key:** Lights will be on only while the system is running.

<b>SOLID BLUE</b> FILTER IS AT OPTIMAL PERFORMANCE	<b>SOLID RED</b> FILTER IS AT 90% CAPACITY	<b>BLINKING RED</b> FILTER REACHED 100% CAPACITY CHANGE FILTER

Drop the filter cartridge into the opening on the dock as shown (male end up). Next, place the top cover back on the dock. Pressing down firmly, rotate the top cover back to the left until it is fully closed and locked in.

Once filter is installed, plug the filtration dock into an electrical outlet.

## Pitcher

- **New filters must be flushed (1 full pitcher) before drinking.**  
**Note:** Filtering may take up to 2 minutes to begin on the initial run.
- Place lid on pitcher.
- Fill center reservoir with **cold water** through drop-shaped opening.
- Place pitcher with lid onto the filtration dock until fully locked in.

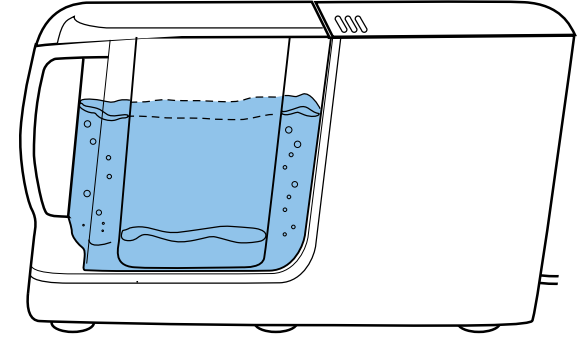
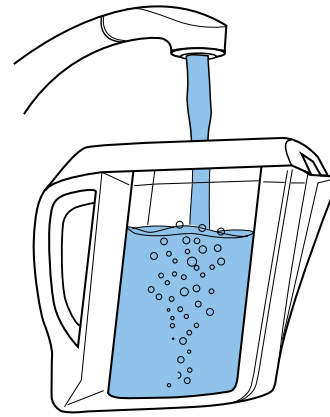

Once pitcher is attached to the filtration dock, it will automatically begin filtering. There will be a 5-10 second delay before the outer reservoir starts to fill.

The system will run until the center reservoir is completely empty. **Do not** refill center reservoir with unfiltered water if there is still filtered water left in the outer reservoir. System will overflow.

**Please wait for the front light to turn off before removing the pitcher from the dock.**

**SYSTEM WILL NOT RUN WITHOUT WATER**

**SYSTEM WILL NOT RUN WITHOUT LID SECURED ON PITCHER OR DISPENSER**

## Dispenser

- **New filters must be flushed (1 full dispenser) before drinking.**  
**Note:** Filtering may take up to 2 minutes to begin on the initial run.
- Place lid on dispenser.
- Fill dispenser with **cold water** through drop-shaped opening.
- Attach dispenser with lid onto the filtration dock until fully locked in.

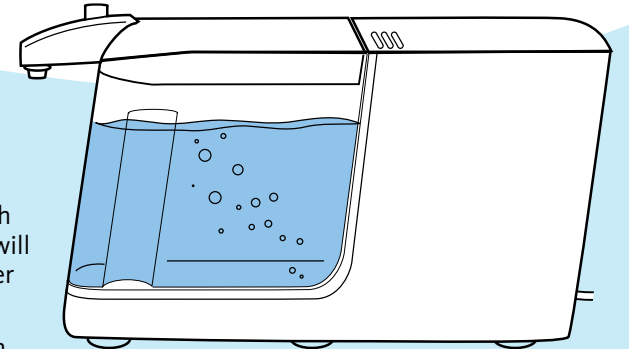
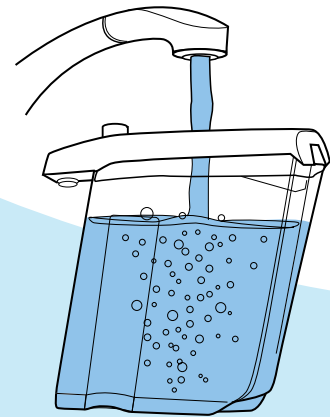

To dispense filtered water, push button on reservoir lid. There will be a 5-10 second delay for water to filter through.

Please wait for system to finish filtering before removing the dispenser from the dock.

Once dispenser is removed there may be residual water left on the dock; this is normal.

## Use and Care Guide

To clean your filter unit, wipe down the exterior with a damp cloth.

Both the pitcher body and dispenser body are dishwasher safe. The lids are NOT dishwasher safe and should be hand washed only. DO NOT use the heat cycle of the dishwasher for drying your pitcher body and dispenser body.

### Replacing your Claryum® smart filter

When the blue light changes to a solid red light, your filter has reached a 90% capacity.

When the solid red light starts blinking your filter has reached a 100% capacity and needs to be replaced.

Your old filter can be removed and discarded.

Failure to replace the filter when needed can cause damage to your system.

Press reset button when you replace your smart filter (see replacement cartridge instructions).

THE INDICATOR  
LIGHTS WILL BE ON  
ONLY WHILE  
THE SYSTEM IS  
RUNNING

## Troubleshooting Guide

### What should I do if my system won't run?

- Make sure the system is plugged into a power source.
- Ensure that the pitcher or dispenser is fully attached to the filtration dock — remove pitcher/dispenser and place it back onto the filtration dock.
- Make sure the center reservoir (pitcher) or dispenser contains water. System will not run without water.
- Dry up any excess water that may be on the base of the filtration dock.
- Make sure lid is attached to pitcher or dispenser. System will not run without lid being attached to pitcher or dispenser correctly.

FLUSH FILTER CARTRIDGE AND SYSTEM ONE FULL CYCLE BEFORE CONSUMING. SYSTEM MAY TAKE UP TO TWO MINUTES DURING THE INITIAL FLUSHING PERIOD TO START FILTERING WATER THROUGH THE NEW FILTER CARTRIDGE.

### What if water is leaking from bottom of pitcher when attached to the base?

- Ensure that the pitcher or dispenser is fully attached to the filtration dock — remove pitcher/dispenser and place it back onto the filtration dock.

### What should I do if my system is leaking between the top cover and filtration dock?

- Remove top cover from filtration dock.  
(Refer to “Easy to Install” section on how to remove the cover.)
- Ensure that the black rubber “o-ring” is in place on the bottom connection point of the lid.
- Ensure the cartridge is installed correctly. (Refer to “Easy to Install” section.)

### My water is cloudy.

- Cloudy water is just microscopic air bubbles, and should dissipate within a few minutes of filling outer reservoir.
- If cartridge was flushed through 1 full cycle and you continue to see cloudiness, this is normal for the first few days of use on new cartridge installations.

### The circular valve at the base of the dock leaks when I put the pitcher or dispenser on the dock.

- Ensure you insert the pitcher or dispenser squarely on top of the circular valve to avoid depressing the valve plunger that releases water.
- Small amounts of water on the base will not disrupt the filter system.

## Precautions:

- Do not operate without the filter cartridge installed.
- Filter is only to be used with cold water.
- Children and persons whose physical, sensory or mental capabilities or lack of experience and knowledge using the system safely without instruction should have supervision while using the filtration system.
- Do not use with water that is microbiologically unsafe or of unknown quality without adequate disinfection before or after the system.
- Systems certified for cyst reduction may be used on disinfected waters that may contain filterable cysts.

## Product Specs:

### Pitcher (Complete System):

Height: 11 5/8”

Length: 17 1/2”

Width: 4 1/2”

Volume: 8 cups (1/2 Gallon)

Operating temp range:  
40-90° F (4.44-32.2° C)

Rated flow rate:  
0.5 gpm (1.8 lpm)

Capacity of filter:  
320 gallons (1,211 l)

Min-Max Working Pressure:  
20-70 psi (137-482 kPa)

Voltage:  
100-240

### Dispenser (Complete System):

Height: 11 5/8”

Length: 20 1/4”

Width: 4 1/2”

Volume: 16 cups (1 Gallon)

Operating temp range:  
40-90° F (4.44-32.2° C)

Rated flow rate:  
0.5 gpm (1.8 lpm)

Capacity of filter:  
320 gallons (1,211 l)

Min-Max Working Pressure:  
20-70 psi (137-482 kPa)

Voltage:  
100-240

### Pitcher:

Height: 9 7/8”

Length: 11 1/4”

Width: 4 1/2”

### Dispenser:

Height: 9 7/8”

Length: 12”

Width: 4 1/2”

### Filtration Dock:

Height: 11 5/8”

Length: 16 1/4”

Width: 4 1/2”

## Warranty

A 1-year warranty is included, which covers defects in materials and workmanship. This filter system is designed and tested for use with genuine Aquasana parts, including replacement filters and all hardware. Use of parts from other manufacturers may result in loss of contaminant reduction performance, system damage or failure. Use of parts from other manufacturers will also void your warranty. Please visit your retailer or [www.aquasana.com](http://www.aquasana.com) for all replacement parts.



**aquasana**<sup>®</sup>  
*Live Healthy*<sup>™</sup>

**Aquasana, Inc.**

6310 Midway Road  
Haltom City, Texas 76117  
866.662.6885 USA  
877.332.7873 Canada  
[www.aquasana.com](http://www.aquasana.com)

**For exclusive deals**

 [facebook.com/aquasana](https://facebook.com/aquasana)  
 [twitter.com/aquasana](https://twitter.com/aquasana)