

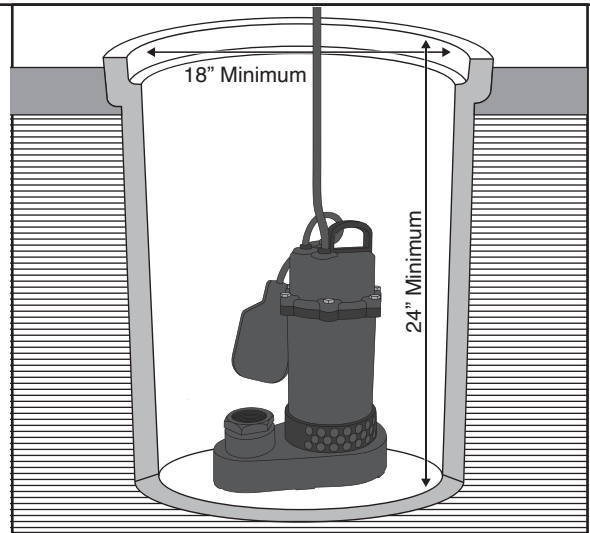

Submersible Sump Pump

Quick Reference Guide

See instruction manual for complete instructional details.



1. Ensure basin is clear of all debris and place pump on hard level surface (not dirt or gravel). 18" x 24" minimum basin size required.

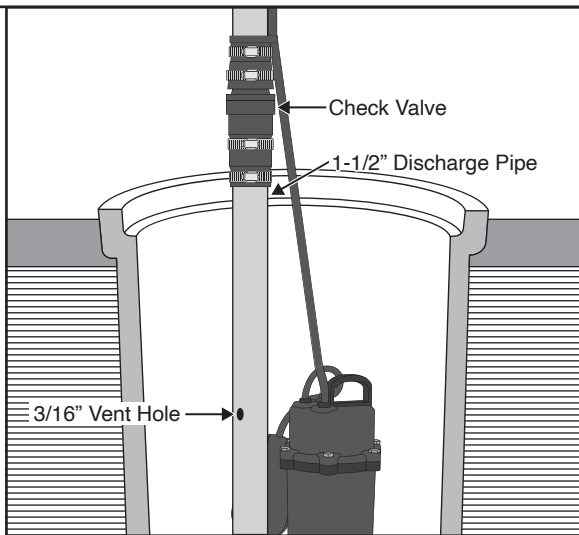

2. Measure, cut and install discharge fittings, check valve, and piping. Drill a 3/16" hole in the discharge pipe, level with the top of the pump.

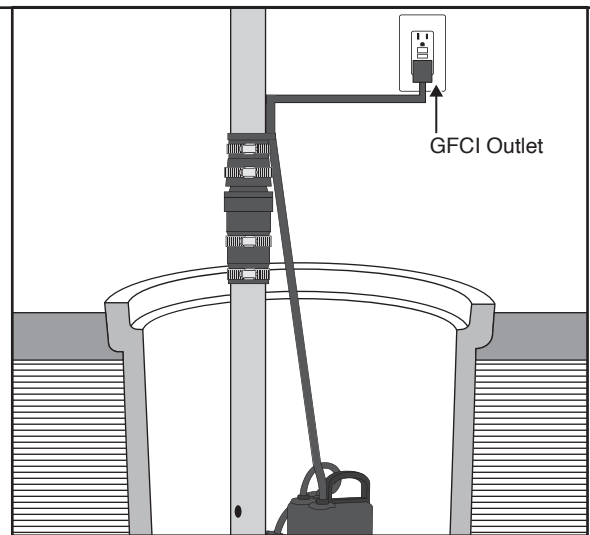

3. Plug Pump in to GFCI outlet on dedicated circuit with 15 amp breaker

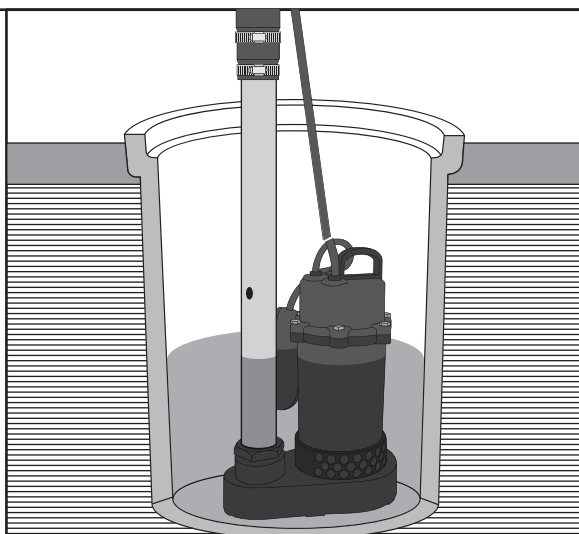

4. Test operation by adding water until float rises, pump turns on, and the water level drops. Float will lower with the water level and turn the pump off.

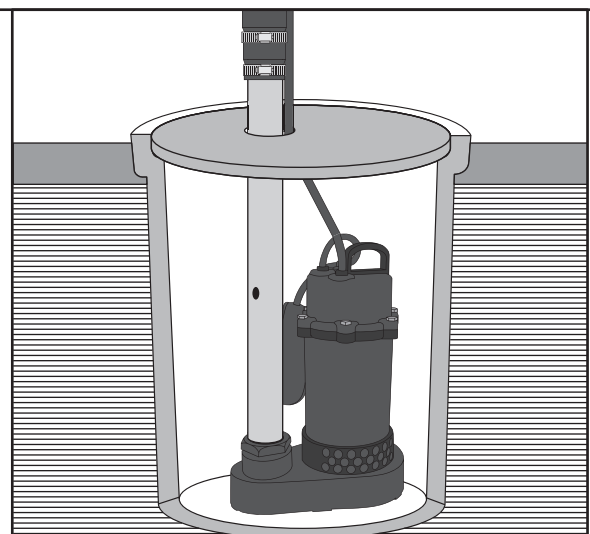

5. Install optional basin cover.