

# ROME

## Assembly instruction Instrucciones de instalación

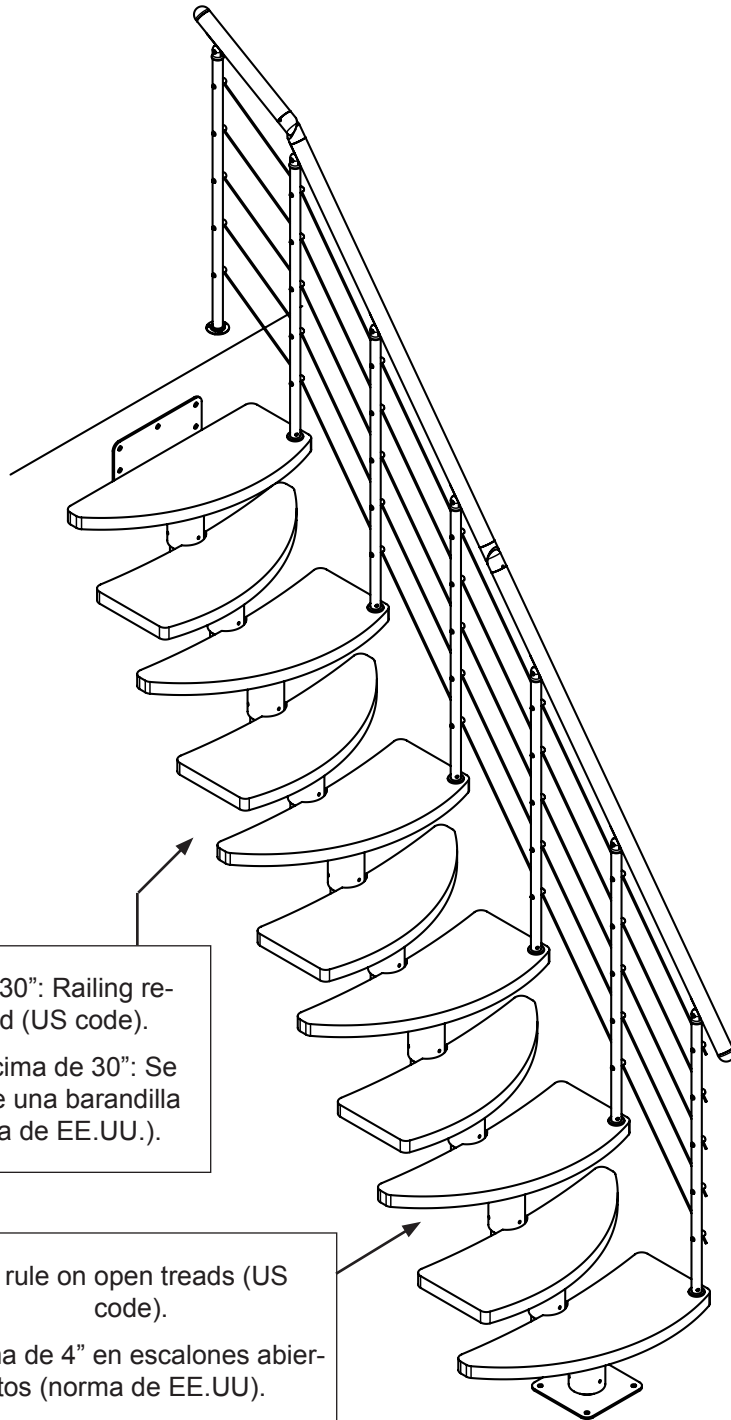

Above 30": Railing required (US code).

Por encima de 30": Se requiere una barandilla (norma de EE.UU.).

4" rule on open treads (US code).

Norma de 4" en escalones abiertos (norma de EE.UU.).

Mounting videos:  
Videos de montaje:  
[www.dolleusa.com](http://www.dolleusa.com)

Review these instructions completely before beginning installation.  
Questions - call customer service 855-DOLLE US or 763-746-7830 - Monday - Friday 8:00-5:00 central. Metric tools required.

Revise estas instrucciones en su totalidad antes de iniciar la instalación.  
Si tiene alguna pregunta, llame al servicio al cliente al 855-DOLLE desde los EE.UU. o al 763-746-7830 de lunes a viernes de 8:00 a 5:00, hora central de los EE.UU. Se necesitan herramientas métricas.











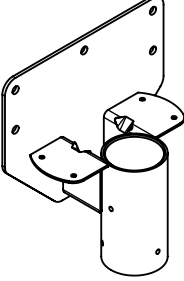
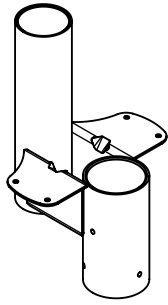
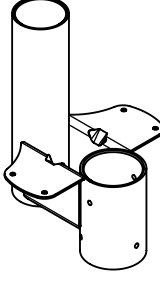
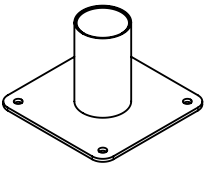
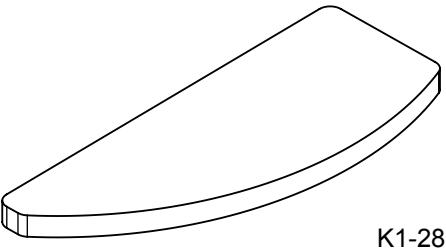
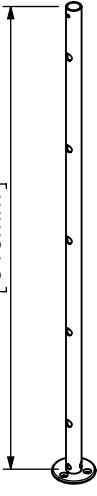
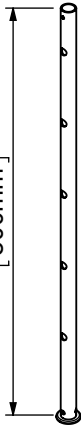



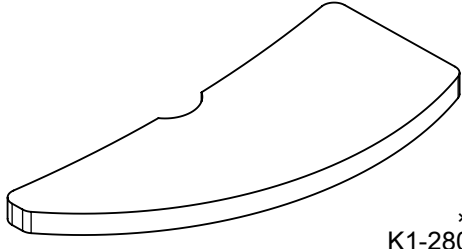



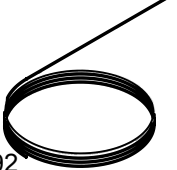
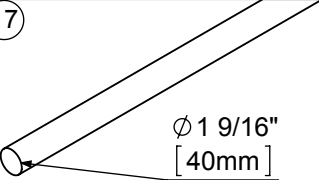







Local building codes vary. Please consult with your local officials for specific requirements.

Las normas de construcción locales pueden variar. Póngase en contacto con los técnicos locales para conocer los requisitos locales.

## Part list • Parte de la lista

**Components & Number of Each Component**  
Please check that all items are included before assembly

**Componentes y Número de cada componente**  
Verifique que todos los componentes estén incluidos antes de la entrega

<p>①</p>  <p>× 1 K2-29240</p>	<p>②</p>  <p>× 9 K2-29230</p>	<p>③</p>  <p>× 1 K2-29270</p>	<p>④</p>  <p>× 1 K2-29250</p>				
<p>⑤</p>  <p>× 1 K1-28010</p>	<p>⑦</p>  <p>35 13/16" [910mm]</p> <p>× 1 K2-29281</p>	<p>⑧</p>  <p>31 1/2" [800mm]</p> <p>× 6 K2-29280</p>	<p>⑨</p>  <p>× 7 K1-29204</p>	<p>⑩</p>  <p>× 7 K1-12207</p>	<p>⑪</p>  <p>× 2 K2-01020</p>		
<p>⑥</p>  <p>× 10 K1-28020</p>	<p>⑫</p>  <p>× 6 K2-01010</p>	<p>⑬</p>  <p>× 1 K1-01620</p>	<p>⑭</p>  <p>× 10 K2-04200</p>	<p>⑮</p>  <p>× 35 K1-04041</p>	<p>⑯</p>  <p>59' [18 m] K1-23292</p>		
<p>⑰</p>  <p>Ø 1 9/16" [40mm]</p> <p>× 3 K1-29915</p>	<p>⑳</p>  <p>× 1 K3-10520 Torx 20</p>	<p>㉑</p>  <p>× 1 K3-10525 Torx 25</p>					
<p>④⑩</p>  <p>× 9 K3-08004 Ø10×60mm</p>	<p>④⑪</p>  <p>× 9 K3-04028 Ø8mm</p>	<p>④⑫</p>  <p>× 9 K3-06015 Ø8×70mm</p>	<p>④⑬</p>  <p>× 55 K3-05003 M8×6mm</p>	<p>④⑭</p>  <p>× 44 K3-06030 Ø6×30mm</p>	<p>④⑮</p>  <p>× 3 K3-08002 Ø8×40mm</p>	<p>④⑯</p>  <p>× 3 K3-06022 Ø5×35mm</p>	<p>④⑰</p>  <p>× 7 K3-05060 M6×8mm</p>
<p>④⑱</p>  <p>× 7 K3-01002 M5×18mm</p>	<p>④⑲</p>  <p>× 7 K3-03020 M5mm</p>	<p>④⑳</p>  <p>× 14 K3-06018 Ø4×25mm</p>	<p>④㉑</p>  <p>× 6 K3-07008 M10×70mm</p>	<p>④㉒</p>  <p>× 6 K3-04030 Ø10mm</p>	<p>④㉓</p>  <p>× 6 K3-03010 M10mm</p>	<p>④㉔</p>  <p>× 35 K1-04040 M6×18mm</p>	<p>④㉕</p>  <p>× 14 K3-06064 Ø4×25mm</p>

**IMPORTANT:** DO NOT USE PARTS OTHER THAN THOSE INCLUDED WITH THE PRODUCT. REPLACEMENT PARTS PURCHASED LOCALLY MUST BE METRIC.

IN CASE PARTS HAVE BEEN LOST OR DAMAGED CONTACT DOLLE USA INC. FOR REPLACEMENT.

**IMPORTANTE:** NO UTILICE PIEZAS DIFERENTES DE LAS SUMINISTRADAS CON EL PRODUCTO. LAS PIEZAS DE RECAMBIO ADQUIRIDAS POR SEPARADO DEBEN SER MÉTRICAS. EN CASO DE PÉRDIDA DE PIEZAS O DE PIEZAS DAÑADAS, PÓNGASE EN CONTACTO CON DOLLE USA INC.

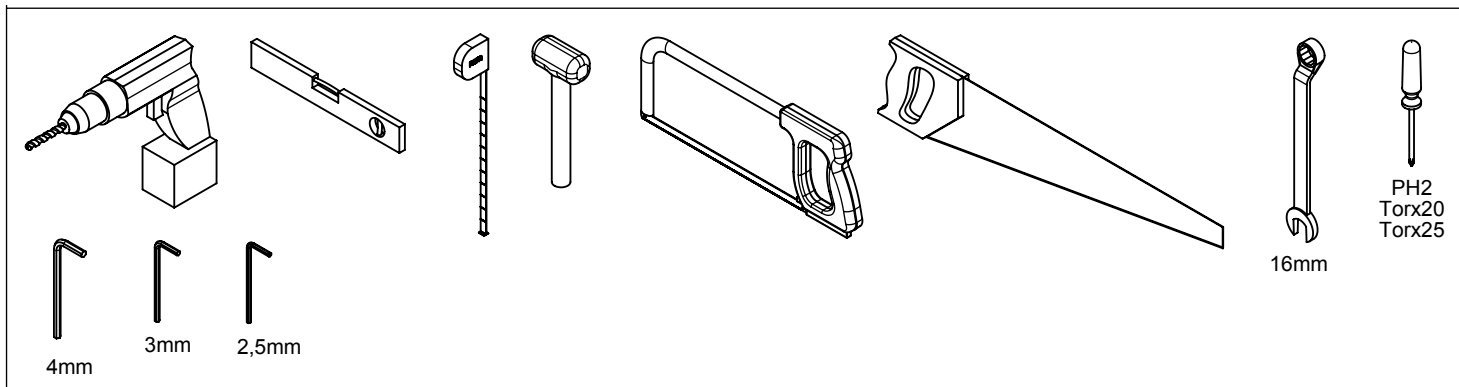

TOOLS REQUIRED - NOT SUPPLIED  
HERRAMIENTAS NECESARIAS - NO SUMINISTRADAS

## Preparation (Figure A)

- Choose the required floor plan – see page 5.
- Alternate the wide dimensions on successive treads of straight runs and less than 20° angles.
- If the angle of two successive steps is greater than 20°, the wider dimension of the treads are to face outward – see Figure A2 and A3, page 5.

## Before installation

### IMPORTANT

Before starting installation, calculate the exact rise height of each step of the staircase. This is done by measuring the distance from the lower floor to the upstairs floor measuring vertically along the wall and then dividing by the number of rises. The number of rises is the same as the number stair treads plus 1. The plus 1 is to consider distance of the last step of the staircase to the upstairs floor.

**S** = (page 5)

Example: Top edge of floor to top edge of next floor: 102", 12 rises (11 steps + 1).  
 102" divided by 12 = 8 1/2". This is the rise height per step.

The opening in the ceiling should not be less than 51 1/4" for straight flights of steps.

This is to ensure that walking up the steps is a comfortable experience.

Recommended rise height: 7 5/16" to 8 1/16"

Maximum rise height: 7 5/16" to 8 1/16"

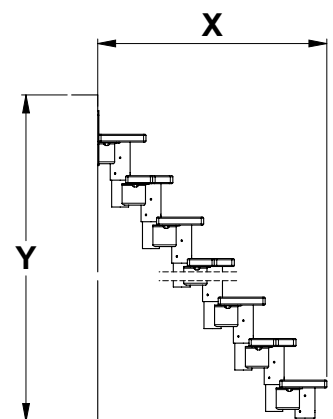

## Installation (Figure 1 - 14)

NB! The staircase should be assembled from the TOP DOWNWARDS.

- Start assembling the staircase – begin with figure (1).
- REMEMBER – Use the calculated rise height for installing each tread
- REMEMBER – Use a support to stabilize the staircase once the first four treads have been installed – see Figure 3.

Figure (4): Assemble the last two treads separately BEFORE installing them to the staircase – DO NOT tighten.  
Next, insert in the last two treads and adjust the calculated rise height and tighten.

Figure (7): Installing the treads:  
Turn the wide side of the top tread towards the handrail. Next, install the treads working downwards, alternating right and left.

**Notice!** It is easier to pre-drill the treads for the railing prior to installation.  
Use the enclosed template - at page 11.

Place the treads in the middle of the support, check distance (X) – see Figure (7) and distance (Y) – see Figure (8).

**Notice!** If the angle of two successive treads is greater than 20°, the treads are to be turned the same way with wide dimension outward– see Figure A2 and A3 at page 5.

Figure (9–13), (14):  
Installing the handrail:  
Start at the top tread and affix the balusters to every second tread.  
Attach the upstairs landing baluster to the floor, then fit the handrail on to the installed baluster. To complete the railing install wire fill on to the balusters.

**Notice!** You must install the ENTIRE handrail BEFORE tightening the steel wire.

## Preparación (Figura A)

- Seleccione el plan de suelo necesario - véase la página 5..
- Alterne las dimensiones más anchas en los peldaños consecutivos de tramos rectos con un ángulo inferior a 20°
- Si el ángulo de dos peldaños consecutivos es superior a 20°, las dimensiones más anchas de los peldaños deben estar orientadas hacia fuera - véase la Figura A2 y A3, página 5.

## Procedimientos previos a la instalación

### IMPORTANTE

Antes de iniciar la instalación, calcule la altura exacta de cada peldaño de la escalera. Esta distancia se calcula midiendo verticalmente la distancia desde el piso inferior hasta el piso superior a lo largo de la pared y dividiendo el resultado por el número de elevaciones. El número de elevaciones es el mismo que el número de peldaños más 1, ya que se tiene en cuenta la distancia del último peldaño de la escalera hasta el piso superior.

**S** = (página 5)

Ejemplo: Borde superior del suelo hasta el borde superior del piso de arriba: 102", 12 elevaciones (11 peldaños + 1).

102" cm dividido por 12 = 8 1/2". Esta es la altura de elevación por peldaño.

La abertura en el techo no debe ser inferior a 51 1/4" para peldaños rectos.

Esto garantiza la comodidad a la hora de subir los peldaños.

Altura de elevación recomendada: 7 5/16" a 8 1/16"

Altura de elevación máxima: 7 5/16" a 8 1/16"

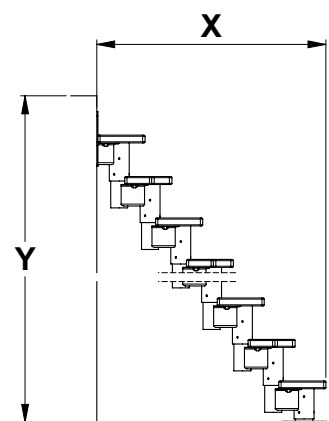

## Instalación (Figura 1 - 14)

ATENCIÓN: La escalera debe montarse de ARRIBA a ABAJO.

- Empiece a montar la escalera - consulte la figura (1).
- RECUERDE - Utilice la altura de peldaño calculada para instalar cada peldaño.
- RECUERDE - Utilice un soporte para estabilizar la escalera una vez que se hayan instalado los cuatro peldaños; véase la Figura 3.

Figura (4): Monte los dos peldaños por separado ANTES de instalarlos en la escalera – NO los apriete.  
A continuación, inserte los últimos dos peldaños, ajuste la altura de elevación calculada y apriete.

Figura (7): Instalación de los peldaños:  
Gire el lado ancho del peldaño superior hacia el pasamanos. A continuación, instale los peldaños de arriba hacia abajo, alternando derecha e izquierda.

**Advertencia:** Es más sencillo pretaladrar los peldaños del pasamanos antes de la instalación.

Utilice la plantilla suministradas; véase la página 11.

Coloque los peldaños en el medio del soporte. Compruebe la distancia (X); véase la figura (7) y la distancia (Y); véase la Figura (8).

**Advertencia:** Si el ángulo de los dos peldaños consecutivos es superior a 20°, los peldaños deben girarse de la misma forma con las dimensiones anchas hacia fuera; véase la Figura A2 y A3 en la página 5.

Figura (9–13), (14):

Instalación del pasamanos:

Empiece en el peldaño superior y fije los balaustres cada dos peldaños.

Fije el balaustre del rellano superior al suelo y, a continuación, monte el pasamanos en el balaustre instalado. Para completar el pasamanos, instale los cables en los balaustres.

**Advertencia:** Debe instalar el pasamanos COMPLETO ANTES de apretar los cables de acero.

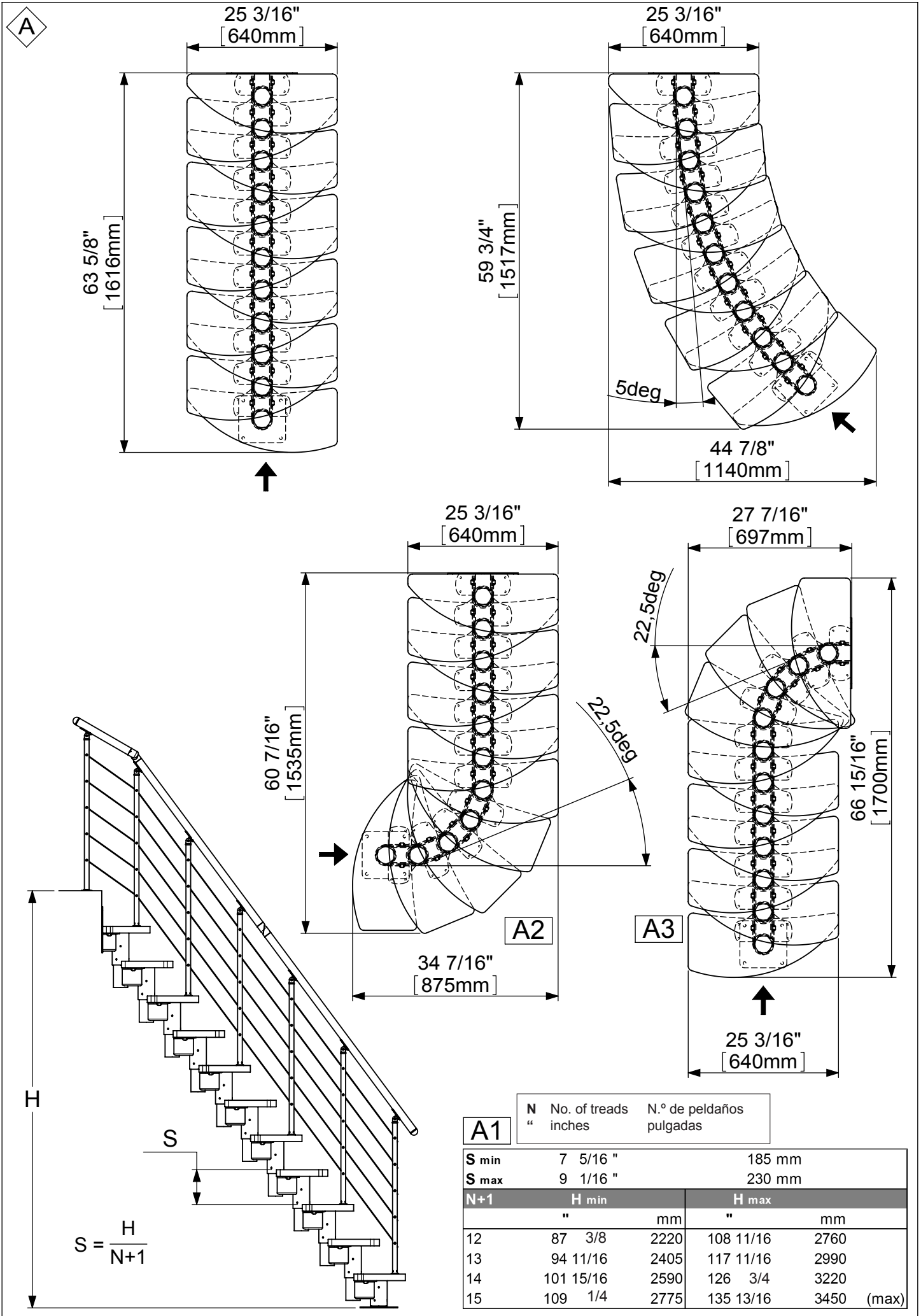



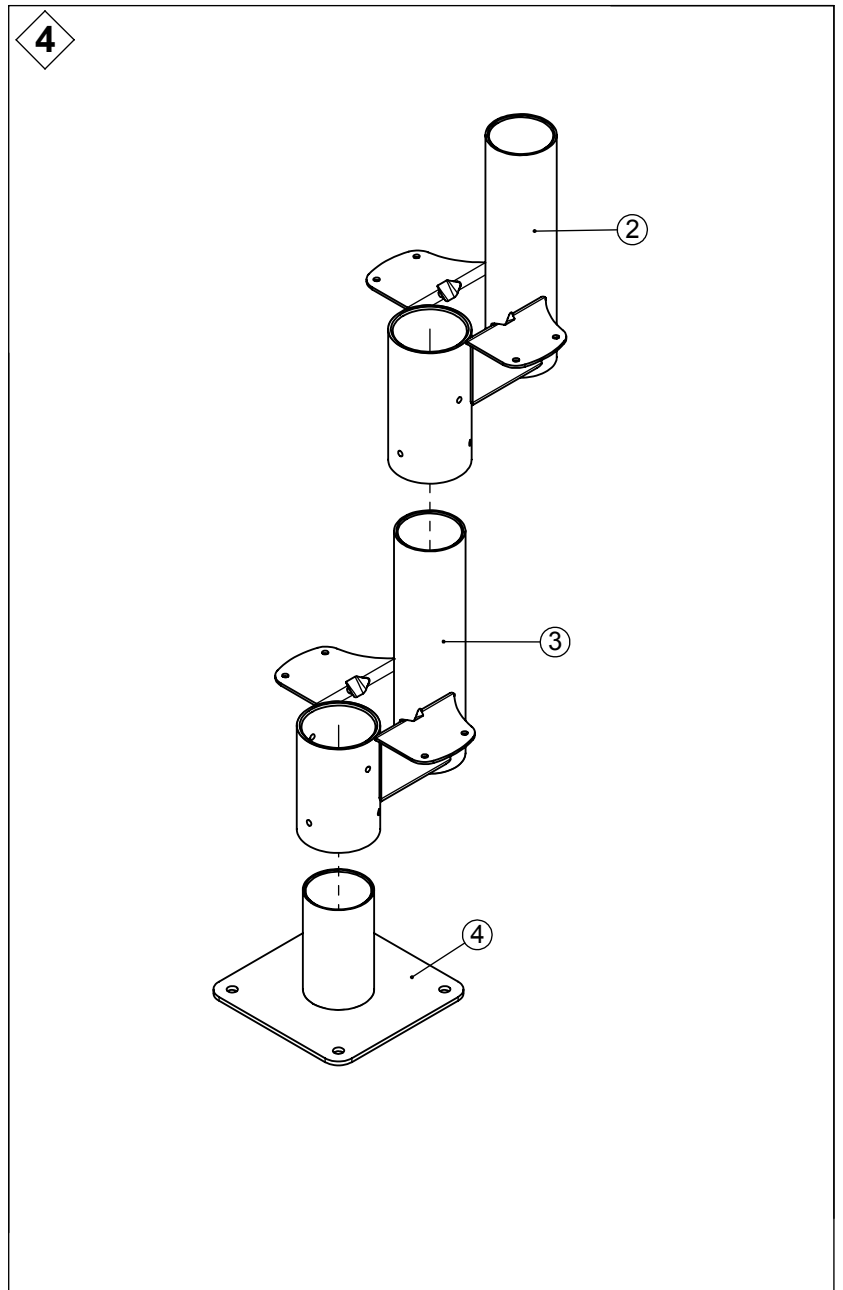
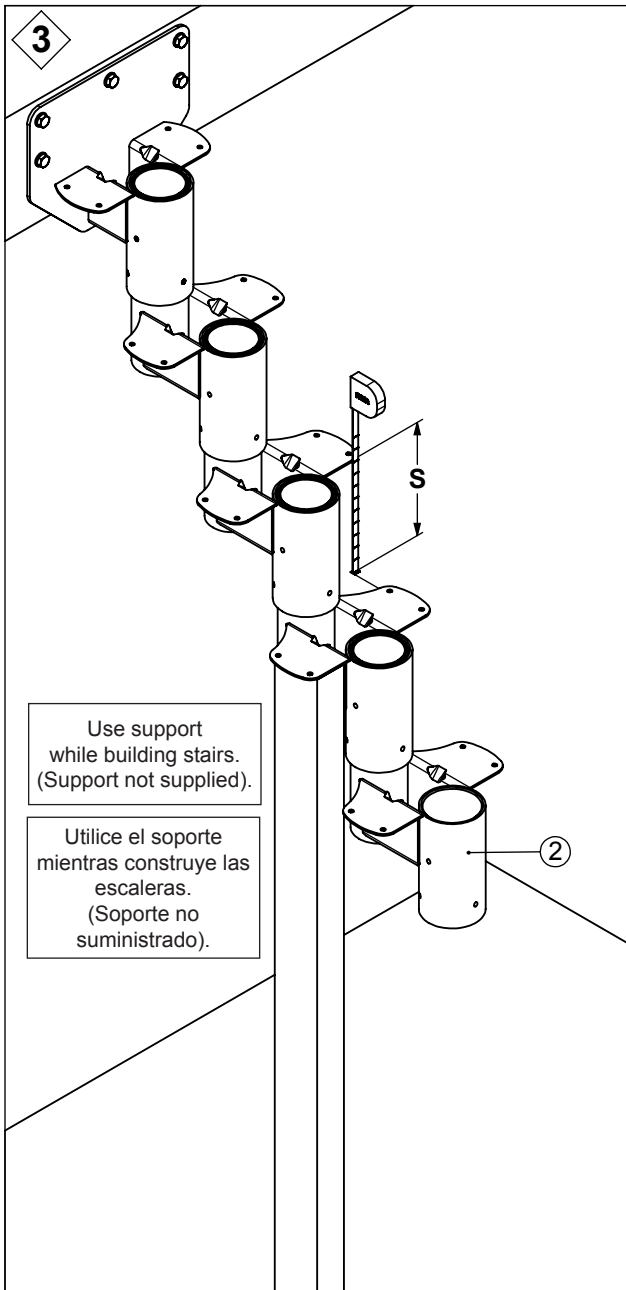
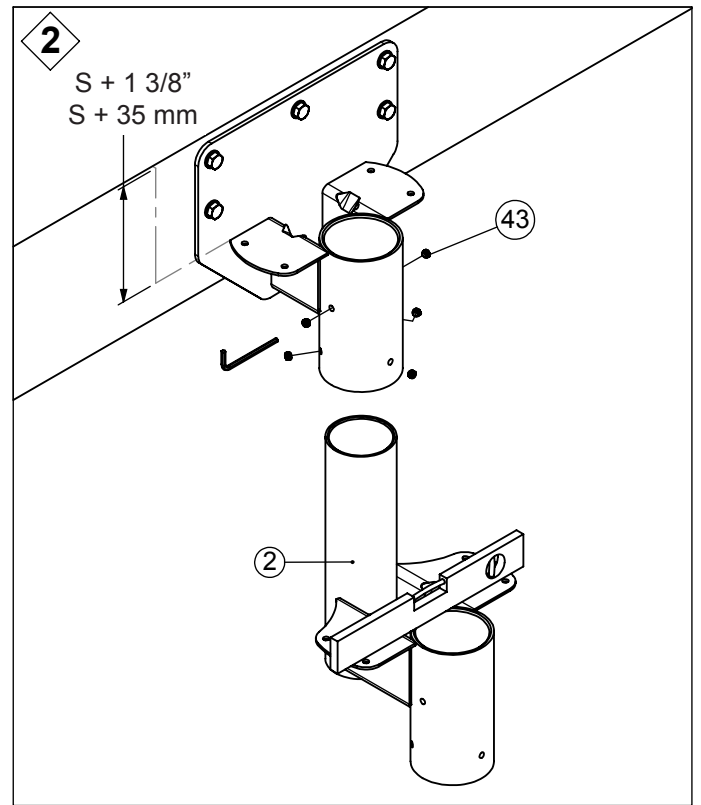
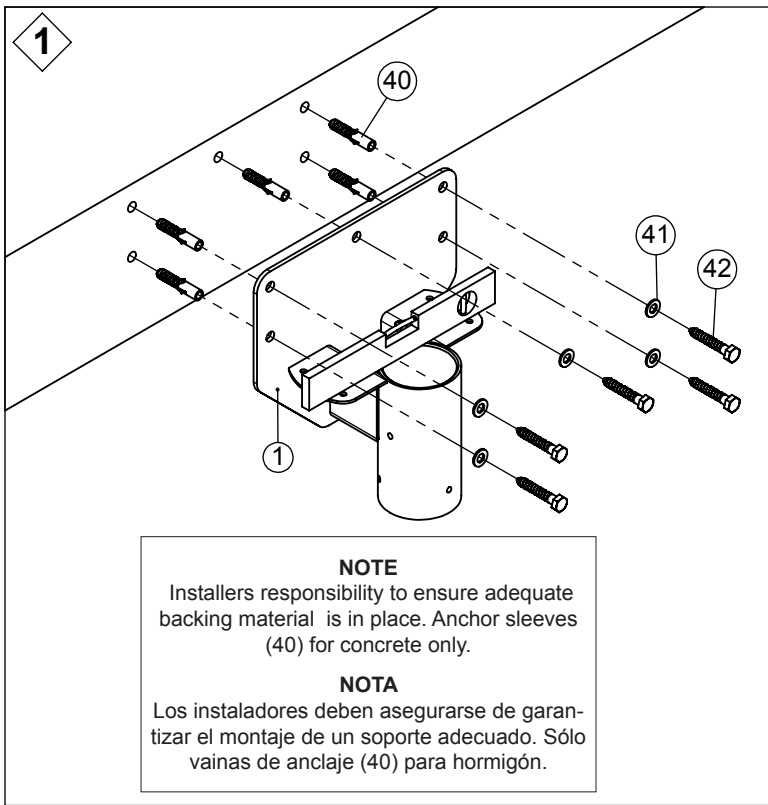

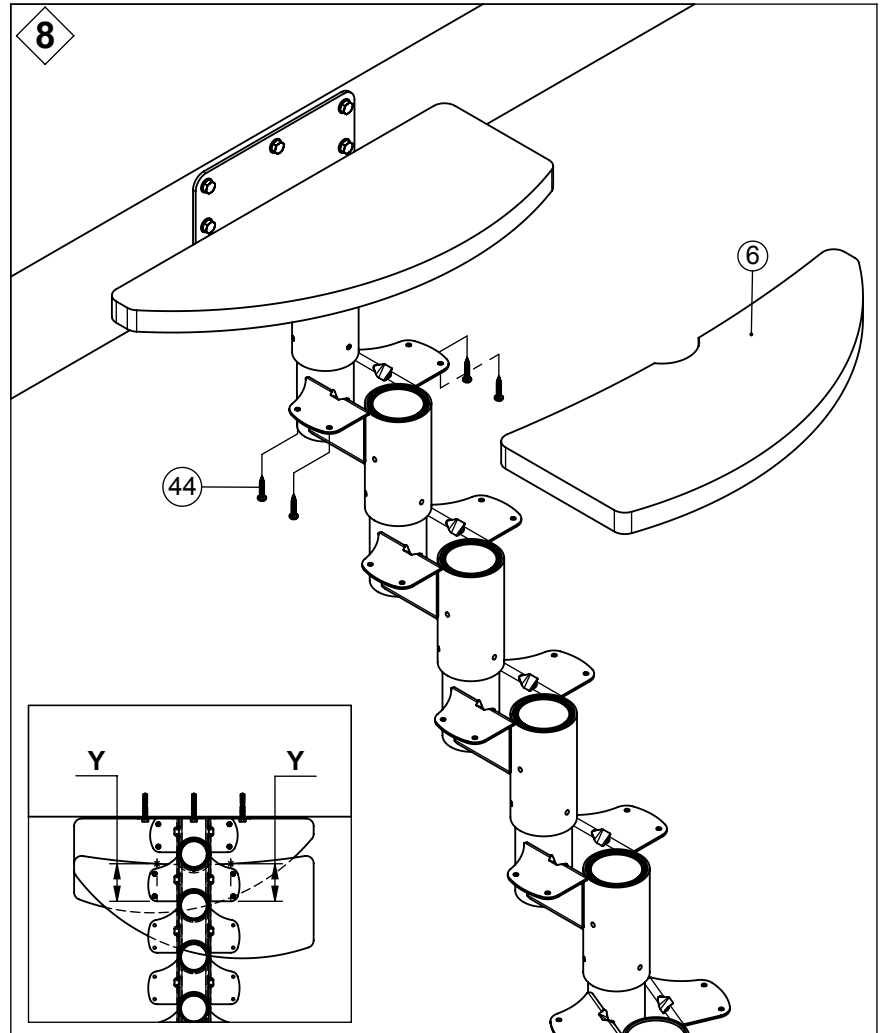
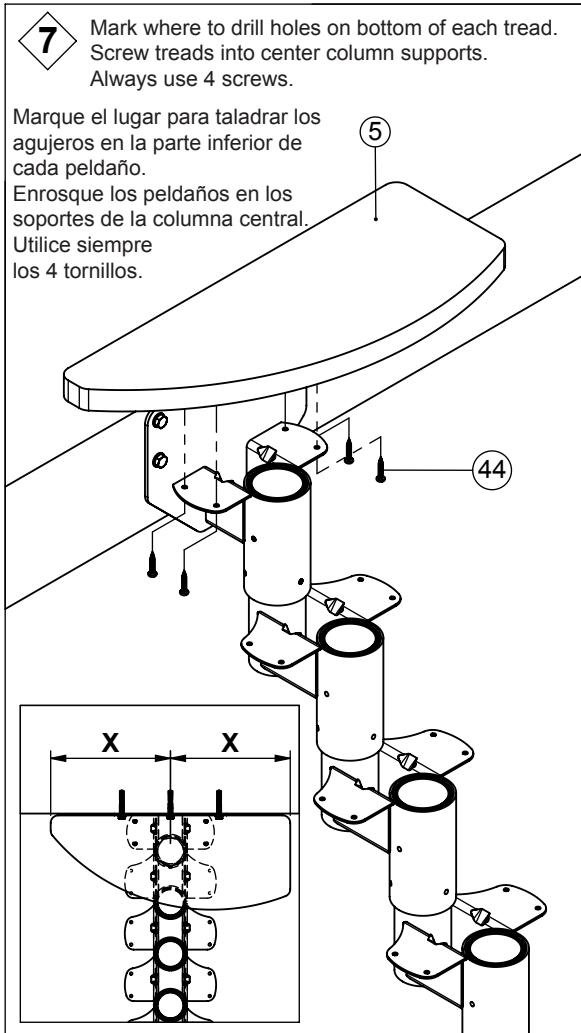
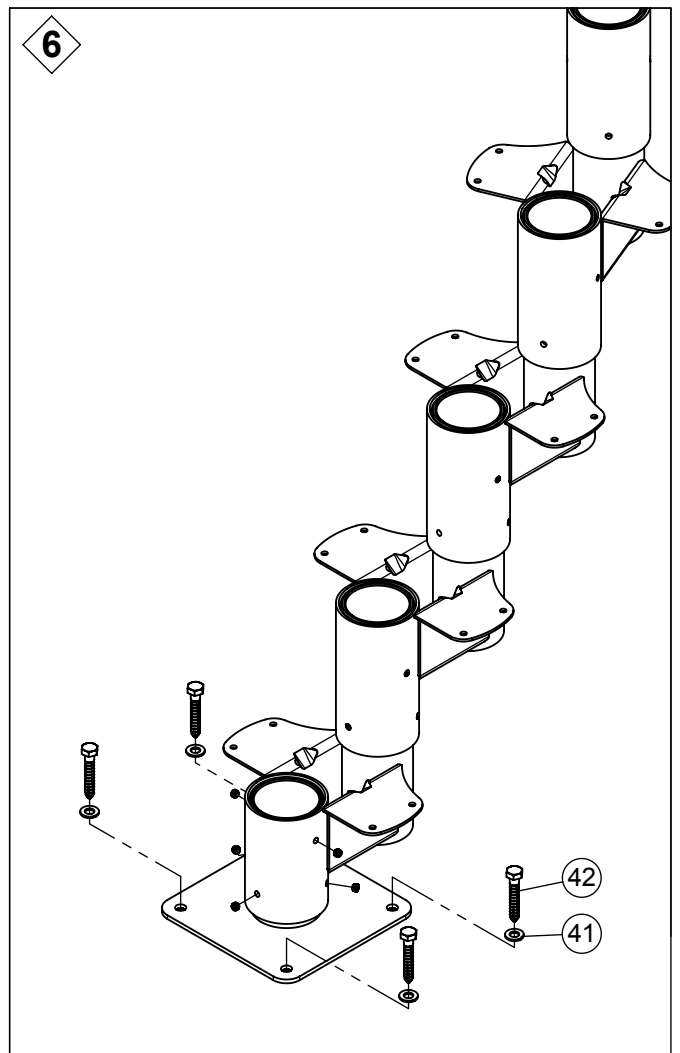
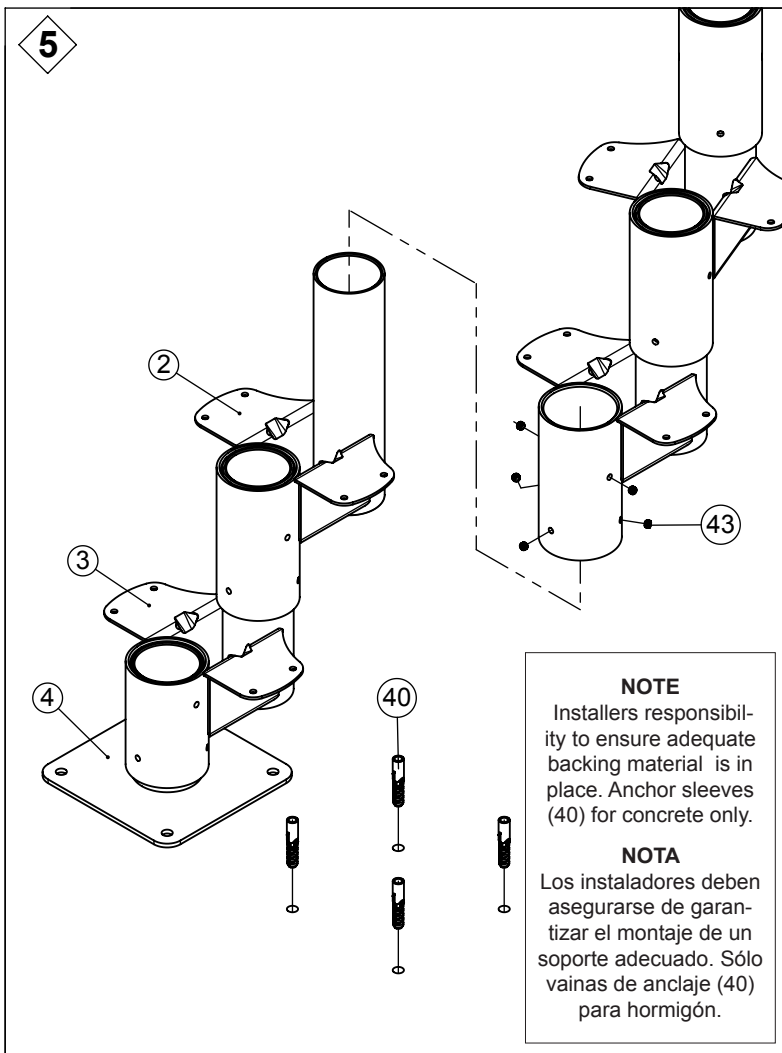



Tread: Drilling template  
Peldaño: Plantilla de perforación

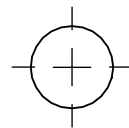

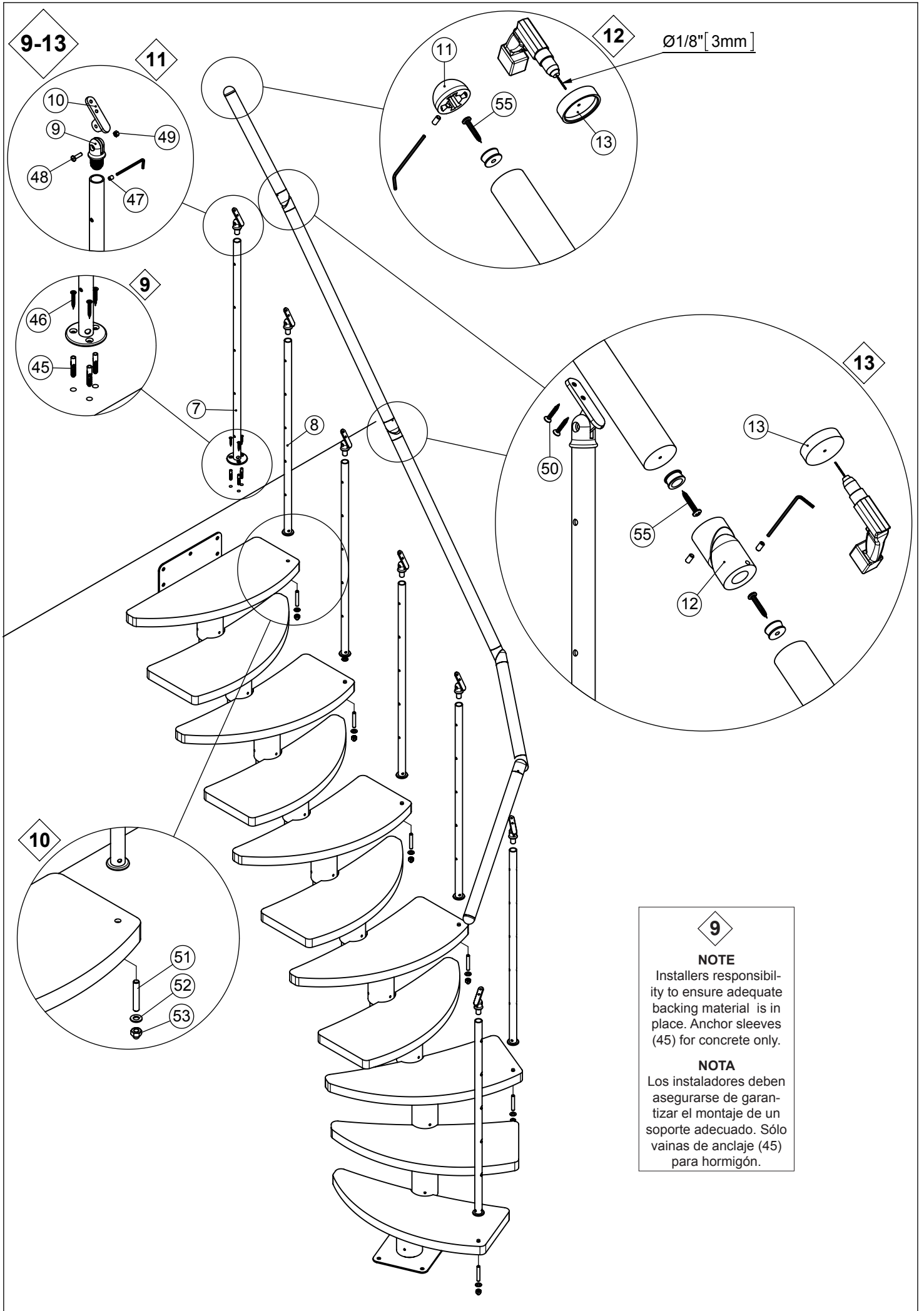

**9**

**NOTE**

Installers responsibility to ensure adequate backing material is in place. Anchor sleeves (45) for concrete only.

**NOTA**

Los instaladores deben asegurarse de garantizar el montaje de un soporte adecuado. Sólo vainas de anclaje (45) para hormigón.

