

**DOREL ASIA**

---

**PARSONS CHAIR**

**Model No:**

WM3738-DF  
DA3738-DFG

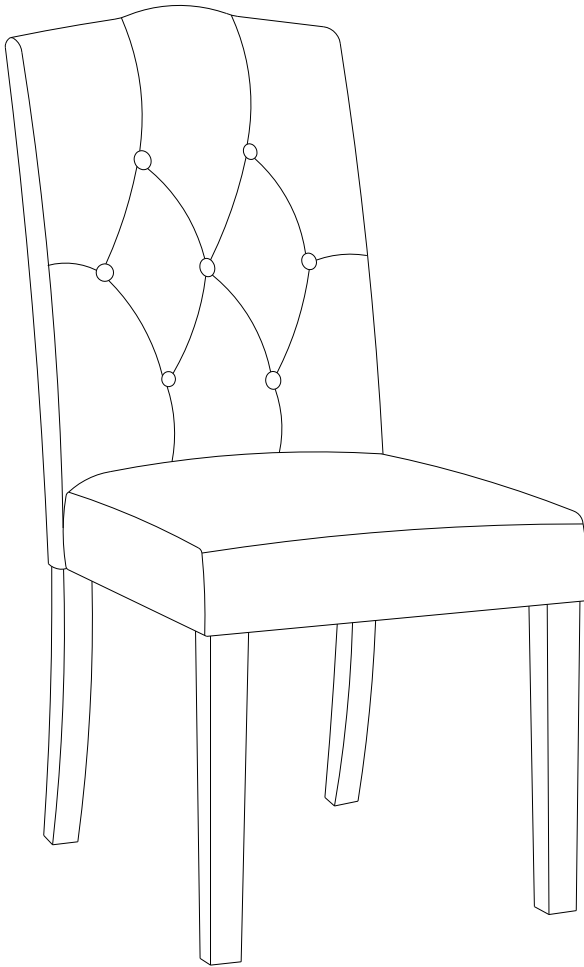

**UPC CODE:**

0-65857-16528-9  
0-65857-17096-2

**NOTE:**

THIS INSTRUCTION BOOKLET  
CONTAINS **IMPORTANT** SAFETY  
INFORMATION. PLEASE READ AND  
KEEP FOR FUTURE REFERENCE.

**Lot number:**

(TAKEN FROM CARTON)

\_\_\_\_\_

**Date of purchase:**

\_\_\_\_ / \_\_\_\_ / \_\_\_\_

**DO NOT RETURN PRODUCT TO THE STORE.**

If a part is missing or damaged, contact our customer service  
department. We will replace the part **FREE** of charge.



Tel #: 1-800-295-1980

E-Mail: [das@dorel.com](mailto:das@dorel.com)

Fax #: 514-353-7819

## CUSTOMER SERVICE

If you are missing parts or have any questions about this product, contact our customer service representative first!

 **CALL 1-800-295-1980**

You can also order parts by writing to the address listed below. Please include the product model number, color and a detailed description of the part.

**Customer Service Department No. 413  
12345 Albert-Hudon Boulevard, Suite 100  
Montreal, Quebec  
Canada H1G 3L1**

**E-MAIL: [das@dorel.com](mailto:das@dorel.com)**

## NOTES

- \* Ensure all parts and components are present before beginning assembly.
- \* Assemble on a soft, smooth surface to prevent damage to product finish.
- \* **DO NOT** use power tools.
- \* **CAUTION:** Adult assembly required.
- \* Assembly and handling will require two people.
- \* Estimated assembly time: 15 minutes.

## CARE AND CLEANING

Dust regularly with a soft, dry cloth to prevent soil build up. Keep away from heat to avoid glazing, melting or scorching. Use a professional cleaning service to clean the fabric.

## MAINTENANCE

Check bolts/screws periodically and tighten them if necessary.

## LIMITED WARRANTY

Dorel Asia warrants its product to be free from defects in material and workmanship and agrees to remedy any such defect. This warranty covers 1 year from the date of original purchase. This warranty is valid only upon presentation of proof of purchase. This is solely limited to the repair or replacement of defective furniture components and no assembly labor is included. This warranty does not apply to any product which has been improperly assembled, subjected to misuse or abuse or which has been altered or repaired in any way. Any wearing, tearing, fading or splitting of the fabric is not covered under the warranty. This warranty gives you specific legal rights and you may also have other rights which vary from State to State.







**WARNING: Should this product become damaged, and/or components are broken or missing, DO NOT USE.**

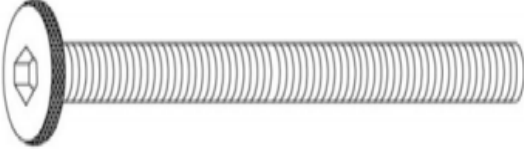

# PARSONS CHAIR

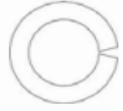
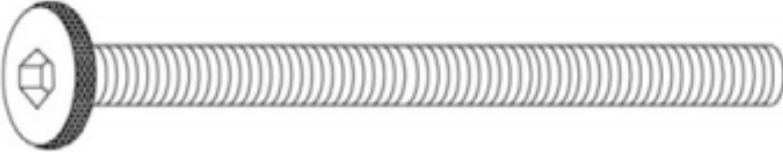
## WM3738-DF / DA3738-DFG

### HARDWARE LIST

1	 $\text{Ø}5/16'' \text{ X } 60\text{mm}$	2	 $\text{Ø}22 \text{ X } 1.8\text{mm}$	3	 $\text{Ø}12.5 \text{ X } 1.2\text{mm}$
HEX SOCKET HEAD BOLT 6 PCS		FLAT WASHER 10 PCS		SPRING WASHER 10 PCS	
4	 $\text{Ø}5/16'' \text{ X } 90\text{mm}$			5	
HEX SOCKET HEAD BOLT 4 PCS				ALLEN KEY 1 PC	

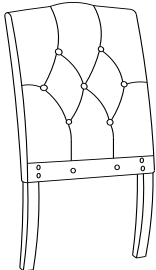
### PARTS LIST

A		B		C	
BACK FRAME 1 PC		SEAT FRAME 1 PC		FRONT LEG 2 PCS	

# PARSONS CHAIR

## WM3738-DF / DA3738-DFG

### STEP 1:

Place back frame (A) on a clean, smooth surface.

Remove the fabric lining underneath seat frame (B).

Attach the seat frame (B) to back frame (A) with flat washers (2), spring washers (3) and hex socket head bolts (1) through the center of the seat frame (B).

Use Allen key (5) to tighten the bolts.

NOTE: Do not fully tighten bolts.

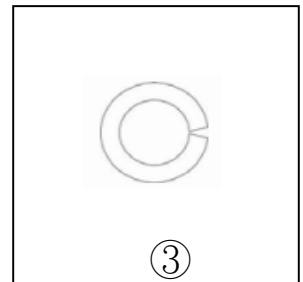
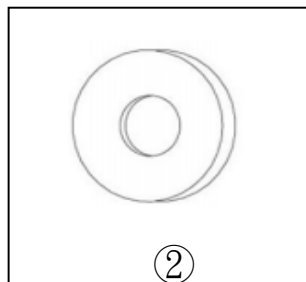
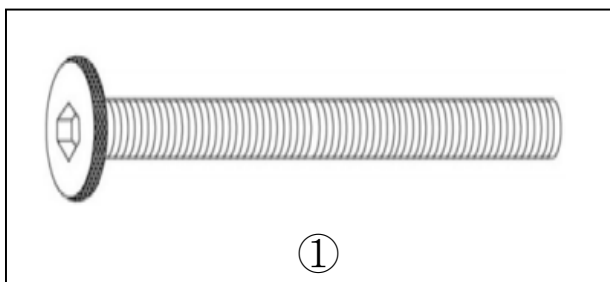
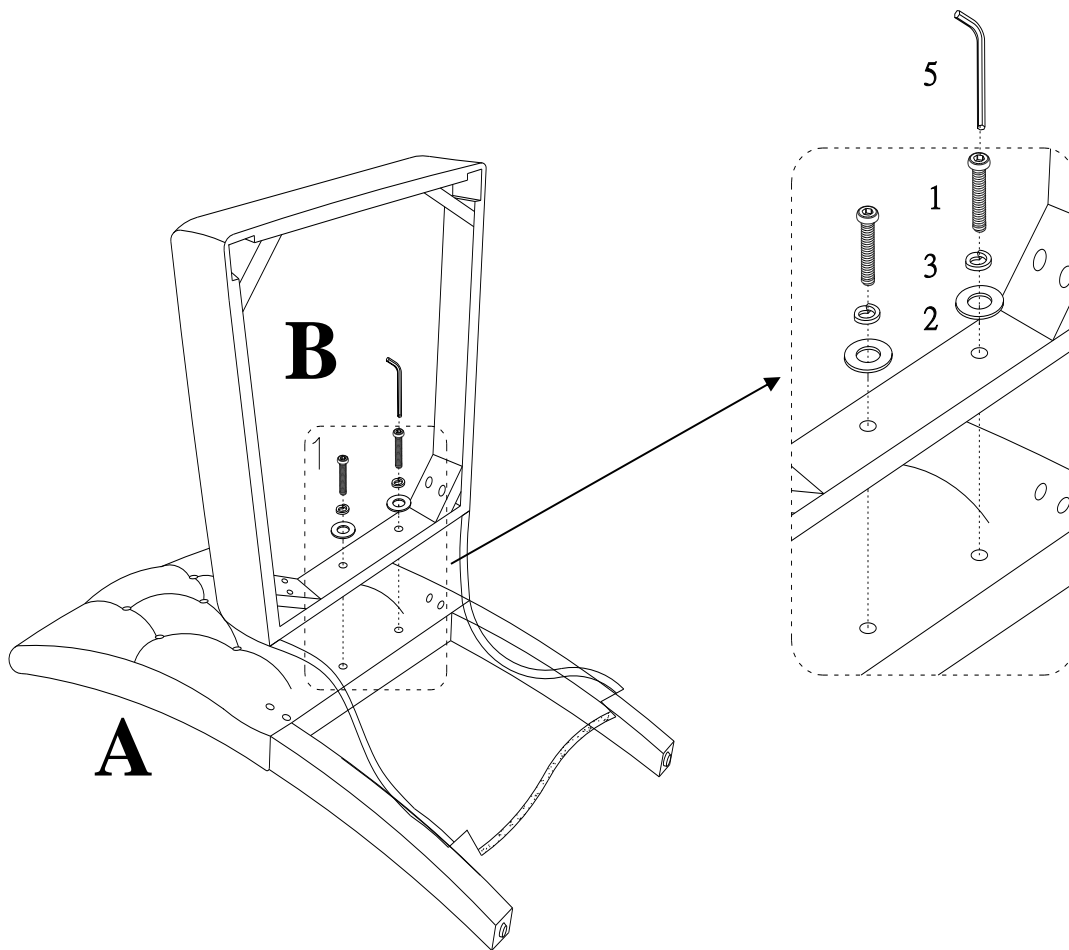

# PARSONS CHAIR

## WM3738-DF / DA3738-DFG

### STEP 2:

Secure seat frame (B) to back frame (A) with flat washers (2), spring washers (3) and hex socket head bolts (4).

Use Allen Key (5) to tighten the bolts.

NOTE: Do not fully tighten bolts.

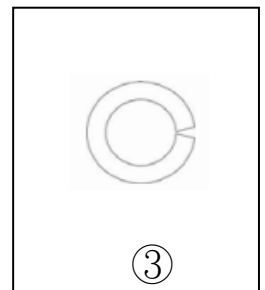
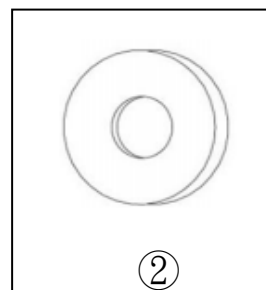
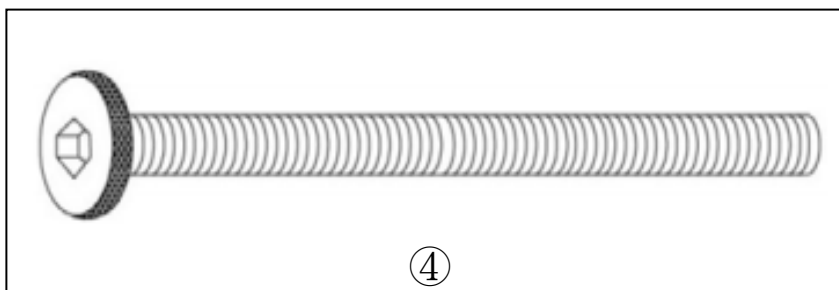
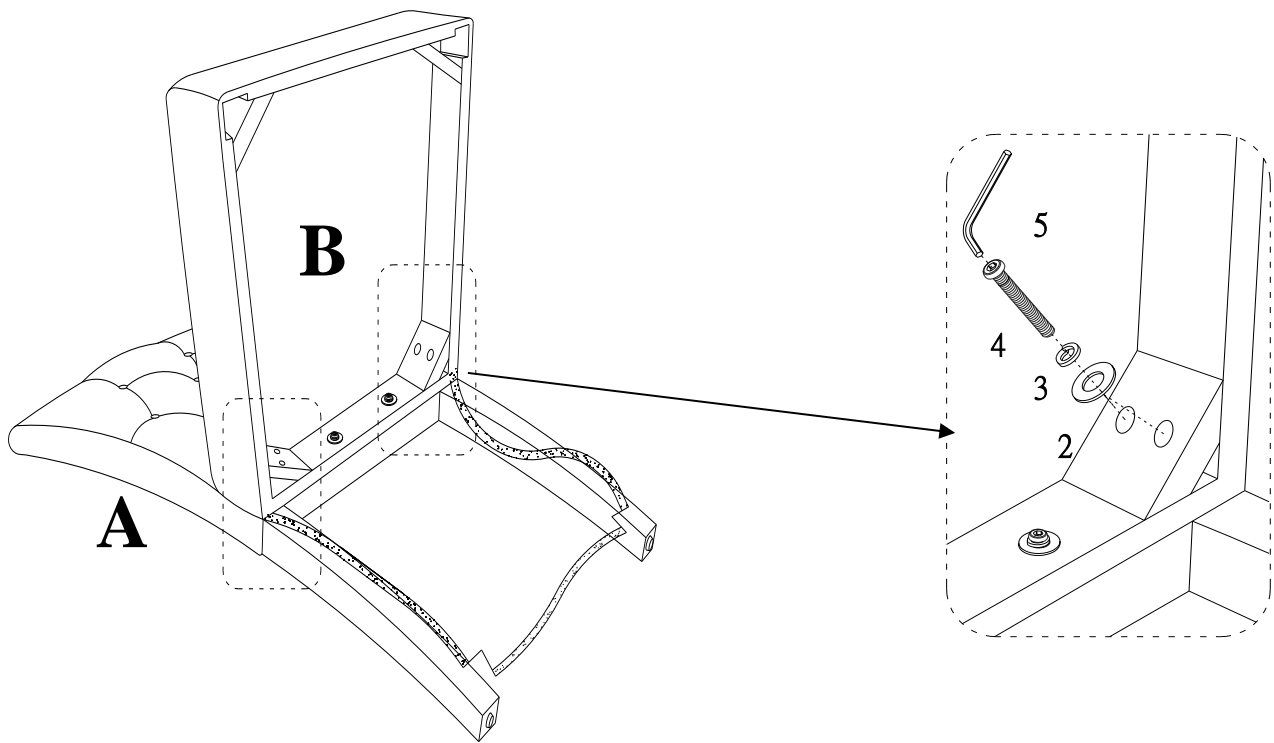

# PARSONS CHAIR

## WM3738-DF / DA3738-DFG

### STEP 3:

Attach front legs (C) to seat frame (B) with flat washers (2), spring washers (3) and hex socket head bolts (1). Use Allen key (5) to tighten the bolts. Tighten all bolts previously installed. Place the fabric lining back into place.

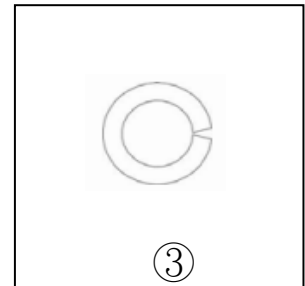
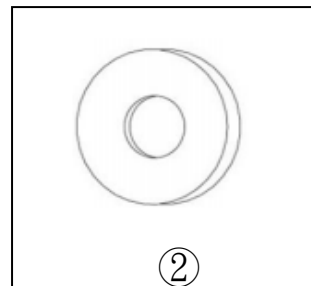
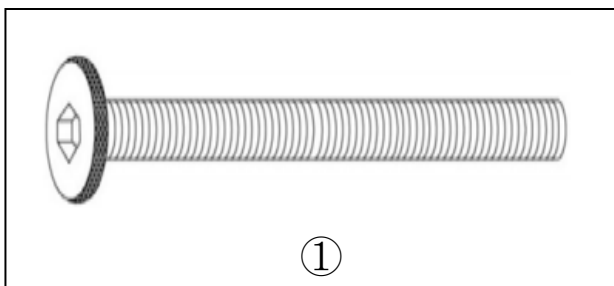
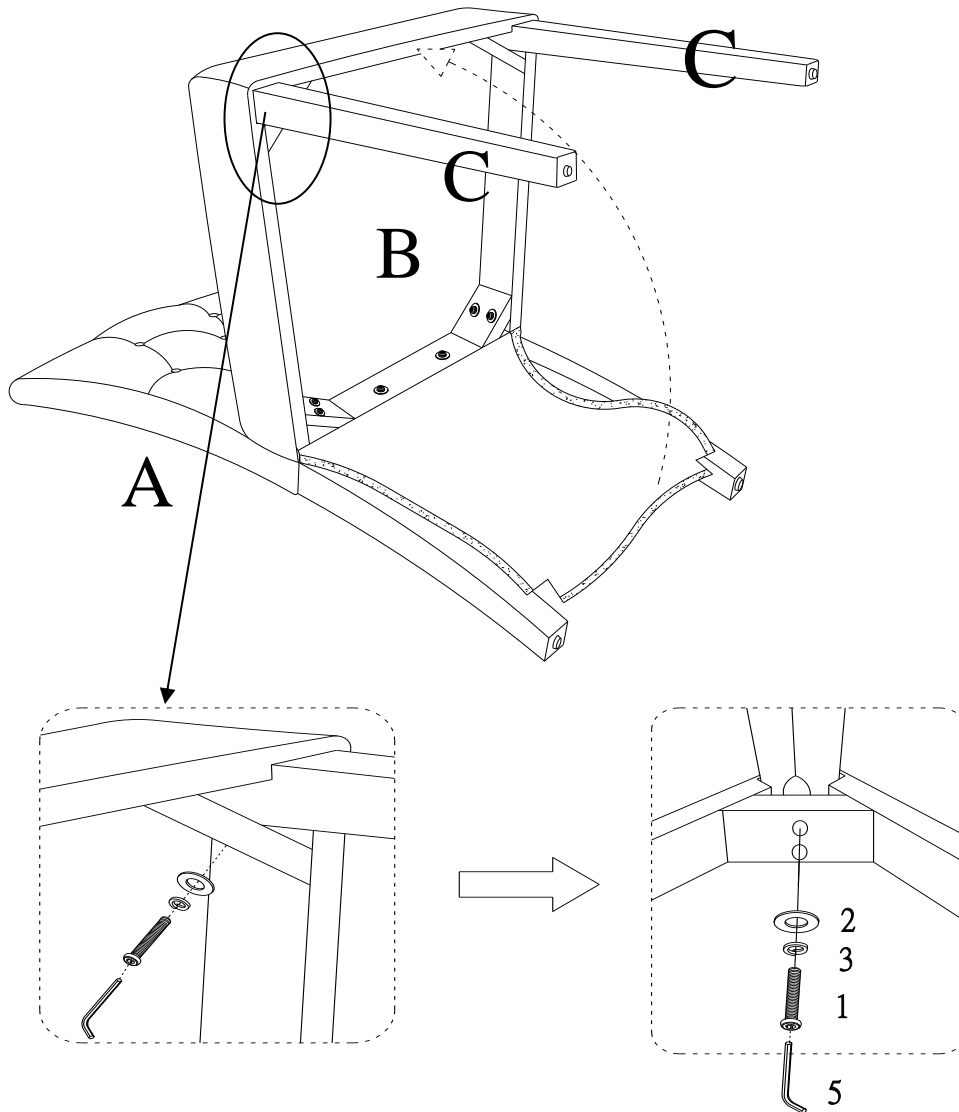

# PARSONS CHAIR

## WM3738-DF / DA3738-DFG

### STEP 4:

Turn the chair upright.

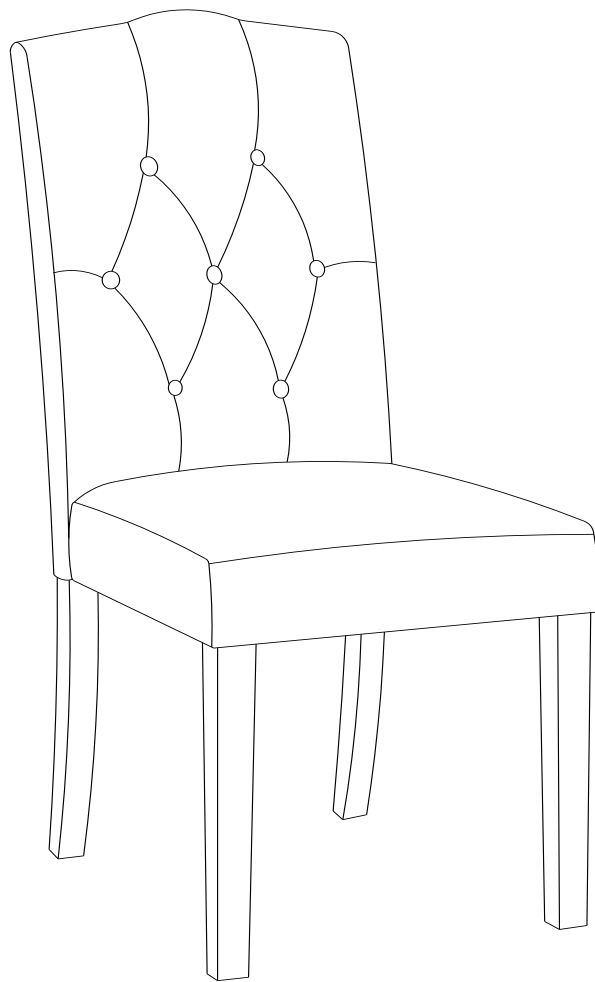

**Note:** Legs are equipped with adjustable levelers. Before placing this item in the desired location, make sure that the chair rests evenly on the floor by turning the adjustable levelers clockwise or counterclockwise (as needed).

# PARSONS CHAIR

## WM3738-DF / DA3738-DFG



**CAUTION:** This unit is intended for use only with the products and/or maximum weights indicated. Use with other products and/or products heavier than the maximum weights indicated may result in instability or cause possible injury.

Dust regularly with a soft, dry cloth to prevent soil build up. Keep away from heat to avoid glazing, melting or scorching. Use a professional cleaning service to clean the fabric.

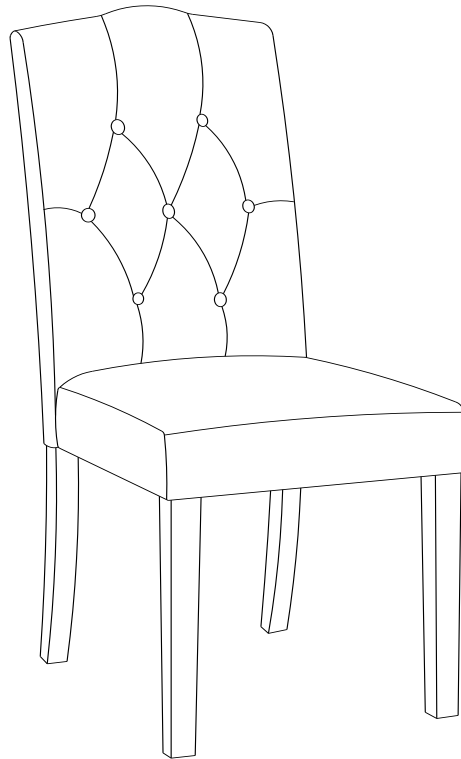

That's it ! You've finished assembling your chairs.

**DO NOT RETURN PRODUCT TO THE STORE.**

If a part is missing or damaged, contact our customer service department. We will replace the part **FREE** of charge.



Tel #: 1-800-295-1980  
E-Mail: [das@dorel.com](mailto:das@dorel.com)  
Fax #: 514-353-7819



# Customer Service

**PLEASE DO NOT RETURN THIS PRODUCT TO THE STORE**

**PLEASE CONTACT CUSTOMER SERVICE REPRESENTATIVES AT THE FOLLOWING NUMBERS SHOULD THERE BE ANY MISSING OR DEFECTIVE PART(S).**

Customer Service Phone Number 1-800-295-1980	Email: <a href="mailto:das@dorel.com">das@dorel.com</a>
Customer Service Fax Number 514-353-7819	

Request Date:

Name:

Shipping Address:

Street & Number:

City & State:

Zip Code:

Day Time Phone Number:

(including area code)

Date & Place of Purchase:

Part(s) description and quantity (Please be sure to list model number or SKN number):

Customer Service Representative Mailing Address:

Customer Service Department No. 413, 12345 Albert-Hudon Boulevard, Suite 100, Montreal, QC, Canada, H1G 3L