



Maxx Cold X-series | The Legacy Companies  
 3355 Enterprise Avenue, Suite 160, Fort Lauderdale, FL 33331  
 (954) 202-7419 • Fax (954) 202-7337 • (877) 600-8401  
 www.MaxximumFoodService.com • Info@MaxxColdFoodService.com

Project Name: \_\_\_\_\_

Location: \_\_\_\_\_

Item #: \_\_\_\_\_ Qty: \_\_\_\_\_

Model: \_\_\_\_\_

# GLASS DOOR MERCHANDISER | 12 Cu Ft REFRIGERATOR

Model:  MXM1-12R  MXM1-12RB



MXM1-12R



MXM1-12RB  
(Color: Black)

Glass Door merchandisers are designed for durability and visual appeal in promoting your product. Glass door merchandisers are energy efficient and effective at keeping product at exactly the right temperature. This keeps food fresher for longer. The simple-to-use but precise digital controls allows for accuracy in temperature and flexible use of the unit.

## FEATURES

- Hinged Door Models: Self-closing, magnetic gasket
- Double pane insulated glass glass doors enhance energy efficiency by preventing heat transfers and minimizing condensation
- Interior LED lighting
- Bottom mounted oversized compressor
- (3) shelves. Heavy-duty, PE (polyethylene) coated wire shelves.
- Pre-programmed automatic defrost cycle for optimal, trouble-free storage conditions.
- Temperature reading visible from up to 15 feet away
- Door lock
- Adjustable feet for uneven flooring.

## TEMPERATURE

- Holding temperature: 32° to 40°F (0° to 4°C)
- Digitally controlled system maintains optimum temperature

## CONSTRUCTION

- Exterior Material: Powder coated steel.
- Interior Material: Powder coated aluminium. Easy to clean, low maintenance.

## REFRIGERANT

- CFC & HCFC free R-134A



## ELECTRIC

Single Door: 115/60Hz/1 Ph (NEMA 5-15)



Certified to  
ANSI-NSF 7



Certified to  
ANSI UL 471



EPA  
Compliant



DOE 2017  
Compliant

Due to periodic changes in designs, methods, procedures, policies and regulations, the specifications contained in this sheet are subject to change without notice. While we exercise good faith efforts to provide information that is accurate, we are not responsible for errors or omissions in information provided or conclusions reached as a result of using the specifications.

By using the information provided, the user assumes all risks in connection with such use.

The built in performance enhancing functions ensure that given proper attention and preventative maintenance, each Maxx Product will deliver years of trouble free, reliable, low maintenance, efficient operation.

# GLASS DOOR MERCHANDISER | 12 Cu Ft REFRIGERATOR

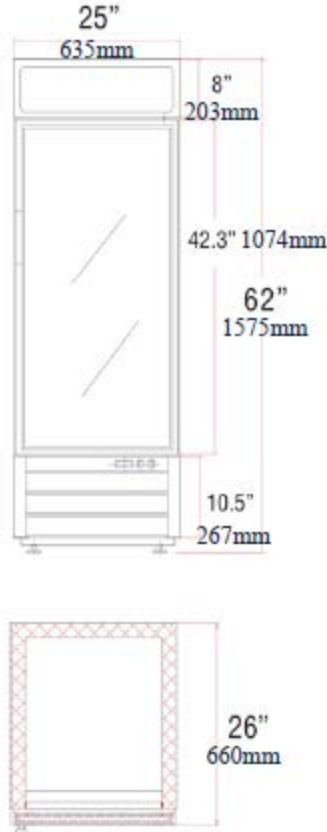

	MXM1-12R
<b>In: External Dimensions W x D X H</b>	25 x 26 x 62
<b>mm: External Dimensions W x D X H</b>	635 x 660 x 1575
<b>In: Internal Dimensions W x D X H</b>	20.125 x 21.75 x 36
<b>mm: Internal Dimensions W x D X H</b>	512 x 553 x 914
<b>Nominal Capacity</b>	12 Cu Ft / 340 L
<b>Doors</b>	1
<b>Shelves</b>	(3) shelves
<b>Amps (Watts)</b>	6 Amps
<b>Unit Weight</b>	221 lb / 100 kg

Due to periodic changes in designs, methods, procedures, policies and regulations, the specifications contained in this sheet are subject to change without notice. While we exercise good faith efforts to provide information that is accurate, we are not responsible for errors or omissions in information provided or conclusions reached as a result of using the specifications. By using the information provided, the user assumes all risks in connection with such use.