

Switch with Wi-Fi Technology

decora smart



APPLICATION

Control connected loads and lights from anywhere using Wi-Fi, an internet connection and the free My Leviton app; that is all you need, no hub required. Simplify control of the residence - schedule lights and connected loads to turn on/off at specific times or based on sunrise/sunset, easily group smart devices into rooms, and create scenes to activate multiple lights at once. Customize your experience with adjustable fade rates, maximum/minimum illumination levels, and more if desired. Supports LED and CFL technologies up to 600 Watts along with support for legacy incandescent lighting loads up to 1800 Watts, along with support for Fluorescent, Resistive, and Motor loads.

AMAZON ALEXA VOICE CONTROL

Compatible with all products that support Amazon Alexa providing voice control of the load: "Alexa, turn on living room lights". Alexa devices (including Echo, Dot, and Tap) sold separately.

LOW-WATTAGE LED LOADS

The new lighting control accessories are engineered to function with extremely sensitive, low-wattage light sources, such as a single LED bulb in a hallway or a strand of holiday lights, ensuring LEDs do not glow when off.

AESTHETICS

Switches leverage the popular Decora form factor and styling, along with compatible accessories including three-way devices, color change kits, and wallplates. The switches feature true rocker action, pressing the

top to turn on and the bottom to turn off. To meet any decor, color change kits are available in white, ivory, light almond, gray, black, and brown. For the most professional and cleanest installation, pair the device with an optional Leviton screwless wallplate.

BENEFITS

- Control your lights from anywhere using the free My Leviton app for iOS and Android, no hub required.
- Amazon Alexa products provide voice control: "Alexa, turn on living room lights". (Echo, Tap, and Dot sold separately).
- Simplify control of your home - schedule lights and connected loads to turn on/off at specific times or based on sunrise/sunset, easily group your smart devices into rooms, and create scenes to activate multiple lights at once.

FEATURES

- White and Light Almond color faces included
- Rated for CFL and LED loads up to 600W
- Rated for incandescent loads up to 1800W
- Multi-location (3-way) switching is achieved using DD0SR-1 Coordinating Remote (no LED indicator) or DD0SR-DLZ Matching Remote (with LED indicator).

AGENCY STANDARDS AND COMPLIANCE

- Complies with UL 917
- CSA Certified to Standard 177

RATINGS

- Incandescent - 1800W - 120VAC, 60Hz
- LED/CFL - 5A, 600W - 120VAC, 60Hz
- Fluorescent - 15A - 120VAC, 60Hz;
8A - 277VAC, 60Hz
- Resistive - 15A - 120VAC, 60Hz
- Motor - 1/2 HP - 120VAC, 60Hz

WARRANTY INFORMATION

Five-Year Limited Warranty

Leviton Manufacturing Co., Inc. Global Headquarters

201 N. Service Rd. Melville, NY 11747-3138 Tech Line: 1-800-824-3005 Fax: 1-800-832-9538

Leviton Manufacturing Co., Inc. Energy Management, Controls and Automation.

4330 Michoud Blvd., New Orleans, LA, 70129 Tel: 1-504-736-9810 Fax: 1-504-253-2954

Visit our Website at: www.leviton.com/decorasmart

©2017 Leviton Manufacturing Co., Inc. All rights reserved. Subject to change without notice.

SINGLE POLE WIRING DIAGRAM

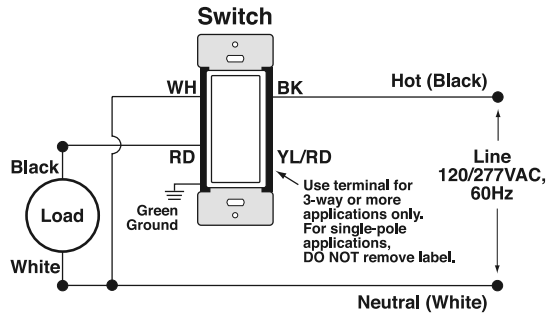

THREE-WAY WIRING DIAGRAM

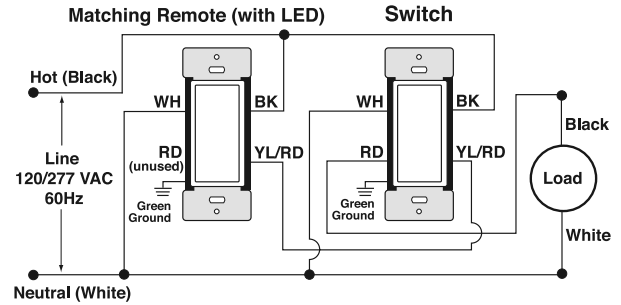

ORDERING INFORMATION

DESCRIPTION	CAT. NO.
15A Switch with Wi-Fi Technology	DW15S-1BZ
Coordinating Switch Remote	DD0SR-1
Matching Switch Remote	DD0SR-DLZ

Switch with Wi-Fi Technology

Leviton Manufacturing Co., Inc. Global Headquarters

201 N. Service Rd. Melville, NY 11747-3138 Tech Line: 1-800-824-3005 Fax: 1-800-832-9538

Leviton Manufacturing Co., Inc. Energy Management, Controls and Automation.

4330 Michoud Blvd., New Orleans, LA, 70129 Tel: 1-504-736-9810 Fax: 1-504-253-2954

Visit our Website at: www.leviton.com/decorasmart

©2017 Leviton Manufacturing Co., Inc. All rights reserved. Subject to change without notice.

SAT-10113
REV FEB 2017