

# Earthquake®

GROUNDBREAKING POWER EQUIPMENT

Illustrated Parts Breakdown  
Illustration des pièces détachées

## Edger

with Multi-Position Cutting Head

**Model Number, Numéros de modèle :**  
**23275, 24000**

ENGLISH

FRANÇAIS

S/N

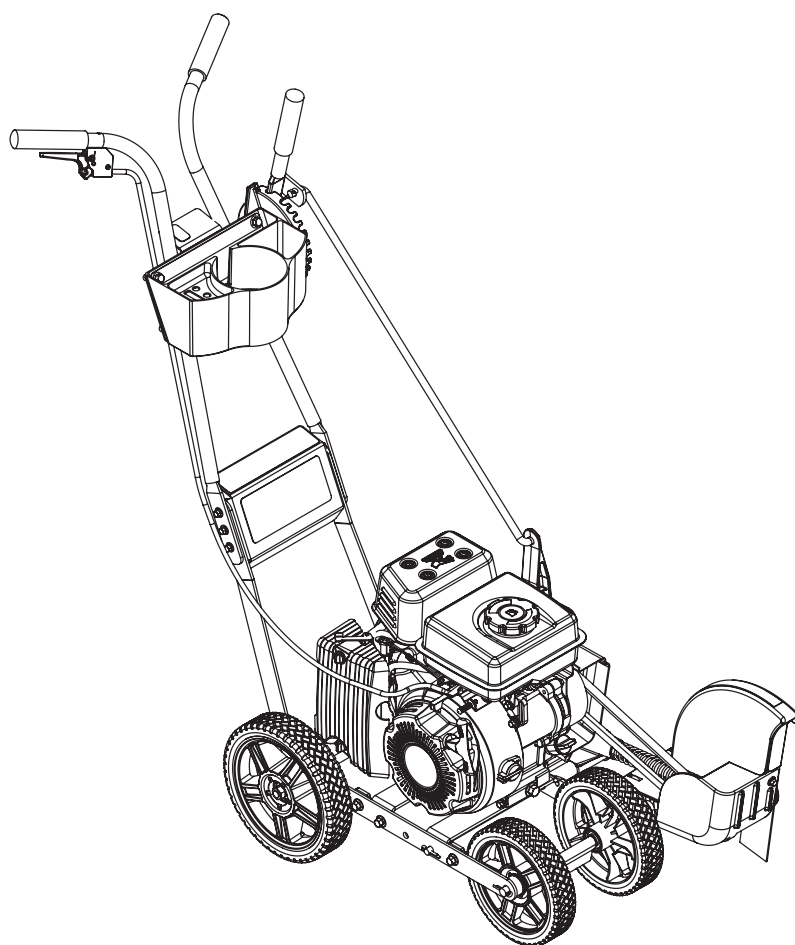

Get parts or technical assistance online at  
**[www.getearthquake.com](http://www.getearthquake.com) or call (800) 345-6007**  
Pièces détachées et assistance technique en ligne à  
**[www.getearthquake.com](http://www.getearthquake.com) ou composer le (800) 345-6007**

© 2020 Ardisam  
All Rights Reserved  
Tous droits réservés  
P/N: 32445  
ECN: 12613  
REV 1: 03/05/2020



THIS INSTRUCTION BOOKLET CONTAINS IMPORTANT SAFETY INFORMATION. PLEASE READ AND KEEP FOR FUTURE REFERENCE.  
CE LIVRET D'INSTRUCTIONS CONTIENT DES INFORMATIONS IMPORTANTES SUR LA SÉCURITÉ. VEUILLEZ LE LIRE ET LE CONSERVER POUR TOUTE CONSULTATION EXTÉRIEURE.

**ILLUSTRATED PARTS BREAKDOWN / ILLUSTRATION DES PIÈCES DÉTACHÉES - Engine & Cutting Head**

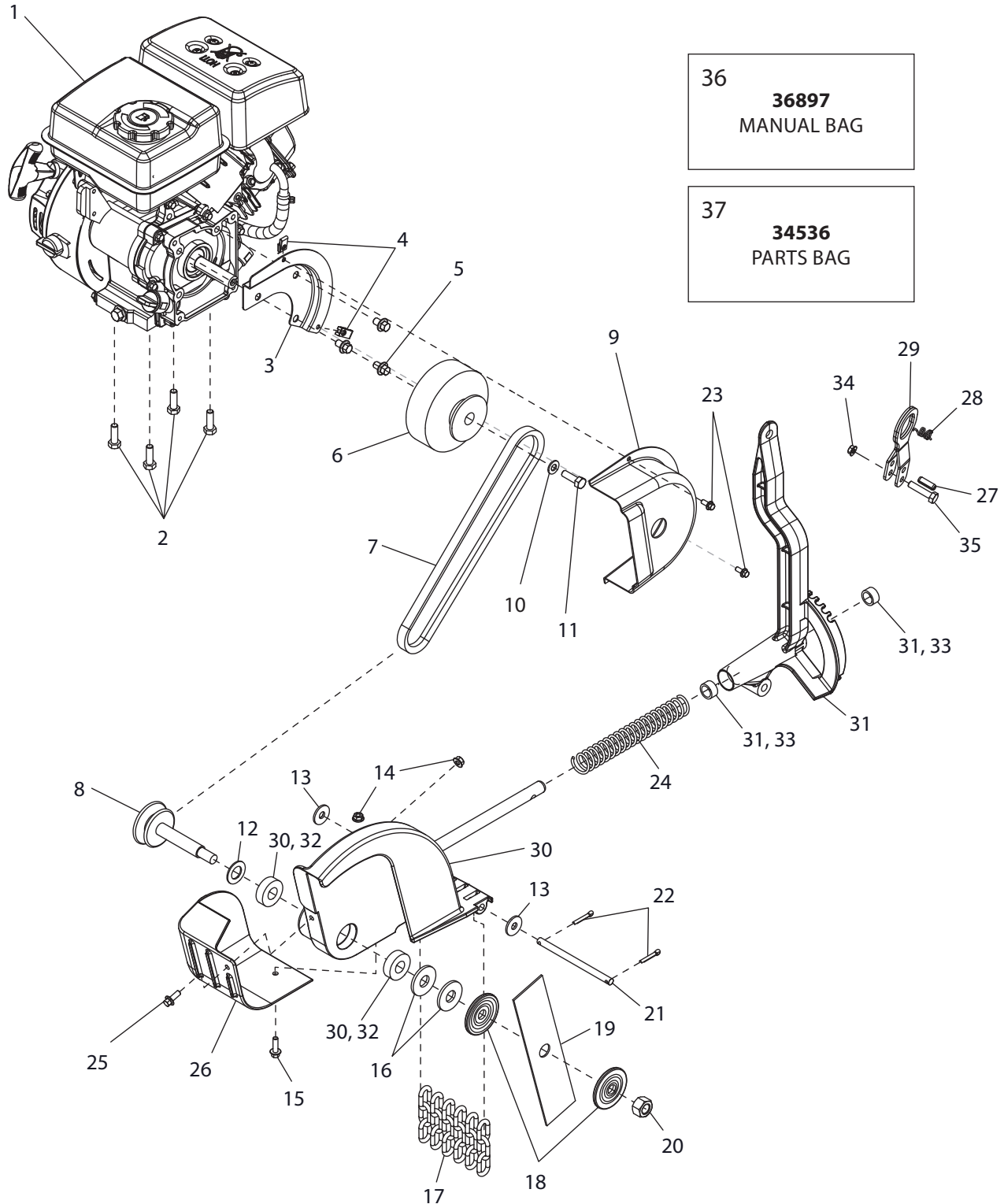

36  
**36897**  
MANUAL BAG

37  
**34536**  
PARTS BAG

**ILLUSTRATED PARTS BREAKDOWN / ILLUSTRATION DES PIÈCES DÉTACHÉES - Engine & Cutting Head**

REF. / REP.	PART NO. / N° RÉF.	DESCRIPTION	QTY. / QTÉ
1	25494	ENGINE R80V 79CC	1
2	24169	BOLT M8 X 25	4
3	23989	BRACKET CLUTCH SHIELD	1
4	23873	CAGE NUT M5	2
5	4711	BOLT M8 X 12	3
6	23487	CENTRIFUGAL CLUTCH	1
7	24021	BELT 13 X 785LA	1
8	24001	PULLEY WELDMENT	1
9	23645	CLUTCH SHIELD	1
10	26439	DRIVE SHAFT CAP M6	1
11	23511	BOLT M6 X 25	1
12	24148	WAVE WASHER M16	1
13	3245	WASHER M8	2
14	14109	NUT M6	2
15	25058	BOLT M6 X 20	1
16	24149	WASHER M14	2
17	23265	CHAIN LINK ASSEMBLY	6
18	23263	WASHER BLADE CLAMP	2
19	23262	BLADE	1
20	W1200129	NUT M14	1
21	24836	ROD CHAIN GUARD	1
22	22097	COTTER PIN 2 MM	2
23	400018	BOLT M5 X 12	2

REF. / REP.	PART NO. / N° RÉF.	DESCRIPTION	QTY. / QTÉ
24	23269	SPRING BELT TENSION CUTTING HEAD	1
25	67028	BOLT M6 X 16	1
26	23253	BELT GUARD FRONT	1
27	24170	ROLL PIN M8 X 24	1
28	23270	SPRING ANGLE ADJUSTMENT ARM	1
29	23230	HANDLE ANGLE ADJUSTMENT	1
30	25363	CUTTING HEAD BLADE SHIELD ASSEMBLY WITH BEARINGS & DECALS	1
31	25722	HANDLE ASSEMBLY	1
32	23244	BEARING 15.75 ID X 35 OD X 11	2
33	23232	BUSHING 15 ID X 20 OD	2
34	16400	NUT M8	1
35	26961	BOLT M8 X 35	1
36	25826	MANUAL BAG	1
37	24895	PARTS BAG	1

\*See engine IPB for ordering engine service parts

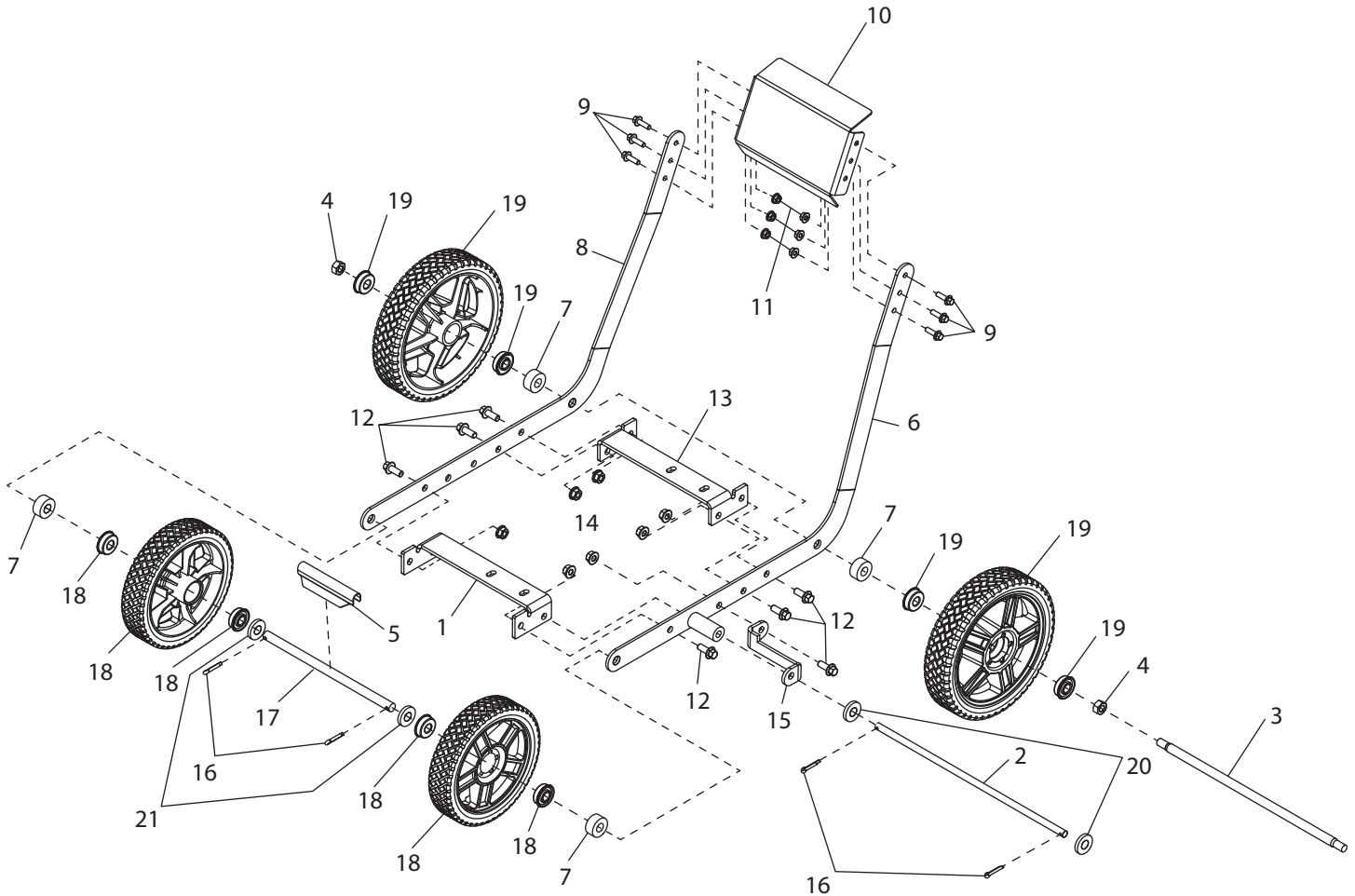
**ILLUSTRATED PARTS BREAKDOWN / ILLUSTRATION DES PIÈCES DÉTACHÉES - Chassis**

REF. / REP.	PART NO. / N° RÉF.	DESCRIPTION	QTY. / QTÉ
1	23252	MOUNT VIPER ENGINE FRONT	1
2	23233	ROD PIVOT	1
3	23808	AXLE REAR	1
4	W1265V0903	NUT M10	2
5	23254	SPACER WHEEL POSITION	1
6	24030	BAR LEFT SIDE	1
7	23266	SPACER AXLE	4
8	23249	BAR RIGHT SIDE	1
9	25058	BOLT M6 X 20	6
10	25580	PANEL DASH WITH DECALS	1
11	14109	NUT M6	6

REF. / REP.	PART NO. / N° RÉF.	DESCRIPTION	QTY. / QTÉ
12	19945	BOLT M8 X 20	7
13	23251	MOUNT VIPER ENGINE REAR	1
14	16400	NUT M8	7
15	23229	S BRACKET	1
16	22097	COTTER PIN 2 MM	4
17	23239	AXLE FRONT	1
18	23240	TIRE FRONT	2
19	23234	TIRE REAR	2
20	W1200126	WASHER M10	2
21	50175	WASHER M12	2

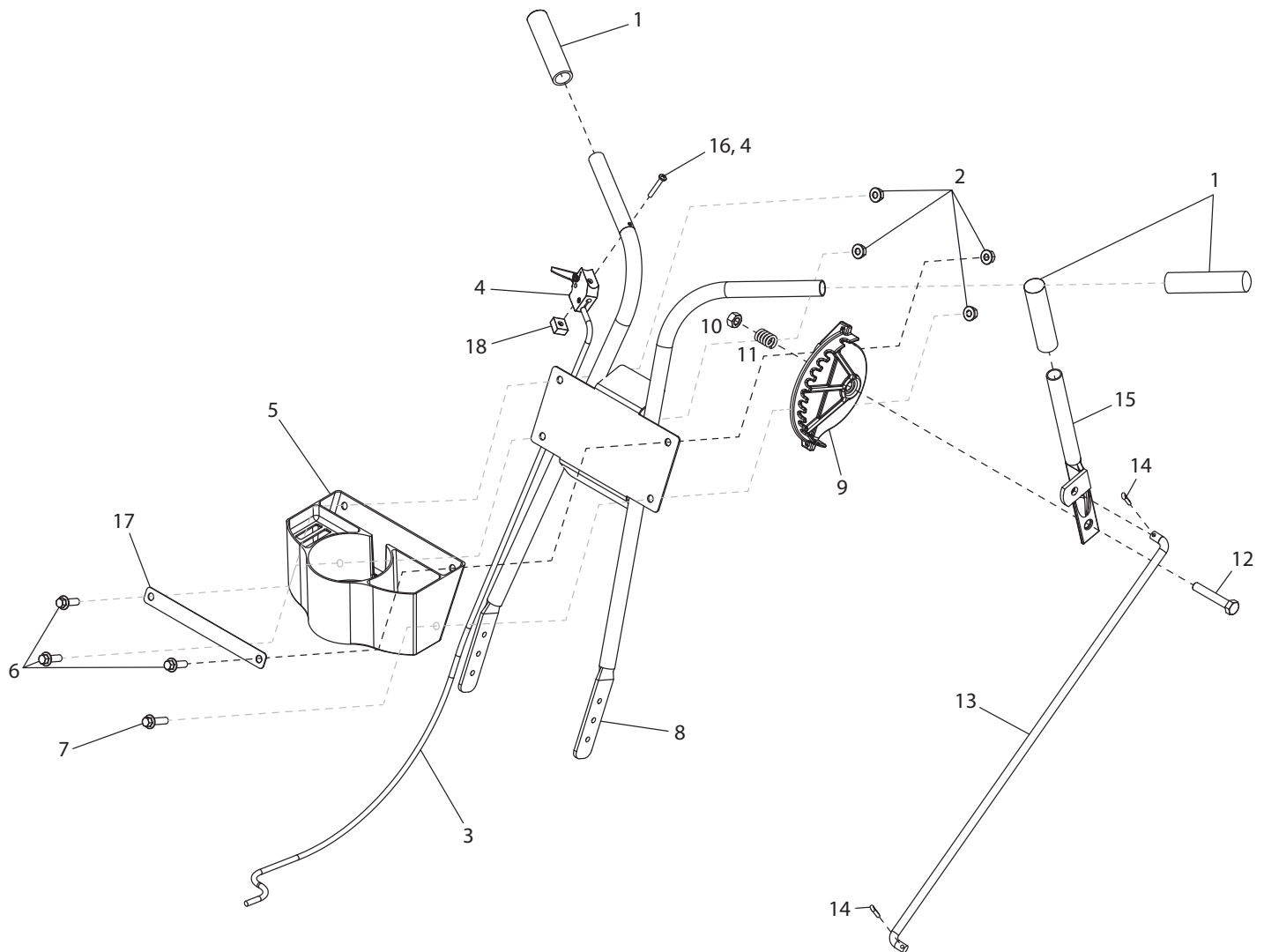
**ILLUSTRATED PARTS BREAKDOWN / ILLUSTRATION DES PIÈCES DÉTACHÉES - Handlebar**

REF. / REP.	PART NO. / N° RÉF.	DESCRIPTION	QTY. / QTÉ
1	23261	GRIP	3
2	16400	NUT M8	4
3	23245	THROTTLE CABLE	1
4	26771	TRIGGER	1
5	24769	CUP AND TOOL HOLDER	1
6	64617	BOLT M8 X 25	3
7	3244	BOLT M8 X 30	1
8	25712	HANDLE BAR WITH DECALS	1
9	23259	BRACKET HEIGHT ADJUSTER	1

REF. / REP.	PART NO. / N° RÉF.	DESCRIPTION	QTY. / QTÉ
10	W1265V0903	NUT M10	1
11	23268	SPRING FOR HEIGHT ADJUSTMENT	1
12	18844	BOLT M10 X 20	1
13	23260	ROD CONTROL	1
14	22097	COTTER PIN 2 MM	2
15	23246	HEIGHT SELECTOR	1
16	10888	BOLT M5 X 30	1
17	26930	STRAP TOOL & CUP HOLDER	1
18	17056	SQUARE NUT M5	1

**(OPTIONAL) EDGER CURB WHEEL KIT PARTS EXPLOSION AND LIST (24024)**

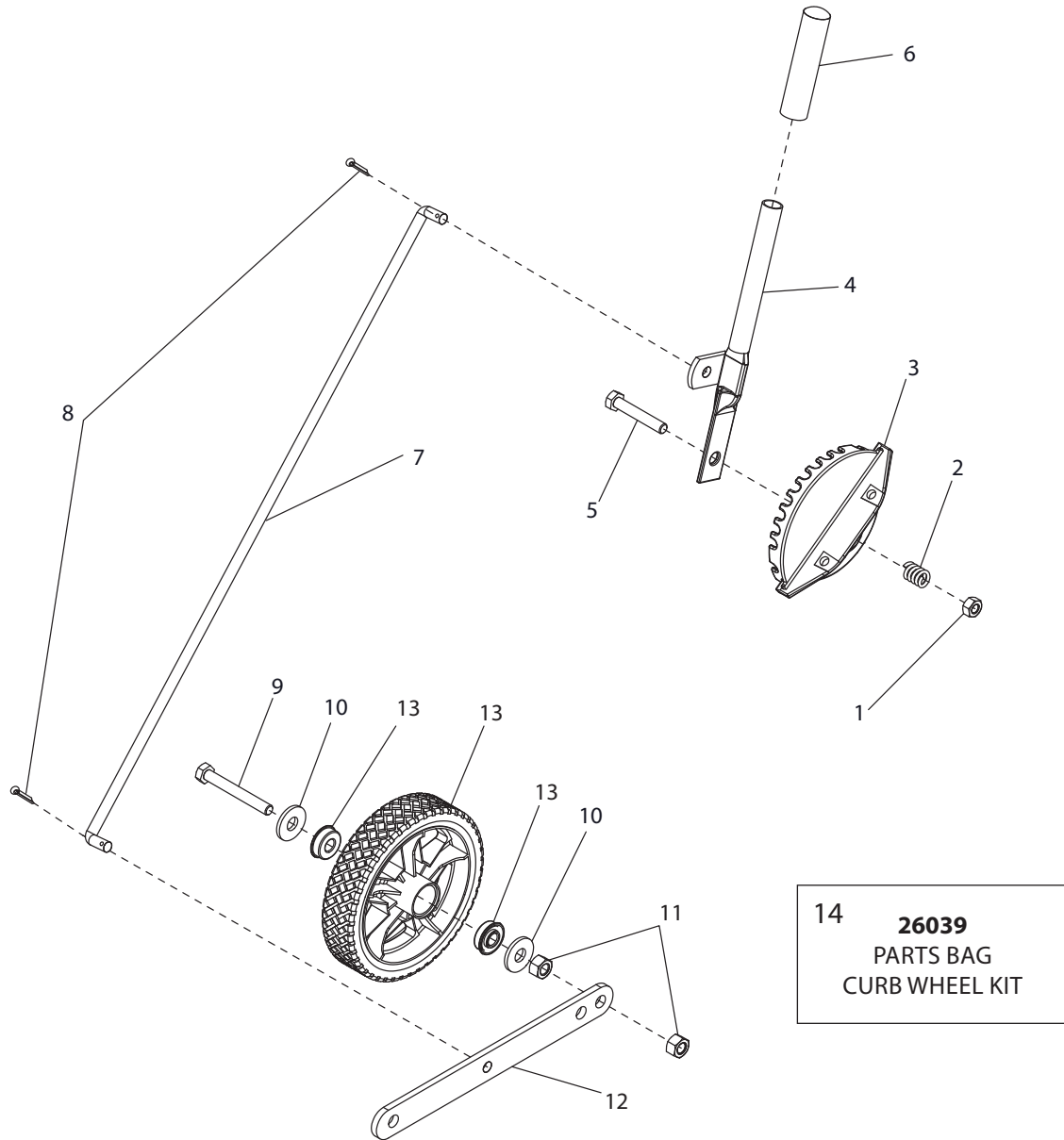

REF. / REP.	PART NO. / N° RÉF.	DESCRIPTION	QTY. / QTÉ
1	W1265V0903	NUT M10	1
2	23268	SPRING FOR HEIGHT ADJUST	1
3	23259	BRACKET HEIGHT ADJUSTER	1
4	23985	HANDLE WHEEL HEIGHT SELECTOR	1
5	18844	BOLT M10 X 20	1
6	23261	GRIP	1
7	23809	ROD CONTROL CURB WHEEL	1

REF. / REP.	PART NO. / N° RÉF.	DESCRIPTION	QTY. / QTÉ
8	22097	COTTER PIN 2 MM	2
9	25318	BOLT M12 X 80	1
10	50175	WASHER M12	2
11	25131	NUT M12	2
12	23984	LEG CURB WHEEL	1
13	23240	WHEEL WITH BEARINGS	1
14	26039	PARTS BAG CURB WHEEL KIT	1

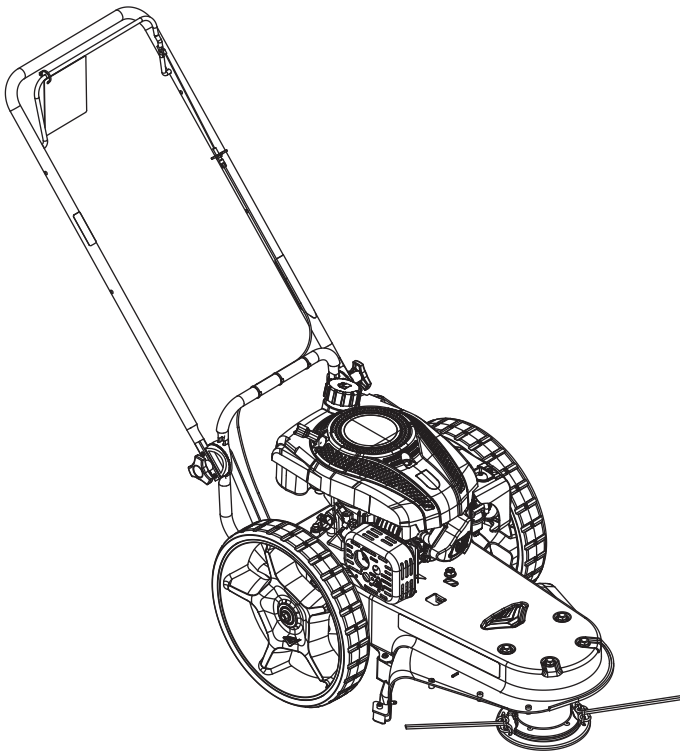

**YOU MAY ALSO BE  
INTERESTED IN...**

## Earthquake® Fields Edge™ **String Mower**

Powered by a strong yet quiet Viper® engine, the Fields Edge™ String Mower chops down your unsightly weeds and stubborn brush with ease. The large wheels allow you to float through thick grass, weeds, brush, nettles and other foliage too difficult for push mowers to overcome.

**YOU MAY ALSO BE  
INTERESTED IN...**

## Earthquake® Cultivator **Dethatcher Kit**

Attach the dethatcher kit to any Earthquake cultivator to dethatch your lawn and promote healthy growth.

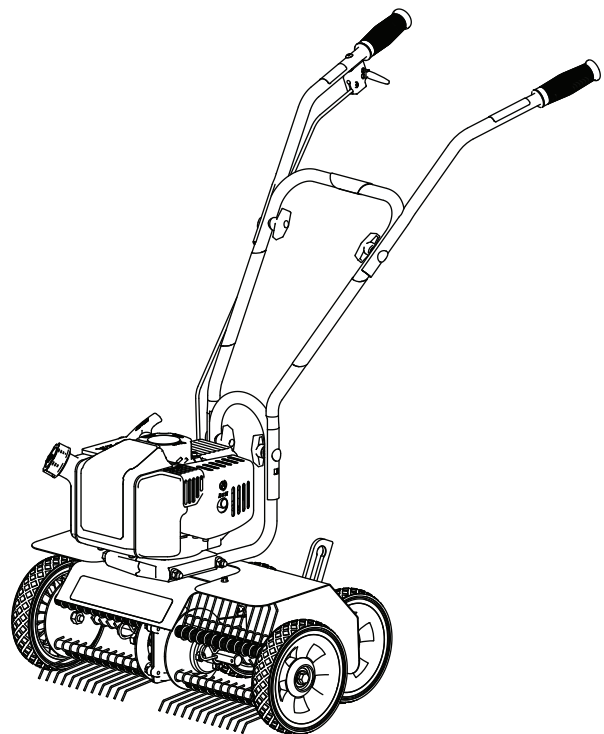



GROUNDBREAKING POWER EQUIPMENT

1160 Eighth Avenue  
PO Box 666  
Cumberland, WI 54829

Phone, Téléphone : (800) 345-6007  
Fax, Télécopieur : (715) 822-2124  
[www.getearthquake.com](http://www.getearthquake.com)