



DELUXE 6PC TRAMPOLINE ANCHOR KIT

MODEL# 9302DAK
PRODUCT MANUAL VERSION 1.21.01

FOR AGES:

N/A

TO BUILD:



TOOLS NEEDED:



HOW-TO
VIDEOS ONLINE



Manual en
español ubicado
en GQBrands.com

Spanish Manual located
at GQBrands.com

CUSTOMER SERVICE

GQBrands.com • CustomerService@GQBrands.com • 1-866-498-5269 • 4401 Samuell Blvd, Ste 150, Mesquite, TX 75149



PATENT PENDING*

CUSTOMER SERVICE INFORMATION

Thank you for purchasing: 6PC TRAMPOLINE ANCHOR KIT

MODEL# 9302DAK

If you have an issue with your item, do not return. Please report items that are damaged or missing parts to the manufacturer GQ Brands within three days of delivery. Contact customer service at customerservice@gqbrands.com to open a ticket.

At GQBrands®, we want all of our customers to be completely satisfied with their purchase. Take time to review the contents of the product you have just received to make sure that all of the parts are included. If you find that any parts are missing or damaged, we will provide replacement parts at no charge within 30 days of purchase. Please keep in mind that for select damaged part replacement requests, we will require a photo for submission.

To register your product please visit:
www.globalqualitybrands.com/product-registration
or scan code:



To order these parts, or if you have any other questions or concerns about this GQBrands product, please contact us at

PureFun.Net
GQBrands®
Phone: 1-866-498-5269
Email: CustomerService@GQBrands.com
4401 Samuell Blvd, Ste 150, Mesquite, TX 75149

Please be sure to include the following information when you contact Customer Service:

YOUR NAME: _____

YOUR MAILING ADDRESS: _____

YOUR EMAIL ADDRESS: _____

PRODUCT NAME: _____

PRODUCT MODEL#: _____

PART NUMBER _____

RETAILER WHERE PURCHASED: _____

DATE OF PURCHASE: _____

ORDER NUMBER: (If Available) _____

QUANTITY NEEDED: _____

SERIAL NUMBER: (On Product Frame)

LIMITED WARRANTY

Global Quality Brands® warrants this product to be free from defects in workmanship and materials under normal use and conditions for a period of **90 DAYS FROM THE DATE OF ORIGINAL PURCHASE**. This Limited Warranty is not transferable and is available only for the original purchaser of the Product. The Company's obligation under this warranty is limited to replacing or repairing the Product, at the discretion of the company.

All warranty coverage extends only to the original retail purchaser from the date of purchase. GQBrands obligation under this warranty is limited to replacing or repairing, at Global Quality Brands® option. All products for which a warranty claim is made must be received by Global Quality Brands® and accompanied by sufficient proof of purchase (photocopy of the original store receipt, indicating the date of purchase). All freight and handling fees are the responsibility of the consumer to pay, both to and from Global Quality Brands®. All warranty claims must be pre-authorized by Global Quality Brands® pre-authorization can be obtained by calling 866-498-5269.

This warranty does not cover ordinary wear and tear, weathering, failure to follow directions, improper installation, improper maintenance, or acts of nature, (such as damage caused by wind, lightning, snow, water, or ice) weather damage, damage caused by unauthorized repair work or damage caused by improper use of the products are not covered by the product warranty. No other warranty beyond that specifically set forth above is authorized by GQBrands®.

GLOBAL QUALITY BRANDS® IS NOT RESPONSIBLE OR LIABLE FOR INDIRECT, SPECIAL OR CONSEQUENTIAL DAMAGES ARISING OUT OF OR IN CONNECTION WITH THE USE OR PERFORMANCE OF THE PRODUCT OR OTHER DAMAGES WITH RESPECT TO ANY ECONOMIC LOSS, LOSS OF PROPERTY, LOSS OF REVENUE OR PROFITS, LOSS OF ENJOYMENT OR USE, COST OF REMOVAL, INSTALLATION OR OTHER CONSEQUENTIAL DAMAGES. SOME STATES DO NOT ALLOW THE EXCLUSION OR LIMITATION OF INCIDENTAL OR CONSEQUENTIAL DAMAGES. ACCORDINGLY,

THE ABOVE LIMITATION MAY NOT APPLY TO YOU. THE WARRANTY EXTENDED HEREUNDER IS IN LIEU OF ALL OTHER WARRANTIES AND GLOBAL QUALITY BRANDS®, SPECIFICALLY DISCLAIMS ANY IMPLIED WARRANTY OF MERCHANTABILITY OR FITNESS FOR A PARTICULAR PURPOSE IS LIMITED IN ITS SCOPE AND DURATION TO THE TERMS SET FORTH HEREIN. SOME STATES DO NOT ALLOW LIMITATION ON HOW LONG AN IMPLIED WARRANTY LASTS. ACCORDINGLY, THE ABOVE LIMITATION MAY NOT APPLY TO YOU. THIS WARRANTY GIVES YOU SPECIFIC LEGAL RIGHTS. YOU MAY ALSO HAVE OTHER RIGHTS, WHICH VARY FROM STATE TO STATE.

WHILE EVERY ATTEMPT IS MADE TO ENSURE THE HIGHEST DEGREE OF PROTECTION IN ALL EQUIPMENT, WE CANNOT GUARANTEE FREEDOM OF INJURY. THE USER ASSUMES ALL RISK OF INJURY DUE TO USE. ALL MERCHANDISE IS SOLD ON THIS CONDITION, WHICH NO REPRESENTATIVE OF GQBRANDS® CAN WAIVE OR CHANGE.

WARNINGS



ADULT ASSEMBLY REQUIRED **NOT** for children under 3 years of age.

Please read these warnings and the information in this manual in its entirety.

Failure to comply with the following instructions may increase the risk of serious injury and/or death:

- The 6PC Wind Stakes are only meant to assist in keeping your trampoline secure in low to moderate winds.
- If the soil under your trampoline is of insufficient consistency, or if you live in an area which experiences high winds and/or high wind gusts, Pure Fun recommends that you disassemble your trampoline and safely store it during severe weather.
- Using an anchor kit is not an insurance policy and will not add additional warranty benefits to your trampoline.
- ADULT ASSEMBLY REQUIRED
- The installation and use of this kit does not guarantee your trampoline will not be damaged by wind or other severe weather nor does it affect the trampoline warranty
- Do not install in mud, dry soil, sand, frozen or extremely rocky ground.
- Contact your local utility officials to make sure there are no underground utilities where you will be placing the anchor kit.
- Dispose of all packaging materials safely and per local ordinance.
- Anchors may protrude out of the ground. This kit must not be used on a trampoline without a safety enclosure net fitted. Falling off the trampoline onto an anchor could result in serious injury.
- We cannot guarantee freedom from injury. The user assumes all risks of injury due to use. All merchandise is sold on this condition, which no representative of the company can waive or change.

ASSEMBLY INSTRUCTIONS

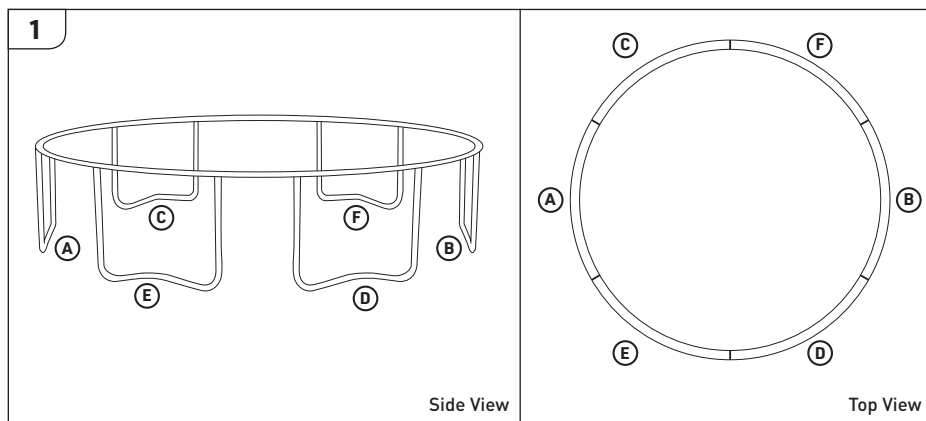

1. Locate all legs of the trampoline to install the wind stakes. In order to keep the trampoline properly grounded you must place stakes evenly distributed around the trampoline as pictured to the right.

EXAMPLE:

Locate Letters A, B, C, D, E, & F on the image shown as an example of where the Wind Stakes can properly be attached.

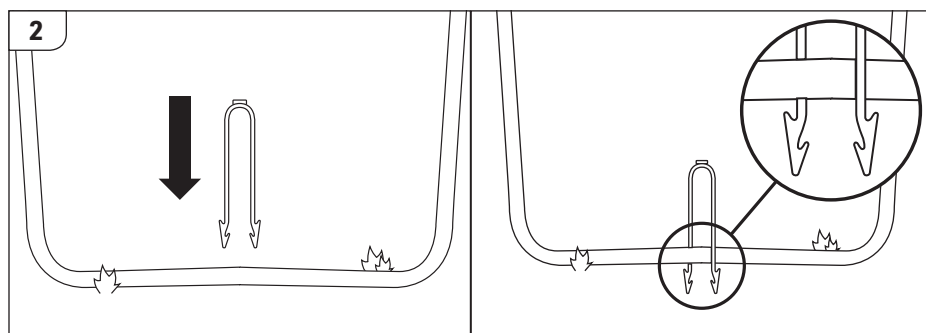

2. To install the Wind Stakes, locate the middle of the U-Shaped Leg and point the legs of the Stakes towards the ground.

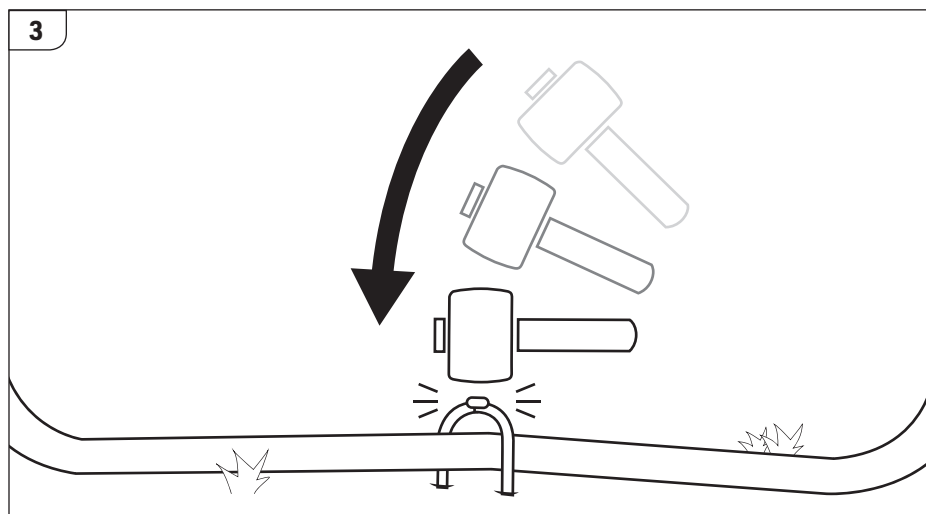

3. Using a rubber mallet, hammer the Stake into the ground by hitting the upper knob of the Wind Stake. Do this until the arch is touching the leg of the U-Shaped Leg.

NOTE:

Do not use any tool other than a rubber mallet to hammer the Wind Stake into the ground, failure to do this will break or crack the product.

4. Repeat Steps 1-3 until all Wind Stakes have been successfully secured into their respective U-Shaped Legs of the Trampoline.

FREQUENTLY ASKED QUESTIONS

Question: "One of my pieces is missing" or "A part is damaged, how do I replace it?"

Answer: If you are still within your warranty period (90 days from initial purchase) You should contact customer service. You can also purchase select replacement parts at: www.purefun.net

Question: "I had a part missing from my box" or "something was damaged during assembly, can you send it to me?"

Answer: If it has been 30 days or less from the date of your initial purchase, you can contact customer service for a replacement part to be issued.

Question: "Will this hold the trampoline down during a hurricane or storm season?"

Answer: No. We suggest you take your entire trampoline apart and store it during storm or hurricane season or during the event of known bad weather

Thank You Coupon!

As a way of saying thank you for purchasing one of our products, here is a 10% OFF coupon for your next purchase at

www.PureFun.net

Use Code: GQBRANDS10 at Checkout