

Operating Instructions & Parts Manual



Model 9682080



**8"
Variable Speed
Bench Grinder**



GETTING STARTED

Please read and save these instructions. Read carefully before attempting to assemble, install, operate or maintain the product described.

Protect yourself and others by observing all safety information. Failure to comply with instructions could result in personal injury and/or property damage! retain instructions for future reference.

SAFETY / SPECIFICATIONS

ASSEMBLY / INSTALLATION

OPERATION

TROUBLESHOOTING

MAINTENANCE / REPAIR

Model #: _____

Serial #: _____

Purchase Date: _____



GETTING STARTED

Structural Requirements

Make sure all supporting structures and load attaching devices are strong enough to hold your intended loads. If in doubt, consult a qualified structural engineer.

Electrical Requirements

⚠ WARNING *To avoid electrical shock to yourself and damage to the Bench Grinder, use proper circuit protection.*

The Bench Grinder is factory wired for 120V, 60 Hz, operation. Connect to a 120V, 15 amp branch circuit and use a 15 amp time delay fuse or circuit breaker. The electrical circuit cannot have any wire size less than #14. To avoid shock or fire, replace power cord immediately if it is damaged in any way.

Tools Needed:

Standard mechanic's hand tool set.

UNPACKING

Carton should be handled with care to avoid damage from dropping, bumping, etc. Store and unpack carton with correct side up. After unpacking Bench Grinder, inspect carefully for any damage that may have occurred during transit. Check for loose, missing or damaged parts. If any damage or loss has occurred, claim must be filed with carrier immediately. Check for completeness. Immediately report missing parts to dealer.

⚠ WARNING *If any parts are missing, do not attempt to plug in the power cord and turn "ON" the Bench Grinder. The Bench Grinder can only be turned "ON" after all the parts have been obtained and installed correctly.*

This Bench Grinder will require a minimal amount of assembly.

Remove any protective materials and coatings from all of the parts and the bench grinder. The protective coatings can be removed by spraying WD-40 on them and wiping it off with a soft cloth. This may need to be redone several times before all of the protective coatings are removed completely.

⚠ CAUTION *DO NOT use acetone, gasoline or lacquer thinner to remove any protective coatings.*

Contents:

Refer to Figure 1

- Grinder (not shown) (1)
- B. Eyeshield assembly (2)
- C. Carriage head screw M6 x 12mm (2)
- D. Hex head screw, M5 x 10 (4)
- E. Flat washer M5 (4)
- F. Lock washer M5 (4)
- G. Wheel dresser (1)
- H. Hex head screw M8 x 12mm (4)
- I. Flat washer M8 (4)
- J. Spark arrestor, left (1)
- K. Spark arrestor, right (1)
- L. Flat washer M6 (4)

- M. Eyeshield knob (2)
- N. Tool rest support, left (1)
- O. Tool rest support, right (1)
- P. Tool rest, right (1)
- Q. Drill bit sharpening plate (1)
- R. Tool rest knob (2)
- S. Spacer for wire wheel (1)
- T. Tool rest, left (1)
- U. Special wrench (1)
- Quench tray (not shown) (1)
- W. Lock Washer M6 (2)
- Operating Instructions and Parts Manual (Not Shown) (1)

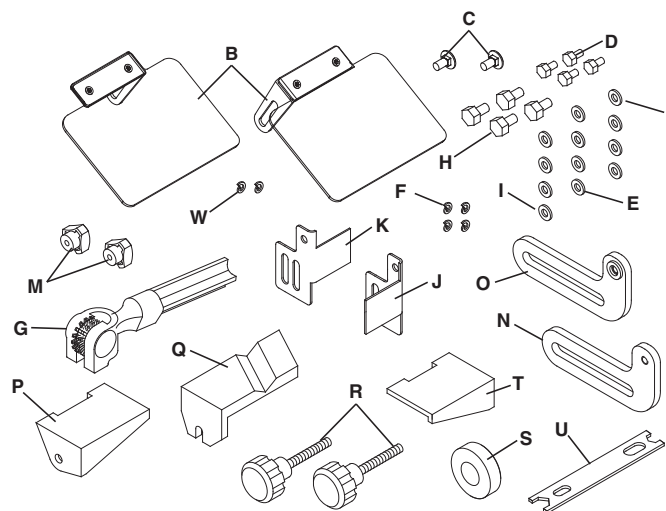

Figure 1 - Contents

Unpack:

- Do not discard packing materials until after machine has been inspected for damage and completeness. Locate loose parts and set aside.

Inspect:

- After unpacking the unit, carefully inspect for any damage that may have occurred during transit. Check for loose, missing or damaged parts. Shipping damage claims must be filed with the carrier.
- All tools should be visually inspected before use, in addition to regular periodic maintenance inspections.
- Be sure that the voltage labeled on the unit matches your power supply.

SAFETY RULES

General Safety Instructions

Operating a Bench Grinder can be dangerous if safety and common sense are ignored. The operator must be familiar with the operation of the tool. Read this manual to understand this Bench Grinder. DO NOT operate this Bench Grinder if you do not fully understand the limitations of this tool. DO NOT modify this Bench Grinder in any way.

**SAFETY RULES (CONTINUED)**

▲ WARNING *For your own safety, read all of the instructions and precautions before operating tool.*



PROPOSITION 65 WARNING: Some dust created by using power tools contain chemicals known to the state of California to cause cancer, birth defects or other reproductive harm.

Some examples of these chemicals are:

- Lead from lead-based paints.
- Crystalline silica from bricks and cement and other masonry products.
- Arsenic and chromium from chemically-treated lumber.

Your risk from these exposures varies, depending on how often you do this type of work. To reduce your exposure to these chemicals: work in a well ventilated area and work with approved safety equipment. Always wear **OSHA/NIOSH** approved, properly fitting face mask or respirator when using such tools.

▲ WARNING *Always follow proper operating procedures as defined in this manual even if you are familiar with the use of this or similar tools. Remember that being careless for even a fraction of a second can result in severe personal injury.*

- READ the entire Owner's Manual. LEARN how to use the tool for its intended applications.
- GROUND ALL TOOLS. If the tool is supplied with a 3-prong plug, it must be plugged into a 3-contact electrical receptacle. The 3rd prong is used to ground the tool and provide protection against accidental electric shock. DO NOT remove the 3rd prong. See Grounding Instructions on page 8 and 9.
- AVOID A DANGEROUS WORKING ENVIRONMENT. DO NOT use electrical tools in a damp environment or expose them to rain.
- DO NOT use electrical tools in the presence of flammable liquids or gasses.
- ALWAYS keep the work area clean, well lit, and organized. DO NOT work in an environment with floor surfaces that are slippery from debris, grease, and wax.
- KEEP VISITORS AND CHILDREN AWAY. DO NOT permit people to be in the immediate work area, especially when the electrical tool is operating.
- DO NOT FORCE THE TOOL to perform an operation for which it was not designed. It will do a safer and higher quality job by only performing operations for which the tool was intended.
- WEAR PROPER CLOTHING. DO NOT wear loose clothing, gloves, neckties, or jewelry. These items can get caught in the machine during operations and pull the operator into the moving parts. The user must wear a protective cover on their hair, if the hair is long, to prevent it from contacting any moving parts.
- CHILDPROOF THE WORKSHOP AREA by removing switch keys, unplugging tools from the electrical receptacles, and using padlocks.

- DO NOT use electrical tools in the presence of flammable liquids or gasses.
- ALWAYS UNPLUG THE TOOL FROM THE ELECTRICAL RECEPTACLE when making adjustments, changing parts or performing any maintenance.
- KEEP PROTECTIVE GUARDS IN PLACE AND IN WORKING ORDER.
- AVOID ACCIDENTAL STARTING. Make sure that the power switch is in the "OFF" position before plugging in the power cord to the electrical receptacle.
- REMOVE ALL MAINTENANCE TOOLS from the immediate area prior to turning "ON" the Bench Grinder.
- USE ONLY RECOMMENDED ACCESSORIES. Use of incorrect or improper accessories could cause serious injury to the operator and cause damage to the tool. If in doubt, check the instruction manual that comes with that particular accessory.
- NEVER LEAVE A RUNNING TOOL UNATTENDED. Turn the power switch to the "OFF" position. DO NOT leave the tool until it has come to a complete stop.
- DO NOT STAND ON A TOOL. Serious injury could result if the tool tips over or you accidentally contact the tool.
- DO NOT store anything above or near the tool where anyone might try to stand on the tool to reach it.
- MAINTAIN YOUR BALANCE. DO NOT extend yourself over the tool. Wear oil resistant rubber soled shoes. Keep floor clear of debris, grease, and wax.
- MAINTAIN TOOLS WITH CARE. Always keep tools clean and in good working order. Keep all blades and tool bits sharp.
- EACH AND EVERY TIME, CHECK FOR DAMAGED PARTS PRIOR TO USING THE TOOL. Carefully check all guards to see that they operate properly, are not damaged, and perform their intended functions. Check for alignment, binding or breaking of moving parts. A guard or other part that is damaged should be immediately repaired or replaced.
- CHILDPROOF THE WORKSHOP AREA by removing switch keys, unplugging tools from the electrical receptacles, and using padlocks.
- DO NOT OPERATE TOOL IF UNDER THE INFLUENCE OF DRUGS OR ALCOHOL.
- SECURE ALL WORK. Use clamps or jigs to secure the workpiece. This is safer than attempting to hold the workpiece with your hands.
- STAY ALERT, WATCH WHAT YOU ARE DOING, AND USE COMMON SENSE WHEN OPERATING A POWER TOOL. DO NOT USE A TOOL WHILE TIRED OR UNDER THE INFLUENCE OF DRUGS, ALCOHOL, OR MEDICATION. A moment of inattention while operating power tools may result in serious personal injury.



SAFETY RULES (CONTINUED)

- ALWAYS WEAR A DUST MASK TO PREVENT INHALING DANGEROUS DUST OR AIRBORNE PARTICLES, including wood dust, crystalline silica dust and asbestos dust. Direct particles away from face and body. Always operate tool in well ventilated area and provide for proper dust removal. Use dust collection system wherever possible. Exposure to the dust may cause serious and permanent respiratory or other injury, including silicosis (a serious lung disease), cancer, and death. Avoid breathing the dust, and avoid prolonged contact with dust. Allowing dust to get into your mouth or eyes, or lay on your skin may promote absorption of harmful material. Always use properly fitting **NIOSH/OSHA** approved respiratory protection appropriate for the dust exposure, and wash exposed areas with soap and water.
- USE A PROPER EXTENSION CORD IN GOOD CONDITION. When using an extension cord, be sure to use one heavy enough to carry the current your product will draw. The table at right shows the correct size to use depending on cord length and nameplate amperage rating. If in doubt, use the next heavier gauge. The smaller the gauge number, the larger diameter of the extension cord. If in doubt of the proper size of an extension cord, use a shorter and thicker cord. An undersized cord will cause a drop in line voltage resulting in a loss of power and overheating. **USE ONLY A 3-WIRE EXTENSION CORD THAT HAS A 3-PRONG GROUNDING PLUG AND A 3-POLE RECEPTACLE THAT ACCEPTS THE TOOL'S PLUG.**
- USE A PROPER EXTENSION CORD IN GOOD CONDITION. When using an extension cord, be sure to use one heavy enough to carry the current your product will draw. The table at right shows the correct size to use depending on cord length and nameplate amperage rating. If in doubt, use the next heavier gauge. The smaller the gauge number, the larger diameter of the extension cord. If in doubt of the proper size of an extension cord, use a shorter and thicker cord. An undersized cord will cause a drop in line voltage resulting in a loss of power and overheating. **USE ONLY A 3-WIRE EXTENSION CORD THAT HAS A 3-PRONG GROUNDING PLUG AND A 3-POLE RECEPTACLE THAT ACCEPTS THE TOOL'S PLUG.**

Specific Safety Instructions for Bench Grinders

The operation of any grinder can result in debris being thrown into your eyes, which can result in severe eye damage. **ALWAYS WEAR EYE PROTECTION.** Any power tool can throw debris during operations, which could cause severe and permanent eye damage. Everyday eyeglasses are **NOT** safety glasses. **ALWAYS** wear Safety Goggles (that comply with ANSI standard Z87.1) when operating power tools.

Basic precautions should always be followed when using your Bench Grinder. To reduce the risk of injury, electrical shock, or fire, comply with the safety rules listed below:

- ALWAYS USE THE EYE SHIELDS AND WHEEL GUARDS provided with the grinder.

- REPLACE A CRACKED OR DAMAGED GRINDING WHEEL IMMEDIATELY. A damaged wheel can discharge debris at a high velocity towards the operator. Carefully handle the grinding wheels since they are abrasive. Prior to replacing a grinding wheel, check it for cracks. **DO NOT** remove the blotter or label on both sides of the grinding wheel. Tighten the spindle nut just enough to hold the grinding wheel firmly to the Bench Grinder. Do not over-tighten the nut. Excessive clamping force can damage the grinding wheel. Only use the wheel flanges provided with the grinder. When selecting a replacement grinding wheel, verify that the grinding wheel has a higher R.P.M. rating than the maximum R.P.M. of the Bench Grinder.
- THE DIAMETER OF THE GRINDING WHEELS WILL DECREASE WITH USE. Adjust the tool rests and spark arrestors to maintain a distance of 1/16" from the wheel.
- DO NOT STAND IN FRONT OF THE BENCH GRINDER WHEN STARTING IT. Stand to one side of the Bench Grinder and turn it "ON". Wait at the side for one minute until the grinder comes up to full speed. There is always a possibility that debris from a damaged grinding wheel may be discharged towards the operator.
- THE BENCH GRINDER WILL PRODUCE SPARKS AND DEBRIS DURING GRINDING OPERATIONS. Be sure that there are not any flammable materials in the vicinity. Frequently clean grinding dust from the back of the Bench Grinder.
- NEVER FORCE THE WORKPIECE AGAINST A GRINDING WHEEL, especially if the wheel is cold. Apply the workpiece slowly, allowing the grinding wheel an opportunity to warm up. This will minimize the chance of wheel breakage. **DO NOT** grind using the sides of the grinding wheels. **DO NOT** apply coolant directly to the grinding wheel.
- KEEP ALL WHEEL GUARDS IN PLACE. **DO NOT** USE THE BENCH GRINDER WITH THE WHEEL GUARDS REMOVED.
- KEEP THE TOOL RESTS FIRMLY TIGHTENED.
- ALWAYS USE THE SUPPLIED WHEEL DRESSER TO RESURFACE THE FACE OF THE GRINDING WHEEL.
- REMOVE ADJUSTING KEYS AND WRENCHES. Form habit of checking to see that keys and adjusting wrenches are removed from tool before turning it on.
- DIRECTION OF FEED. Feed work into a blade or cutter against the direction of rotation of the blade or cutter only.
- USE RIGHT TOOL. Don't force tool or attachment to do a job for which it was not designed.
- DO NOT overtighten wheel nut.
- ONLY use flanges furnished with the grinder.
- FREQUENTLY clean grinding dust from beneath grinder.
- DO NOT FORCE THE TOOL to perform an operation for which it was not designed. It will do a safer and higher quality job by only performing operations for which the tool was intended.
- SAVE THESE INSTRUCTIONS. Refer to them frequently and use them to instruct others.



SPECIFICATIONS

Know Your Bench Grinder

Refer to Figure 2.

1. INNER WHEEL GUARD - Covers the grinding wheels and protects against accidental contact.
2. WHEEL DRESSER - Used to clean and smooth front surface of the grinding wheels.
3. FLEXIBLE WORK LIGHT - Provides light to the operator during set up or grinding operations.
4. SPARK ARRESTOR - Prevents hot sparks and debris from contacting the operator.
5. QUICK RELEASE KNOB - Remove knobs to allow the Wheel Cover to be removed.
6. WHEEL COVER - Covers the grinding wheels and provides quick access for routine maintenance.
7. GRINDING WHEEL 60 GRIT - Used to remove light material from workpiece.
8. TOOL RESTS - Used to support the workpiece that is being ground. Adjustable to provide angled surfaces.
9. DRILL BIT SHARPENING PLATE - Used to sharpen twist drill bits. Should be removed for regular grinding operations.
10. ON/OFF SWITCH - Used to turn ON and turn OFF the grinder.
11. VARIABLE SPEED SWITCH - Permits adjusting rotational speed of the grinding wheel.
12. QUENCH TRAY - Used to cool workpiece after grinding.
13. TOOL REST ADJUSTABLE SUPPORTS - Lets the operator position the tool rest closer to the wheel as the wheel decreases in diameter due to wear.
14. 8" WIRE WHEEL - Used to remove rust and dirt from workpiece.
15. EYESHIELD - Protective Lexan see-thru shields to prevent any loose debris from contacting the operator.
16. GRINDING WHEEL IDENTIFICATION LABEL - Provides information on wheel size, grit and maximum rpm.
17. FLANGES - used to secure the grinding wheels to the grinder and distribute the load of the Lock Nuts.
18. ARBOR HEX NUT - Used to secure the grinding wheels to the grinder.
19. SPACER (not shown) - Used to align the wire wheel or buffing wheel into the center of the tool rest.

SPECIFICATIONS

9682080 8" Variable Speed Bench Grinder

Motor	Continuous duty 1/2 HP, 120 V, 5 A, 60 Hz, 2000–3400 RPM (speed rating)
Grinding wheel size	8" x 1", 5/8" bore
Grinding wheel grit	60
Lamp	120V, 40 watt or less bulb type R20, medium base or equivalent (not included)
Tool rests	Left and Right
Eye shield assemblies	Clear Lexan Left and Right
Spark arrestors	Left and Right
Quench tray	6" x 2" x 2"

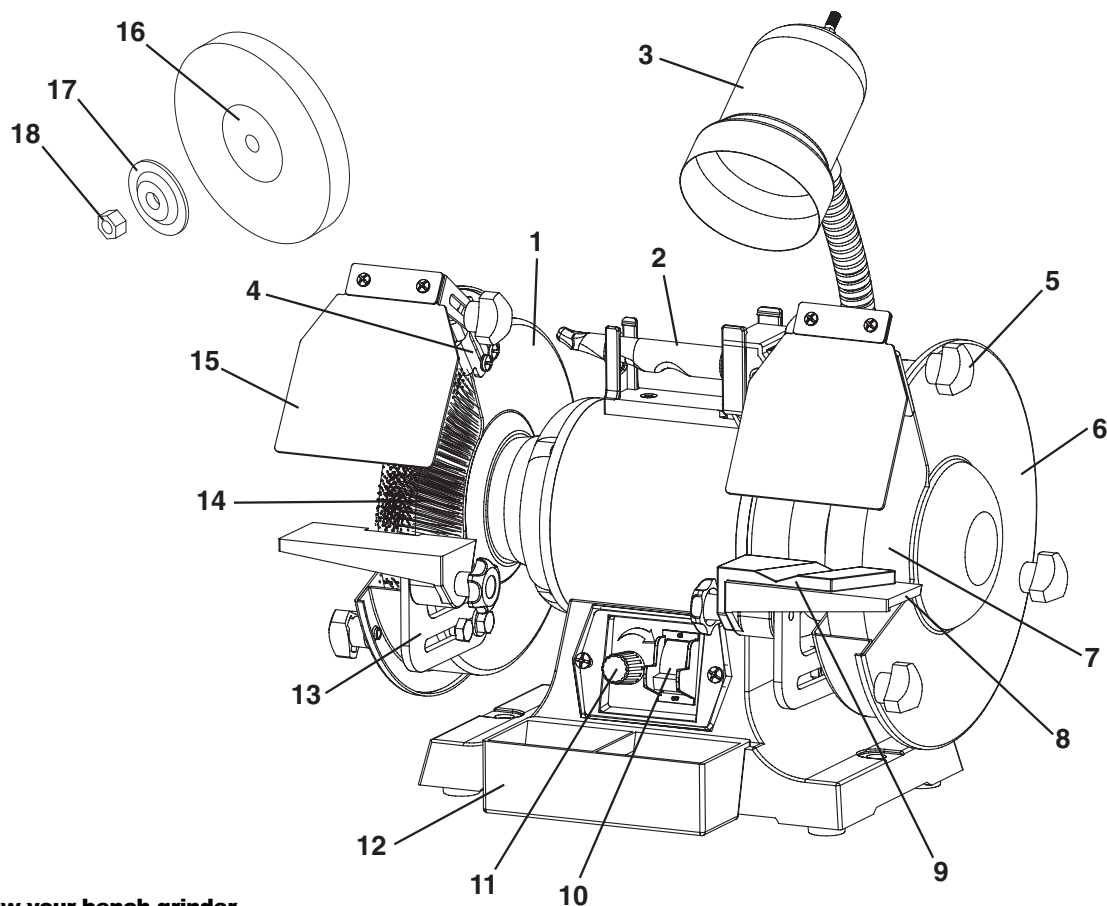

Figure 2 - Know your bench grinder.



ASSEMBLY

The Bench Grinder is provided with a left and right two piece tool rest. Both tool rests have a flat, smooth surface to lay your workpiece against. An accessory drill bit sharpening plate is included. This plate goes on over the right tool rest only and is used to sharpen twist drill bits.

⚠ WARNING *DO NOT assemble the Bench Grinder until you are sure the tool IS NOT plugged in.*

DO NOT assemble the Bench Grinder until you are sure the power switch is in the "OFF" position.

DO NOT assemble the Bench Grinder until you are sure the grinding wheels are firmly tightened to the Bench Grinder.

Tool Rests

The Bench Grinder is provided with two different tool rests assemblies. The left side tool rest is entirely flat. The right side tool rest is also flat.

1. Assemble the tool rest supports (A) to the inside surface of the wheel covers (B) with the flat washers (C) and hex head screws (D) as shown. See Figure 3.

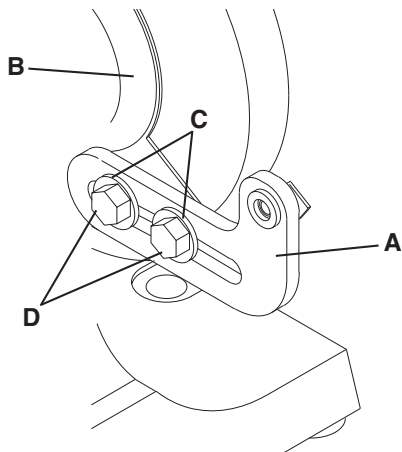

Figure 3 - Assemble tool rest supports.

2. Assemble the tool rests (E) to the supports (F) with the flat washers (G) and adjustment knobs (H) as shown. See Figure 4.

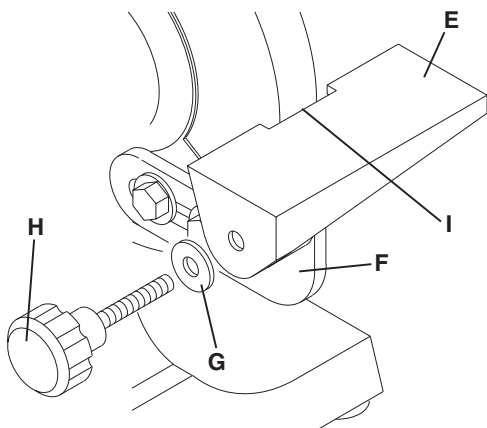

Figure 4 - Assemble tool rests to supports

3. Adjust each tool rest until its inside edge (I) is 1/16" from the grinding wheel. Firmly tighten the hex head screws holding the supports. See Figure 4.
4. Install the drill bit sharpening plate by loosening the right side adjustment knob until there is approximately a 1/4" of threads visible. Place the plate onto the right side tool rest and over the visible threads. The flat washer must be placed between the plate and the adjustment knob. Tighten the adjustment knob. See Figure 5.

IMPORTANT: The drill bit sharpening plate should ONLY be used when sharpening twist drill bits.

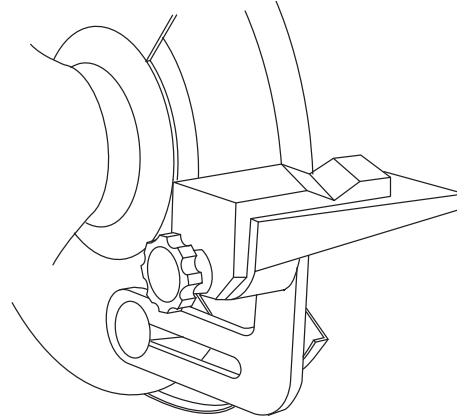

Figure 5 - Install the drill bit sharpening plate.

Spark Arrestors

1. Assemble the spark arrestors (A) to the inside surface of the wheel covers (B) with the hex head screws with washers (C) as shown. See Figure 6.
2. Adjust each spark arrestor until the lower edge (E) is 1/16" from the grinding wheel. Firmly tighten the hex head screws. See Figure 6.

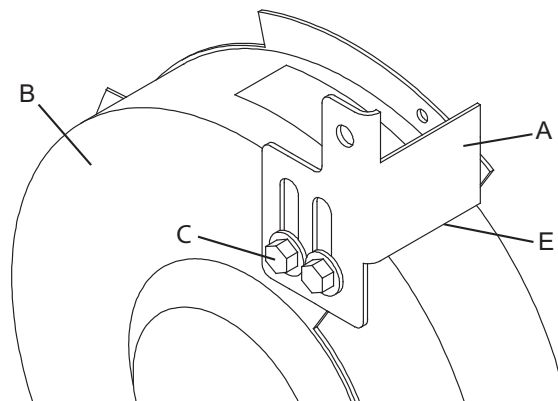
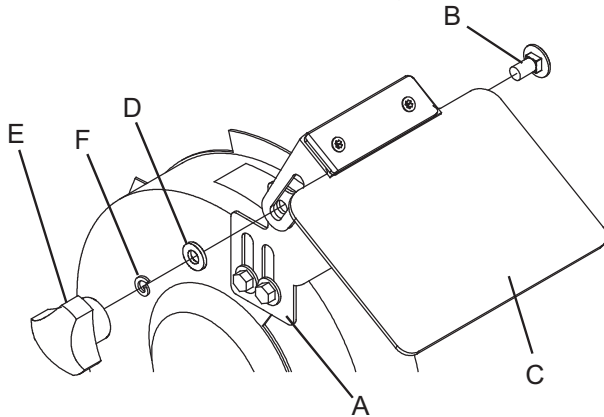

Figure 6 - Assemble spark arrestors.

**ASSEMBLY (CONTINUED)****Eyeshields**

1. Assemble the eyeshield (C) to the spark arrestor (A) inserting carriage head screw (B) through eyeshield and the spark arrestor as shown. See Figure 7.
2. Assemble the flat washer (D), lockwasher (F) and lock knob (E) to the carriage head screw and tighten until the eyeshield remains in the desired position. See Figure 7.

**Figure 7 - Eyeshields****Work Light**

The Bench Grinder is provided with a flexible work light to assist in visibility of the workpiece.

The Bench Grinder is NOT provided with a light bulb for the flexible work light.

▲ WARNING *To reduce the risk of fire, use a 120 volt, 40 Watt or less track light bulb, Type R20, medium base or equivalent (not included). DO NOT use a light bulb that extends past the end of the light housing.*

The flexible work light may be turned "ON" or "OFF" by using the rotary switch (B) on the top surface of the housing (A). The switch can be rotated in the clockwise direction only. See Figure 8.

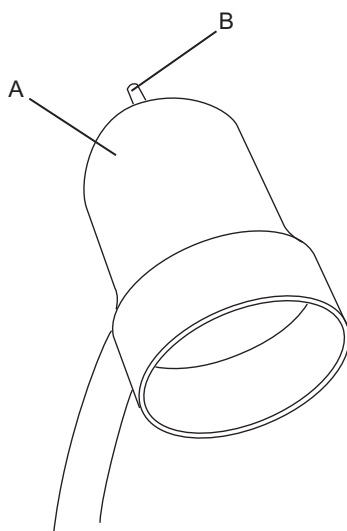
**Figure 8 - Work light ON/OFF switch and housing.**

NOTE: The flexible work light can be turned "ON" or "OFF" even if the Bench Grinder is turned "OFF".

▲ CAUTION *The Flexible Work Light housing will remain hot for a few minutes after turning it "OFF". Avoid contact with housing until it is cool.*

Permanent Mounting

Use the mounting pads on the base of the grinder to firmly attach grinder to a solid work surface (hardware not included). See Figure 9.

▲ WARNING *To avoid serious injury, secure the Bench Grinder to a solid work surface. If the Bench Grinder is not securely mounted, it will have the ability to move or tip over during grinding operations and possibly cause the operator's fingers to contact the grinding wheels.*

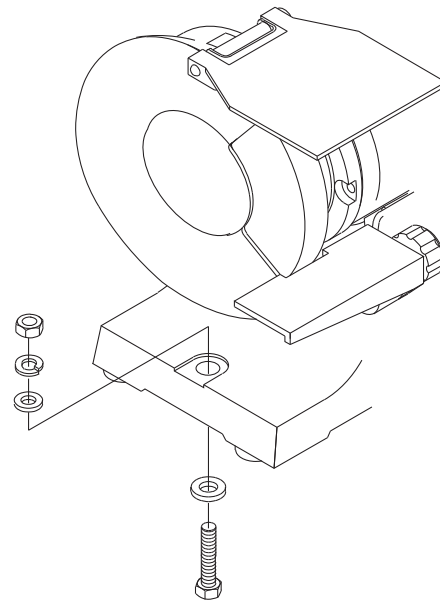
**Figure 9 - Permanent Mounting****INSTALLATION**

▲ WARNING *If any parts are missing, do not attempt to plug in the power cord and turn "ON" the Bench Grinder. The Bench Grinder can only be turned "ON" after all the parts have been obtained and installed correctly.*

Extension Cord Length and Gauge

120 volt operation only.

Amps	25' Cord Length	50' Cord Length
0 to 6 Amps	18 AWG	16 AWG
6 to 10 Amps	18 AWG	16 AWG
10 to 12 Amps	16 AWG	16 AWG





INSTALLATION (CONTINUED)

Grounding Instructions

Refer to Figures 10 and 11.

THIS TOOL MUST BE GROUNDED WHILE IN USE TO PROTECT THE OPERATOR FROM ELECTRIC SHOCK.

IN THE EVENT OF A MALFUNCTION OR BREAKDOWN, grounding provides the path of least resistance for electric current and reduces the risk of electric shock. This tool is equipped with an electric cord that has an equipment grounding conductor and a grounding plug. The plug **MUST** be plugged into a matching electrical receptacle that is properly installed and grounded in accordance with ALL local codes and ordinances.

DO NOT MODIFY THE PLUG PROVIDED. If it will not fit the electrical receptacle, have the proper electrical receptacle installed by a qualified electrician.

IMPROPER ELECTRICAL CONNECTION of the equipment grounding conductor can result in risk of electric shock. The conductor with the green insulation (with or without yellow stripes) is the equipment grounding conductor. DO NOT connect the equipment grounding conductor to a live terminal if repair or replacement of the electric cord or plug is necessary.

CHECK with a qualified electrician or service personnel if you do not completely understand the grounding instructions, or if you are not sure the tool is properly grounded.

USE ONLY A 3-WIRE EXTENSION CORD THAT HAS A 3-PRONG GROUNDING PLUG AND A 3-POLE RECEPTACLE THAT ACCEPTS THE TOOL'S PLUG.

REPLACE A DAMAGED OR WORN CORD IMMEDIATELY.

This tool is intended for use on a circuit that has an electrical receptacle as shown in Figure 10. Figure 10 shows a 3-wire electrical plug and electrical receptacle that has a grounding conductor.

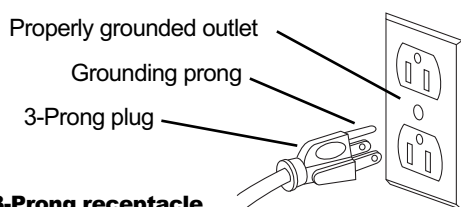

Figure 10 – 3-Prong receptacle

If a properly grounded electrical receptacle is not available, an adapter as shown in Figure 11 can be used to temporarily connect this plug to a 2-contact ungrounded receptacle.

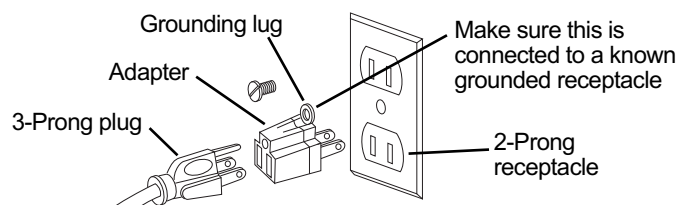

Figure 11 – 2-Prong receptacle with adapter

The adapter has a rigid lug extending from it that **MUST** be connected to a permanent earth ground, such as a properly grounded receptacle box. **THIS ADAPTER IS PROHIBITED IN CANADA.**

⚠ CAUTION *In all cases, make certain the electrical receptacle in question is properly grounded. If you are not sure have a certified electrician check the electrical receptacle.*

⚠ WARNING *This Bench Grinder is for indoor use only. To avoid serious injury, do not expose to rain or use in damp locations.*

OPERATION

The Bench Grinder is designed for hand held grinding, sharpening, and cleaning operations.

⚠ WARNING *ALWAYS WEAR EYE PROTECTION! Hot sparks are produced during grinding operations.*

GRINDING SPEED CHART

<i>Low Speed 2000 RPM Light Duty Operations</i>	<i>High Speed 3400 RPM Heavy Duty/Normal Operations</i>
Light Grinding	Heavy grinding
Sharpening	Stock Removal
Rust and paint removal	Deburring
Lowered grinding temperature	Buffing

Sharpening and removal of metal can be done on the right side of the Bench Grinder using the grinding wheel. Cleaning of metal surfaces can be done using the wire wheel on the left side of the Bench Grinder.

1. The power switch must be in the "OFF" position (see Figure 12) and the variable speed switch must be turned to its slowest setting by being turned all the way to the left until solid resistance is felt.

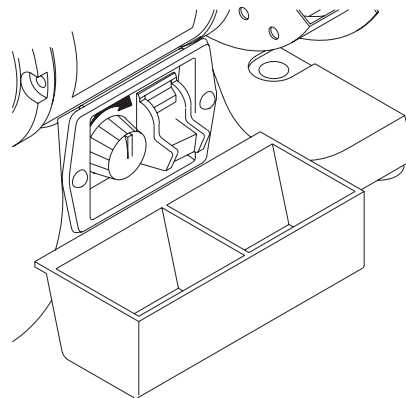

Figure 12

2. Stand to the side of the Bench Grinder and plug in the power cord to a suitable power source.
3. Remain to the side of the Bench Grinder and turn it "ON" by pressing switch at the ON position.
4. Allow the grinding wheels to come up to a steady speed for at least one minute. The RPMs of the Bench Grinder can be now increased to the desired speed for the particular grinding operation by rotating the variable speed switch clockwise.
5. The flexible work light may be turned "ON" if desired.





OPERATION (CONTINUED)

- Adjust the eyeshields. Place the workpiece on the appropriate tool rest for the desired operation.
- Move the workpiece towards the grinding wheel until it lightly touches. Move the workpiece back and forth across the front surface of the grinding wheel removing the amount of material desired.

▲ WARNING *To avoid serious injury, never grind on the sides of the grinding wheels.*

- If the drill bit sharpening plate was installed earlier, lay the drill bit flat in the "V" groove. Firmly hold on to the drill bit shank. Slide the drill bit towards the grinding wheel until it lightly touches. Keep the drill bit flat to the plate and rotate the drill bit.
- The operator may place the hot end of the workpiece into the water in the quench tray to cool it.
- After completing the grinding operations, turn "OFF" the Bench Grinder by pushing down on the power switch. CAUTION: It will take a few minutes for the grinding wheels to come to a complete stop.
- Turn the variable speed switch counterclockwise to return it to its slowest setting.
- Turn "OFF" the flexible work light.

▲ CAUTION *The flexible work light housing will remain hot for a few minutes after turning it "OFF".*

- Avoid contact with housing until it is cool. Unplug the Bench Grinder from the power source.

NOTE: To prevent unauthorized use of the Bench Grinder, the power switch has a removable locking key. With the power switch in the "OFF" position, pull the locking key out. The Bench Grinder cannot be turned "ON" with the key removed. Insert the locking key to resume grinding operations.

Using the Wheel Dresser

Refer to Figure 13.

The wheel dresser is to be used on the grinding wheels. It will remove buildup up of material on the grinding wheel, remove imperfections and make the corners of the grinding wheel square.

DO NOT use the wheel dresser on the wire wheel.

- If the optional drill bit sharpening accessory plate was installed earlier, remove it and reassemble the right side tool rest (A) and adjust it until it is in the flat horizontal position as shown and 1/16" away from the grinding wheel.
- Turn "ON" the Bench Grinder. and then turn the variable speed switch clockwise until solid resistance is felt. Let the grinding wheel come up to a steady speed for one minute.
- After the grinding wheel has gotten to a steady speed, place the wheel dresser (B) flat on the tool rest with the serrated wheels facing the grinding wheel.
- Firmly hold on to the handle of the wheel dresser (B).

- Move the wheel dresser forward until the serrated wheels (D) make light contact with the grinding wheel (C). After contact has been made, slide the wheel dresser side to side across the tool rest to dress the grinding wheel until the edge of the grinding wheel is square and the surface is clean.
- After the operator has completed dressing the grinding wheel, turn "OFF" the Bench Grinder and let the grinding wheel come to a complete stop.
- Inspect the grinding wheel for any damage!
- The grinding wheel may now be slightly smaller in diameter after dressing. Read just the tool rests and spark arrestors to maintain a 1/16" clearance to the grinding wheel.

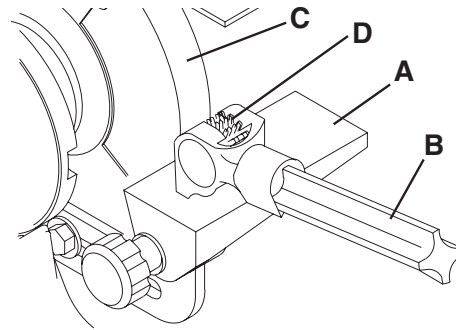

Figure 13

Changing the Grinding Wheel

Refer to Figures 14 and 15, page 11.

Due to normal wear, both wheels will need to be replaced occasionally.

- Turn the power switch OFF and unplug the power cord from its power source.
- Rotate the eyeshield up to access the tool rest.
- Loosen the tool rest knob and rotate the tool rest away from the grinding wheel.
- Remove three knobs (A) from guard completely.
- Remove wheel cover (B).
- Place a crescent wrench (D) (not included), on the arbor hex nut (E). Place the box end of the special wrench (F) (included with your grinder) onto the flats of the arbor shaft (G).

NOTE: The arbor hex nut on the left arbor shaft is left hand threaded and is loosened by rotating it clockwise.

The arbor hex nut on the right arbor shaft is right hand threaded and is loosened by rotating it counterclockwise.

- Remove the outer wheel flange (H) and then the abrasive wheel (I) from the arbor shaft.

▲ WARNING *The new abrasive wheel to be put onto the grinder must have a higher R.P.M. rating than the grinder (3400 R.P.M.). The new abrasive wheel must have the correct outer wheel diameter and bore diameter as original wheels. The label on the side of the abrasive wheel must stay on. DO NOT remove this label.*



OPERATION (CONTINUED)

8. Replace the abrasive wheel, outer wheel flange and arbor hex nut. **NOTE:** The arbor hex nut on the left arbor shaft is left hand threaded and is tightened by rotating it counter-clockwise. The arbor hex nut on the right arbor shaft is right hand threaded and is tightened by rotating it clockwise.

▲ WARNING **DO NOT OVER-TIGHTEN the arbor hex nut as this may damage the abrasive wheel and cause serious injury to the operator.**

9. Replace wheel cover and knobs.

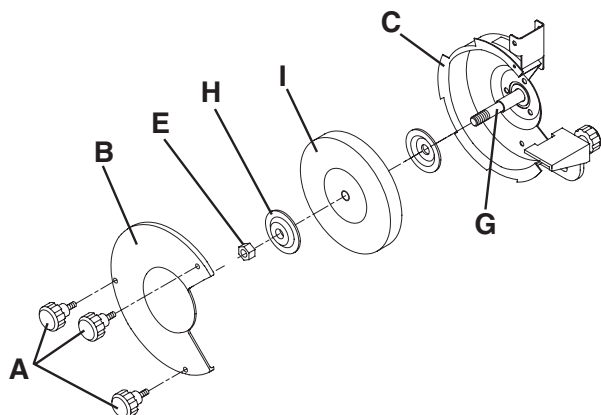

Figure 14 - Parts of the grinding wheel assembly.

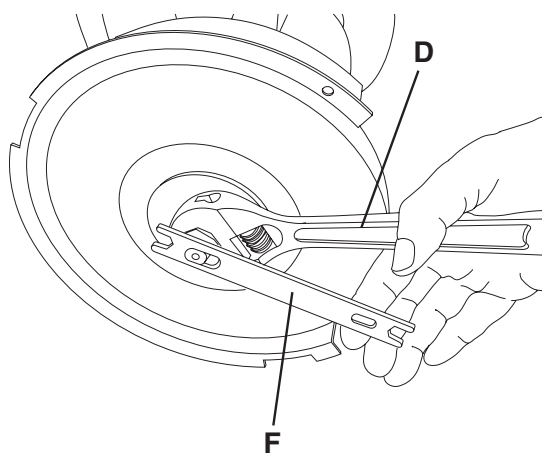

Figure 15 - Using wrenches to change the grinding wheel.

Wire Wheel or Buffing Wheel

Refer to Figure 16.

Wire wheel (A) (supplied with grinder) or buffing wheel can be used with your grinder. Depending on the thickness of the wheel, you will need to add one or more spacers to allow the arbor hex nut to tighten correctly. These spacers are identical to each other. Figure 16 shows the correct placement of the spacers (B) and (C).

NOTE: One spacer (B) should always go onto the arbor shaft first. The second spacer (C), if needed, will go on next to the arbor hex nut (D) as shown. Always use the wheel flanges (E) that came with the grinder for both wire wheel and buffing wheels. See section "Changing the Grinding Wheel" for correct procedure of changing wheels.

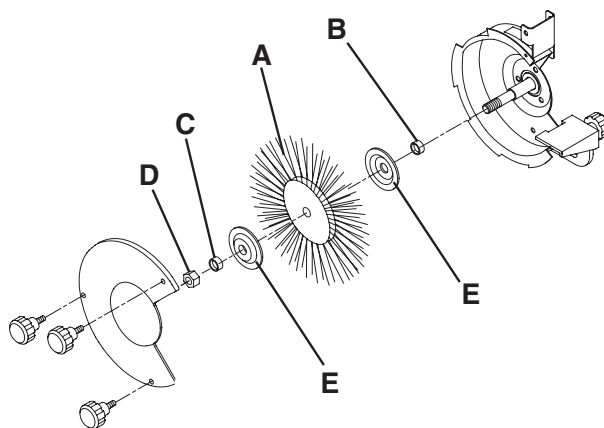

Figure 16 - Parts of the wire wheel assembly.

MAINTENANCE

WARNING: Turn the power switch "OFF" and unplug the power cord from its power source prior to any maintenance.

Lubrication

The Bench Grinder has sealed lubricated bearings in the motor housing that do not require any additional lubrication from the operator.

Cleaning

With the Bench Grinder unplugged, rotate the abrasive wheels slowly and inspect for any damage or trapped shavings.

▲ WARNING **REPLACE the abrasive wheels if there is any damage at all. FAILURE to replace a damaged wheel can cause serious injury to the operator.**

▲ CAUTION **DO NOT USE FLAMMABLE MATERIALS to clean the Bench Grinder. A clean dry rag or brush is all that is needed to remove dust and debris buildup.**

▲ WARNING **Repairs to the Bench Grinder should be performed by trained personnel only. Contact your dealer for authorized service. Unauthorized repairs or replacement with non-factory parts could cause serious injury to the operator and damage to the Bench Grinder.**

**TROUBLESHOOTING GUIDE**

▲ WARNING *TO PREVENT INJURY TO YOURSELF or damage to the Bench Grinder, turn the switch to the "OFF" position and unplug the power cord from the electrical receptacle before making any adjustments.*

Symptom	Possible Cause(s)	Corrective Action
Motor does not run	<ol style="list-style-type: none"> 1. Machine not plugged in 2. Power switch in "OFF" position 3. Power cord is faulty 4. Fuse or circuit breaker are open 5. Damaged motor 6. Fuse on circuit board blown 	<ol style="list-style-type: none"> 1. Plug power cord into electrical receptacle 2. Lift switch to "ON" position 3. Contact your dealer 4. Overloaded electrical circuit 5. Contact your dealer 6. Replace fuse
Motor does not have full power	<ol style="list-style-type: none"> 1. Incorrect line voltage 2. Damaged motor 	<ol style="list-style-type: none"> 1. Have a qualified electrician check line for proper voltage 2. Contact your dealer
Motor runs hot	<ol style="list-style-type: none"> 1. Motor is overloaded 2. Poor air circulation around motor 	<ol style="list-style-type: none"> 1. Reduce pressure on workpiece 2. Remove any blockage around motor
Motor stalls or runs slow	<ol style="list-style-type: none"> 1. Motor is overloaded 2. Incorrect voltage 3. Poor air circulation around motor 	<ol style="list-style-type: none"> 1. Reduce pressure on workpiece 2. Have a qualified electrician check for proper voltage 3. Contact your dealer
Fuse blows or circuit breaker trips	<ol style="list-style-type: none"> 1. Motor overloaded 2. Overloaded electrical circuit 3. Wrong fuse or circuit breaker 4. Undersized or excessive length of extension cord, see manual 5. Grinding wheels are blocked 	<ol style="list-style-type: none"> 1. Reduce pressure on workpiece 2. Reduce the amount of items on circuit 3. Replace with correct fuse or circuit breaker 4. Use correct size 5. Unplug machine and remove obstruction





REPAIR PARTS LIST FOR 9682080 8" VARIABLE SPEED BENCH GRINDER

GETTING STARTED

SAFETY / SPECIFICATIONS

ASSEMBLY / INSTALLATION

OPERATION

TROUBLESHOOTING

MAINTENANCE / REPAIR

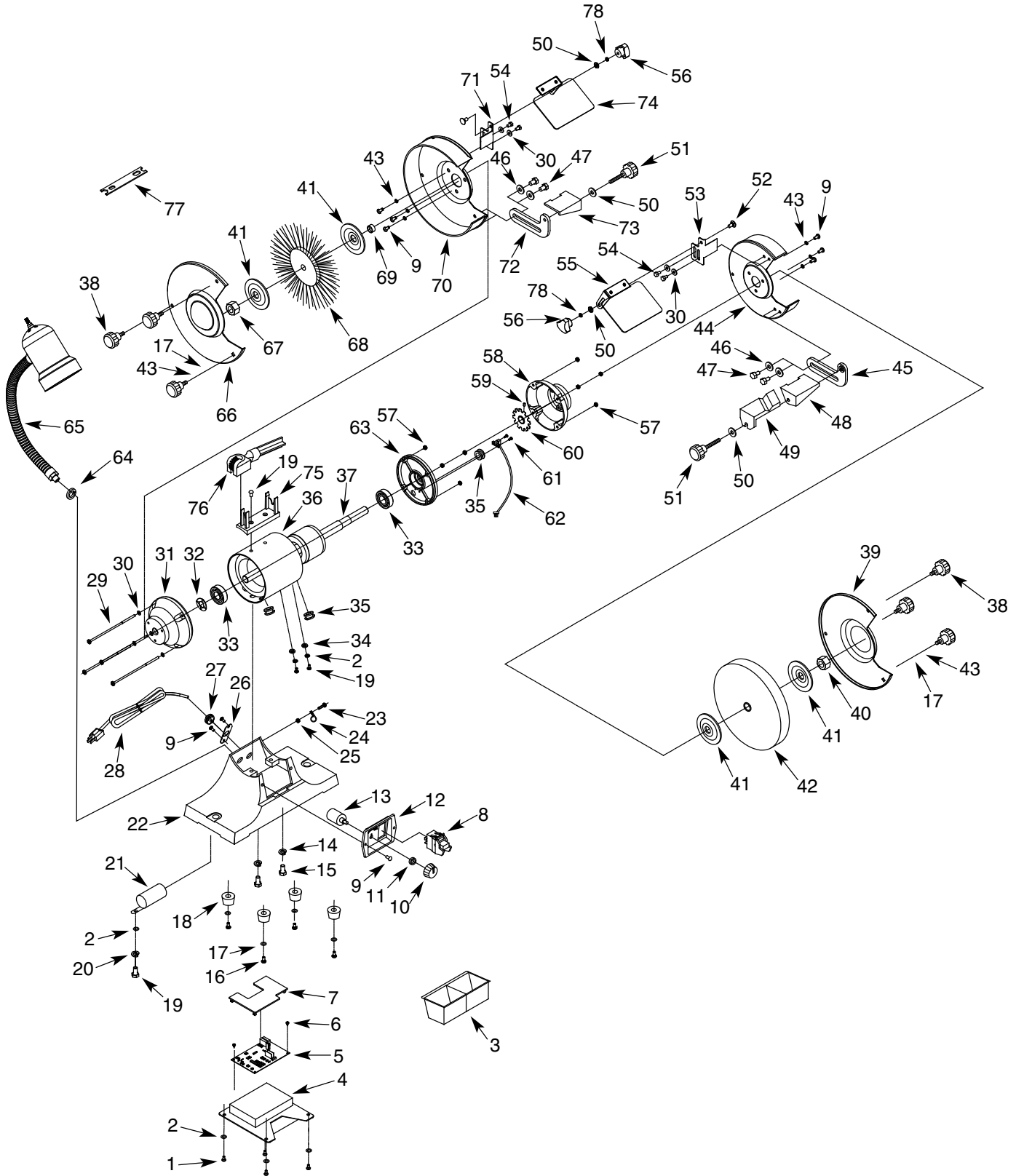

REPAIR PARTS LIST FOR 9682080 8" VARIABLE SPEED BENCH GRINDER

KEY			
NO.	PART NO.	DESCRIPTION	QTY.
1	*	4-0.7 x 6mm Pan Head Screw*	4
2	*	4mm Flat Washer*	7
3	9636145.00	Quench Tray	1
4	9636146.00	Base Plate	1
5	9637016.00	Circuit Board	1
6	9636148.00	2.9 x 5mm Tap Screw	2
7	9636149.00	Cover	1
8	9636150.00	Switch w/Key	1
9	*	5-0.8 x 10mm Pan Head Screw	10
10	9636151.00	Knob	1
11	9636152.00	Spacer	1
12	9636153.00	Switch Plate w/Label	1
13	9636154.00	Potentiometer	1
14	*	8mm Lock Washer*	2
15	9617074.00	8-1.25 x 22mm Socket Head Bolt	2
16	*	5-0.8 x 16mm Pan Head Screw	4
17	9600968.00	5mm Flat washer	10
18	9636155.00	Foot	4
19	*	4-0.7 x 8mm Pan Head Screw*	5
20	*	4mm Lock Washer*	3
21	9636156.00	Capacitor	1
22	N/A	Base	1
23	*	4-0.7 x 16mm Pan Head Screw	1
24	9636157.00	Knob	1
25	*	4-0.7mm Hex Nut	1
26	9636158.00	Cord Plate	1
27	9636159.00	Strain Relief	1
28	9636160.00	Line Cord	1
29	9637017.00	5-0.8 x 160mm Pan Head Screw	4
30	*	5mm Flat Washer (N)*	8
31	N/A	Left End Bell	1
32	9631611.00	40mm Wavy Washer	1
33	9601901.00	6203zz Ball Bearing	2
34	9605156.00	4mm Serrated Washer	2
35	9636162.00	Grommet	3
36	N/A	Stator	1
37	N/A	Armature	1
38	9636163.00	Knob	6
39	9636164.00	Right Guard Cover	1
40	9627338.00	16-2.0mm Hex Nut	1

* Standard hardware item available locally

Δ Not shown

N/A Not available

KEY			
NO.	PART NO.	DESCRIPTION	QTY.
41	9636165.00	Flange	4
42	9602033.00	Grinding Wheel 60#	1
43	*	5mm Lock Washer*	16
44	9636167.00	Right Guard w/Label	1
45	9636168.00	Right Toolrest Support	1
46	*	8mm Flat Washer*	4
47	*	8-1.25 x 12mm Hex Head Bolt*	4
48	9636169.00	Right Toolrest	1
49	9636170.00	Drill Bit Sharpening Plate	1
50	*	6mm Flat Washer*	2
51	9636171.00	Knob	2
52	9632500.00	6-1.0 x 12mm Carriage Bolt	2
53	9636172.00	Right Spark Deflector	1
54	9609720.00	5-0.8 x 10mm Hex Head Bolt	4
55	9636173.00	Right Eyeshield Assembly	1
56	9636174.00	Knob	2
57	*	5-0.8mm Hex Nut*	8
58	N/A	Right End Bell	1
59	9603069.00	5-0.8 x 6mm Set Screw	1
60	9636175.00	Feedback Wheel	1
61	9636176.00	2.5 x 6mm Pan Head Screw	2
62	9636177.00	Sensor	1
63	N/A	Cover	1
64	*	12mm Flat Washer*	1
65	9636178.00	Work Lamp w/Label	1
66	9636179.00	Left Guard Cover	1
67	9627339.00	16-2.0mm Hex Nut LH	1
68	9636468.00	Wire Wheel	1
69	9636181.00	Wire Wheel Spacer	2
70	9636182.00	Left Guard w/Label	1
71	9636183.00	Left Spark Deflector	1
72	9636184.00	Left Toolrest Support	1
73	9636185.00	Left Toolrest	1
74	9636186.00	Left Eyeshield Assembly	1
75	9636187.00	Support	1
76	9636188.00	Wheel Dresser	1
77	9636189.00	Wrench	1
78	*	6mm Lock Washer*	2
Δ	9643316.01	Operator's Manual	

GETTING STARTED

SAFETY / SPECIFICATIONS

ASSEMBLY / INSTALLATION

OPERATION

TROUBLESHOOTING

MAINTENANCE / REPAIR



NORSE Warranty

NORSE by C.H. Hanson warrants their products to be free of defects in material or workmanship. This warranty does not cover defects due directly or indirectly to misuse, abuse, normal wear and tear, failure to properly maintain the product, heated, ground or otherwise altered, or used for a purpose other than that for which it was intended.

The warranty does not cover expendable and/or wear part (i.e. v-belts, screws, abrasives, jaws), damage to tools arising from alteration, abuse or use other than their intended purpose, packing and freight. The duration of this warranty is expressly limited to the terms noted below beginning from the date of delivery to the original user.

The NORSE branded items carry the following warranties on parts:

All NORSE branded Tools and Accessories 1 YEAR

The obligation of NORSE by C.H. Hanson is limited solely to the repair or replacement, at our option, at its factory or authorized repair agent of any part that should prove inoperable. Purchaser must lubricate and maintain the product under normal operating conditions at all times. Prior to operation become familiar with product and the included materials, i.e. warnings, cautions and manuals.

Failure to follow these instructions will void the warranty.

This warranty is the purchaser's exclusive remedy against C. H. Hanson for any inoperable parts in its product. Under no circumstances is C. H. Hanson liable for any direct, indirect, incidental, special or consequential damages including loss of profits in any way related to the use or inability to use our products. This warranty gives you specific legal rights which may vary from state to state.

SERVICE & REPAIR

1. If a NORSE product requires a repair or warranty service **DO NOT** return the product to the place of purchase.
2. All warranty related work must be evaluated and approved by NORSE.
3. Prior to returning any item the user must obtain factory approval and a valid RGA number.
4. For instructions and RGA number call toll free (800) 827-3398.



NORSE - a C.H. Hanson brand
2000 N. Aurora Rd., Naperville, IL 60563 U.S.A.
or call: 1-800-827-3398

