



# CLEANCUT CONVERTIBLE INSTALLATION GUIDE

COPYRIGHT © 2017 SAFEWAY SAFETY STEP, LLC  
(DBA "CleanCut) All Rights  
Reserved

*Reproduction or Distribution of this Installation Manual is Strictly Prohibited*

**VIDEO INSTRUCTIONS CAN BE VIEWED AT**  
[cleancutbath.com](http://cleancutbath.com)

**IMPORTANT – PLEASE WATCH VIDEO PRIOR TO READING DIRECTIONS  
AND BEFORE BEGINNING INSTALLATION**

IT IS VERY IMPORTANT THAT ALL INSTRUCTIONS IN THE INSTALLATION MANUAL ARE FOLLOWED THOROUGHLY.

**VIDEO INSTRUCTIONS CAN BE VIEWED AT  
[cleancutbath.com](http://cleancutbath.com)**

INSTALLATION OF THE CLEAN CUT CONVERTIBLE REQUIRES USE OF POTENTIALLY DANGEROUS TOOLS.

SAFEWAY SAFETY STEP, LLC (DBA CLEAN CUT) ACCEPTS NO RESPONSIBILITY FOR ANY TYPE OF INJURY, LOSS OR DAMAGE OCCURRED DURING INSTALLATION OR SUBSEQUENT USE OF THE CLEAN CUT CONVERTIBLE.

FAILURE TO FOLLOW THE INSTRUCTIONS IN THIS INSTALLATION MANUAL SHALL VOID ANY WARRANTY GIVEN WITH RESPECT TO THE CLEAN CUT CONVERTIBLE.

IMPORTANT REMINDER - PLEASE RETURN THE PACKET THAT INCLUDES WARRANTY REGISTRATION INFORMATION.

ADDITIONAL QUESTIONS?

CLEAN CUT REPRESENTATIVES ARE AVAILABLE TO ANSWER QUESTIONS MONDAY-FRIDAY FROM 9AM-4PM EST.  
FOR QUESTIONS, PLEASE CALL (877) TUB-STEP (882-7837).

**MSDS SHEET FOR ENCLOSED ADHESIVE AVAILABLE UPON REQUEST.**

Thank you for your interest in the CleanCut Convertible. This installation manual includes an overview of the CleanCut Convertible installation kit as well as instructions pertaining to the step-by-step instructions for CleanCut Convertible installation.

### CleanCut Convertible Installation Kit

The CleanCut Convertible installation kit included the following items:

- One CleanCut Convertible
- One CleanCut Convertible Support Box Structure (large & small box)
- Template to be used for cutting the tub
- Two tubes of required adhesive and angled extension
- Waterproof sealant material
- Furring/Spacing strip

### Tools & Materials

In addition to the items included in the installation kit, the following tools and materials are recommended to have on hand for installation.

### Additional Tools & Materials

Butane Torch

Card Paper

Caulking Gun (High Torque Ratio)

Chisels

Deburring Tool (i.e., file, knife)

Denatured Alcohol

Drain Screens

Drill & Drill Bits

Drop Cloths

Drywall plane or Rasp

Drywall Router

Dust Masks

Dust Pan & Brush

Ear Protection

Extension Cord

Fire Extinguisher

Gloves

Hammer

Jigsaw with 2" Blade

Masking Tape

Mirror (small)

Paper Towels

Pliers

Pressure Treated 2 X4's

Protective Eye Wear

Reciprocating Saw with Metal Blades

Scissors

Screw Driver

Screws- Assorted Sizes

Side Grinder with 4.5" Diamond Blade\*

Red Sharpie Marker

Utility Knife

Vacuum with Attachment\*

Wood Shims

\* These items are available for purchase from CleanCut

## Preparing the Tub

1. Before beginning any work, it is important to inspect the tub for existing chips, markings or other types of damage. If performing the installation on behalf of others, make the resident or property manager aware of any existing damage prior to beginning the installation process. Existing damage may be made worse during the tub cutting process.
2. Prior to beginning the installation, remove any personal items from the bathroom area to create extra space during the installation and to prevent possible damage or exposure to dust and debris that may result during the installation process. When scheduling the installation, request for the resident or property manager to remove the belongings.
3. One method to minimize the areas where dust can settle is to use a 2-ply drop cloth with the paper side up to catch and trap dust and other shavings. In particular, a drop cloth should be taped into the bottom of the tub. This will help to collect debris as well as to help prevent accidentally scratching the bottom surface of the tub. The drain of the tub should be completely covered to prevent any shavings from going down into the drain. Make sure that there is no water or dampness in or around the tub.

*Due to the significant amount of dust created when cutting a cast-iron tub, it is recommended that all walls and surfaces are covered, including the floor, before cutting the tub. See other considerations for cutting cast-iron tubs in the following section.*

4. Once the tub area is prepared for installation, it is necessary to mark the tub to determine the section that will be cut to make room for the CleanCut Convertible. First, if placing the CleanCut Convertible in the middle of the bathtub, measure the length of the tub and determine the midpoint of the tub and measure back, half the distance of the CleanCut Convertible itself. Using the template that was included in the installation kit, place the template flush against the tub and begin tracing. Use a red sharpie marker so as to make the lines that are traced easily visible. Flip the template over and now trace the outside of the tub. Keep in mind that it may not be possible to place the CleanCut Convertible directly in the center of the tub due to obstructions in the tub area such as the placement of sinks, vanities or commodes. It may be advisable to offset the CleanCut Convertible to accommodate other safety features, such as grab bars or bath seats.

## Cutting the Tub

The tub has been marked and is ready to cut. Safety is of highest importance and it is critical to remember to use the proper safety equipment when cutting the tub. Protective eye and ear wear and filter mask are required.

The CleanCut Convertible can be installed in fiberglass, steel or cast- iron tubs. On fiberglass or steel tubs, use a side grinder with the diamond blade to make necessary entry points for the reciprocating saw. For cast- iron tubs, the side grinder with the diamond blade is the only cutting tool used. If you are cutting a cast-iron tub, please read the special considerations noted below before beginning to cut.

1. The first corner notches will be made with the side-grinder as illustrated in Figure 1 below.
2. Using the reciprocating saw on fiberglass and steel tubs, cut out the bottom markings on each side of the tub.
3. Then cut all four downward cuts. Finish by cutting the two adjoining top pieces.

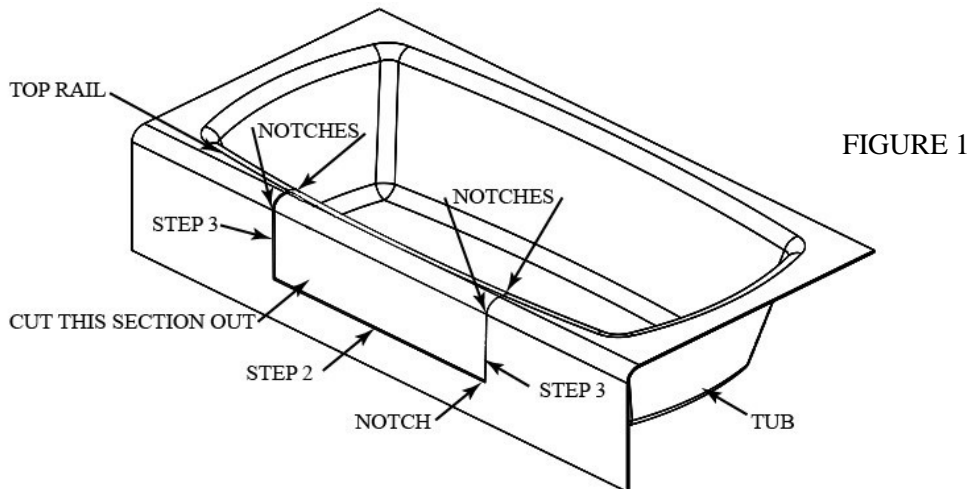

FIGURE 1

4. The opening for the CleanCut Convertible is now complete and you can remove the cut-out section. Use caution when removing the cut-out section as there may be sharp or jagged edges both on the cut-out segment and along the edges of where the cuts were made on the sides of the tub. It is helpful to spend a moment to file down any potential hazard areas. This prevents potential snags with fitting the CleanCut convertible and reduces the risk of injury.
5. After the cut out section of the tub has been removed, take a few moments to clean the area in around the tub. Using a dust pan and broom, sweep all dust and shavings. Complete the clean-up by thoroughly vacuuming the entire area. Wash your hands before you start any work on the step itself. This will eliminate transferring any dirt or dust to the product.

#### **SPECIAL CONSIDERATIONS FOR CUTTING CAST-IRON TUBS**

Due to the significant amount of dust created when cutting a cast-iron tub, it is recommended that you cover all tub and exposed bathroom walls and surfaces (including the floor) with a 2-ply drop cloth to minimize the amount of dust that can settle. Also, it is recommended that the installer wears protective cover-alls and shoe covers, in addition to protective wear outlined earlier, to minimize the clean-up after cutting out a cast-iron tub.

Please note that there are several differences when cutting out a cast-iron tub compared to a fiberglass or steel tub. The side-grinder with a 4.5" diamond blade is the only tool used when cutting a cast-iron tub. Cast-iron tubs are a bit more challenging to cut. Vacuum the dust and shavings as you cut the tub with the use of the dust buddie that contains a cover plate and vacuum attachment. It connects directly to the grinder to minimize dust output when cutting the cast-iron.

Follow the same pattern when cutting a cast-iron tub as described for the fiberglass and steel tubs. Begin by cutting the bottom lines of your template, followed by the downward vertical cuts leaving the top adjoining pieces for last.

Be cognizant of potential safety issues when cutting the tub such as sparks generated during cutting, as well as items that may be located within the tub wall such as water lines, insulation or other items.

#### **Measuring & Cutting the CleanCut Convertible**

Once you have completed cutting out a section of the tub, you can begin to fit the CleanCut Convertible into the tub opening. The first step is to determine if the CleanCut Convertible will fit the tub to complete the installation. First, measure the top rail width measurement as well as the width measurement approximately 10.5" down the tub (bottom measurement). Based on these measurements, please consider the following:

- The maximum top rail measurement for the CleanCut Convertible is 6.0".
- The maximum bottom rail measurement for the CleanCut Convertible is 7.0".

1. Take a stack of heavy card stock paper. This is the paper used to trace the cut-out section of the tub onto the CleanCut Convertible. Place the card paper onto the left end and trace the outline of the pattern onto the paper. Once completed, mark this tracing as "Left", so as to remember which side was traced. It is also helpful to place an arrow on the template to indicate which direction is the inside of the tub.
2. Repeat the process for the right side of the tub. Mark this tracing "Right".
3. Cut out the proper templates with scissors making sure to keep to the inside of the tracings.

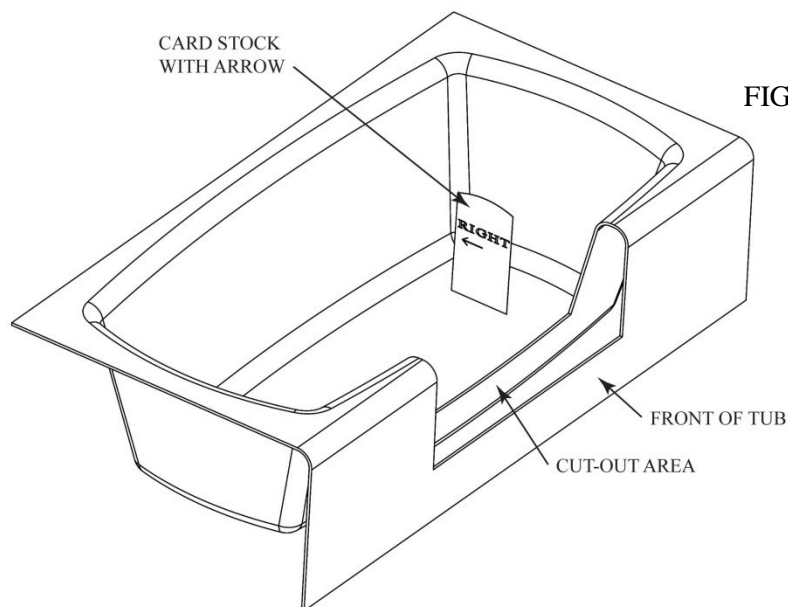

FIGURE 2

4. It is time to transfer the shape of our cut tub onto the CleanCut Convertible. Before continuing, it is recommended that a drop cloth approximately 3' x 4' size be placed on the floor to prevent any dust or other debris from transferring onto the CleanCut Convertible.
5. Place the left end of the CleanCut Convertible on the ground in order to trace the right side of the CleanCut Convertible. Place the top of the paper template approximately 1/2" from the top of the CleanCut Convertible. Place the tracing on the step so the slope is similar to that of the tub. Trace the outline of the paper onto the CleanCut Convertible. Continue the lines with a straight edge down and around the corners. Repeat the same procedure for the left end of the CleanCut Convertible. Remember to place the paper template approximately 1/2" down from the top of the CleanCut Convertible. Continue the lines with a straight edge down and around the corners (Figure 3).

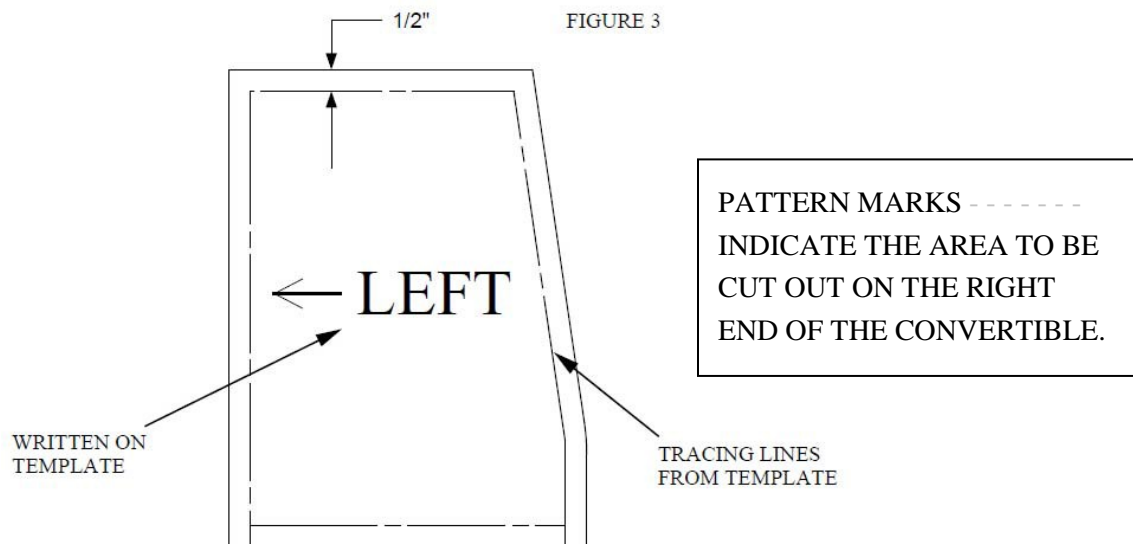
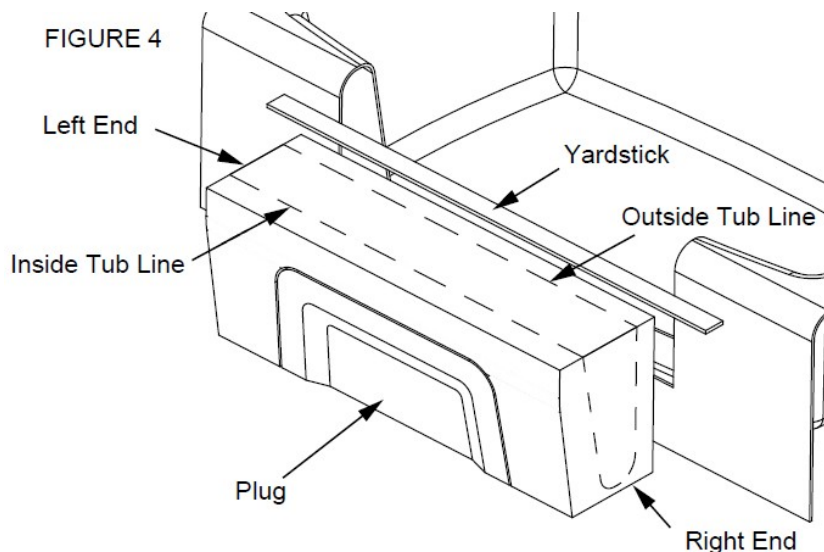
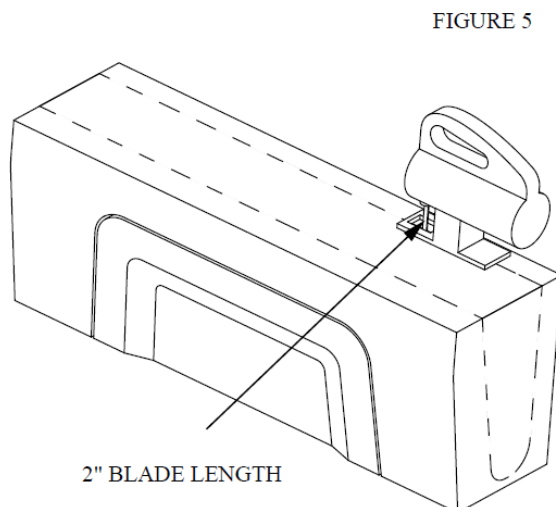

FIGURE 3

6. Next, place Convertible as shown and connect each side of the outside tub line using a yard stick.
7. Use a tape measure and transfer the shape of the inside of the tub edge to the step. Remember that the tub may be narrower in the center, so measurements for the inside line must be made every 3" from one end of the CleanCut Convertible to the other. Once completed, use your yard stick and marker to connect the markings for the inside line (Figure 4)



8. Cut the CleanCut Convertible to fit the cut-out tub opening using a jigsaw. (Figure 5). Fasten Velcro-stripping on both sides of the jigsaw to prevent making any unwanted marks on the CleanCut Convertible. It is important that a 2" blade is used to cut out the CleanCut Convertible so as to prevent accidentally cutting through the top of the CleanCut Convertible frame. Snap off any excess length on the stock jigsaw blade beyond 2".



9. It is required that proper eye protection be worn while using the jigsaw. Cut the bottom of the CleanCut Convertible using the jigsaw cutting directly on the center of the traced lines. Upon reaching the corners while cutting, tilt the jigsaw outward to prevent cutting past your lines on the vertical ends of the CleanCut Convertible. Remember to tilt your blade on each corner. On the ends of the CleanCut Convertible, simply continue the cutting process with the jigsaw.

10. Use a drywall plane or deburring tool to rid the CleanCut Convertible of any remaining pieces.
11. Place the CleanCut Convertible into position. Use a small pocket mirror and look for areas on the CleanCut Convertible that may be catching and prohibiting it from freefalling onto the tub. Use the jigsaw or drywall plane to trim the CleanCut Convertible where necessary.
12. Continue this process and repeat as necessary until a desirable close fit is achieved. The CleanCut Convertible should free fall onto the tub without catching or binding.
13. Having completed use of the jigsaw and routing tool, take a moment to tidy the tub and work area.

### Support Structure & Waterproof Membrane Installation

Once the CleanCut Convertible has been cut and a satisfactory fit into the tub opening has been achieved, it will be necessary to assemble the support box structure to provide support to the CleanCut Convertible. Once the support box has been properly positioned, a waterproof membrane will be applied to the open cut out channel. An example of the CleanCut Convertible and the support structure and waterproof membrane is illustrated in Figure 6.

The CleanCut Support box structure consists of one small and one large Support Box. The large support box will compress over the top of the small box to the necessary height to provide support to the CleanCut Convertible.

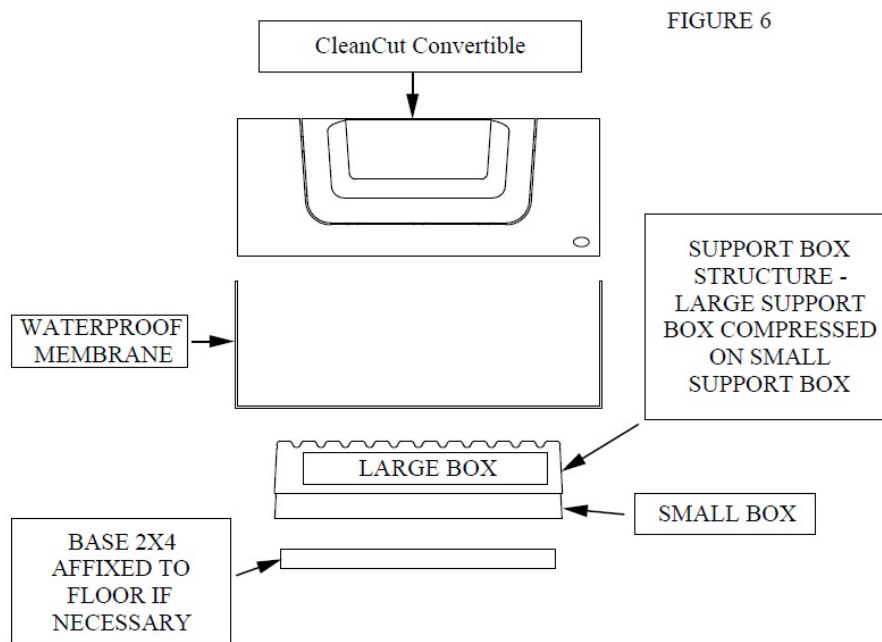

**It is important to understand that each tub has variations and modifications may be necessary in the field. For fiberglass and other types of tubs, it may be necessary to adjust the installation of the support boxes based on the framing or support material present on the inside channel of the tub. For example, you may only need to use one of the support structures based on the height of the bathtub.**

1. It may be necessary to adjust the Support Box structure according to the conditions present during your installation. For example, for wooden sub-floors, begin by screwing a treated 2x4 directly to the sub-floor to serve as the base for our support structure. For concrete floors, a treated 2x4 is adhered directly to the concrete floor. The 2x4 might need to be cut into several sections if there is a support brace in the cut outchannel.



- Build the Support Box structure to appropriate height. If working with a concrete sub-floor, thoroughly inspect and clean the floor in the tub cut out channel prior to securing the treated 2x4. Remove any materials from the concrete that may cause an uneven surface. Apply adhesive directly to the concrete floor. Insert the 2x4's and thoroughly spread the adhesive on the concrete.

*If wood sub-floor is present, screw the 2x4 directly to the sub-floor, or you can use the adhesive to adhere it in place.*

- Prior to inserting the small Support Box, it is first necessary to secure a 22 1/2" long 2x4 into the channel of the small Support Box. Place a bead of adhesive around the inside of the Support Box and insert the 2x4. Place several screws into the small Support Box to properly adhere the 2x4 into proper position.

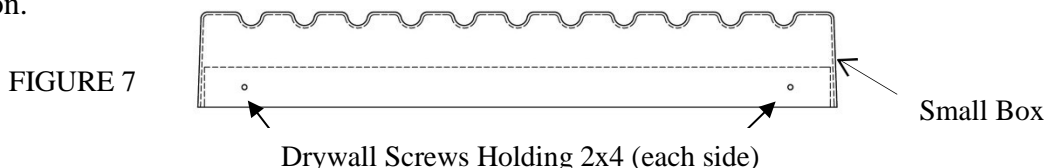

- Insert the small box in the channel. At this point, do not adhere the small support box to anything. Place the large support box into the channel and over the top of the small box. Place the CleanCut Convertible into position and compress downward to determine the proper height and placement for the support box structure.
- Once the support of the CleanCut Convertible has been achieved, remove, mark both the left and right ends of the small box where the large box is compressed while the boxes are in the tub opening channel. Once properly marked, remove both support boxes and label the markings "Left" and "Right" to avoid potential confusion. Uncompress the two support boxes from one another and begin the process to permanently adhere the boxes in proper position.
- Apply adhesive around the perimeter of the large box. Compress the small and large support box structures back together to the appropriate markings made earlier on the small box. Place the support structure back into the channel and insert the CleanCut Convertible to verify that proper placement has been achieved. Secure both sides of the support structure by placing 2 screws in each side. Make any final adjustments to the CleanCut Convertible or the support structure at this time (FIGURE 8).

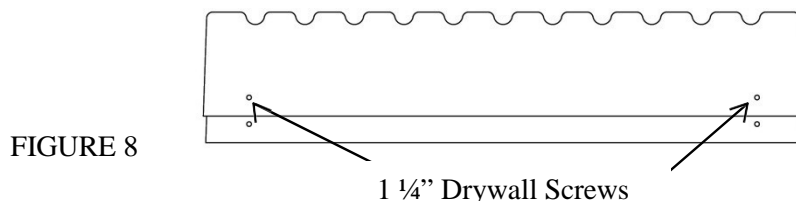

- Apply adhesive to the tops of the 2x4's that are already in place in the channel if they are needed for height, and insert the support box structure.
- Place the CleanCut Convertible into position once more to inspect the fit and position. This is the final opportunity to make any adjustments, if necessary.
- Once the support structure is properly positioned, apply the waterproof membrane over the entire cut out portion of the tub. First, unfold the membrane that was included in the installation kit. It will be necessary to cover the entire area of the tub cutout, including the two sidewalls. Remove the paper backing and stretch the membrane material to cover the area over the support boxes and sidewalls and adhere approx. 1/2" onto each side of the tub. It will be necessary to trim excess membrane material.

10. Place the CleanCut Convertible into position once more to inspect the fit and position. Also inspect and make sure that the waterproof wrap is completely covered by the CleanCut Convertible, and trim off any excess wrap.
11. Apply adhesive to the top of the waterproof membrane. Place a substantial bead of adhesive on the top of the tub where the CleanCut Convertible will be seated. Adhesive on the top of the tub reinforces the CleanCut Convertible.
12. Prior to placing the CleanCut Convertible into the channel, it is necessary to gently pass a low flame several times along the perimeter of the cut out where the tub is met. This will help promote bonding between the CleanCut Convertible and the bathtub once adhesive is applied. Use caution when using the torch and do not hold heat on one area of the product as it may discolor or melt.

Place the CleanCut Convertible into the channel and gently press into place.

### Completing the Installation

1. Before finalizing the installation, first make sure the CleanCut Convertible is in proper position and fully compressed. Press firmly and evenly on the CleanCut Convertible to ensure proper placement. Do not remove the plug for the remainder of the installation process.
2. Thoroughly wipe the tub area with isopropyl alcohol where the adhesive will bond, and allow enough time to flash off before applying the adhesive. **Do Not** apply the isopropyl alcohol directly on the adhesive as it will prevent the adhesive from drying or curing. **Do Not** use to clean or smooth your final bead as well.
3. It is necessary to caulk around the entire perimeter of the CleanCut Convertible. Before beginning to caulk, fasten the plug into the frame to ensure that frame holds the proper shape until the adhesive cures.
4. Begin by using the recommended adhesive along the sides of the CleanCut Convertible. Begin on the left side and complete the process, before moving to the right side and bottom. It is recommended that you wear gloves during this step to avoid direct exposure to the adhesive. Run your gloved finger along the beads and wipe the excess on a folded paper towel. Try to smooth the beads one-time only.
5. Underneath the bottom edges of the CleanCut Convertible are a bit more difficult to see and the angled tip should be used for completing this step. Use the small mirror to inspect the bead and to verify that all surfaces have been properly sealed.
6. Spend a few minutes at the end of the job to once again clean up the tub and the bathroom area. Upon completion, place a sign on the CleanCut Convertible warning not to use the tub for 2 days while the adhesive cures. Once the adhesive has cured, the plug may be removed.
7. The CleanCut Convertible installation is now complete. Safeway Safety Step, LLC (DBA CleanCut), sincerely thanks you for your interest in the CleanCut Convertible and looks forward to assisting you in any way possible. Visit our website at [www.cleancutbath.com](http://www.cleancutbath.com) or call us at (877) TUB-STEP (882-7837) with any questions or concerns you may have.

**IMPORTANT REMINDER** – if installing on behalf of others, please leave the customer packet that includes warranty registration information with the end-user at the conclusion of the installation.