

INSTALLATION INSTRUCTIONS

Ventilating Fan

Model No. FV-0811RQ1 FV-1315RQ1

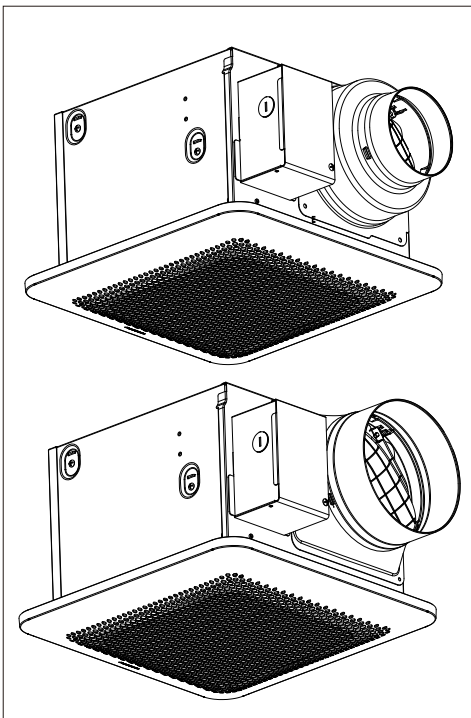

Contents

GENERAL SAFETY INFORMATION	2-3
DESCRIPTION	4
UNPACKING	4
SUPPLIED ACCESSORIES	4
DIMENSIONS	5
WIRING DIAGRAM	6
FEATURE	6
INSTALLATION (NEW CONSTRUCTION)	7-8
INSTALLATION (RETROFIT)	9
MAINTENANCE (CLEANING)	10
PRACTICAL GUIDE TO INSTALLATION	11
SPECIFICATIONS	11
PRODUCT SERVICE	12

READ AND SAVE THESE INSTRUCTIONS

Thank you for purchasing this Panasonic product.

Please read these instructions carefully before attempting to install, operate or service the Panasonic product. Failure to comply with instructions could result in personal injury or property damage. Please explain to users how to operate and maintain the product after installation, and this booklet should be presented to users.

Please retain this booklet for future reference.

GENERAL SAFETY INFORMATION

For Your Safety

To reduce the risk of injury, loss of life, electric shock, fire, malfunction, and damage to equipment or property, always observe the following safety precautions.

Explanation of symbol word panels

The following symbol word panels are used to classify and describe the level of hazard, injury, and property damage caused when the denotation is disregarded and improper use is performed.



Denotes a potential hazard that could result in serious injury or death.



Denotes a hazard that could result in minor injury.

The following symbols are used to classify and describe the type of instructions to be observed.

	This symbol is used to alert users to a specific operating procedure that must be followed in order to operate the unit safely.
	This symbol is used to alert users to a specific operating procedure that must not be performed.
	This symbol is used to alert users not to disassemble the equipment.
	This symbol is used to alert users to make sure of grounding when using the equipment with the grounding terminal.











TO REDUCE THE RISK OF FIRE, ELECTRIC SHOCK OR INJURY TO PERSONS, OBSERVE THE FOLLOWING :











- Use this unit only in the manner intended by the manufacturer. If you have any questions, contact the manufacturer.
- Before servicing or cleaning unit, switch power off at service panel and lock the service disconnecting means to prevent power from being switched on accidentally. When the service disconnecting means cannot be locked, securely fasten a prominent warning device, such as a tag, to the service panel.
- Installation work and electrical wiring must be done by qualified person(s) in accordance with all applicable codes and standards, including fire-rated construction.
- Sufficient air is needed for proper combustion and exhausting of gases through the flue (chimney) of fuel burning equipment to prevent back drafting. Follow the heating equipment manufacturer's guideline and safety standards such as those published by the National Fire Protection Association (NFPA), and the American Society for Heating, Refrigeration and Air Conditioning Engineers (ASHRAE) and the local code authorities.
- When cutting or drilling into wall or ceiling, do not damage electrical wiring and other hidden utilities.
- Ducted fans must always be vented to the outdoors.
- If this unit is to be installed over a tub or shower, it must be marked as appropriate for the application and be connected to a GFCI (Ground Fault Circuit Interrupter) - protected branch circuit.

GENERAL SAFETY INFORMATION CONTINUED

WARNING

-  These models are UL listed for tub and shower enclosures.
-  Do not disassemble the unit for reconstruction. It may cause fire or electric shock.
-  A statement to the effect that when the product is to no longer be used, it must not be left in place but remove, to prevent it from possibly falling.
-  Ceiling joist must be subjected to static load more than five times the weight of the product.
-  Do not install with a method which is not approved in the instructions.
-  Do not use these fans with any solid-state speed control device. Solid state controls may cause harmonic distortion which can cause motor humming noise.
-  These products must be properly grounded.
-  When one switch is connected with two or more products in parallel, the unit may not function. Therefore, parallel connection must not be allowed.

CAUTION

-  Do not install these ventilating fans where interior room temperature may exceed 104 °F(40 °C).
-  Make sure that the electric service supply voltage is AC 120 V, 60 Hz.
-  Follow all local electrical and safety codes, as well as the National Electrical Code (NEC) and the Occupation Safety and Health Act (OSHA).
-  Always disconnect the power source before working on or near the fan, motor, light fixture or junction box.
-  Protect the supply wiring from sharp edges, oil, grease, hot surfaces, chemicals or other objects.
-  Do not kink the supply wiring.
-  Provide make up air for proper ventilation.
-  For general ventilating use only. Do not use to exhaust hazardous or explosive materials and vapors.
-  Do not install the unit where ducts are configured as shown in Fig. A.
-  Not for use in cooking area. (Fig. B)
-  The special-purpose or dedicated parts, such as mounting fixtures, must be used if such parts are provided.

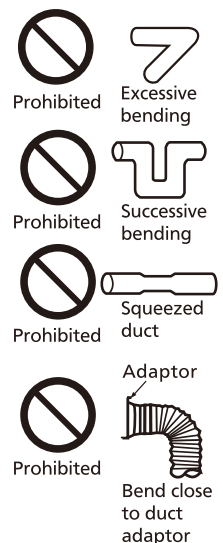

Fig. A

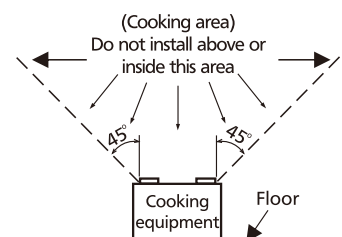

Fig. B

DESCRIPTION



The Panasonic ventilating fan models are listed by UL under UL file No. E78414. The Panasonic ventilating fan models use a sirocco Blower driven by a capacitor motor. The motor is designed to have an extended service life with reduced energy consumption. It also incorporates a thermal-cutoff for safety. The grille covering the fan body is a spring-loaded, quick remove type. A damper for preventing air counterflow is provided. The blower uses a high-capacity sirocco fan developed to reduce the noise level. FV-0811RQ1 has two speeds. "80" is low airflow and "110" is high airflow. FV-1315RQ1 has two speeds. "130" is low airflow and "150" is high airflow.

UNPACKING

Unpack and carefully remove the unit from carton. Refer to the supplied accessories list to verify that all parts are present.

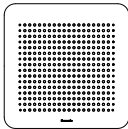
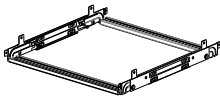
SUPPLIED ACCESSORIES

Part name	Appearance	Quantity
Grille		1
Flex-Z Fast™ bracket (with 4 tapping screw-ST4.2X20)		1

Part name	Appearance	Quantity
Installation instructions		1
Warranty sheet		1
Self-drilling screw		4

DIMENSIONS

FV-0811RQ1

Unit: inches (mm)

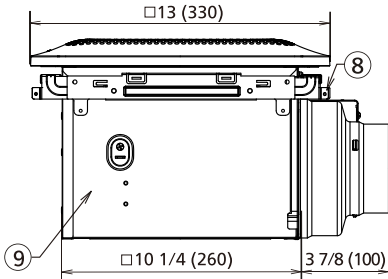
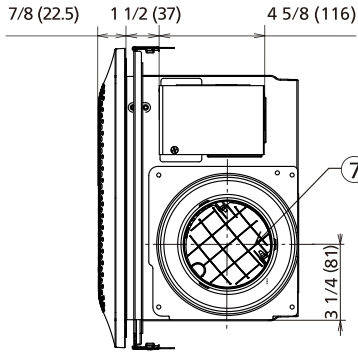
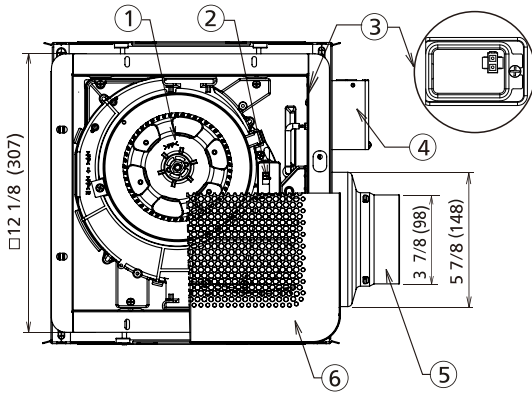

No.	Part name	No.	Part name
①	Blade	⑥	Grille
②	Pick-A-Flow switch	⑦	Damper
③	Connector plate	⑧	Flex-Z Fast™ bracket
④	Junction box	⑨	Fan body
⑤	Adaptor		

FV-1315RQ1

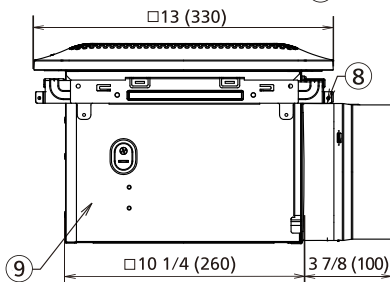
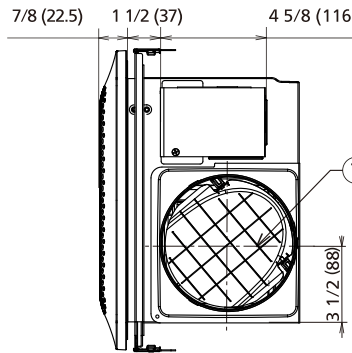
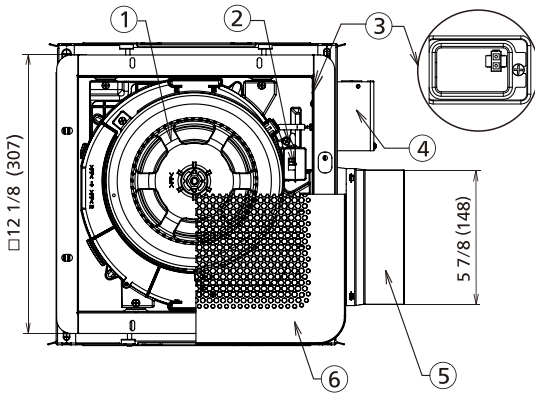

No.	Part name	No.	Part name
①	Blade	⑥	Grille
②	Pick-A-Flow switch	⑦	Damper
③	Connector plate	⑧	Flex-Z Fast™ bracket
④	Junction box	⑨	Fan body
⑤	Adaptor		

WIRING DIAGRAM

FV-0811RQ1

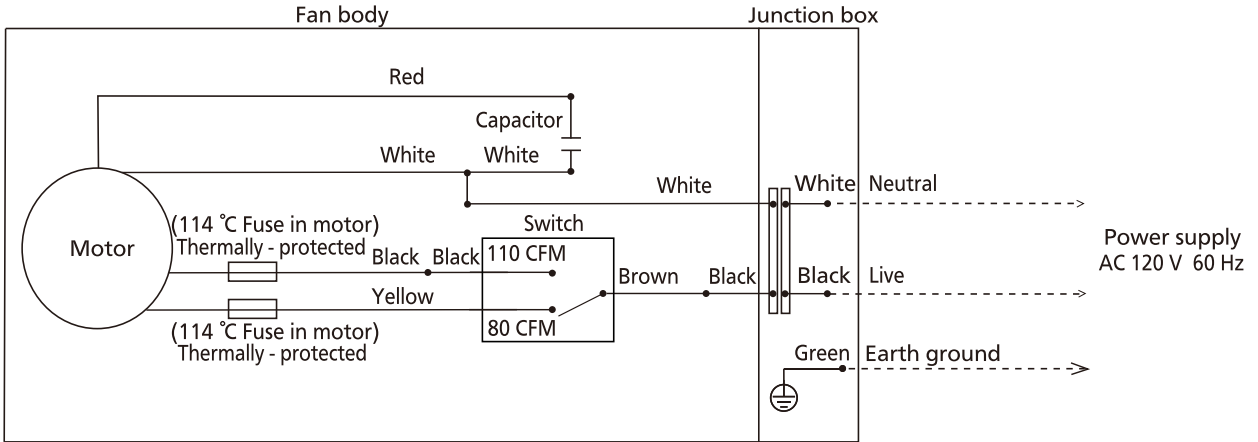

FV-1315RQ1

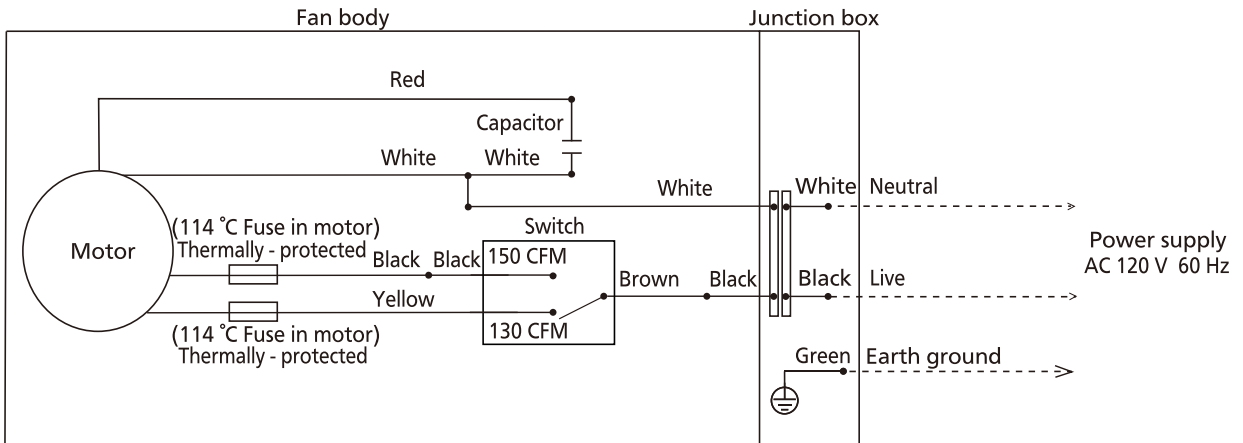

FEATURE

Pick-A-Flow Feature(only FV-0811RQ1)

This product comes with Pick-A-Flow speed option. The Pick-A-Flow switch on the surface of the product allows the option to choose 80-110 CFM.

Air volume options		Factory setting
80 CFM	110 CFM	80 CFM

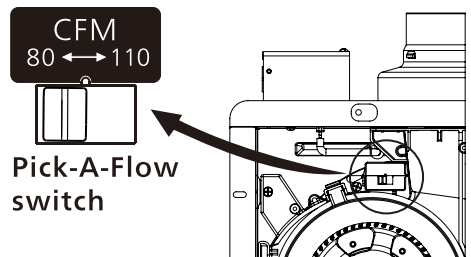

Pick-A-Flow Feature(only FV-1315RQ1)

This product comes with Pick-A-Flow speed option. The Pick-A-Flow switch on the surface of the product allows the option to choose 130-150 CFM.

Air volume options		Factory setting
130 CFM	150 CFM	130 CFM

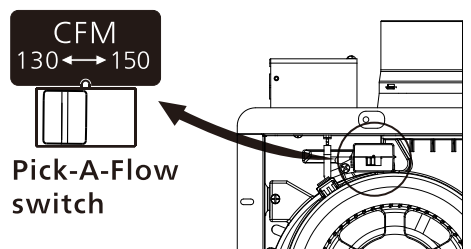

INSTALLATION (NEW CONSTRUCTION)

The fan position between joists from 16" to 24" on center can be adjusted flexibly.

CAUTION

! Please wear gloves to protect hands during the installation as follow.

1. Disconnect plug connector from receptacle and remove adaptor from fan body by removing the machine screw (M4X6) before installation. (Fig.1)

IMPORTANT:
Please remove the tape, which protects the damper during shipping and installation, from the duct adaptor as shown below.

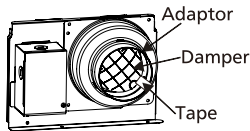

2. Bend down 4 tabs for positioning; install the Flex-Z Fast™ bracket to joists by using the 2 pre-installed tapping screws. (Fig.2)
3. Adjust the length of Flex-Z Fast™ bracket to fit the spacing between joists; fix the Flex-Z Fast™ bracket with the other two pre-installed tapping screws. (Fig.3)
4. Remove junction box cover and secure conduit or stress relief to junction box knock-out hole. (Fig.4)
5. Install the circular exhaust duct and secure it with clamps, or ties and seal it with mastic or approved foil tape. A 4 or 6 inch circular duct is needed to connect to the relevant part of adaptor.(Fig.4)
6. Install the adaptor to Flex-Z Fast™ bracket by using 2 self-drilling screws. (Fig.4)
7. Refer to wiring diagram on page 6. Follow all the local electrical safety codes as well as the National Electrical Code (NEC). Using UL approved wire nuts, connect house power wires to ventilating fan wires. (Fig.5)

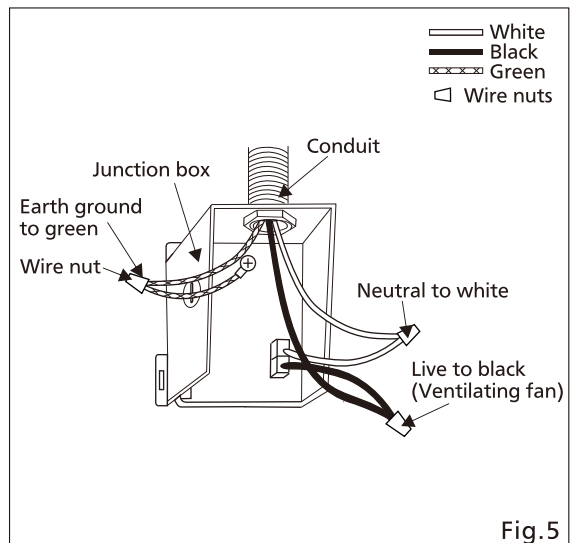
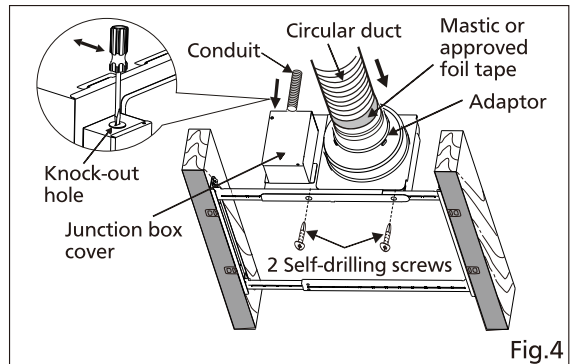
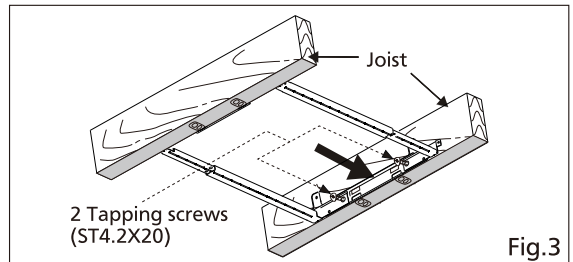
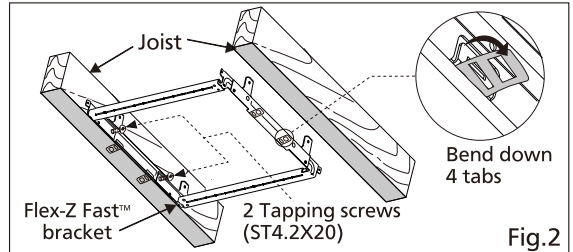
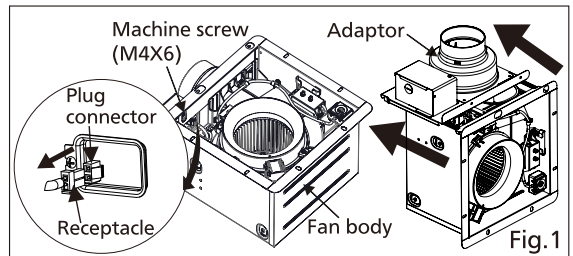

CAUTION

! Mount junction box cover carefully so that lead wires are not pinched.

! Insure the junction box cover encloses all the wires and is completely flush before locking in place with the attached screw.

INSTALLATION (NEW CONSTRUCTION) CONTINUED

8. Insert fan body and slide into adaptor assembly until the flange overlaps the Flex-Z Fast™ bracket. Secure the fan body to Flex-Z Fast™ bracket by using 2 self-drilling screws, plug connector to receptacle and secure the fan body to adaptor by using machine screw (M4X6). (Fig.6)

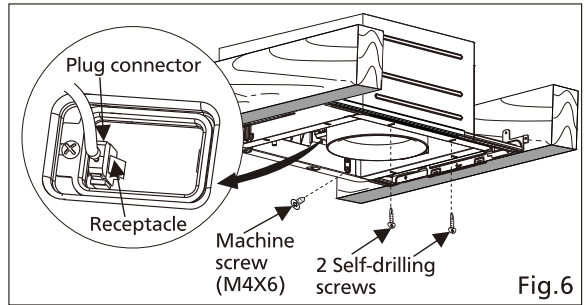

CAUTION

- Secure the duct adaptor to the fan housing with the machine screw (M4X6) by re-inserting and carefully screwing the adaptor to the housing. Please insure the screw is appropriately placed so it does not strip the teeth nor come in contact with the Flex-Z Fast™ bracket.

9. Finish ceiling work. Ceiling hole should be aligned with the inside edge of the flange. (Fig.7)
 10. Select the air volume speed by adjusting the switch. For FV-0811RQ1: Factory setting is "80" position; sliding "110" is high airflow position. (Fig.8). For FV-1315RQ1: Factory setting is "130" position; sliding "150" is high airflow position. (Fig.8)

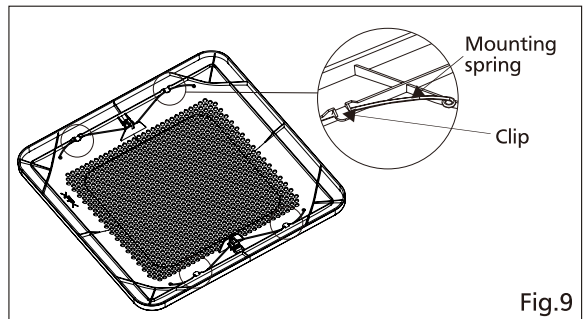
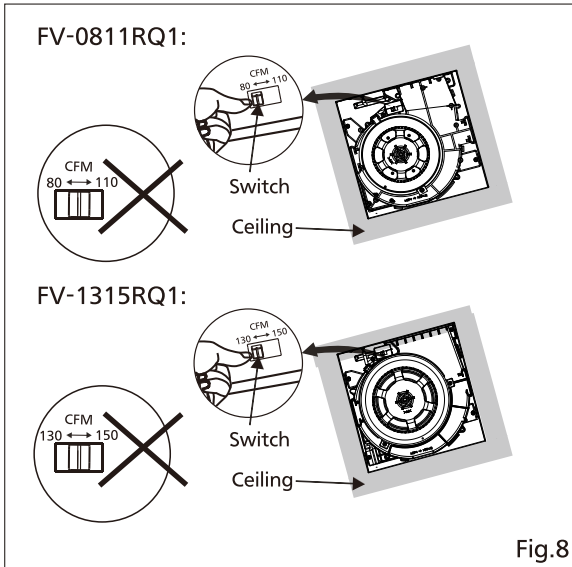
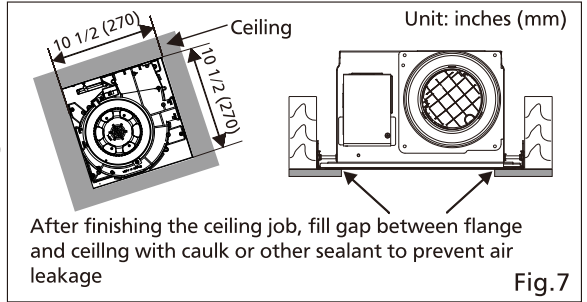

11. Take out the mounting springs from clips. (Fig.9)

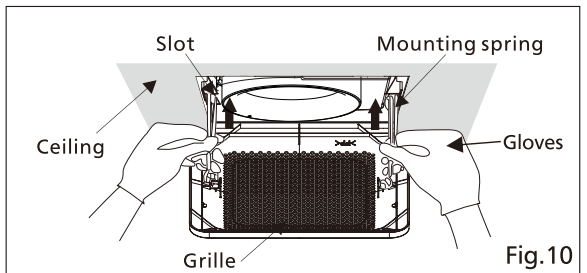

12. Insert one mounting spring into slot as shown in Fig.10. (If not, the grille may not be installed.)

13. Insert the other mounting spring into the slot as shown and mount grille to fan body. (Fig.11)

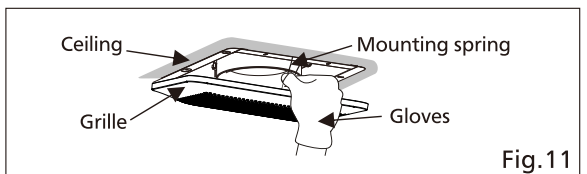

INSTALLATION (RETROFIT)

! WARNING

! Disconnect power source before working on unit.

1. Remove the existing fan and cut ceiling opening. Install the Flex-Z Fast™ bracket to joists by using the 4 pre-installed tapping screws (ST4.2x20). Leave existing ductwork and wiring in place. (Fig.12)

2. Follow the step 1, 4, 5, 7 on page 7. (Before connect the circular exhaust duct to the adaptor, pull down the circular duct from the ceiling.)

3. Install the adaptor to Flex-Z Fast™ bracket by using 2 self-drilling screws. (Fig.13)

4. Secure the fan body to Flex-Z Fast™ bracket by using 2 self-drilling screws, plug connector to receptacle and secure the fan body to adaptor by using machine screw (M4X6). (Fig.14)

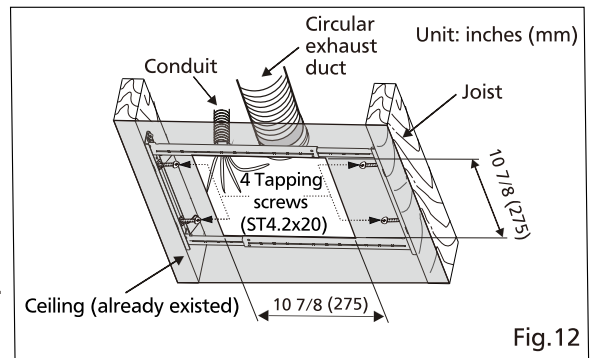

Fig.12

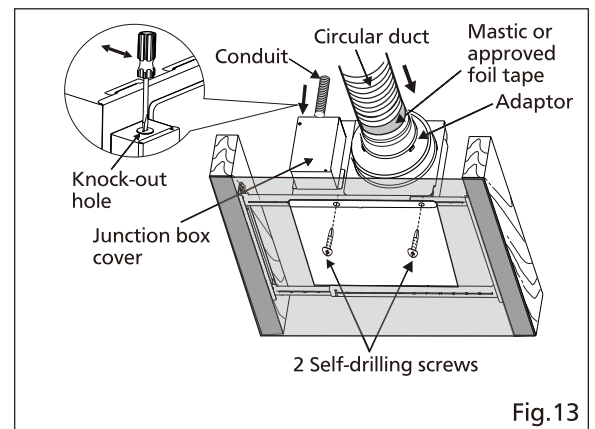

Fig.13

! CAUTION

! Secure the duct adaptor to the fan housing with the machine screw (M4X6) by re-inserting and carefully screwing the adaptor to the housing. Please insure the screw is appropriately placed so it does not strip the teeth nor come in contact with the Flex-Z Fast™ bracket.

5. Follow the step 10 to 13 on page 8.

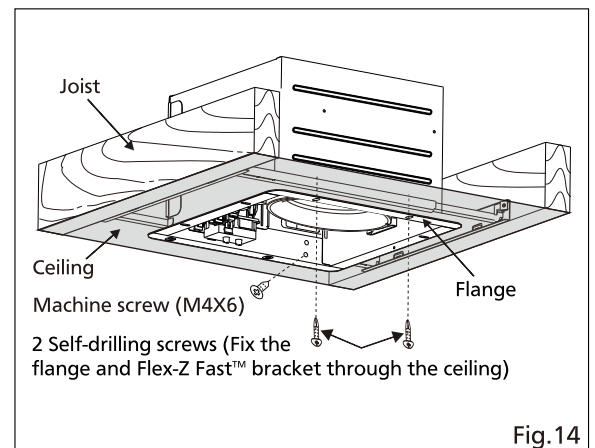





Fig.14

MAINTENANCE (CLEANING)

WARNING

 Disconnect power source before working on unit.

CAUTION

-  Routine maintenance must be done every year. Please wear gloves during the cleaning work.
-  Never use gasoline, benzene, thinner or any other such chemicals for cleaning the ventilating fan.
-  Do not immerse motor in water when cleaning. Do not soak resin parts in water over 140 °F (60 °C).

1. Remove grille. (Squeeze mounting springs and pull down carefully.)(Fig.15)

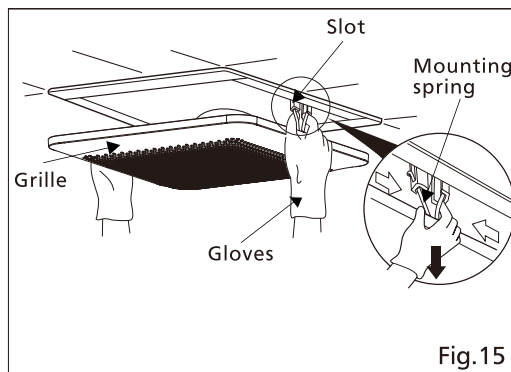

2. Wash and clean grille.(Don't put into hot water. Use non-abrasive kitchen detergent, wipe dry with clean cloth.)(Fig.16)

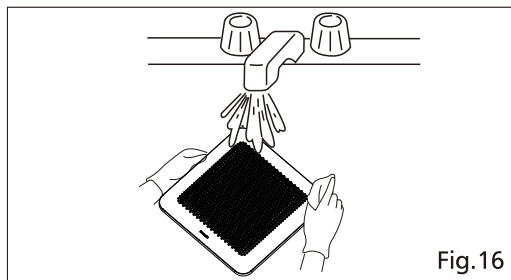

- 3.Remove dust and dirt from fan body using a vacuum cleaner. (Fig.17)
- 4.Using a cloth dampened with kitchen detergent remove any dirt from fan body. Wipe dry with clean cloth. (Fig.17)
5. Reinstall grille.

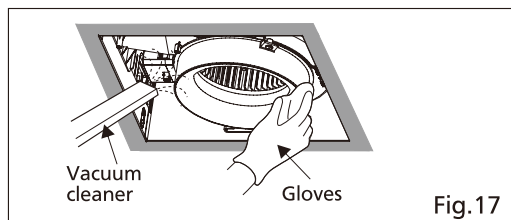

PRACTICAL GUIDE TO INSTALLATION

Properly insulate the area around the fan to minimize building heat loss and gain. (Fig.18)

Loose fill or batt insulation can be placed directly over the fan housing in the attic. Our fans and fan/light combination units do not create excessive heat that is a common problem with recessed light fixtures or some competitor's fan/light combination. Our efficient, cool-running motors and our LED lighting unit do not create enough ambient heat to be

subjected to these limitations. The ducting from this fan to the outside of the building has a strong effect on the air flow, noise and energy use of the fan. Use the shortest, straightest duct routing possible for best performance, and avoid installing the fan with smaller ducts than recommended. Insulation around the ducts can reduce energy loss and inhibit mold growth. Fans installed with existing ducts may not achieve their rated air flow.

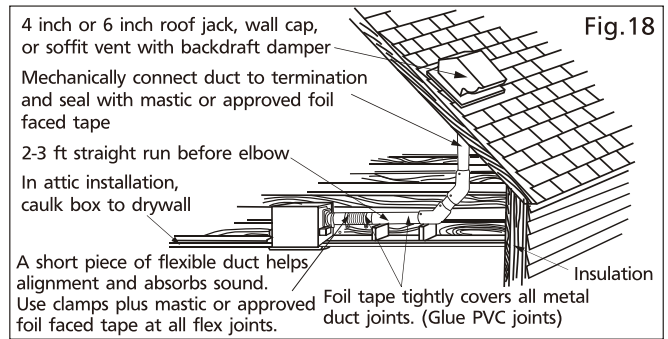

SPECIFICATIONS

Model No.	Air direction	Voltage (V)	Frequency (Hz)	Duct diameter (inches)	Air volume at 0.1" WG (CFM)	Noise (sones)	Speed (rpm)	Power (W)	Weight lb.(kg)
FV-0811RQ1	Exhaust	120	60	4	80	< 0.3	807	16.7	10.4 (4.7)
					110	0.4	945	21.5	
FV-1315RQ1	Exhaust	120	60	6	130	< 0.3	646	25.3	11.7 (5.3)
					150	0.3	690	27.7	

HVI Certified performance based on HVI Procedures 915, 916, and 920.

PRODUCT SERVICE

Warning Concerning Removal of Covers.

The unit should be serviced by qualified technicians only.

Your product is designed and manufactured to ensure a minimum of maintenance.

Should your unit require service or parts, call Panasonic Call Center at 1-866-292-7299 (USA)

Panasonic Corporation of North America

Two Riverfront Plaza, Newark, NJ 07102

www.panasonic.com