

F05G921&F05G922

4-Piece Conversation Set

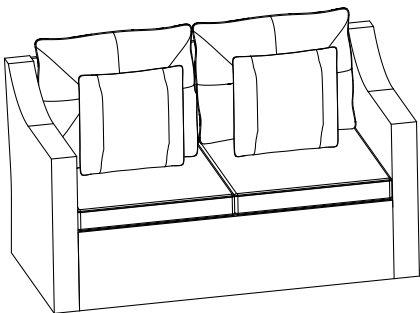

X1

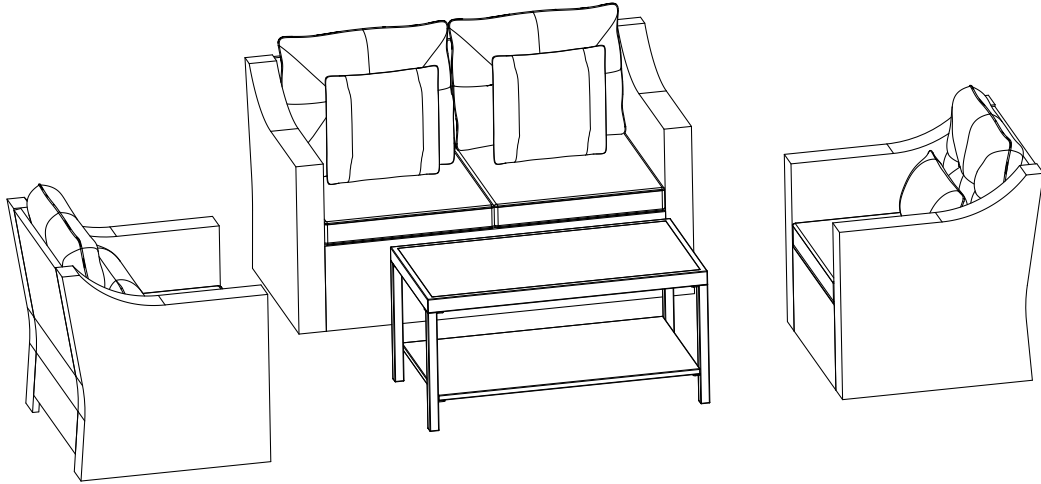
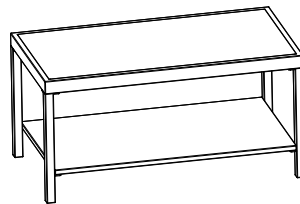

X1

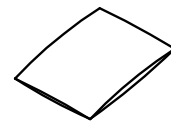

Assembly
bag



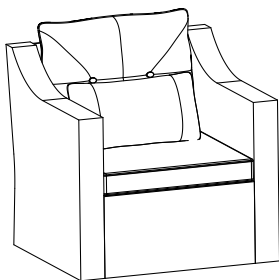





CARTON 1/2

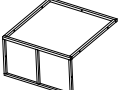

X2

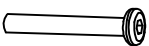
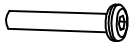
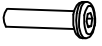
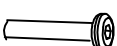
CARTON 2/2

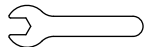
F05G921&F05G922**DO THIS TWICE**

Item no.	Reference Image	Description	Qty.
A		Right Arm Rest	1
B		Left Arm Rest	1
C		Seat Back	1
D		Seat Base	1
E		Bracket	2
F		M6 x 60 Head Cap Screw	4
G		M6 x 50 Head Cap Screw	6
H		M6 x 20 Head Cap Screw	4
I		M6 x 40 Head Cap Screw	1
J		Nut	10
K		Washer	25
L		Wrench	1
M		Allen Key	1
N		Leveler	4

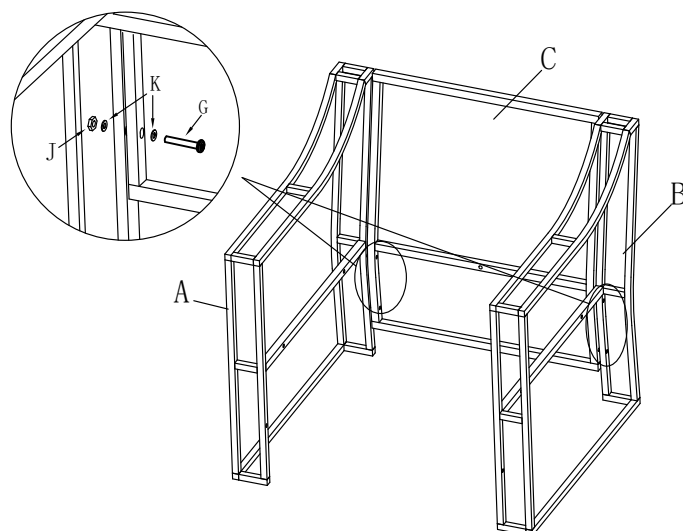
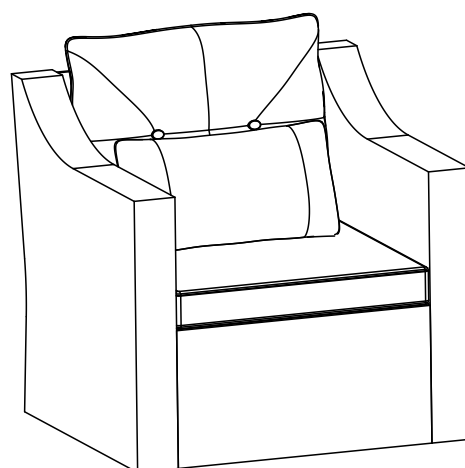
**1**

Fix the seat back (C) to the left and right arm (A&B) by threading head cap screws (G) with washers (K) through the furniture and securing into place with washers (K) and nut (J). Tighten into place with wrench (L) and allen key (M). Do this in four places.

F05G921&F05G922**DO THIS TWICE****2**

Fix the seat base (D) to the assembly by threading head cap screws (F) with washers (K) through the furniture and securing into place with washers (K) and nut (J). Tighten into place with wrench (L) and allen key (M). Do this in four places.

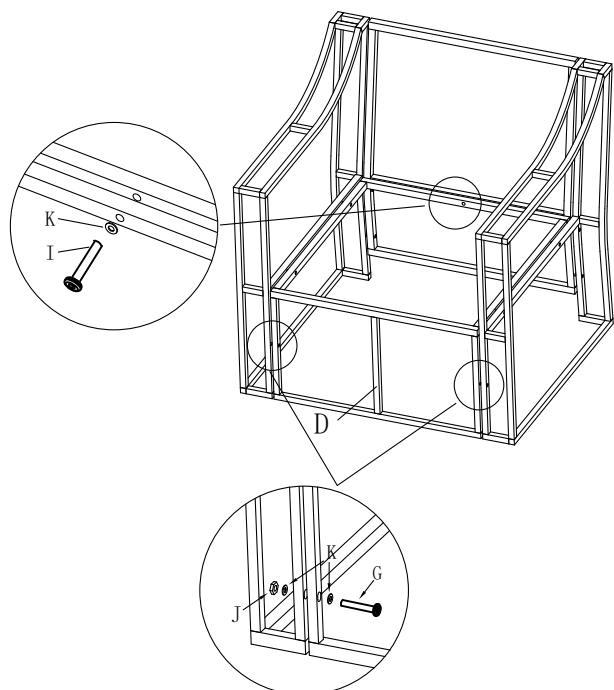
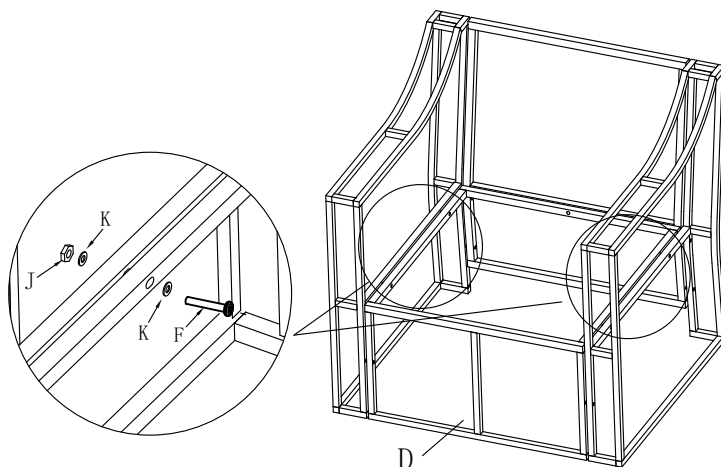
**3**

Fix the lower holes of the seat base (D) to the left and right arm (A&B) by threading head cap screws (G) with washers (K) through the furniture and securing into place with washers (K) and nut (J). Tighten into place with wrench (L) and allen key (M). Do this in two places.

Fix the middle back hole of the seat base (D) to the seat back (C) by securing a head cap screw (I) with a washer (K).

4





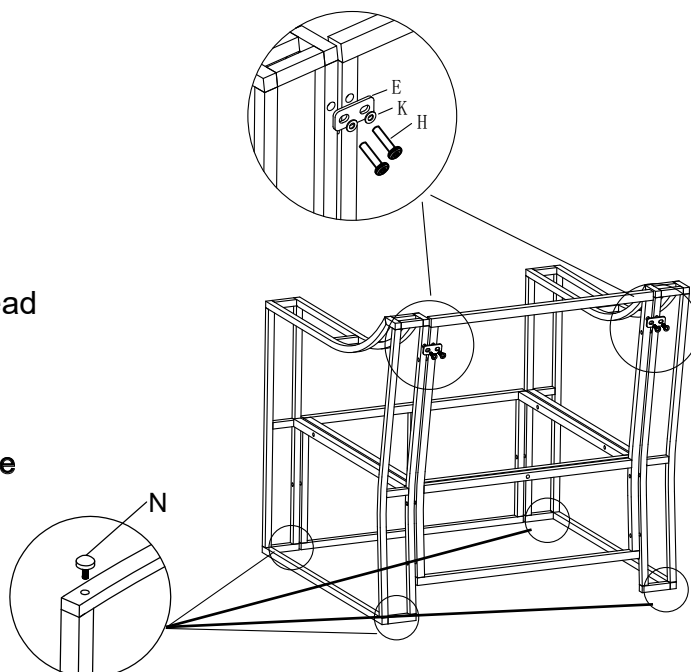



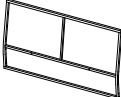
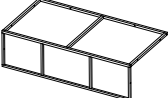

Fix the seat back (C) to the left and right arm (A&B) by securing brackets (E) with head cap screws (H) and washers (K). Do this in two places.

Fix the levelers (N) to the seat back (C) and the levels (N) to the arm rest (A&B). Do this in four places.

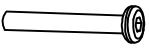
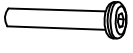
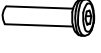
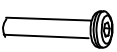

F05G921&F05G922

Bench

Item no.	Reference Image	Description	Qty.
A		Right Arm Rest	1
B		Left Arm Rest	1
C		Seat Back	1
D		Seat Base	1
E		Bracket	2
F		M6 x 60 Head Cap Screw	4
G		M6 x 50 Head Cap Screw	6
H		M6 x 20 Head Cap Screw	4
I		M6 x 40 Head Cap Screw	2
J		Nut	10
K		Washer	26
L		Wrench	1
M		Allen Key	1
N		Leveler	4

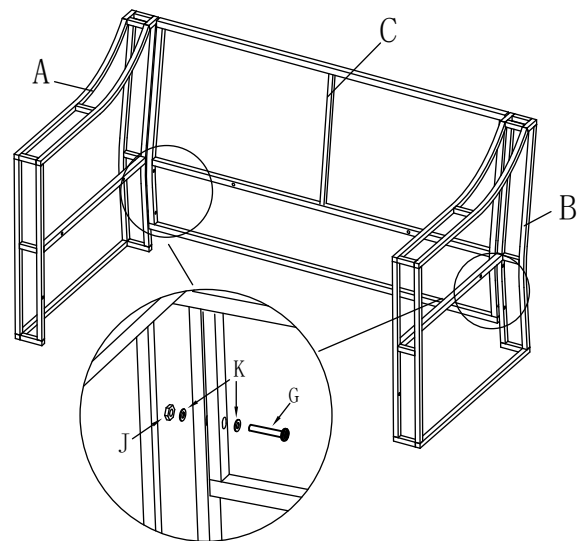
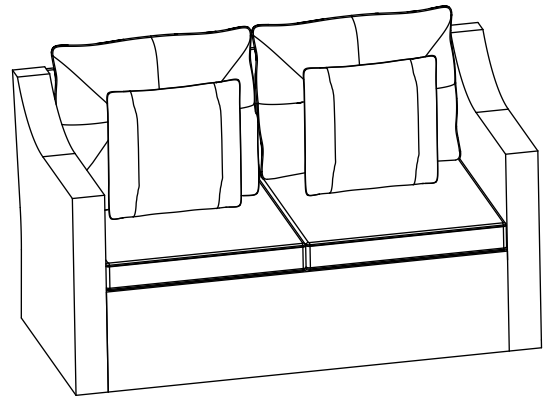

1

Fix the seat back (C) to the left and right arm (A&B) by threading head cap screws (G) with washers (K) through the furniture and securing into place with washers (K) and nut (J). Tighten into place with wrench (L) and allen key (M). Do this in four places.

F05G921&F05G922

Bench

2

Fix the seat base (D) to the assembly by threading head cap screws (F) with washers (K) through the furniture and securing into place with washers (K) and nut (J). Tighten into place with wrench (L) and allen key (M). Do this in four places.

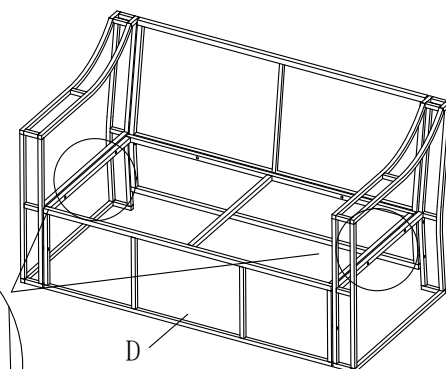
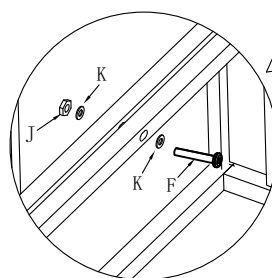

3

Fix the lower holes of the seat base (D) to the left and right arm (A&B) by threading head cap screws (G) with washers (K) through the furniture and securing into place with washers (K) and nut (J). Tighten into place with wrench (L) and allen key (M). Do this in two places.

Fix the middle back hole of the seat base (D) to the seat back (C) by securing a head cap screw (I) with a washer (K). Do this in two places.

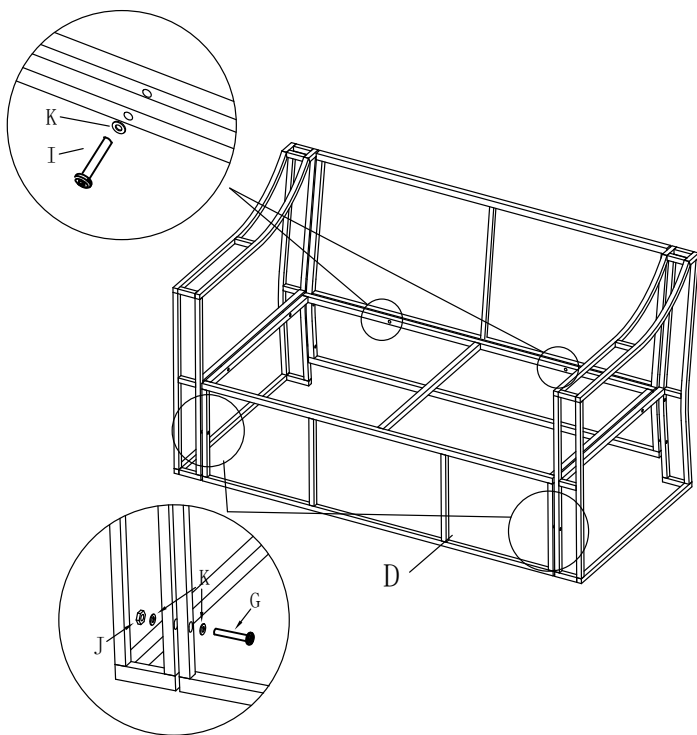

4



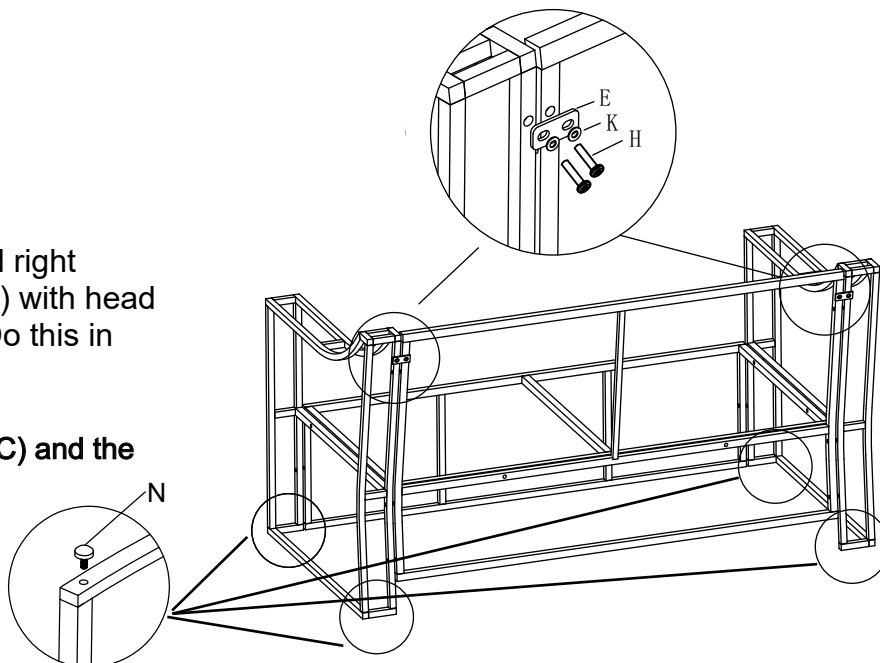

Fix the seat back (C) to the left and right arm (A&B) by securing brackets (E) with head cap screws (H) and washers (K). Do this in two places.

Fix the levelers (N) to the seat back (C) and the levels (N) to the arm rest (A&B). Do this in four places.

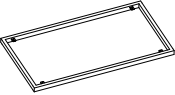
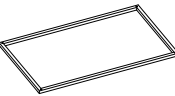
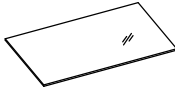
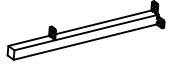

F05G921&F05G922

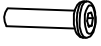
Table

Item no.	Reference Image	Description	Qty.
A		Table Top	1
B		Base	1
C		Glass	1
D		Leg 1	2
E		Leg 2	2
H		M6 x 20 Head Cap Screw	12
K		Washer	12
M		Allen Key	1

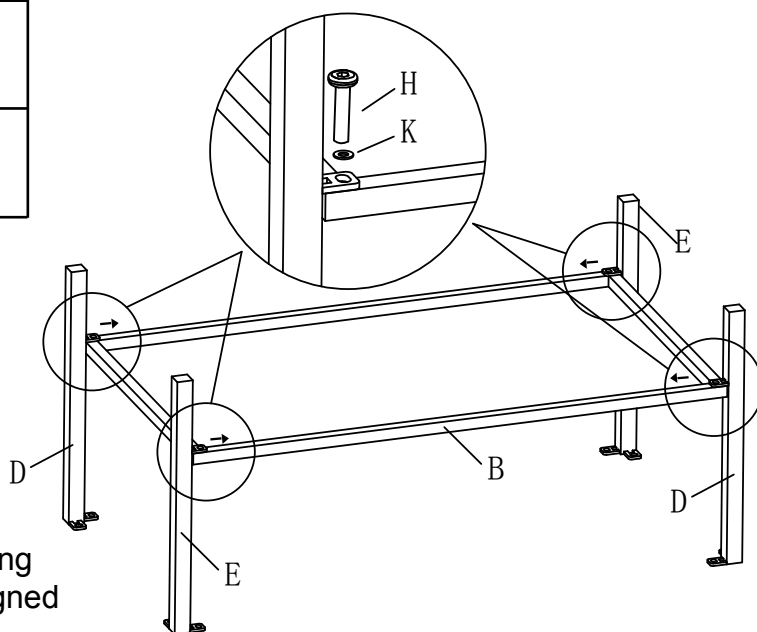
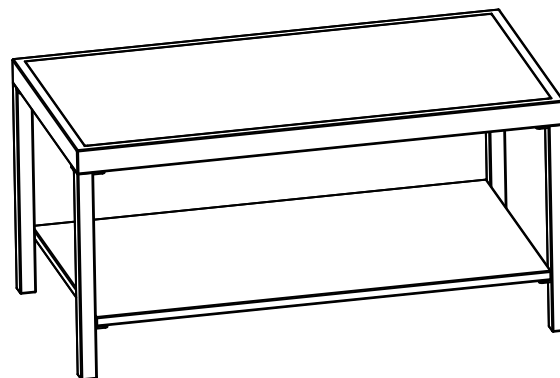

1

Fix the legs (D&E) to the base (B) by securing with head cap screws (H) and washers (K). Note: Make sure the connecting bar on the legs (D & E) needs to be put aligned with the long side of the base (B) (see the detail in circle on the drawing) Do this in four places.

F05G921&F05G922 Table

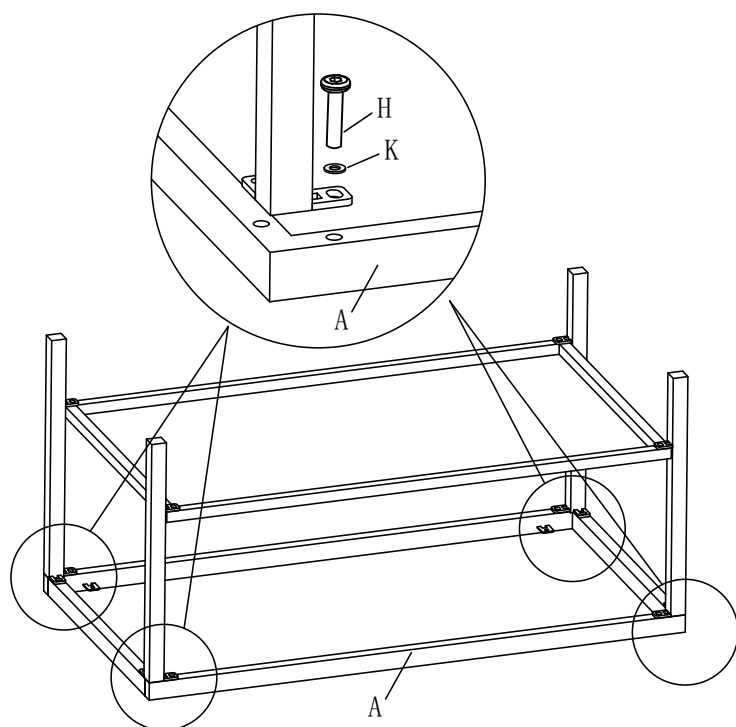
**2**

Fix the table top (A) to the legs (D&E) by securing head cap screws (H) with washers (K).

3

Flip assembly over and insert glass (C).

