

South  Shore

ASSEMBLY INSTRUCTIONS  
INSTRUCTIONS D'ASSEMBLAGE  
INSTRUCTIVO DE ARMADO



Article/ Item/ Artículo

**-011-** Dresser  
Bureau  
Comoda



 1-800-290-0465 



MUST BE ASSEMBLED BY TWO ADULTS  
**DOIT ÊTRE ASSEMBLÉ PAR DEUX ADULTES**  
DEBE SER ENSAMBLADO POR DOS ADULTAS

**#Instructions/ #Instructions/ #Instructivo**

**#10028066**

## WARNING

**Serious or fatal crushing injuries can occur from furniture tip-over. To help prevent tip-over :**

- Place heaviest items in the lowest drawers.
- Do not set TVs or other heavy objects on the top of this product. Never allow children to climb or hang on drawers, doors, or shelves.
- Never open more than one drawer at a time.

**Use of tip-over restraints, only reduces, but does not eliminate, the risk of tip-over.**

## AVERTISSEMENT

**Des blessures graves ou fatales peuvent résulter du basculement du meuble.**

**Afin d'éviter le basculement :**

- Placer les items les plus lourds dans les tiroirs du bas.
- Ne placer pas de TV ou d'autres objets lourds sur ce produit. Ne jamais laisser un enfant grimper sur les tiroirs, les portes et les tablettes ou s'accrocher à ceux-ci.
- Ne jamais ouvrir plus d'un tiroir à la fois.

**L'utilisation de dispositif anti-basculement ne peut que réduire les risques de basculement, sans les éliminer totalement.**

## ADVERTENCIA

**El volcadura del mueble puede ser causa de lesiones graves o de un atropellamiento fatal.**

**Para evitar la volcadura :**

- Ponga las cosas pesadas en los cajones mas bajos.
- No ponga televisores u otros objetos pesados encima de este producto. Nunca permita que un niño se suba o se cuelgue en cajones, puertas o estantes.
- Nunca abra mas de un cajon a la vez.

**El uso de sujetadores para evitar la volcadura solo puede disminuir el riesgo de una volcadura, pero no lo elimina.**

**-011-**

Assembly order:  
*Ordre d'assemblage:*  
Orden de ensambladura:  
1:Box/*Boîte*/Caja #1  
2:Box/*Boîte*/Caja #2

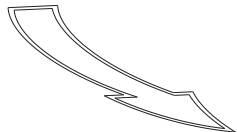
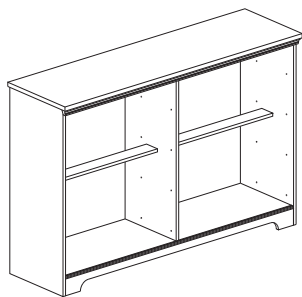

RIGHT SIDE  
CÔTÉ DROIT  
LADO DERECHO

Box/*Boîte*/Caja #2

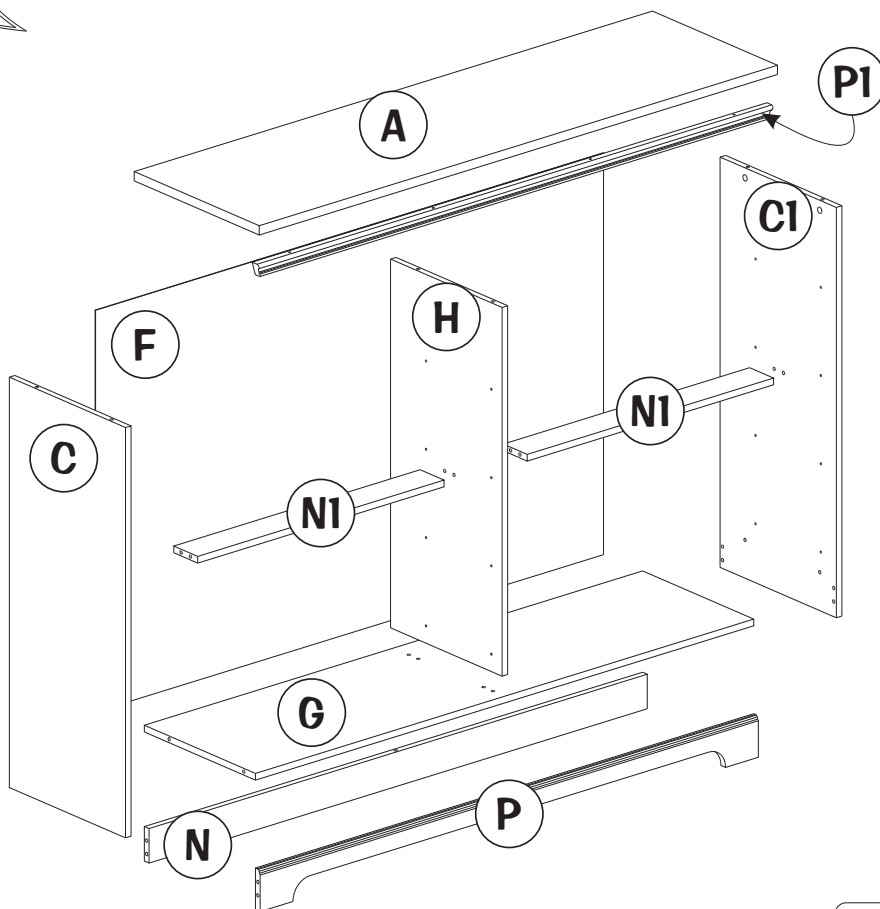

LEFT SIDE  
CÔTÉ GAUCHE  
LADO IZQUIERDO

Box/*Boîte*/Caja #1

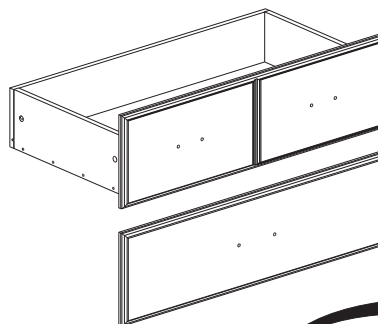
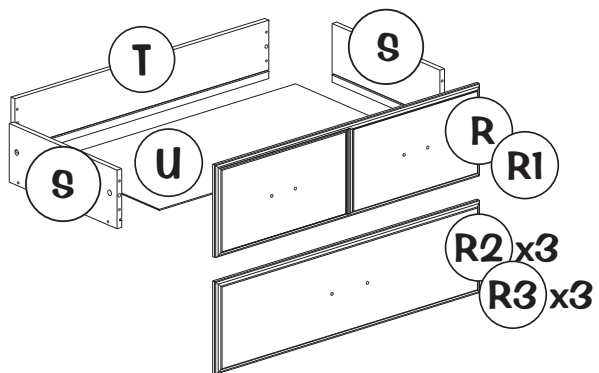

**8x** Drawers  
Tiroirs  
Cajones



**N.B.: It is important to carefully read all instructions before beginning the assembly and before use of the furniture.**  
Keep the assembly instructions for future use and for warranty purposes.

**N.B. Il est important de bien lire toutes les instructions avant de commencer l'assemblage et avant d'utiliser le meuble.**  
Gardez les instructions d'assemblage pour utilisation future et pour la garantie.

**N.B. Lea con detenimiento las instrucciones antes de comenzar a ensamblar y antes de utilizar su mueble.**  
Guarde el instructivo de ensamble para un futuro uso y para usos de garantía.

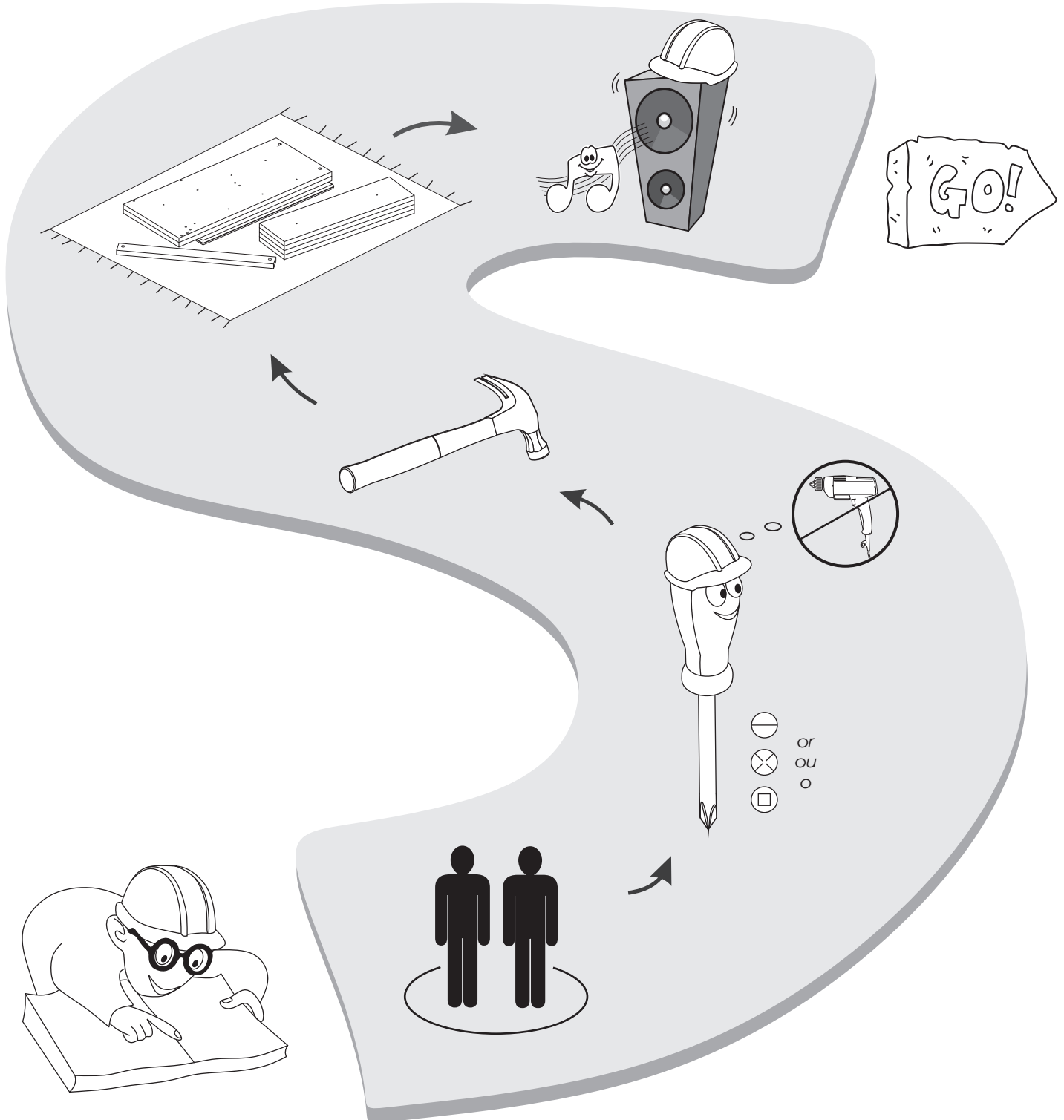

**\*\*\*THINGS TO REMEMBER FOR ASSEMBLY/ À RETENIR LORS DE L'ASSEMBLAGE/ A RECORDAR DURANTE EL ENSAMBLAJE\*\*\***

\*\*\*THINGS TO REMEMBER FOR ASSEMBLY/ À RETENIR LORS DE L'ASSEMBLAGE/ A RECORDAR DURANTE EL ENSAMBLAJE\*\*\*

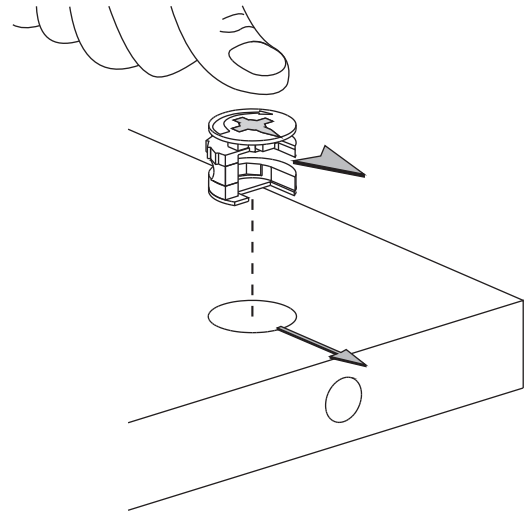
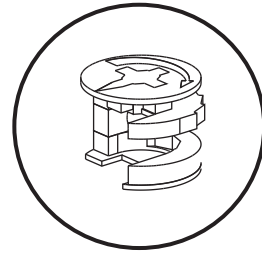
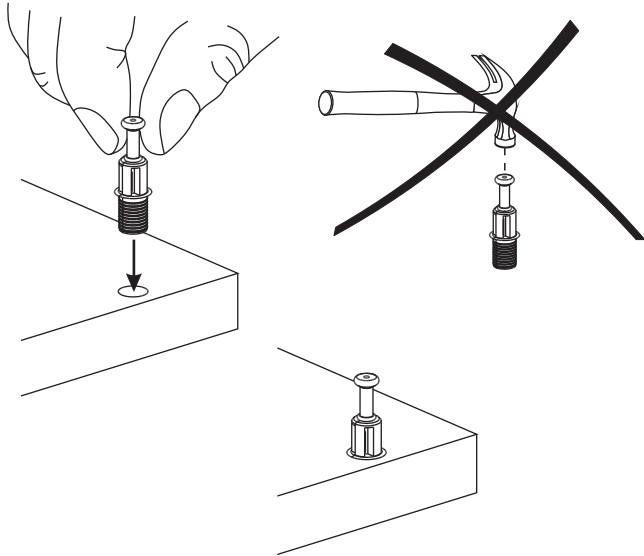
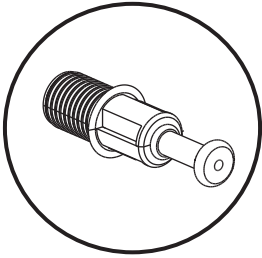

-To remove: Twist and pull  
-Pour enlever: Tourner et tirer

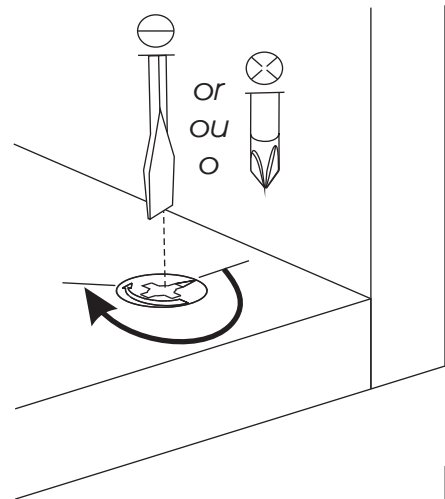
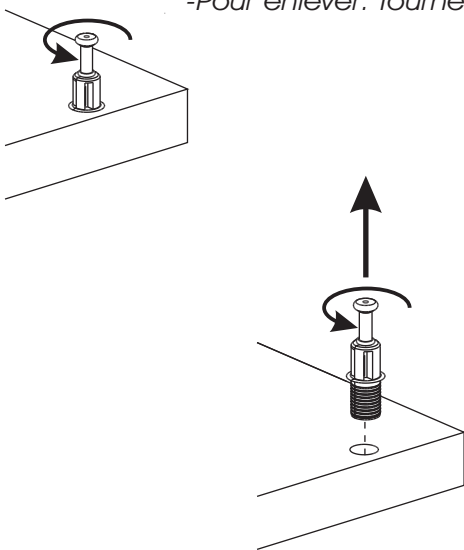

-Screw pass the half way point  
-Visser plus qu'un demi tour

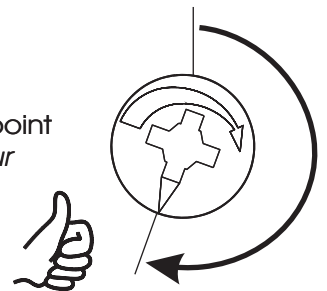

# HARDWARE (full scale)

# QUINCAILLERIE (taille réelle)

# HERRAJE (de tamaño real)

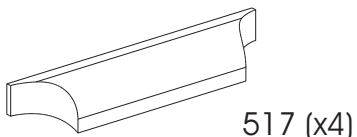
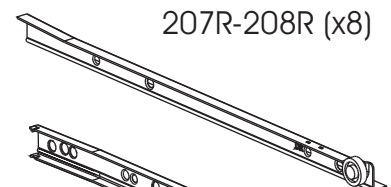
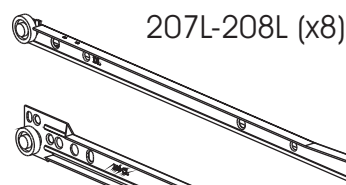
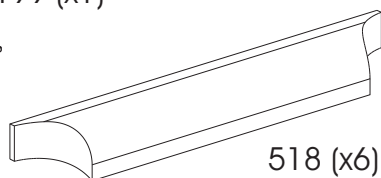
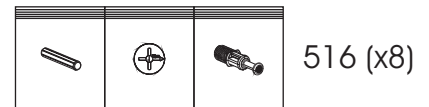
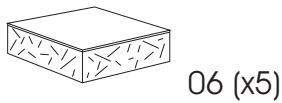
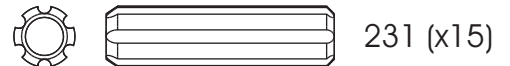
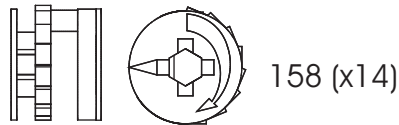
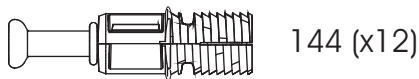
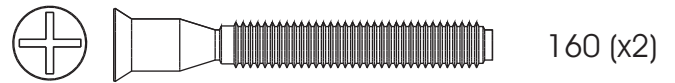
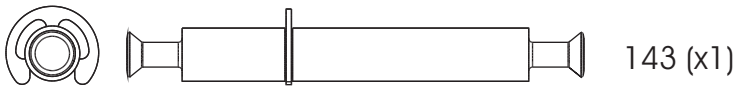
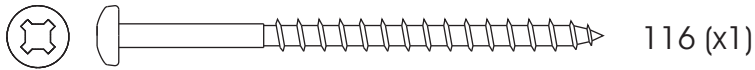
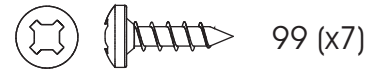

\* Hardware package may have spare parts .

\* Le sac de quincaillerie peut contenir des pièces de remplacement .

\* La bolsa de herraje puede contener piezas adicionales de repuesto .

1

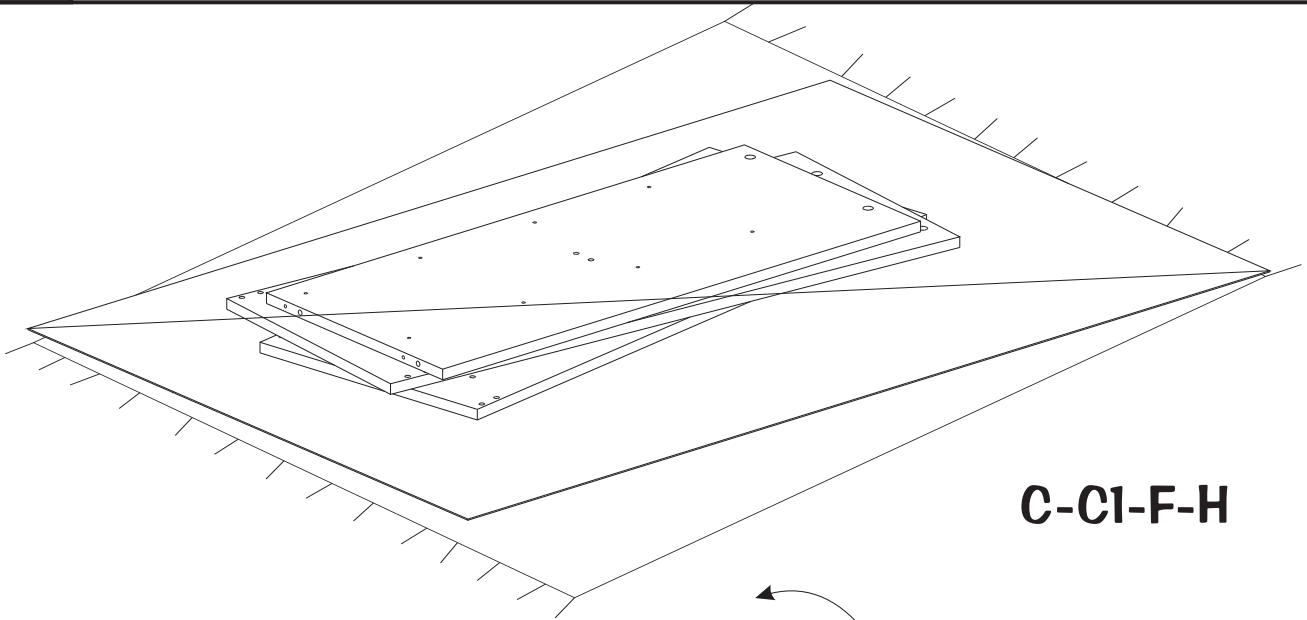
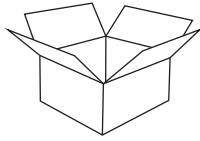

C-C1-F-H

Box/Boîte/Caja #2

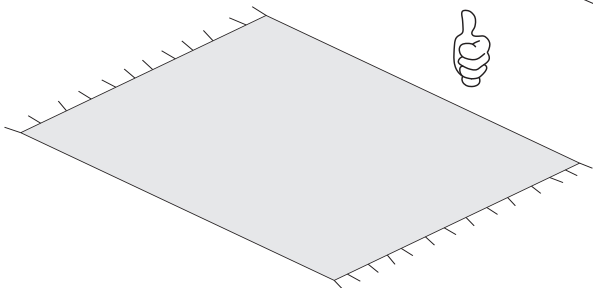
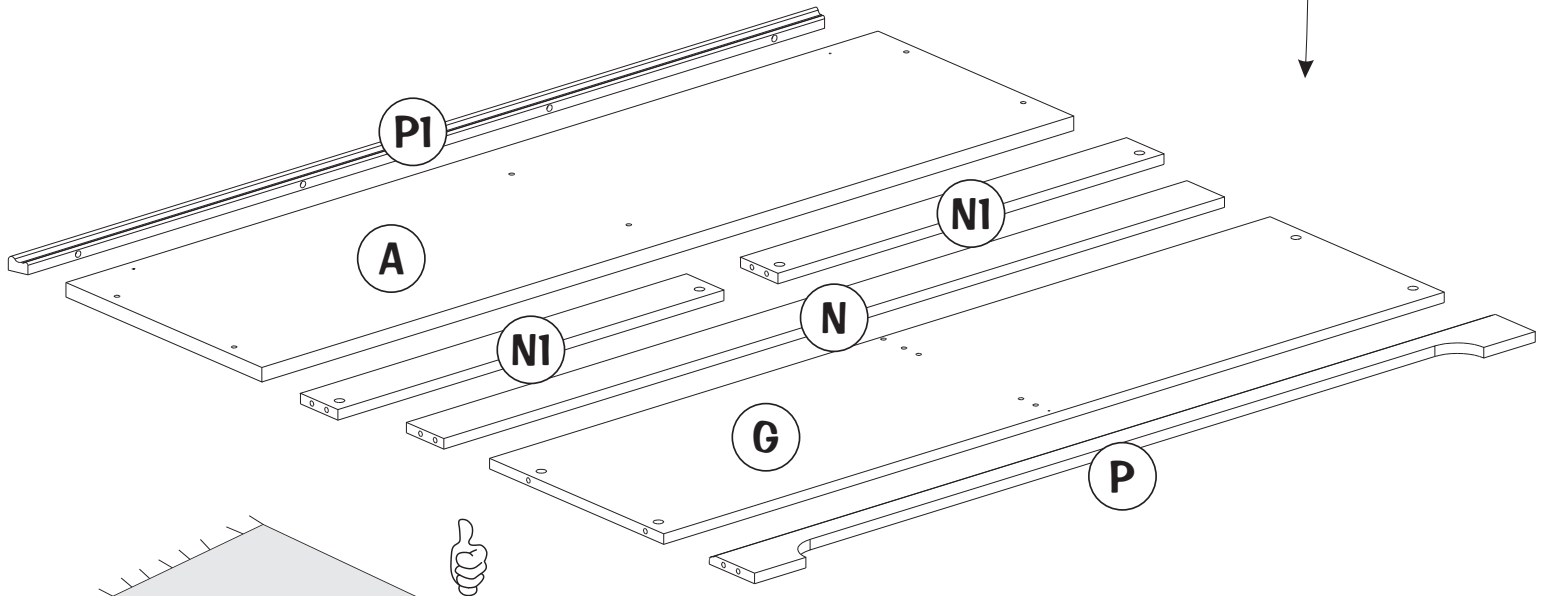
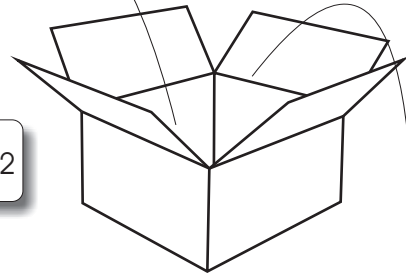

# 2



92 (x16)

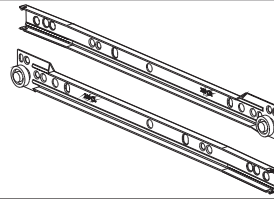

207L-207R (x4)

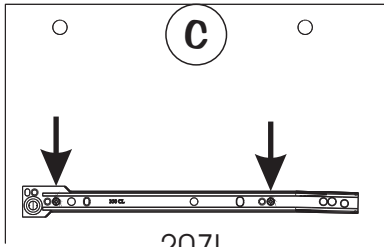

207L

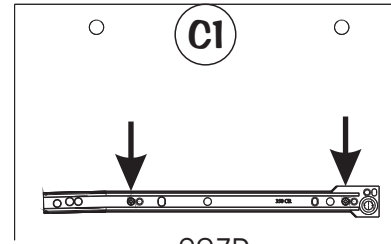
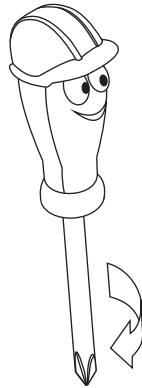

207R

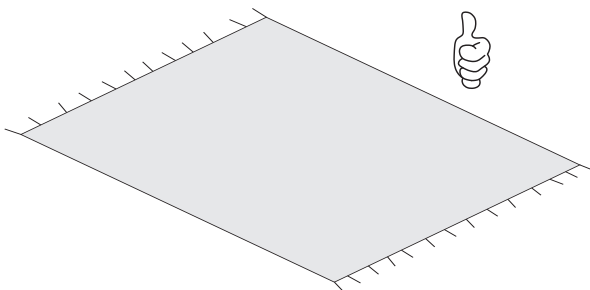
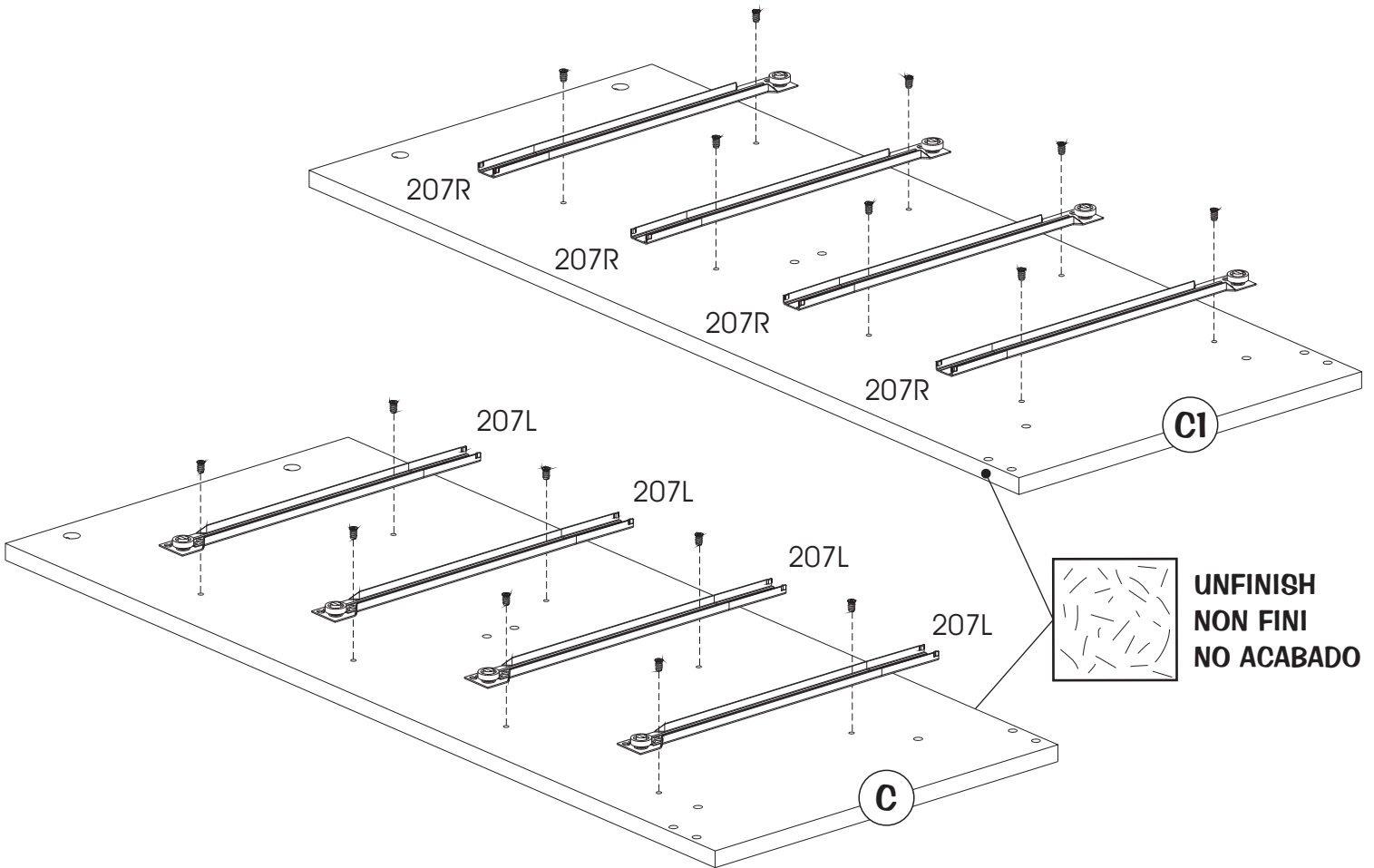



# 3

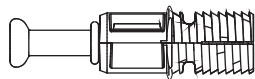

144 (x6)

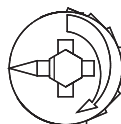
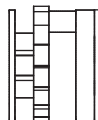

158 (x4)

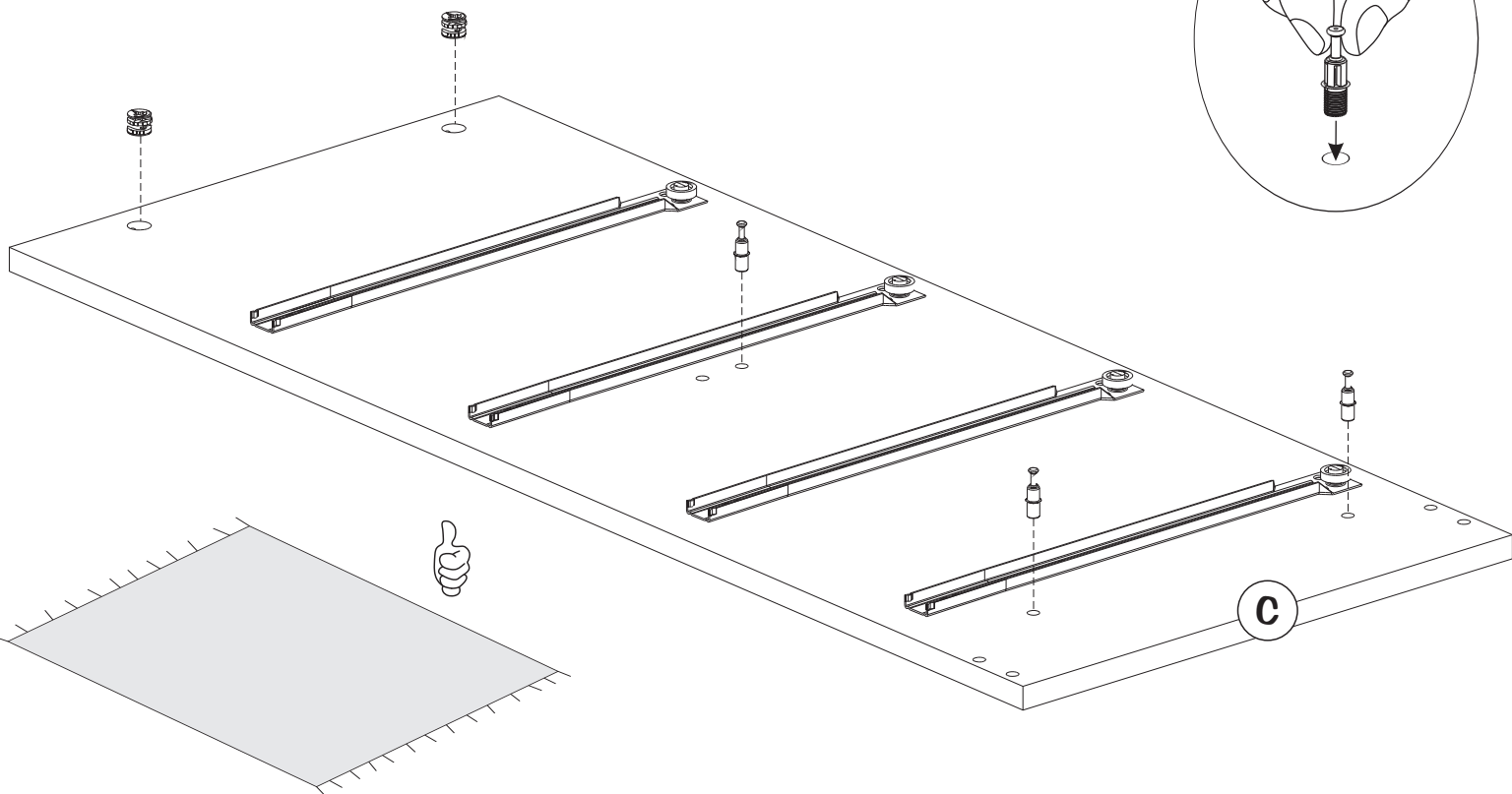
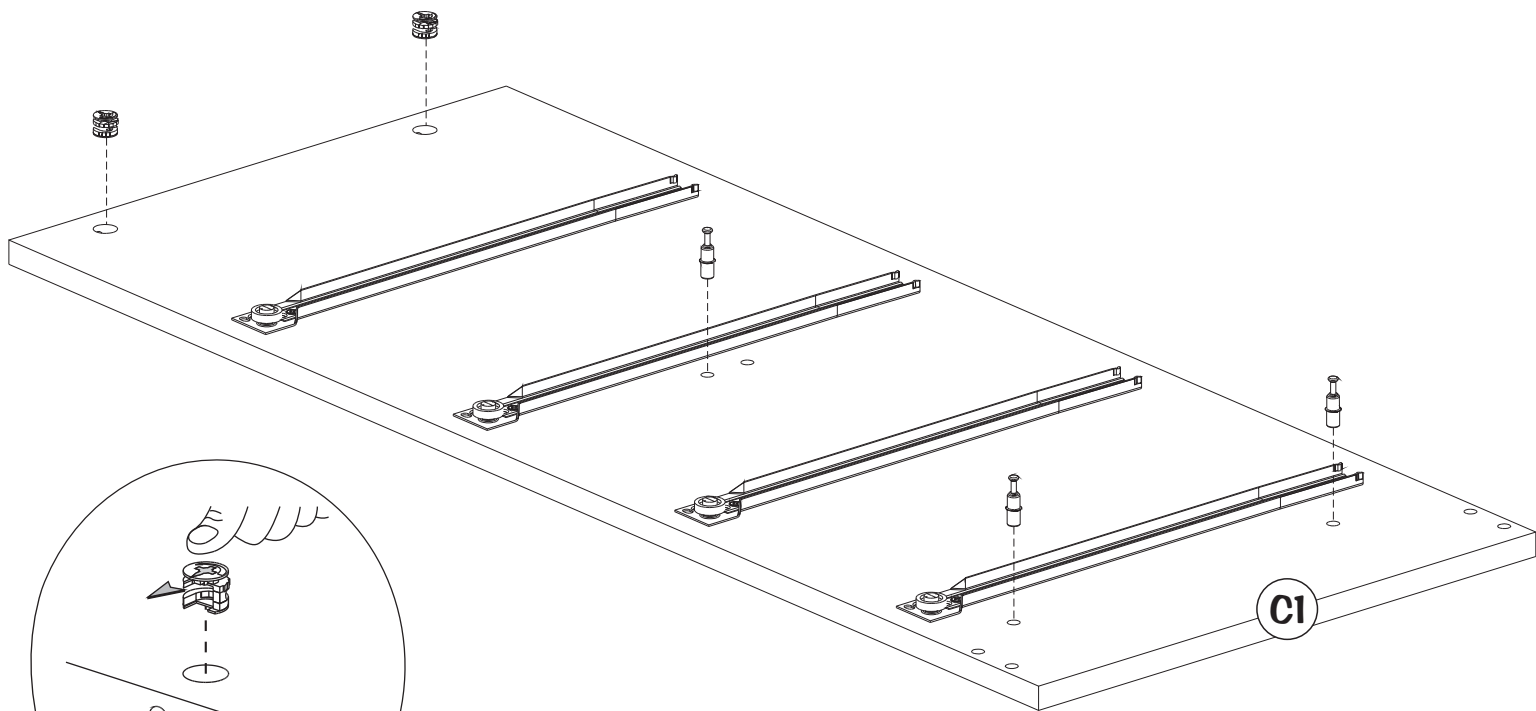

# 4

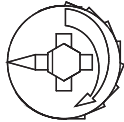
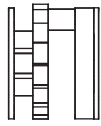

158 (x2)



92 (x16)

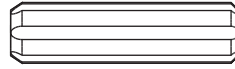

231 (x2)

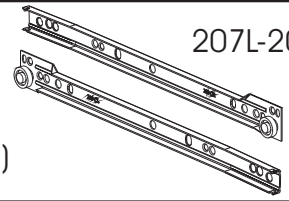

207L-207R (x4)

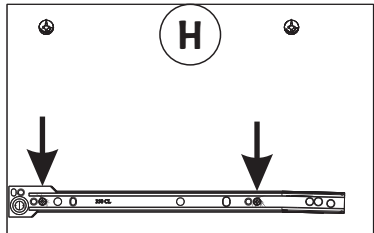

207L

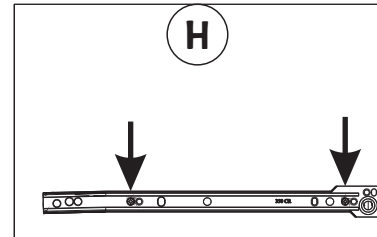
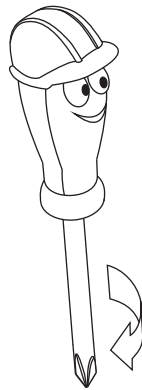

207R

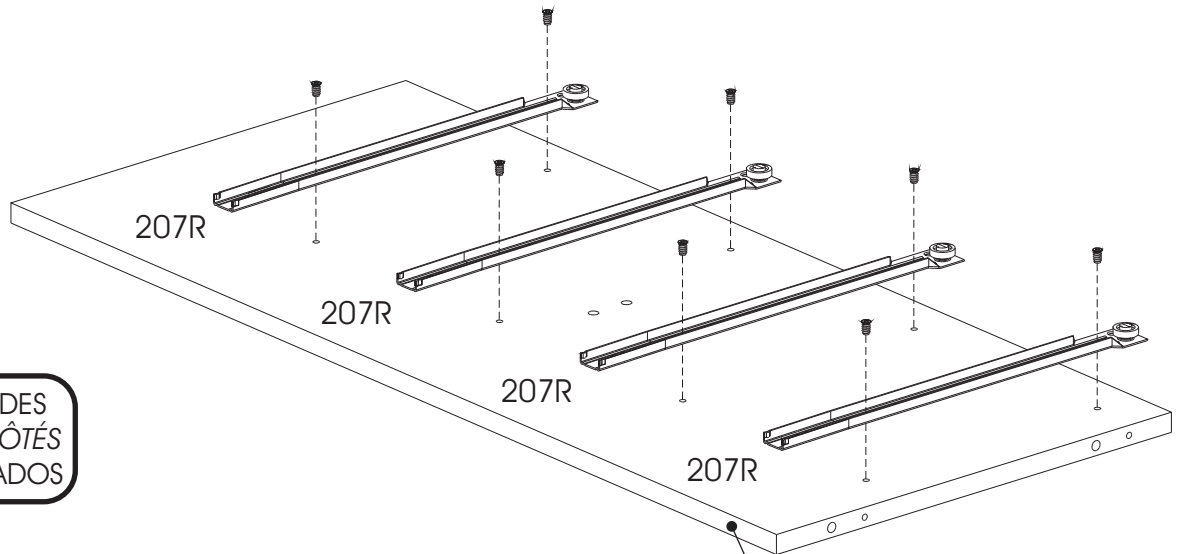

207R

207R

207R

207R

H

SAME PIECE - 2 SIDES  
MÊME PIÈCE - 2 CÔTÉS  
MISMO PIEZA - 2 LADOS

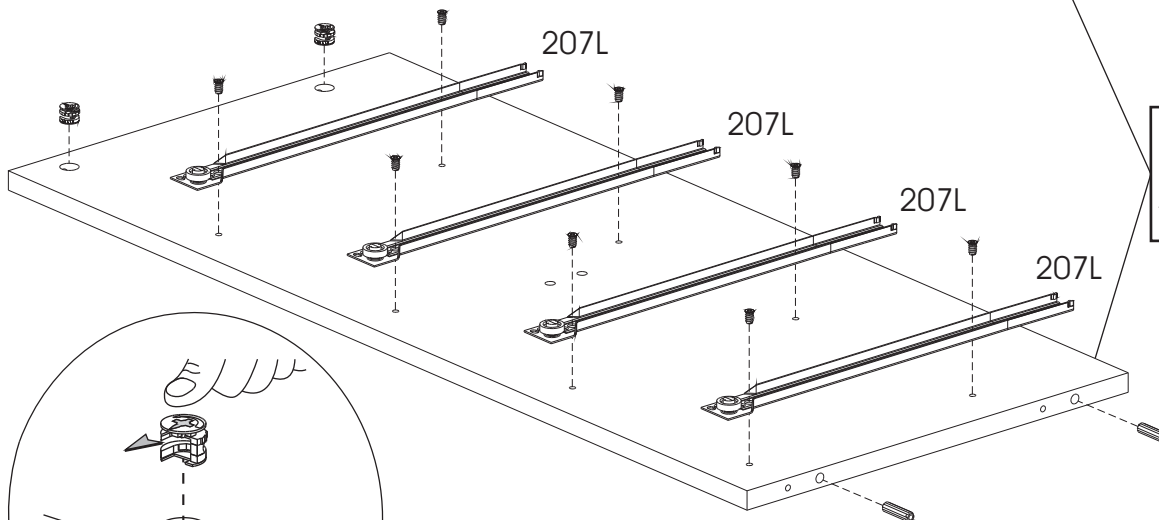

207L

207L

207L

207L

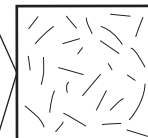

UNFINISH  
NON FINI  
NO ACABADO

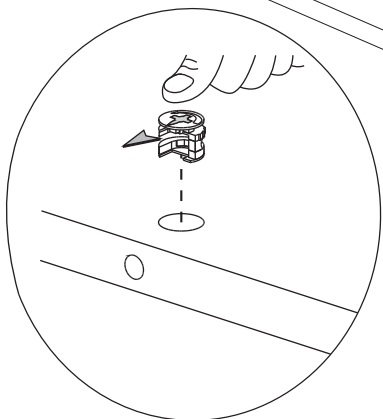

5

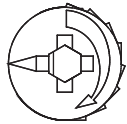
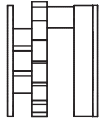

158 (x8)

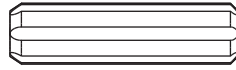

231 (x13)

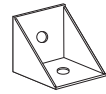

191 (x1)

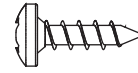

99 (x1)

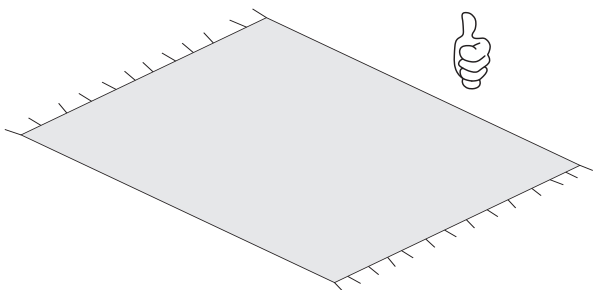
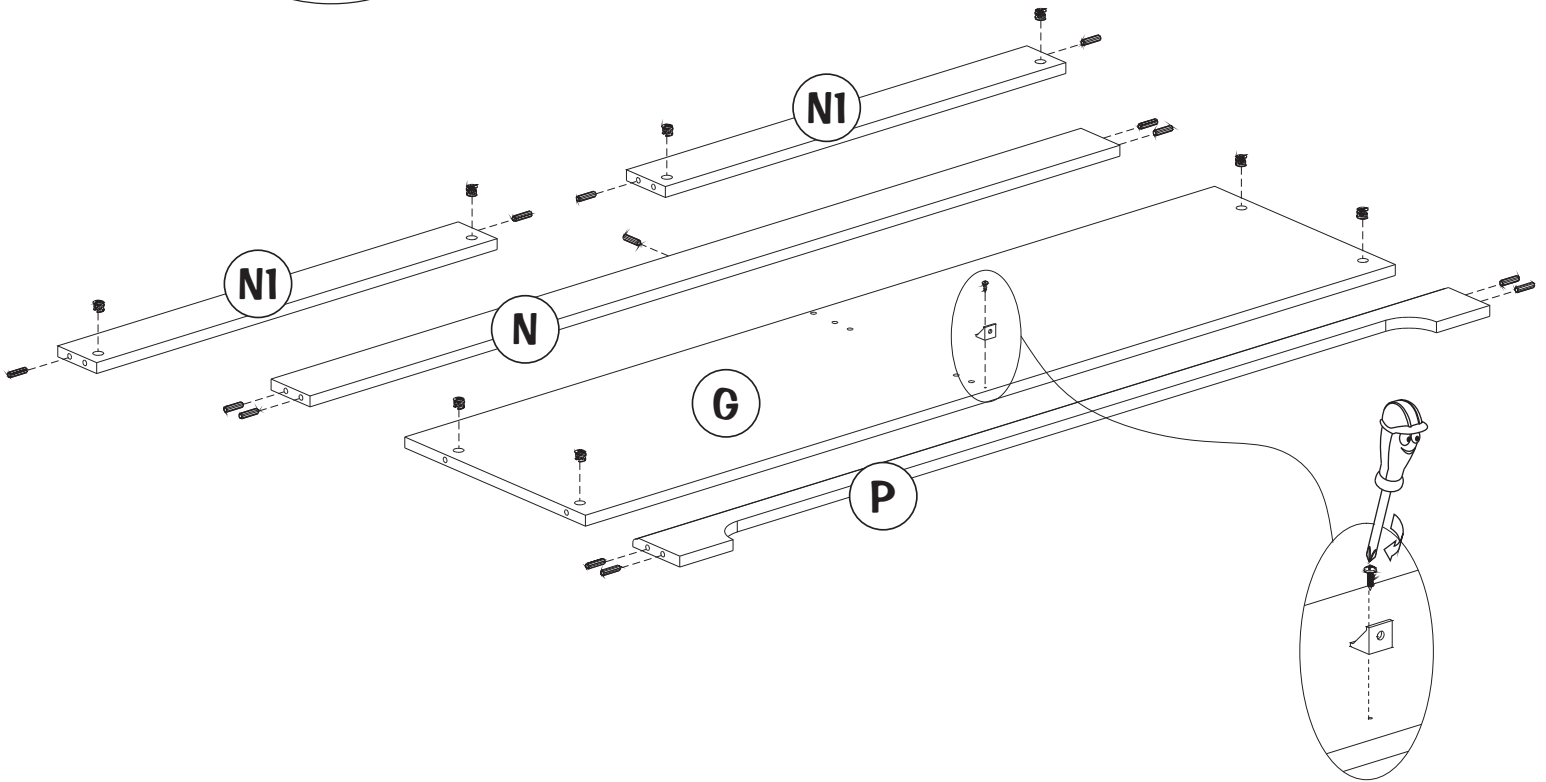
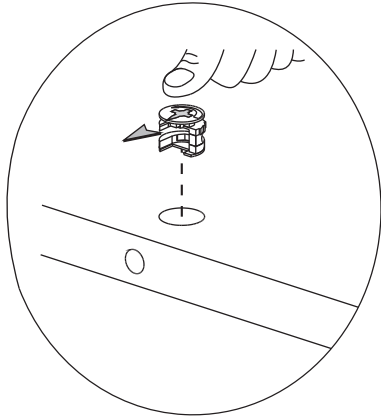

6

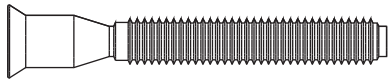

160 (x2)

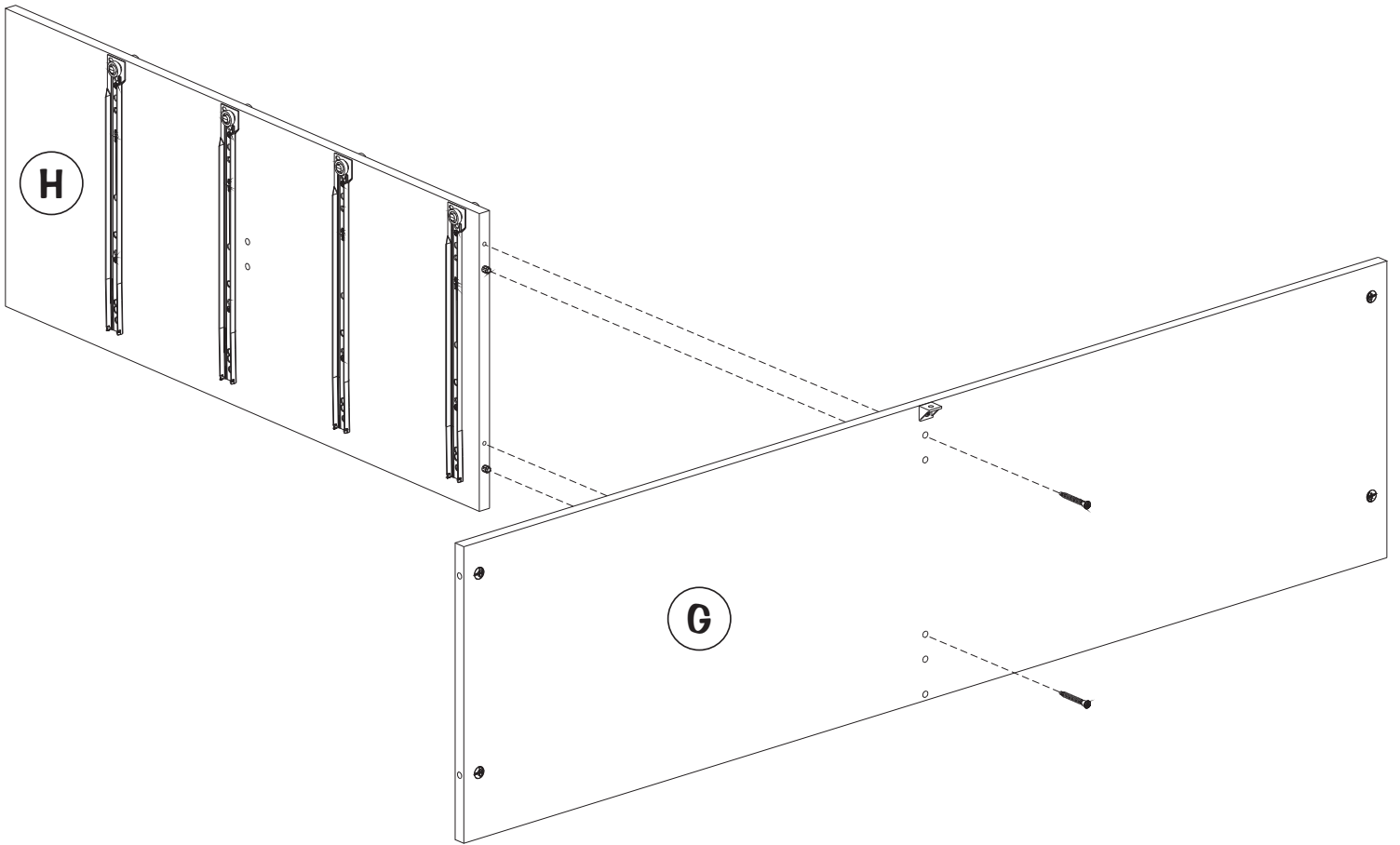
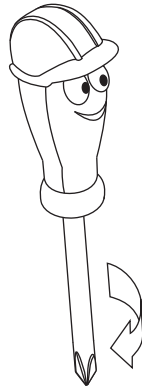

7

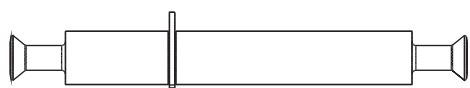

143 (x1)

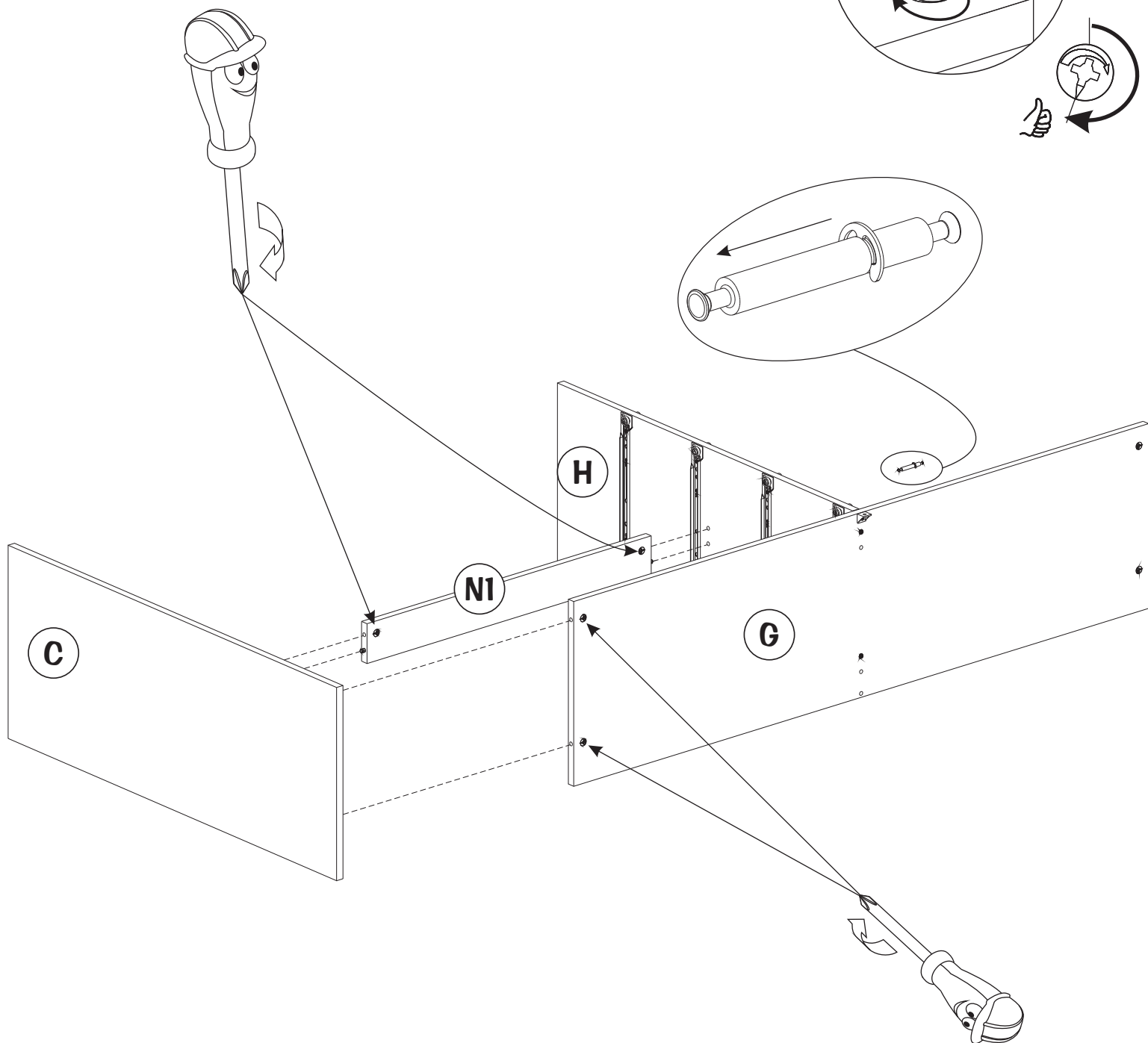
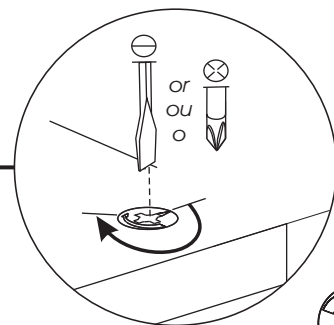

# 8

## ASSEMBLY / ASSEMBLAGE / ARMADO

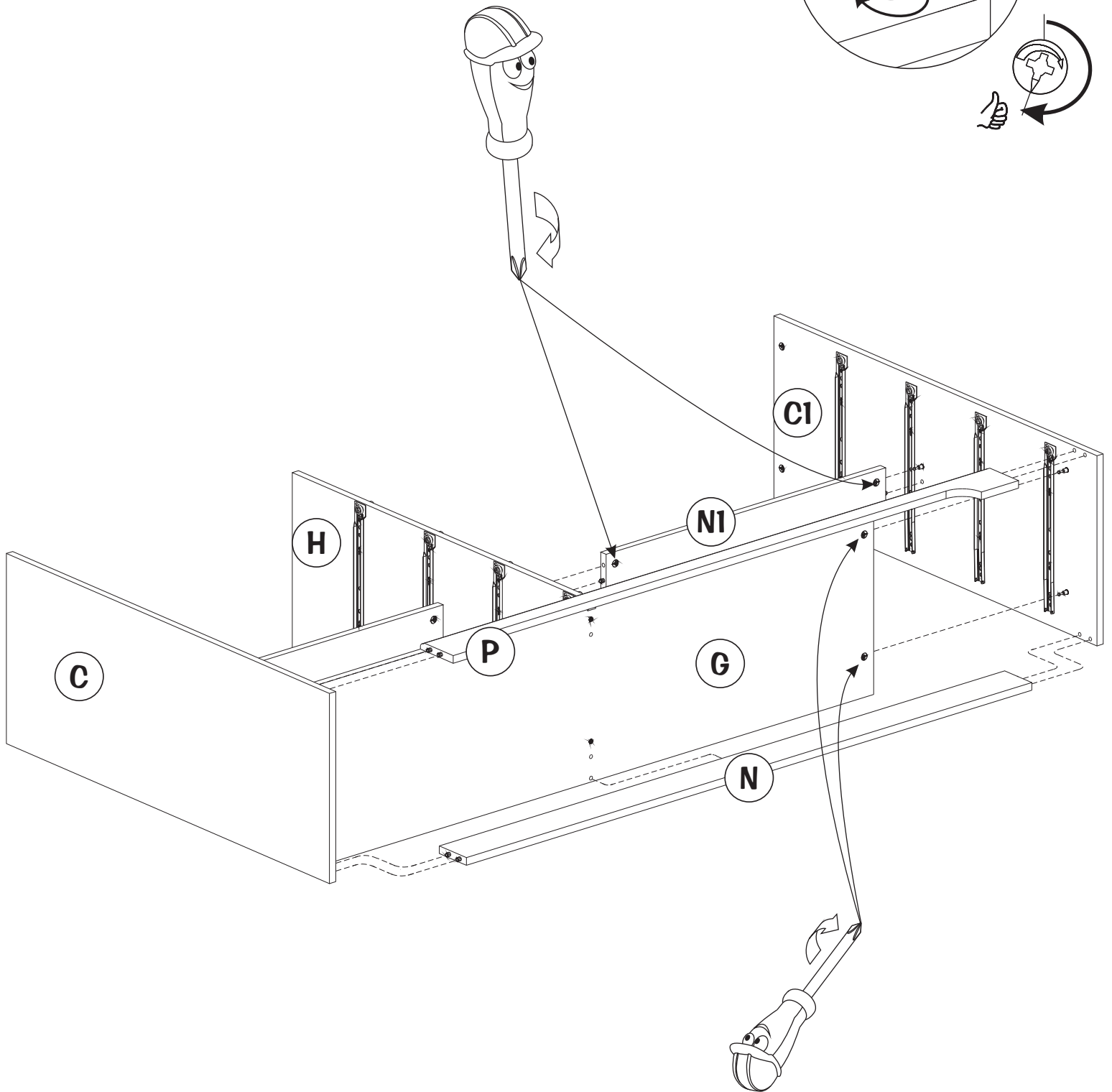
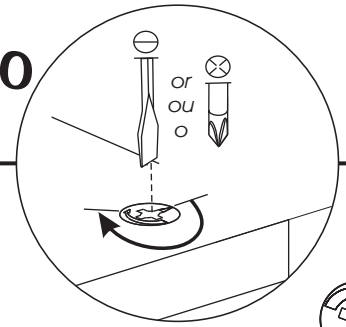

# 9

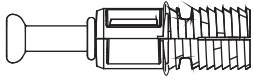

144 (x6)

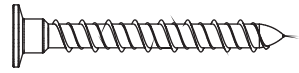

299 (x4)

## #1

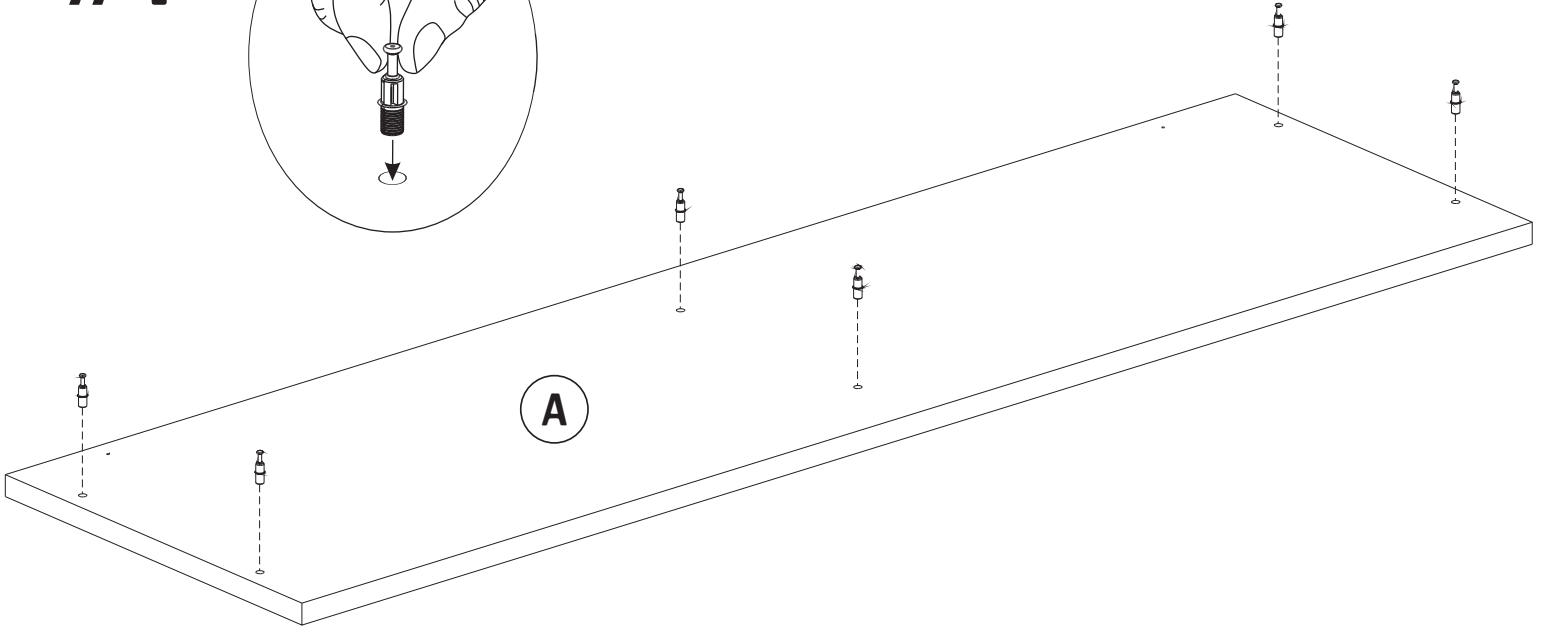
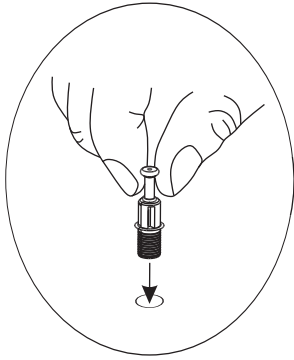

## #2

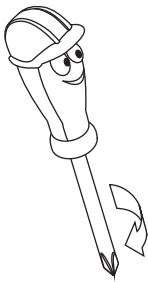

2 not pre-drilled holes  
2 trous non pré-perçés  
2 orificio no preagujereado

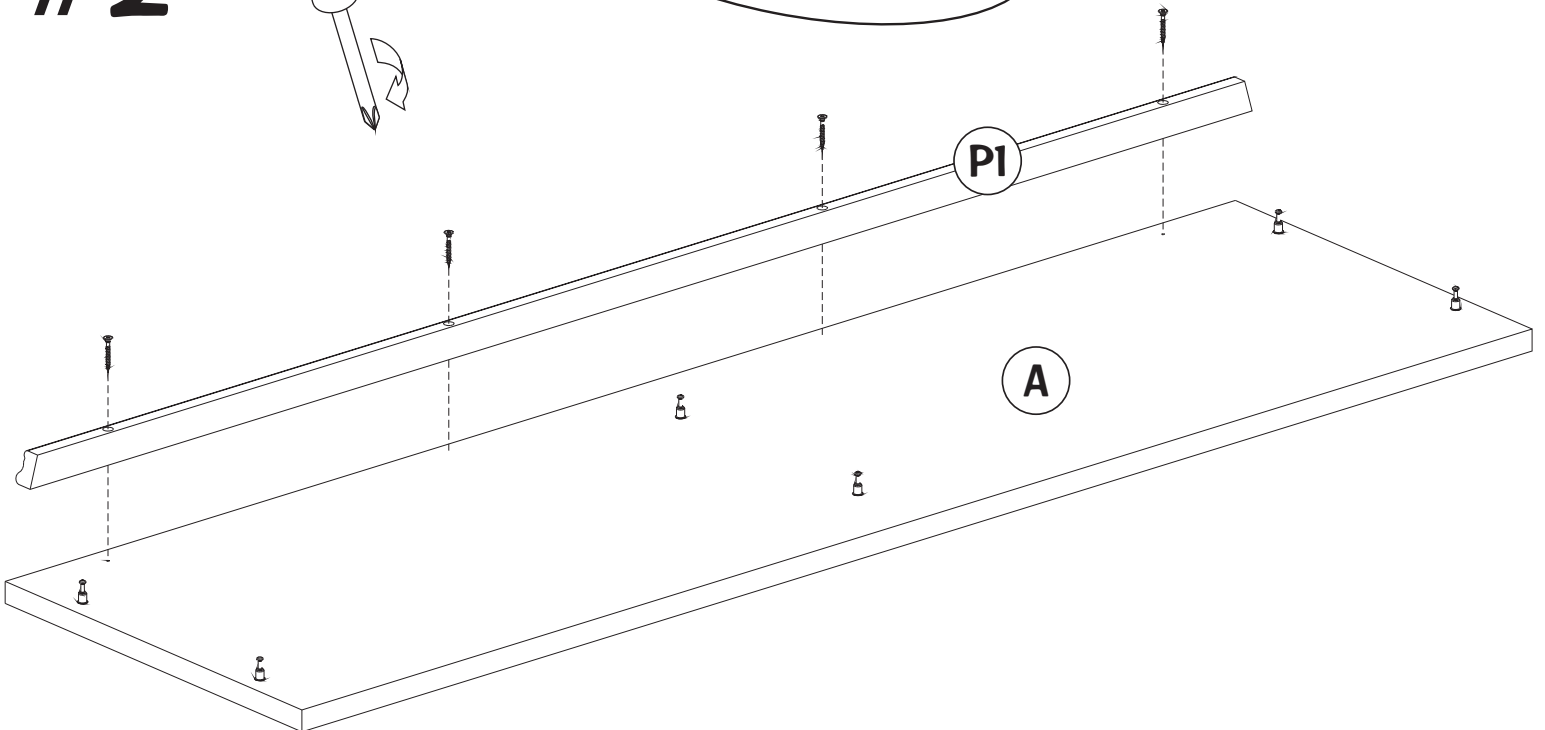

10

ASSEMBLY / ASSEMBLAGE / ARMADO

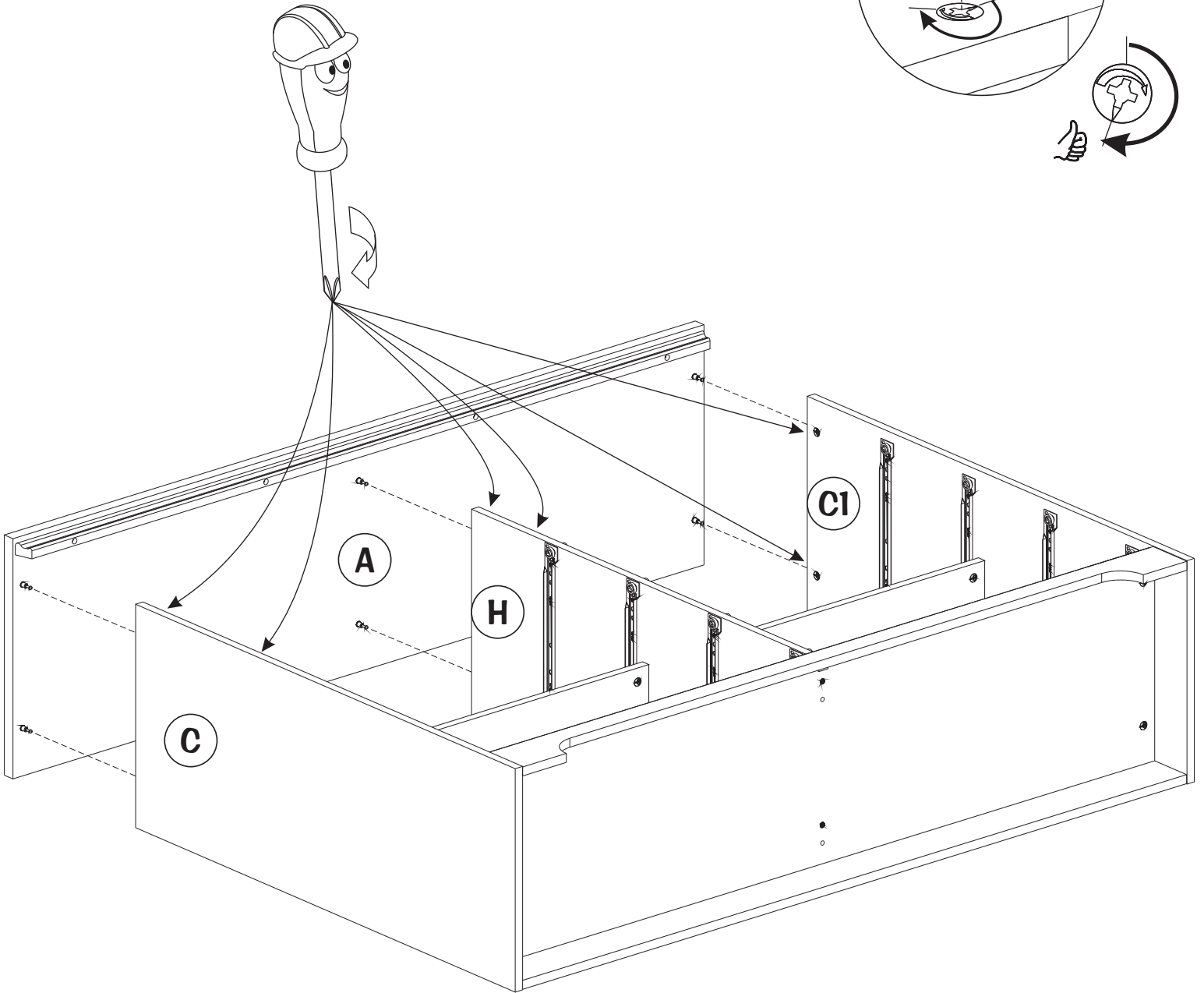
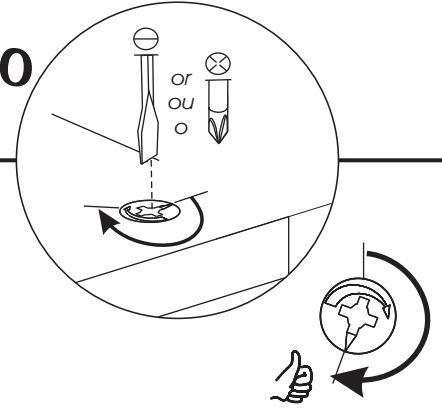



# 11

090 (x28)

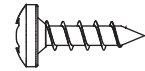

99 (x5)

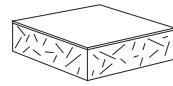

06 (x5)



Turn furniture  
Tourner le meuble  
Convertir los muebles

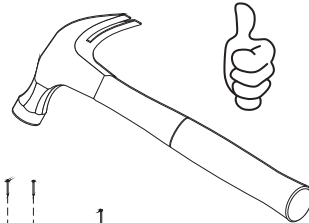
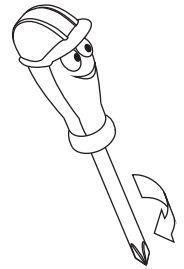
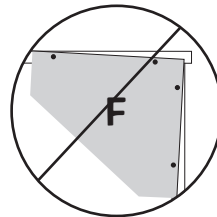
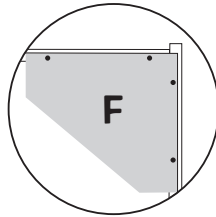

BACK  
ARRIÈRE  
DETRÁS

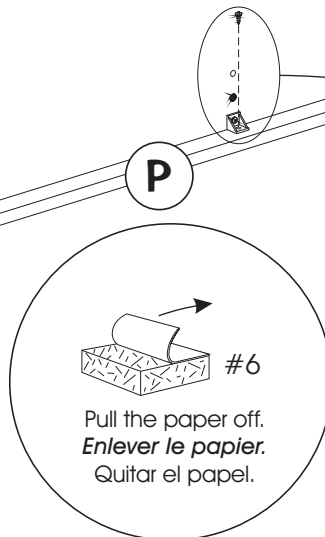
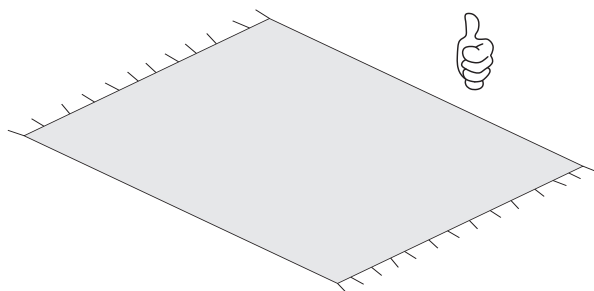
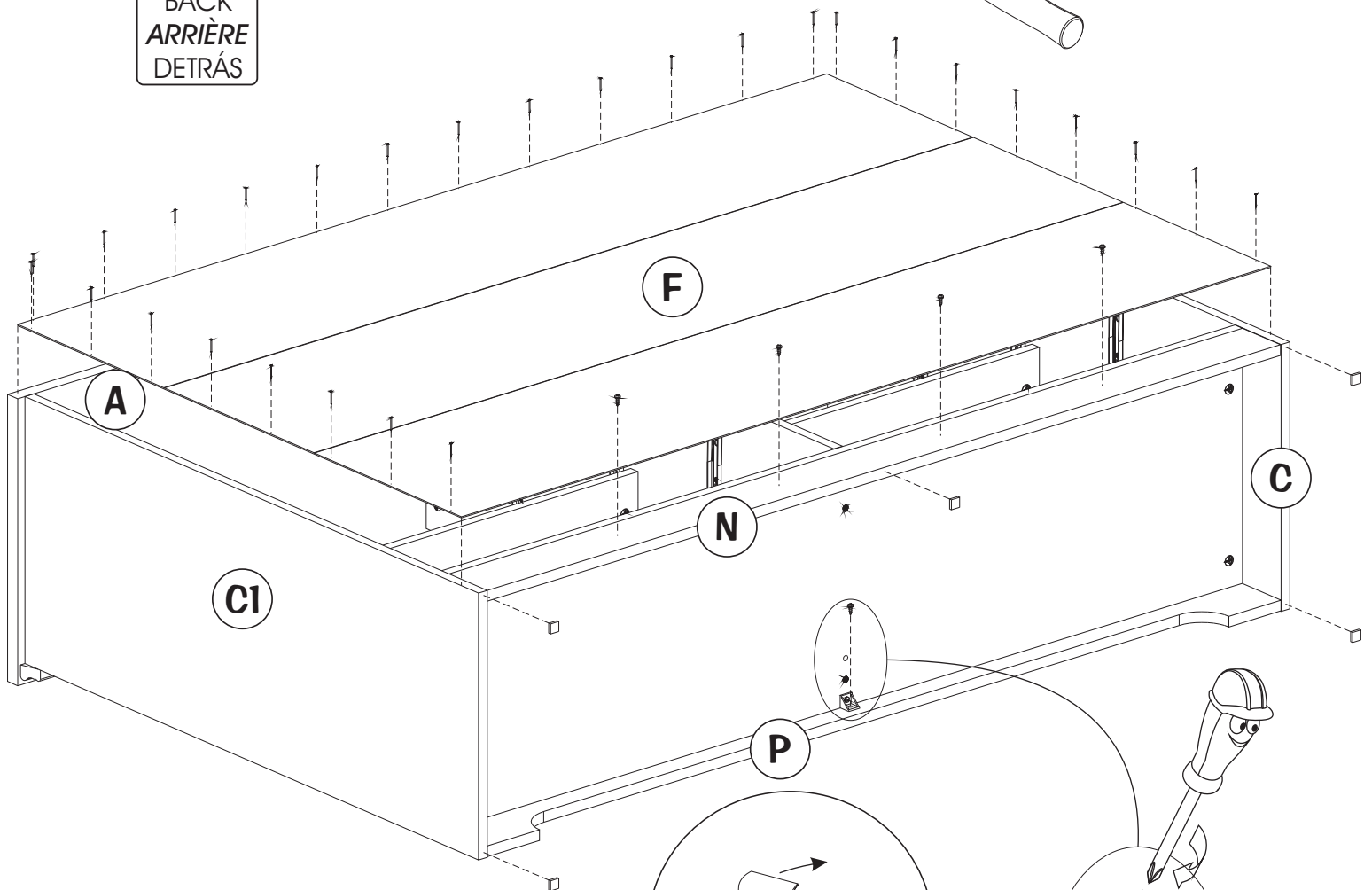

#6

Pull the paper off.  
Enlever le papier.  
Quitar el papel.

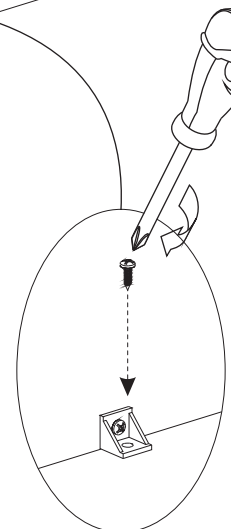

-Safety bracket installation  
 -Installation de l'équerre de sécurité  
 -Instalación del escuadra de seguridad

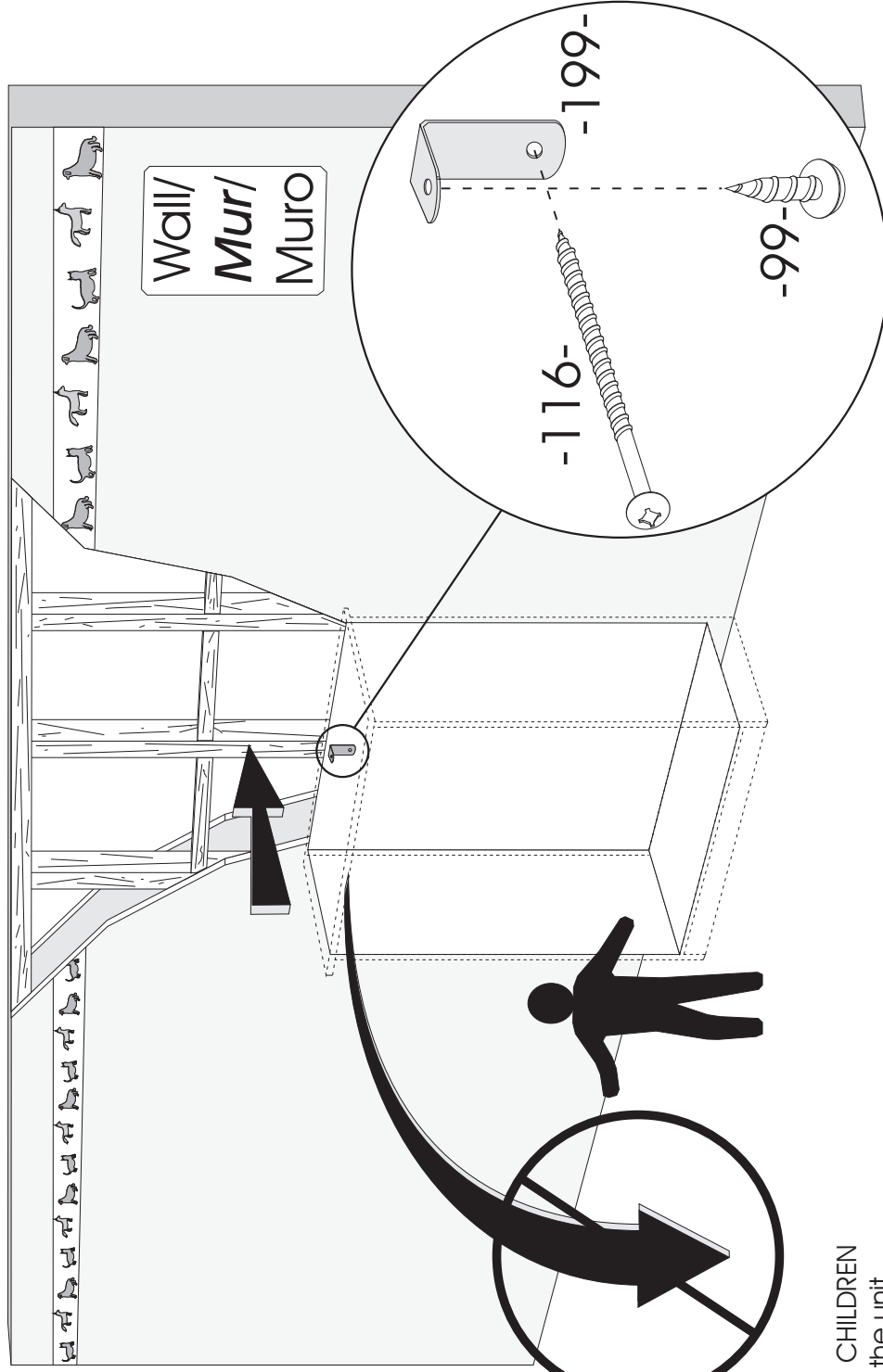

• TO PREVENT THE UNIT FALLING ON CHILDREN

- Locate a stud in the wall behind the unit.
- Screw -199- under the top with -99-. And through the back of the unit with -116- into the solid part of the wall.
- If the safety bracket is not in the box, please contact the consumer service in order to obtain another one before using the furniture.

• POUR EMPÊCHER LE MEUBLE DE BASCULER SUR LES ENFANTS

- Localiser un colombage, dans la largeur du meuble.
- Visser -199- sous le dessus du meuble avec -99-. Et à travers le dos du meuble avec -116-, dans la partie solide du mur.
- Si le crochet est absent, veuillez contacter notre service aux consommateurs pour obtenir cette pièce avant l'utilisation.

• POR IMPEDIR QUE EL MUEBLE VOLQUE SOBRE LOS NIÑOS.

- Localizar una viga, en la anchura del mueble.
- Atornillar -199- debajo la pieza del encima con -99-. Y a través del dorso del mueble con -116-, en la parte sólida del muro.
- Si falta el gancho de seguridad, deba ponerse en contacto con nuestro servicio al cliente para obtener un gancho antes de utilizar el mueble.

12

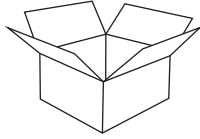

Box/Boîte/Caja #1

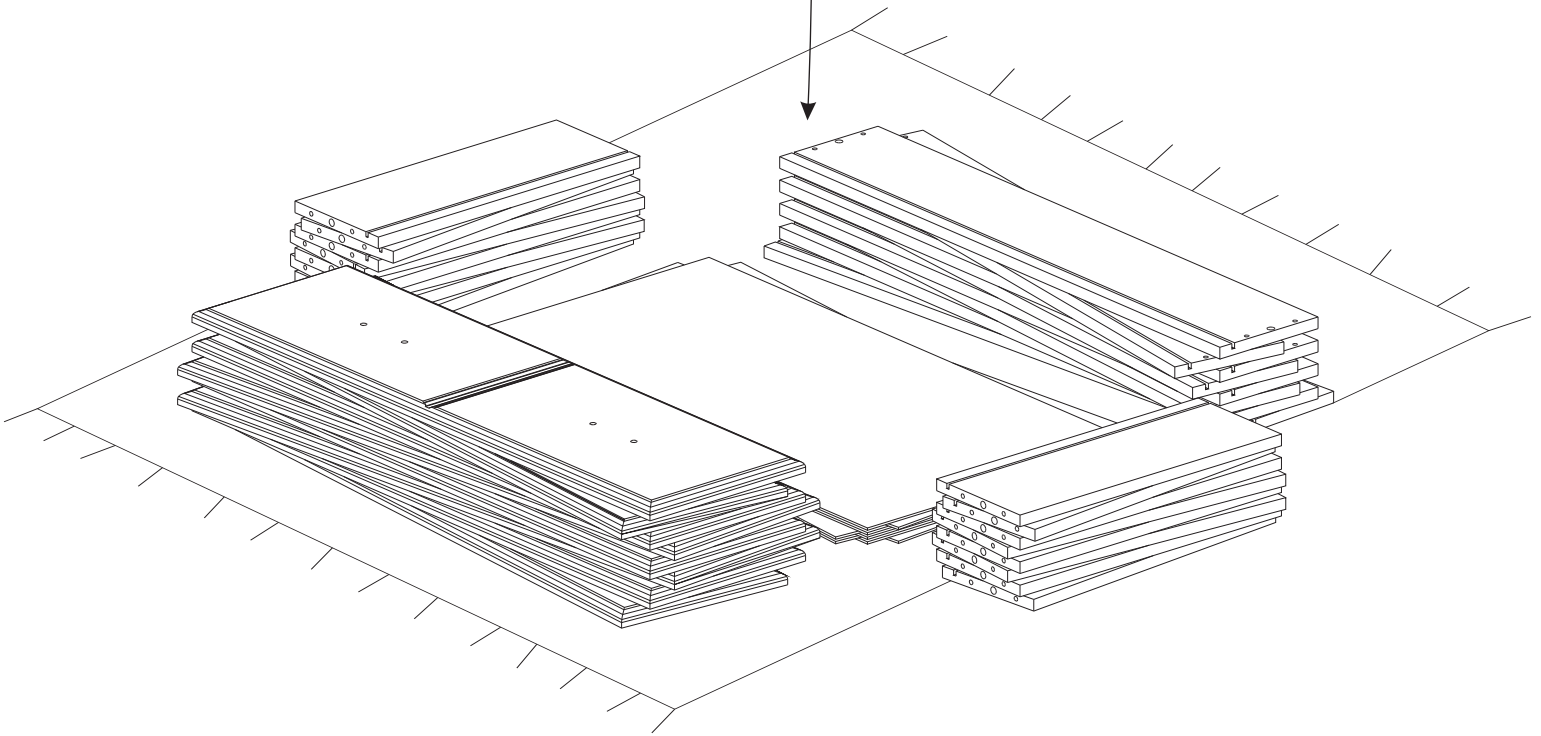
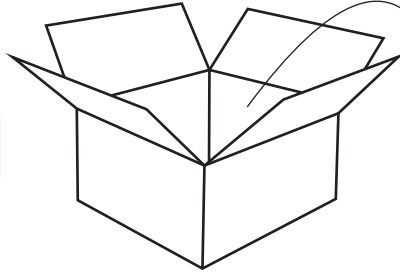

**R-R1-R2(3)-R3(3)-  
S(16)-T(8)-U(8)**

1

Drawers  
Tiroirs  
Cajones

# Drawers Tiroirs Cajones

-516-

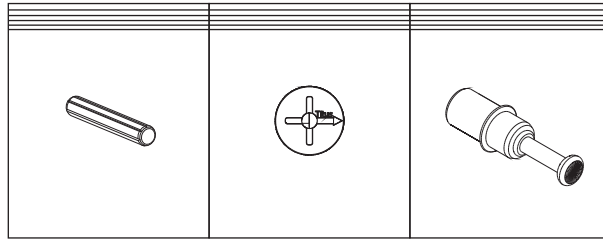

Each contain  
Chacun contient  
Cada uno contiene

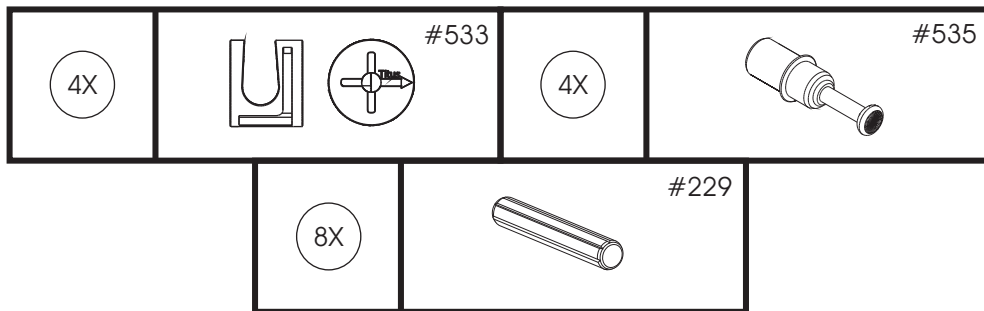

**2**  
Drawers  
Tiroirs  
Cajones

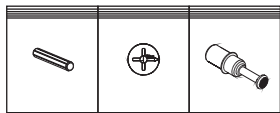

516 (x1)

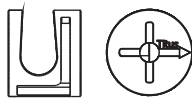

533 (x4)

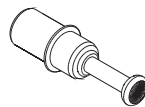

535 (x4)



229 (x8)

**8x** Drawers  
Tiroirs  
Cajones

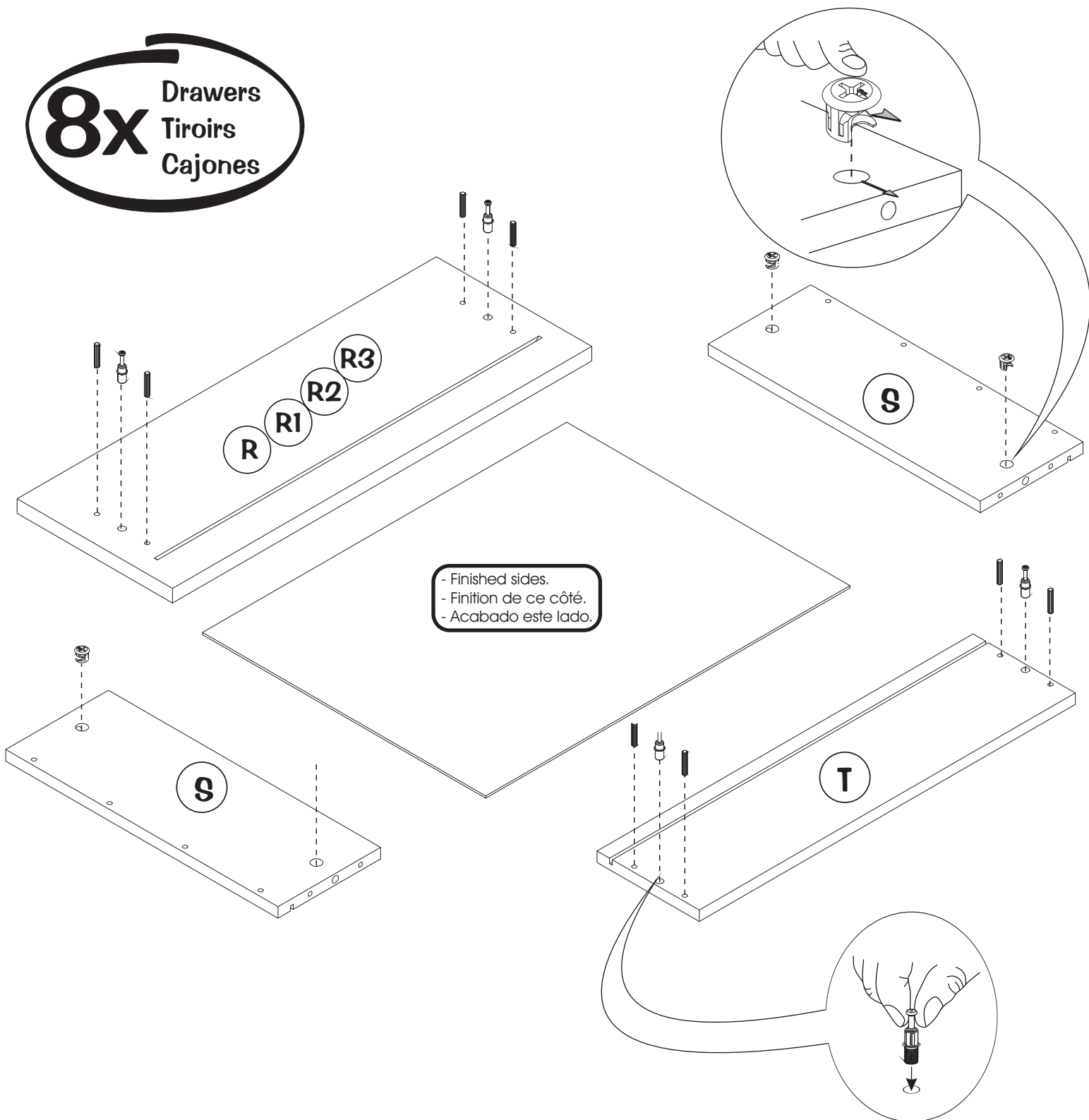

The image may differ depending on model  
L'image peut différer selon le modèle  
La imagen puede variar dependiendo del modelo

# 3

Drawers  
Tiroirs  
Cajones

## ASSEMBLY / ASSEMBLAGE / ARMADO

**8x** Drawers  
Tiroirs  
Cajones

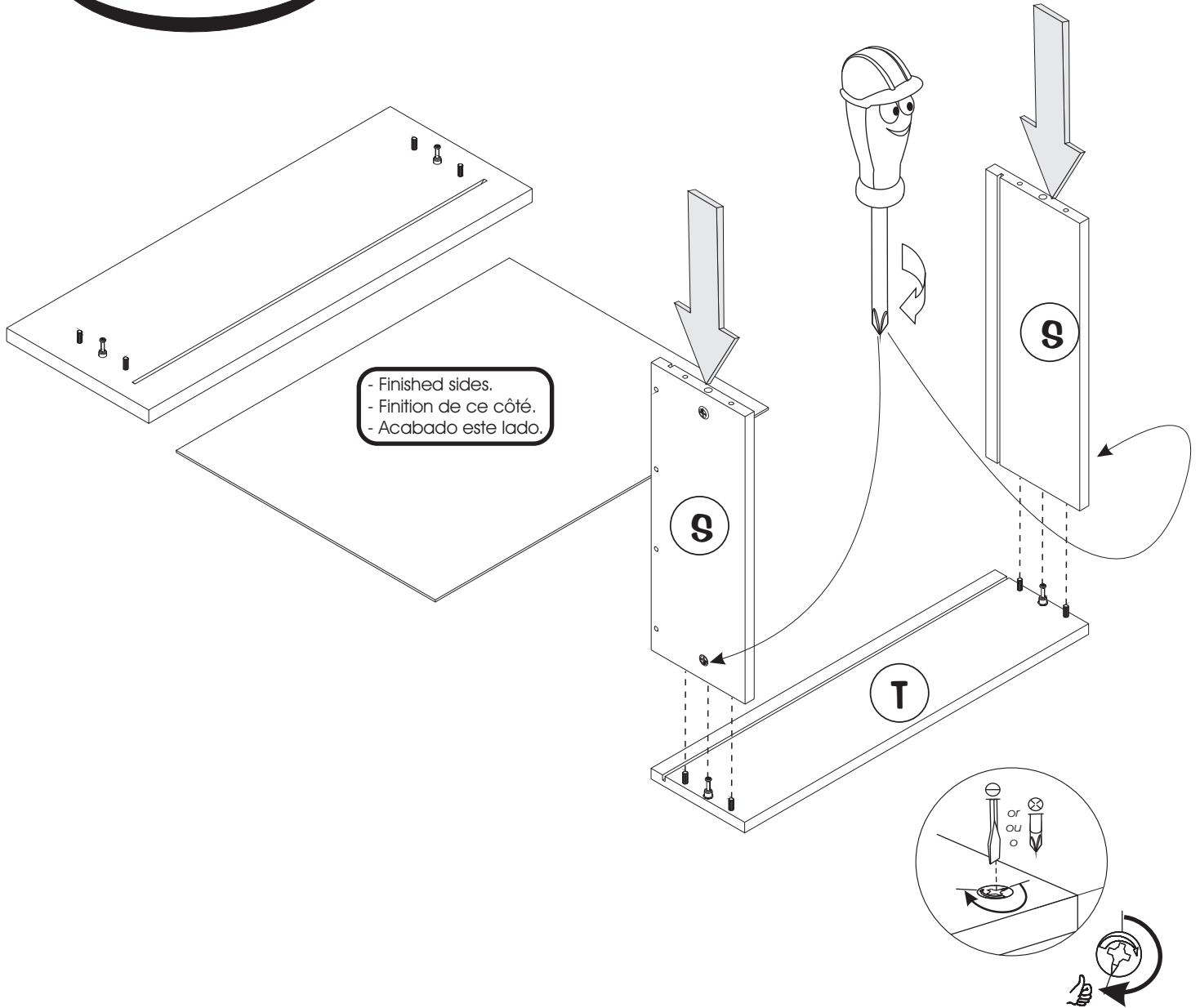

The image may differ depending on model  
L'image peut différer selon le modèle  
La imagen puede variar dependiendo del modelo

# 4

Drawers  
Tiroirs  
Cajones

## ASSEMBLY / ASSEMBLAGE / ARMADO

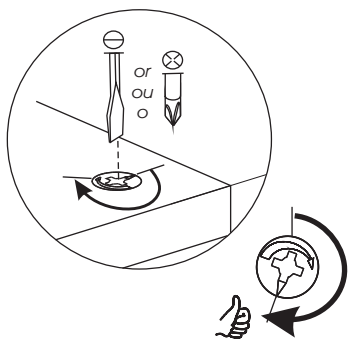
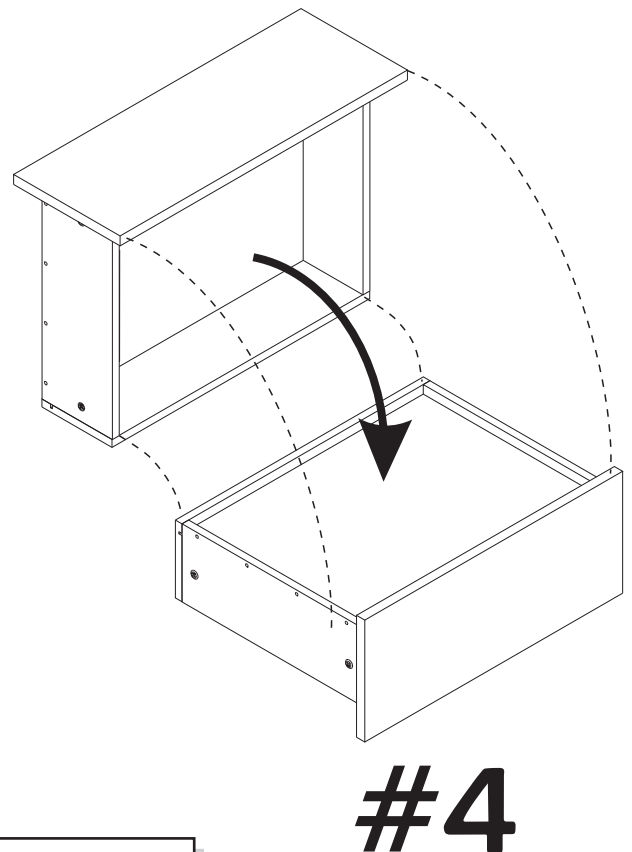
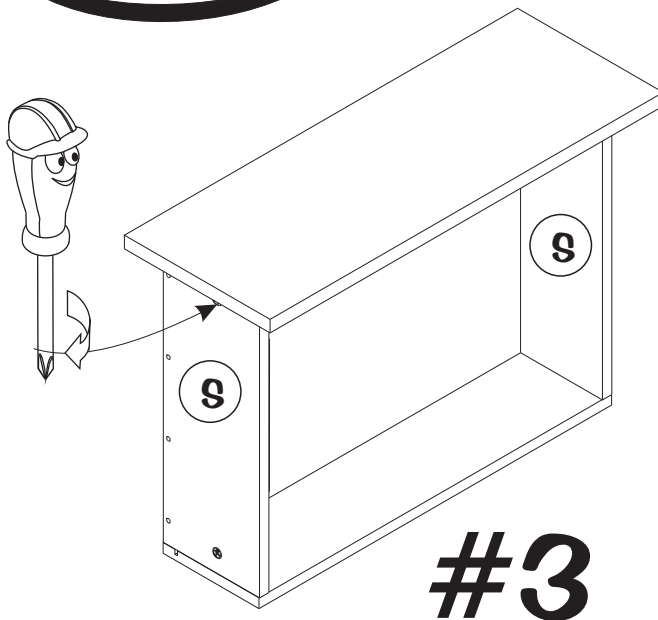
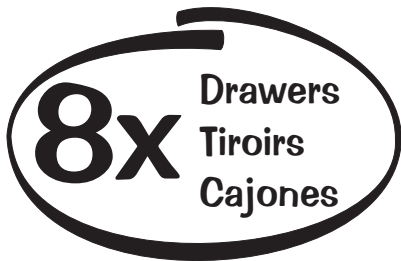
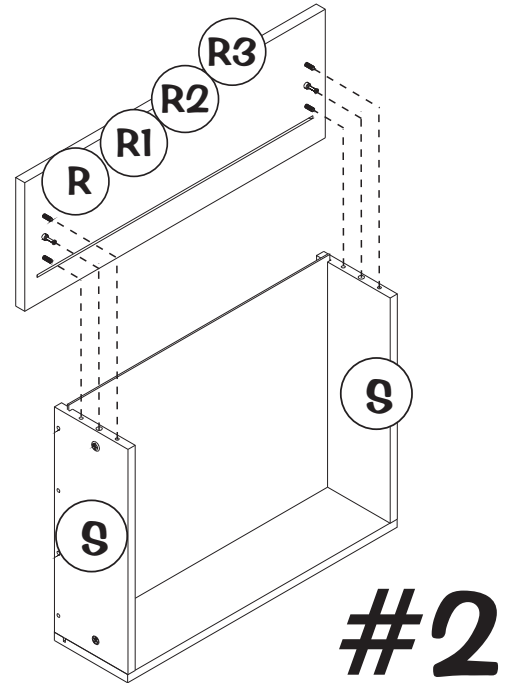
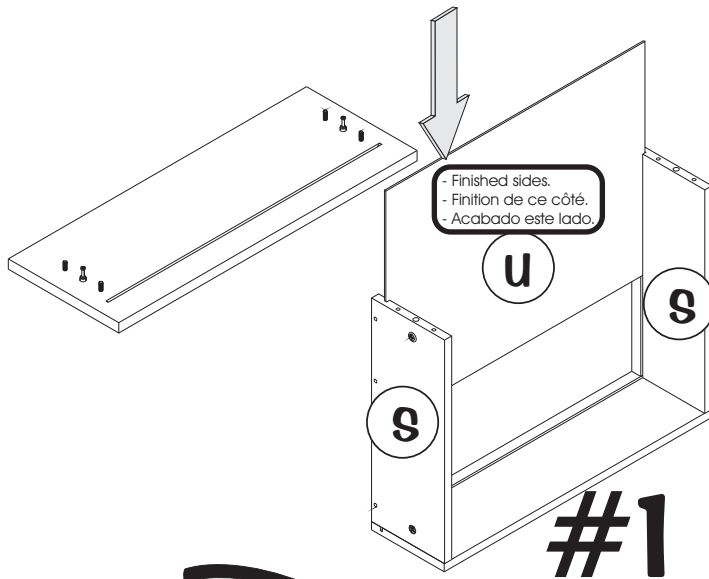

The image may differ depending on model  
L'image peut différer selon le modèle  
La imagen puede variar dependiendo del modelo

# 5

Drawers  
Tiroirs  
Cajones

**MANDATORY STEP** to ensure maximum strength of the drawer  
**ÉTAPE OBLIGATOIRE** afin d'assurer une solidité optimale  
**OBLIGATORIO** para asegurar una solidez óptima

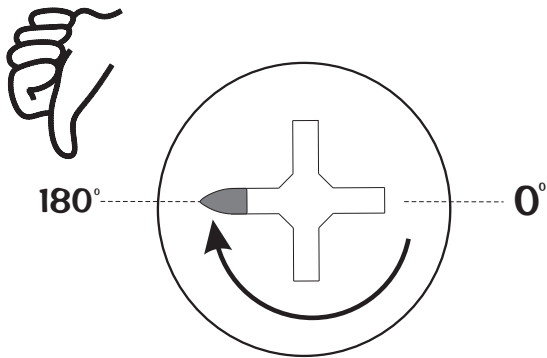
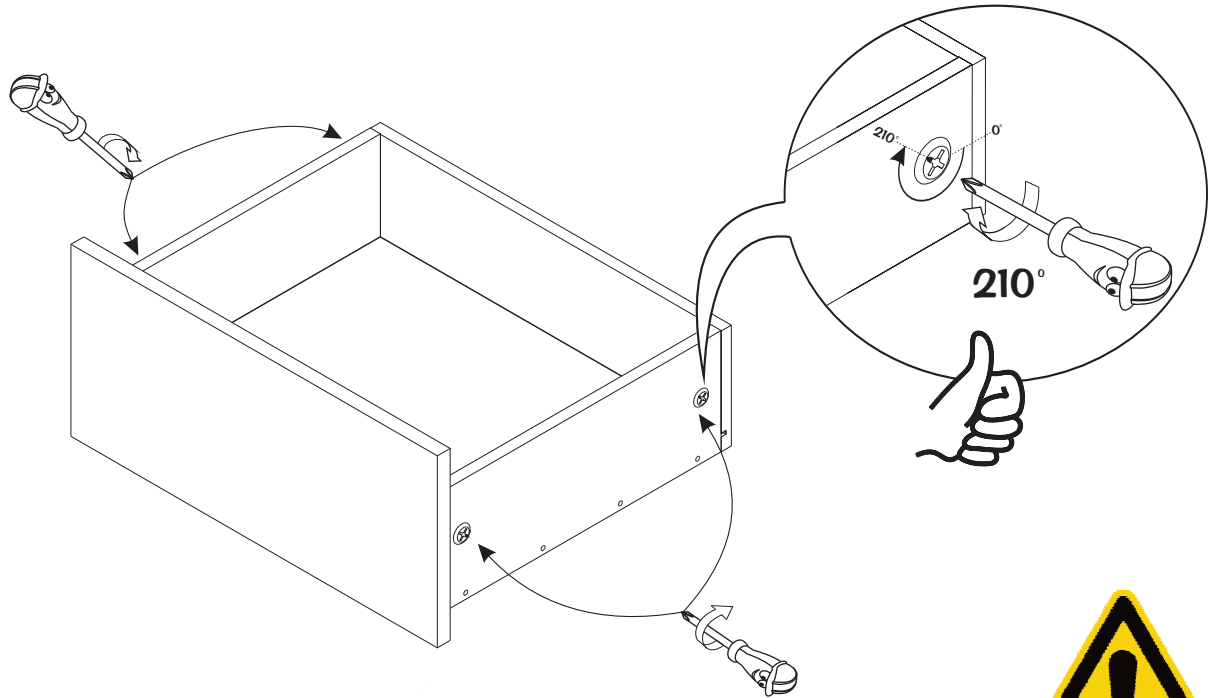

-Feel's like it's tight?

-Sensation d'avoir terminé le serrage?

-Sensación de haber terminado el atornillado?

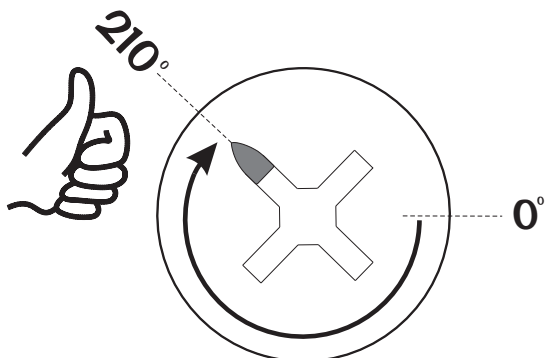

-Keep tightening, even if you feel it's locked.  
Don't worry, still 1/3 of a turn to get to optimal strength.

-Continuez à serrer même si résistance accrue. N'ayez pas peur, encore 1/3 de tour afin d'obtenir une solidité optimale.

-Continúe el atornillado aun si hay una resistencia. No tenga miedo, aun un 1/3 de vuelta para poder obtener una solidez óptima.



# 6

Drawers  
Tiroirs  
Cajones



92 (x4)

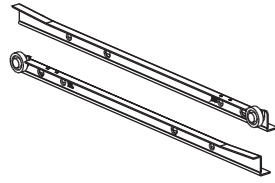

208 (x2)

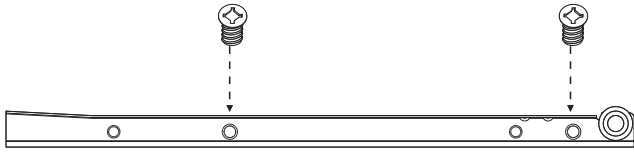

(DR)



(DL)

**8x** Drawers  
Tiroirs  
Cajones

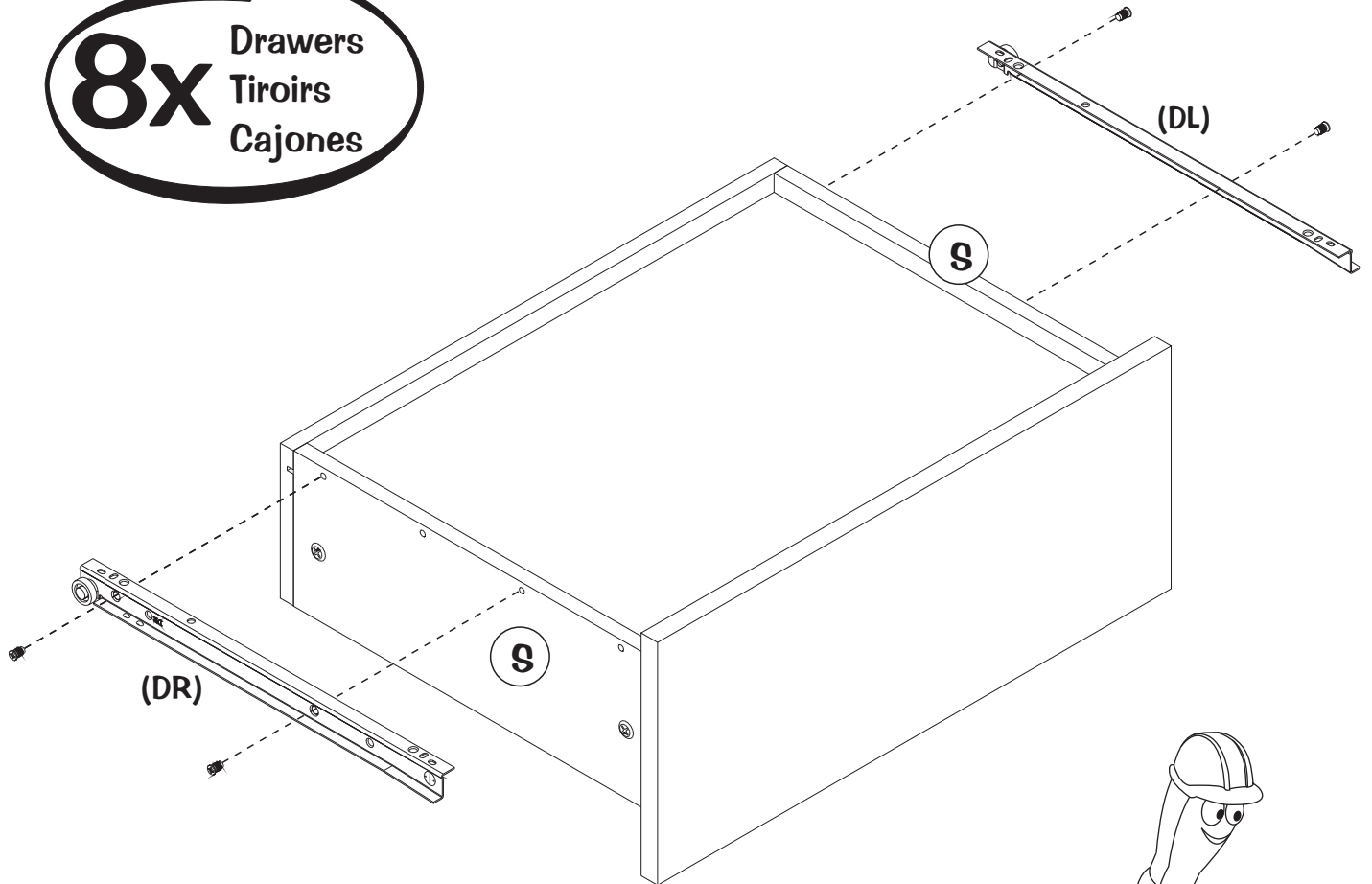

The image may differ depending on model  
L'image peut différer selon le modèle  
La imagen puede variar dependiendo del modelo

# 7

Drawers  
Tiroirs  
Cajones

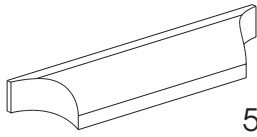

517 (x4)

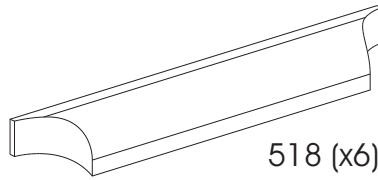

518 (x6)

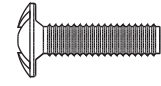

129 (x20)

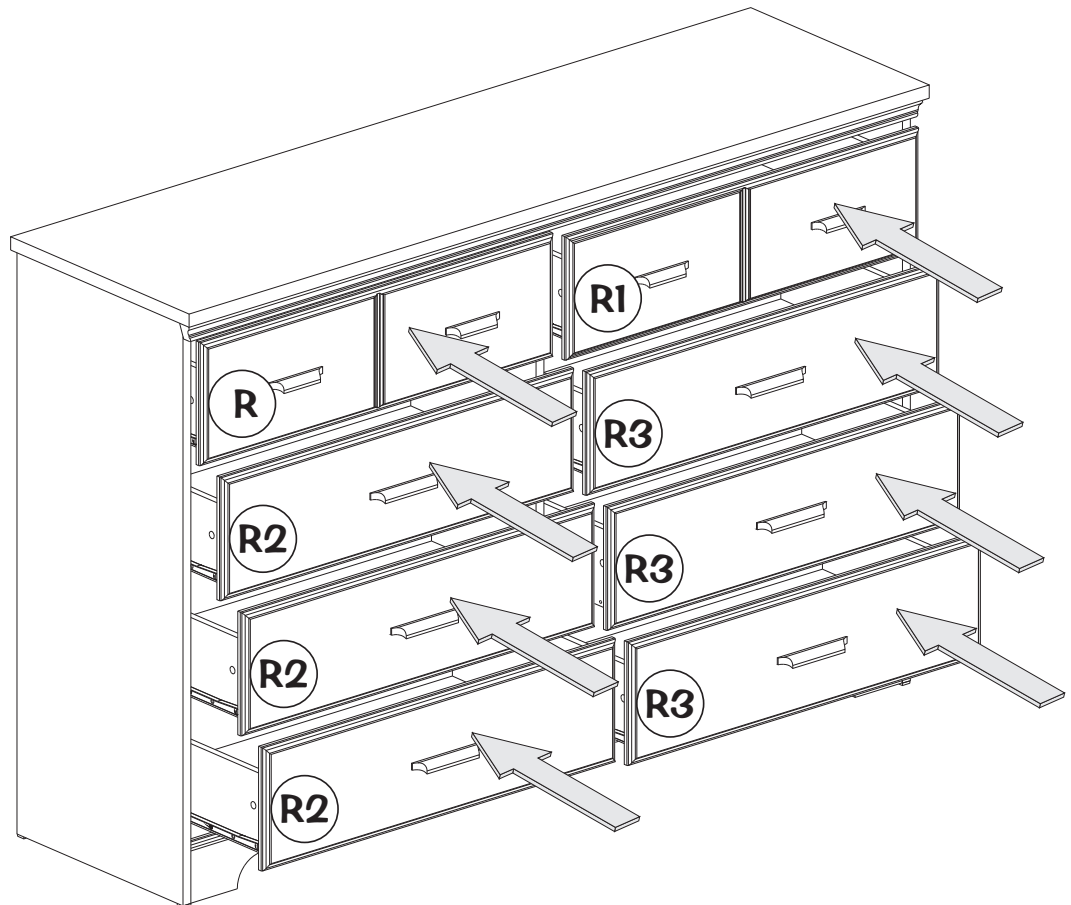
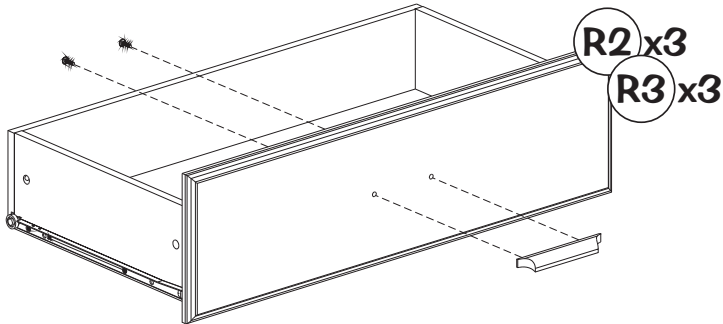
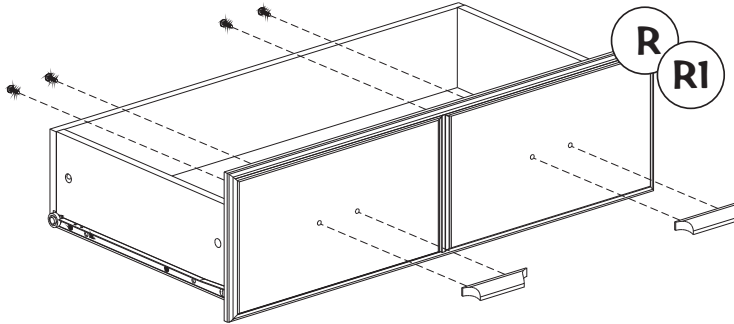

## MAINTENANCE TIPS / CONSEILS D'ENTRETIEN / CONSEJOS DE MANTENIMIENTO

- Never let liquids or damp cloths sit on this furniture.
- *Ne jamais laisser de liquide ou linge humide sur le meuble.*
- Nunca deje un líquido o un trapo húmedo sobre el mueble.



- Never use chemical cleaning products. They can damage the finish. For cleaning, use only a slightly damp cloth.
- *Ne jamais utiliser de nettoyeurs à base de produits chimiques, cela va endommager le fini. Utiliser seulement un linge légèrement humide.*
- Nunca utilice limpiadores a base de químicos, estos dañaran le acabado. Use sólo un paño húmedo.



- To avoid dulling of the finish, do not place furniture in direct sunlight.
- *Ne pas placer le meuble directement au soleil pour prévenir le ternissement.*
- No exponga el mueble directamente al sol para prevenir empañamiento.

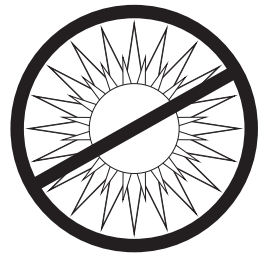

- Do not put plastic or rubber rings under appliances. Use cloth or felt protectors.
- *Évitez de déposer des appareils avec des rondelles de plastique ou de caoutchouc. Utilisez un protecteur en tissu ou en feutre.*
- Evite apoyar aparatos con redondeles de plástico o de goma. Utilizar un protector de tela o de fieltro.



- To clean, use a soft or slightly damp cloth, then wipe with a clean, dry cloth.
- *Pour nettoyer, utilisez un linge doux ou légèrement humecté. Essuyez par la suite avec un linge propre et sec.*
- Para limpiar, utilice un trapo suave o ligeramente humedecido. Seque luego con un trapo limpio y seco.



## 5 YEARS LIMITED WARRANTY

## GARANTIE LIMITÉE DE 5 ANS

## GARANTIA LIMITADA DE 5 AÑOS

1. South Shore™ Furniture provides the original buyer with a warranty covering "defects" on furniture parts and workmanship for a period of 5 years from the date of purchase.

2. The word "defect" as used in this warranty is defined as any imperfection that may impair the intended use of the product.

3. This warranty is strictly limited to the repair or replacement of defective component parts, and excludes all other direct or indirect charges and expenses up to the limit permitted by law in your state/province.

4. In the case of a discontinued part or product, South Shore™ Furniture promises to reimburse the value of that part or product.

5. If a replacement part is unavailable, South Shore™ Furniture's liability to the buyer will not exceed the production cost of the part in question.

6. This warranty only applies under conditions of normal domestic use. It does not cover defects resulting from commercial use, intentional damage, negligence, abuse, product modification, accidents, exposure to the elements, or maintenance that does not comply with the guidelines in this guide.

7. To honor this warranty, South Shore™ Furniture reserves the right to verify the grounds of any request and to ask for the original buyer's proof of purchase.

8. This warranty is only valid on purchases made at authorized South Shore™ Furniture retailers in Canada, the U.S., Mexico.

9. This warranty defines the limits of South Shore™ Furniture's liability, and entitles the original buyer to specific rights. Any warranty defined by law in your state/province is limited to a period of 5 years. If the law in your state/province prohibits this restriction, then it does not apply.

10. South Shore™ Furniture will not reimburse defective furniture, but will replace it with an item of equivalent value.

-----  
To qualify for your warranty, please take a moment to fill out our online registration form ([southshorefurniture.com/southshore.ca](http://southshorefurniture.com/southshore.ca))

*Afin de bénéficier de votre garantie, nous vous invitons à remplir le formulaire d'enregistrement en ligne ([southshore.ca](http://southshore.ca))*

Para obtener su garantía, tenga a bien llenar nuestro formulario en línea ([southshorefurniture.com](http://southshorefurniture.com))

1. Meubles South ShoreMC garantit à l'acheteur original, pour une période de 5 ans à partir de la date d'achat, toutes les composantes des meubles contre les « défauts » de matériaux et de main- d'œuvre.

2. Le mot « défaut » utilisé dans cette garantie signifie une imperfection pouvant altérer l'utilité pour laquelle le produit est destiné.

3. Cette garantie se limite strictement à la réparation ou au remplacement des pièces et composantes défectueuses. Cette garantie exclut tous les autres frais et dépenses directs ou indirects et ce, jusqu'à la limite permise par la législation en vigueur dans votre province/état.

4. Dans le cas d'une réclamation concernant un produit ou une pièce discontinuée, Meubles South ShoreMC s'engage à rembourser la valeur du produit ou de la pièce en question.

5. À défaut de pouvoir fournir la pièce de remplacement, la responsabilité de Meubles South ShoreMC ne peut excéder la valeur équivalente au coût de production de la pièce en litige.

6. Cette garantie s'applique sous des conditions d'usage domestique normal et ne couvre pas les défauts pouvant résulter d'un usage commercial, de dommages intentionnels, de la négligence, de l'usage abusif, de modifications personnelles, d'un accident, de l'exposition aux éléments ou d'un entretien ne respectant pas les conseils décrits dans ce guide.

7. Comme condition pour fournir une pièce de remplacement, Meubles South ShoreMC se réserve le droit de vérifier le fondement de la requête, de même que d'exiger la preuve d'achat de l'acheteur original.

8. Cette garantie n'est valide que si et seulement si l'achat a été effectué chez un marchand autorisé par Meubles South ShoreMC au Canada, aux États-Unis, au Mexique.

9. Cette garantie définit les limites de la responsabilité de Meubles South ShoreMC et donne à l'acheteur original des droits spécifiques. Toute garantie législative prévalant dans votre lieu de résidence est limitée à une période de 5 ans. Si cette restriction n'est pas permise par la législation de votre province/état, elle ne s'applique pas.

10. Meubles South ShoreMC ne remboursera pas un meuble défectueux, mais le remplacera par un autre de valeur équivalente.

1. South ShoreMR garantizan al comprador original, por un período de 5 años a partir de la fecha de compra, todas las piezas que componen el mueble contra los « defectos » de material y mano de obra.

2. La palabra « defecto » utilizada en esta garantía se define como toda imperfección que pueda alterar la utilidad para la cual se destina el producto.

3. Esta garantía se limita estrictamente a la reparación o reemplazo de las piezas que tengan componentes defectuosos. Esta garantía no incluye cualquier gasto directo o indirecto hasta el límite permitido por la legislación vigente en su lugar de residencia.

4. En el caso de una reclamación referente a un producto o pieza discontinuada, South ShoreMR se compromete a reembolsar el valor del producto o pieza en cuestión.

5. A falta de poder suministrar la pieza de repuesto, la responsabilidad de South ShoreMR no puede exceder el valor equivalente al costo de producción de la pieza en litigio.

6. Esta garantía se aplica bajo las condiciones de uso doméstico normal y no cubre los defectos que puedan resultar de un uso comercial, daños intencionales, negligencia, uso abusivo, modificaciones personales, un accidente, exposición a los elementos y mantenimiento sin respetar los consejos que se describen en este instructivo.

7. Como condición para suministrar una pieza de repuesto, South ShoreMR se reservan el derecho de verificar el fundamento de la solicitud, así como de exigir la prueba de compra del comprador original.

8. Esta garantía sólo será válida si la compra se efectuó en una tienda autorizada por Muebles South ShoreMR de Canadá, estados Unidos, México.

9. Esta garantía define los límites de la responsabilidad de South ShoreMR y otorga el comprador original los derechos específicos. Cualquier garantía legislativa que prevalece en su lugar de residencia está limitada a un período de 5 años. Si esta restricción no está permitida por la legislación de su lugar de residencia, ésta no se aplica.

10. South ShoreMR no hará ningún reembolso por muebles defectuosos, pero le enviará uno de valor equivalente.

CUSTOMER SERVICE / SERVICE À LA CLIENTÈLE / SERVICIO AL CLIENTE

**CANADA / USA**

 **1-800-290-0465** 

**MEXICO (buzón)**

 **001-800-514-5320**  toll free number / lada sin costo



**South Shore**

6168, Rue Principale  
SAINTE-CROIX, QUÉBEC  
CANADA, G0S 2H0



E-MAIL: [service@southshore.ca](mailto:service@southshore.ca)  
WEB: [www.southshore.ca](http://www.southshore.ca)  
[www.southshorefurniture.com](http://www.southshorefurniture.com)

