

DO NOT RETURN PRODUCT TO THE STORE
Individual stores do not stock parts.

NO REGRESE EL PRODUCTO A LA TIENDA
Las tiendas individuals no proveen de partes de recambio

Lot Number / Número de Lote: _____

Date Of Purchase / Fecha de Compra: ___/___/___

If a part is missing or damaged, call our toll-free customer service line. We will gladly ship your replacement parts FREE of charge.

Si falta partes o las partes están dañadas, llame gratis al servicio del cliente. Nosotros con gusto se las mandaremos las partes que necesite sin recargo alguno.

Need Parts or Assistance?
Nesacitas partes o asistencia?

1-800-489-3351

or access our website
o visite nuestra página de internet

www.altrafurniture.com

For prompt, reliable service please have your assembly manual ready.
Para un servicio más rápido y confiable, por favor tenga esta manual a la mano.

THIS INSTRUCTION BOOKLET CONTAINS **IMPORTANT** SAFETY INFORMATION. PLEASE READ AND KEEP FOR FUTURE REFERENCE.

ESTE FOLLETO DE INSTRUCCION CONTIENE INFORMACION **IMPORTANTE** DE SEGURIDAD. POR FAVOR LEA Y GUARDE PARA REFERENCIA FUTURA.

Recommended # of people needed for assembly: 2

Número recomendado de personas necesarias para el montaje: 2

B34982009600

Thank you for purchasing from Altra Furniture.
Visit www.altrafurniture.com to view the limited warranty valid in the U.S. and Canada.

ALTRA FURNITURE CUSTOMER SERVICE

Gracias por haber comprado de Altra Furniture.
Visite www.altrafurniture.com para mirar la garantía limitada, la cual es válida solamente en U.S.A y Canada.

SERVICIO A LA CLIENTE DE ALTRA FURNITURE

Before starting - Antes de empezar.

- Read each step carefully before starting. It is very important that each step of instruction is performed in the correct order. If these steps are not followed in sequence, assembly difficulties will occur.
Leer con cuidado cada paso antes de empezar. Es muy importante de ejecutar cada paso en el orden correcto. Si los pasos no están ejecutados en secuencia, ocurrirá dificultades en el montaje.
- Make sure all parts are included. Most board parts are labeled or stamped on the raw edge.
Asegurese de que todos las piezas están incluidas. La mayoría de los tableros tienen las etiquetas o los sellos en las esquinas sin acabado.
- Work in spacious area, preferably on a carpet, near the place the unit will be used.
Haga el montaje en una área espaciosa, preferiblemente sobre una alfombra, cerca del lugar donde se va a usar el mueble.
- Have the following tools close at hand.
Tenga las siguientes herramientas a mano.
- Do not use power tools to assemble your furniture. Power tools may strip or damage the parts.
No use herramienta eléctrica para montar esta unidad. Las herramientas eléctricas pueden dañar las piezas de ensamble.

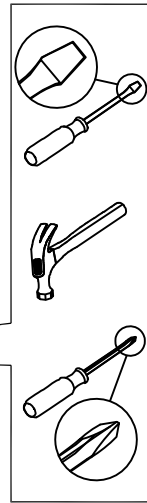

Call us at: **1-800-489-3351**
(in U.S.A. only)
Llamar a: (Solo en U.S.A)

Monday - Friday 7:00 am - 8:00 pm Central Time	Saturday 9:00 am - 5:00 pm Central Time
--	---



Fax: **1-636-745-1005**
Fax:

Lunes - Viernes 7:00h - 20:00h Tiempo Central	Sabado 9:00h - 17:00h Tiempo Central
---	--

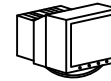

Visit our Website:
Visite nuestro website: www.altrafurniture.com



Write to: **ALTRA FURNITURE**
Escribir a: 410 East 1st Street South Wright City, MO 63390 USA
Attn: Service Dept.

HELPFUL HINTS

- Visit our website for assembly video clips.
- Identify, sort and count the parts before attempting assembly.
- Call our toll free number if you need assistance identifying parts.
- Compression dowels are tapped in with a hammer.
- Slides have lips only on the right side.
- Cam locks that are properly fastened on a horizontal board will face toward the center of the unit, on a vertical board the point on the lock will face the bottom.
- Back panels provide stability and support. Use all the nails provided.
- When tapping nails into a board, be sure there are equal margins on all sides to square the unit.
- Units without the back panel installed may collapse.
- Clean the product with your favorite furniture polish and a soft cloth. **DO NOT USE** harsh chemicals or abrasive cleaners.
- Move your new furniture carefully, with two people lift and carry the unit to its new location.
- Never push, drag or scoot your furniture (especially on carpet).
- Your ALTRAFURNITURE can be disassembled and reassembled to move.
- Additional parts are available for a nominal fee.

CONSEJOS ÚTILES

- Visite nuestro website para mirar los videos de montaje.
- Identificar, clasificar y contar las piezas antes de intentar el montaje.
- Llame gratis a nuestro número de servicio si necesita ayuda.
- Las clavijas de compresión se taladran con un martillo.
- Las correderas sólo tienen las protrusiones en el lado derecho.
- Las cerraduras de leva que se atan propiamente en una tabla horizontal se puntan al centro de la unidad, y las en una tabla vertical se puntan al fondo.
- Los paneles traseros son los que mantienen la estabilidad. Use todas las uñas proporcionadas.
- Cuando taladre la uñas en la tabla, asegurarse que hay márgenes iguales en todos los lados para centrar la unidad.
- Las unidades sin panel trasero pueden derrumbarse.
- Limpiar la unidad con su pulimento favorito de mueble y una tela suave. **NO UTILIZAR** productos con químicos duros o abrasivos.
- Mueva su mueble nuevo cuidadosamente, lo ideal son dos personas para levantar la unidad a su nuevo lugar.
- Nunca empuje o arrastre su mueble (especialmente sobre alfombras).
- Su mueble ALTRAFURNITURE puede desmontarse y volverse a montar para moverlo de sitio.
- Las piezas adicionales están disponibles bajo pedido con costo adicional.

PARTS -PIECES

A

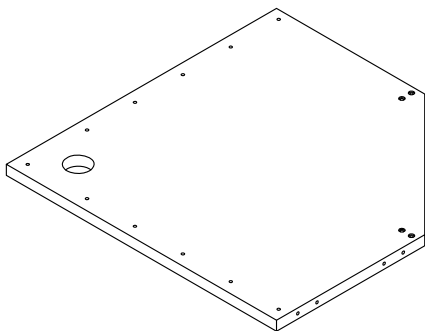

MIDDLE TOP
Panel superior central
T9820096010

B

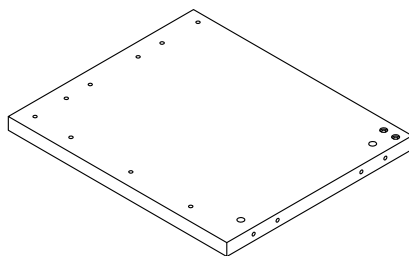

LEFT TOP
Panel superior izquierdo
T9820096020

C

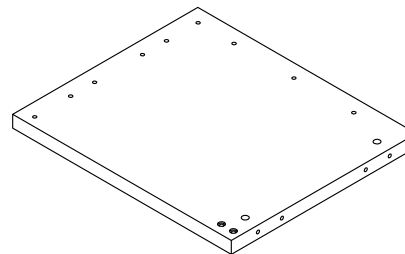

RIGHT TOP
Panel superior derecho
T9820096030

D

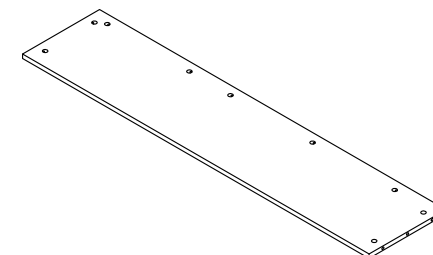

LEFT BACK PANEL
Panel trasero izquierdo
T9820096040

E

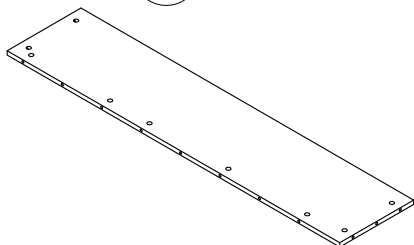

RIGHT BACK PANEL
Panel trasero derecho
T9820096050

F

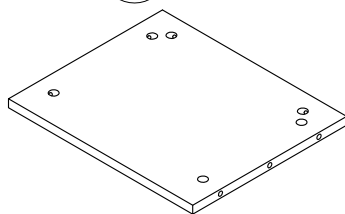

SIDE PANEL
Panel lateral
T9820096060
QTY:2

G

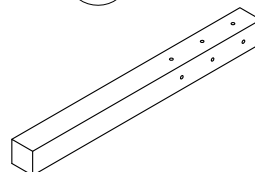

BACK RAIL
Riel trasero
T9820096070
QTY:3

H

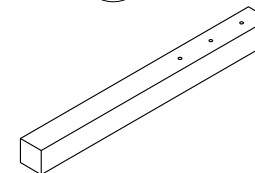

RIGHT RAIL
Carril derecho
T9820096080

I

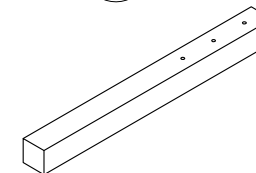

LEFT RAIL
Carril izquierdo
T9820096090

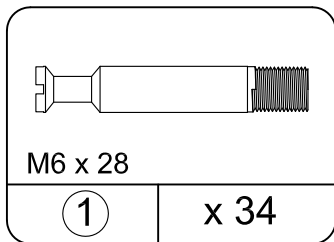

CAM BOLT
Leva de Perno
TDK0001

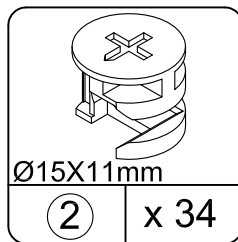

CAM LOCK
Leva de Cerradura
TDK0002

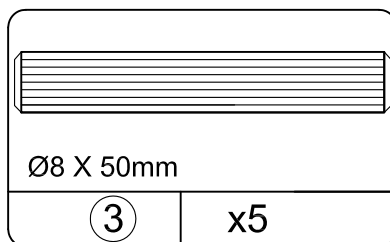

WOOD DOWEL
Clavija de madera
TDK0202

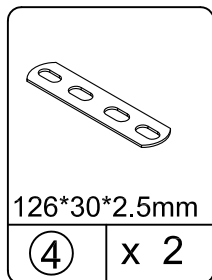

METAL PLATE
Placa de metal
TDK2006

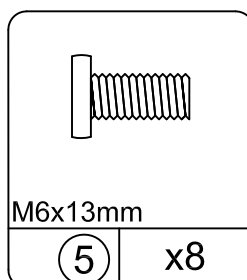

BOLT
perno
TDK0116

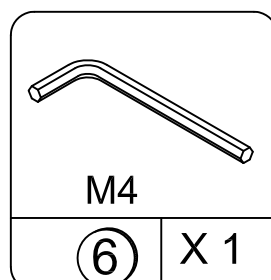

HEX KEY
Llave en L
TDK0006

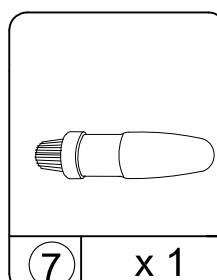

GLUE
La cola
TDK2000

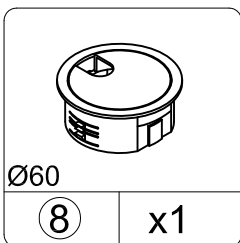

WIRE GROMMET
Ojal de alambre
TDK1121

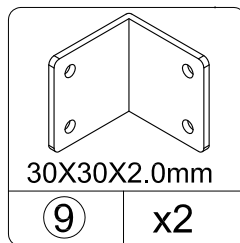

ANGLE BRACKET
Escuadra
TDK2007

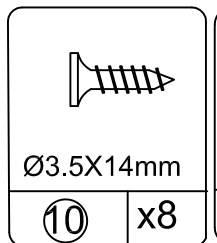

SCREW
Tornillo
TDK0008

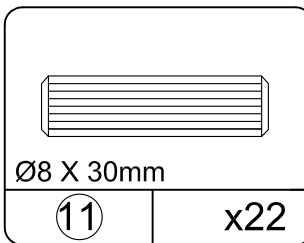

WOOD DOWEL
Clavija de madera
TDK0201

This illustration shows how the CAM fastening system works.

Esta ilustración muestra como funciona el sistema de fijación de leva.

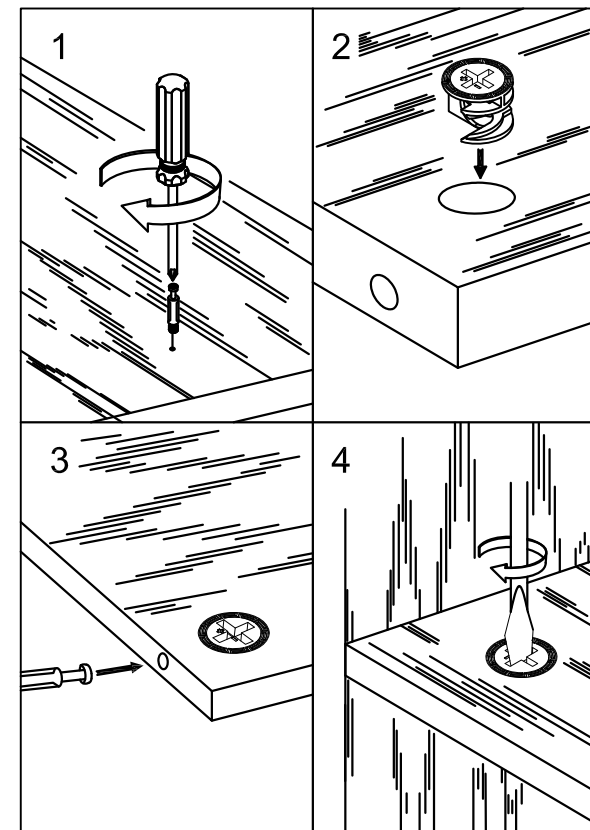

To view a video on how the CAM fastening system works, download a free QR-reader on your smartphone, then scan the code.

Para ver un video de como funciona el sistema de sujeción CAM, descargue una aplicación gratis que podra ver en su teléfono movil, entonces escnee el código.

1

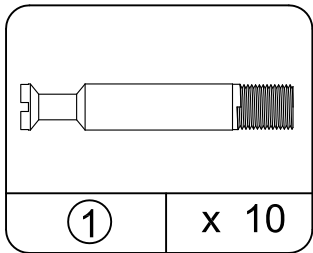
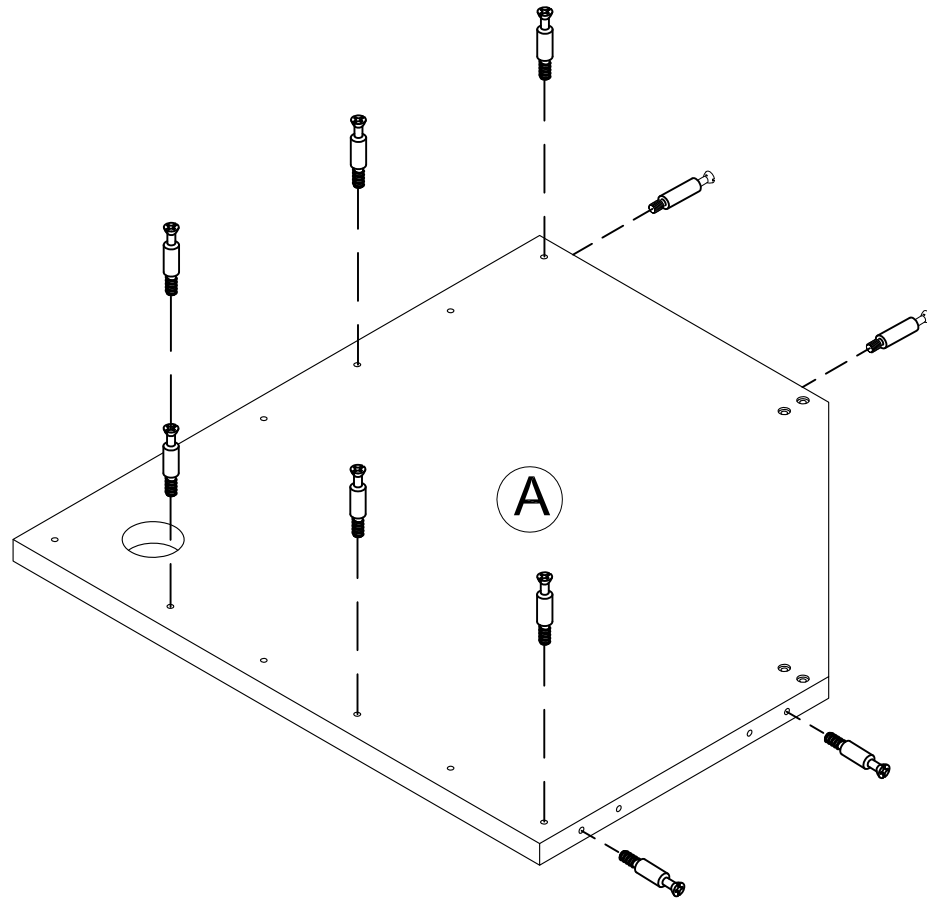

2

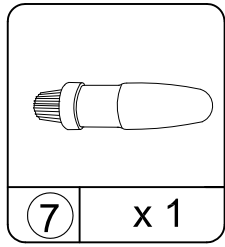
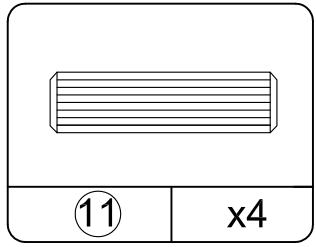
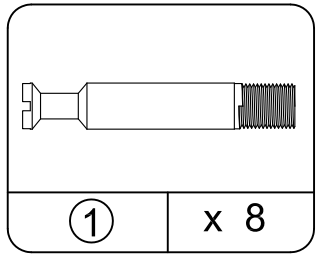
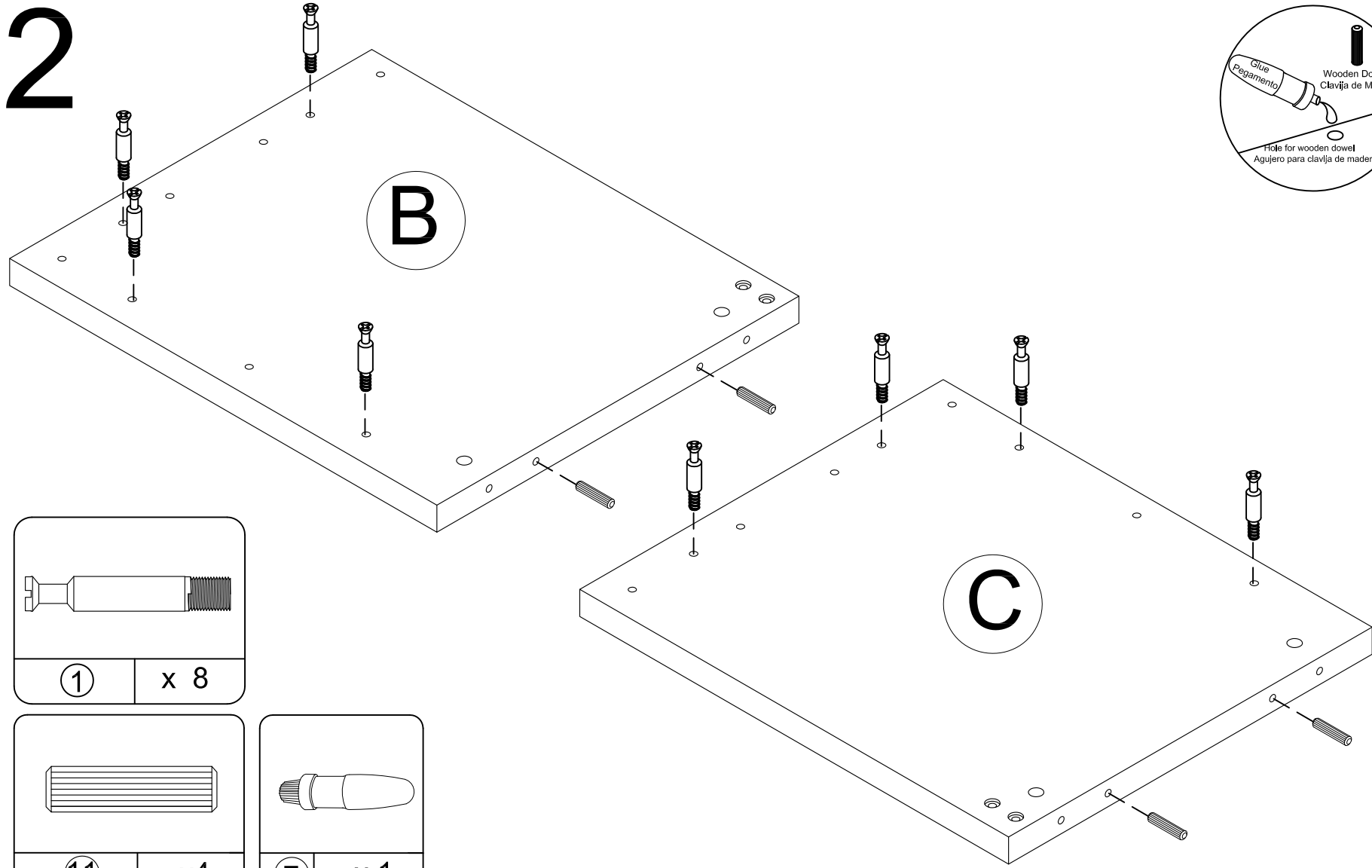

3

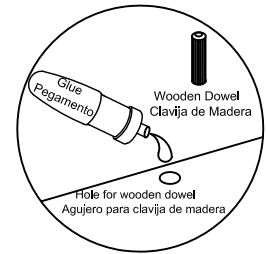
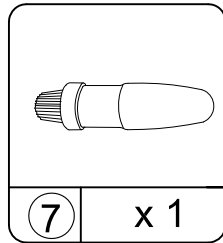
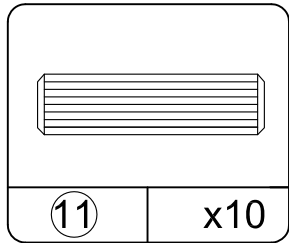
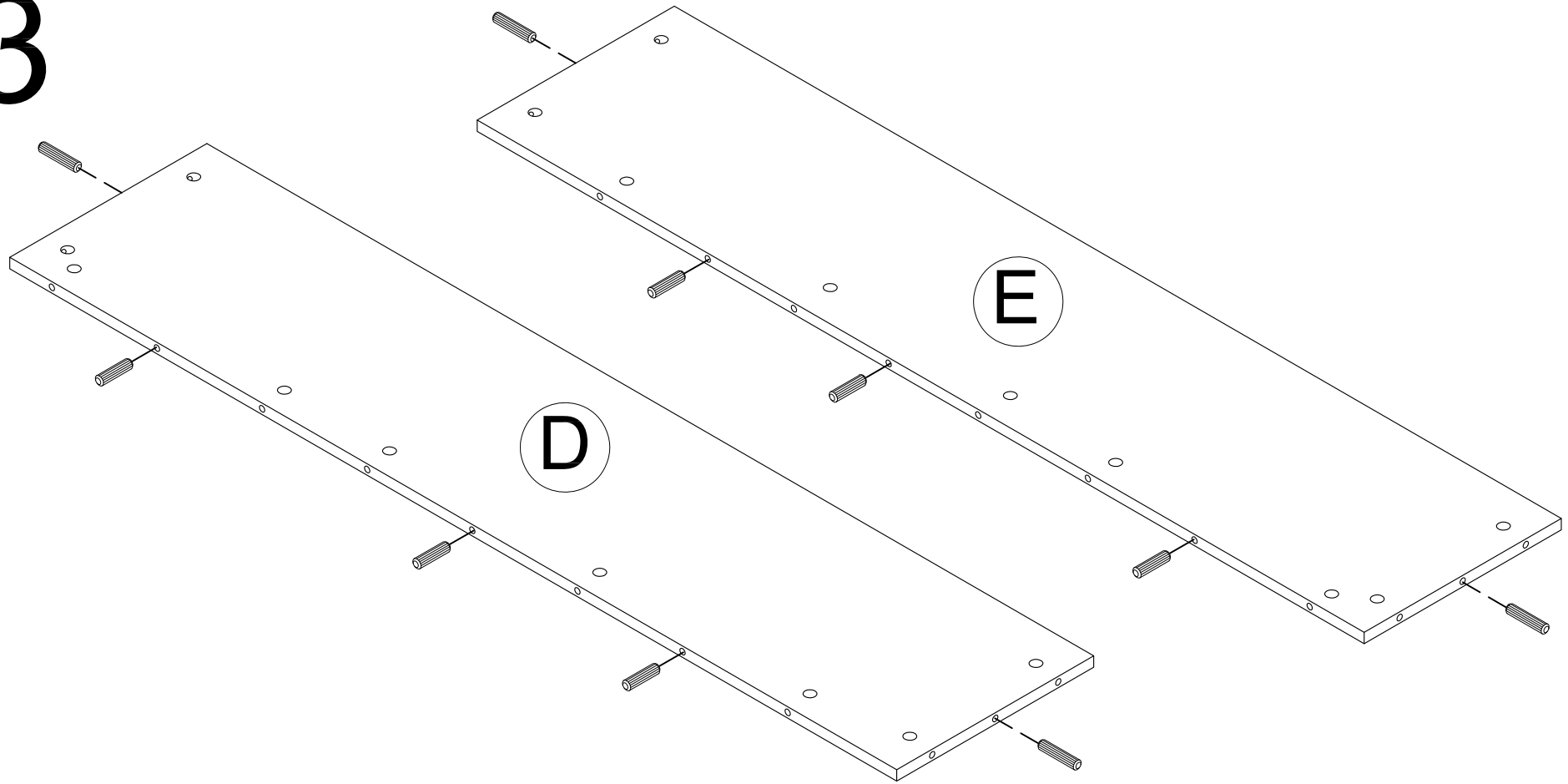

4

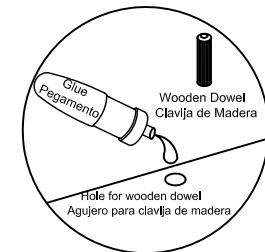
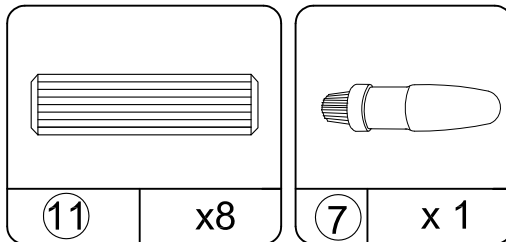
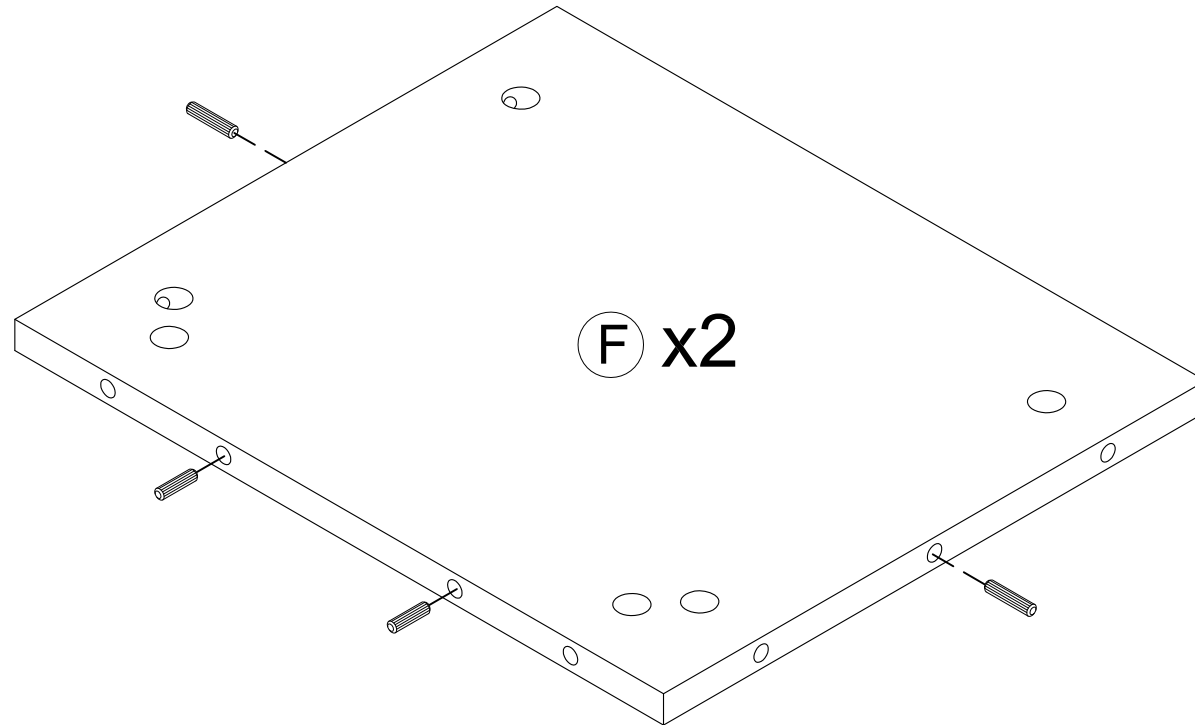

5

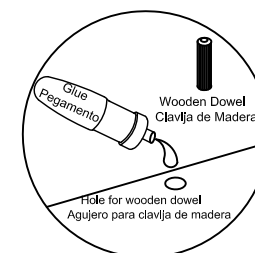
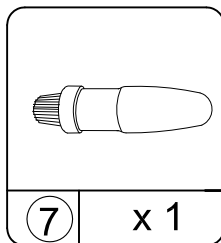
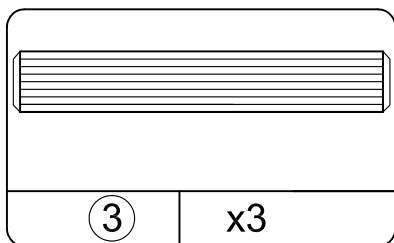
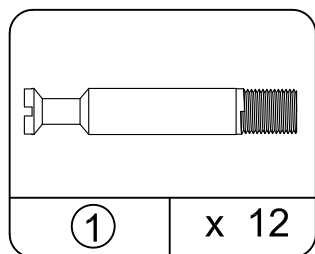
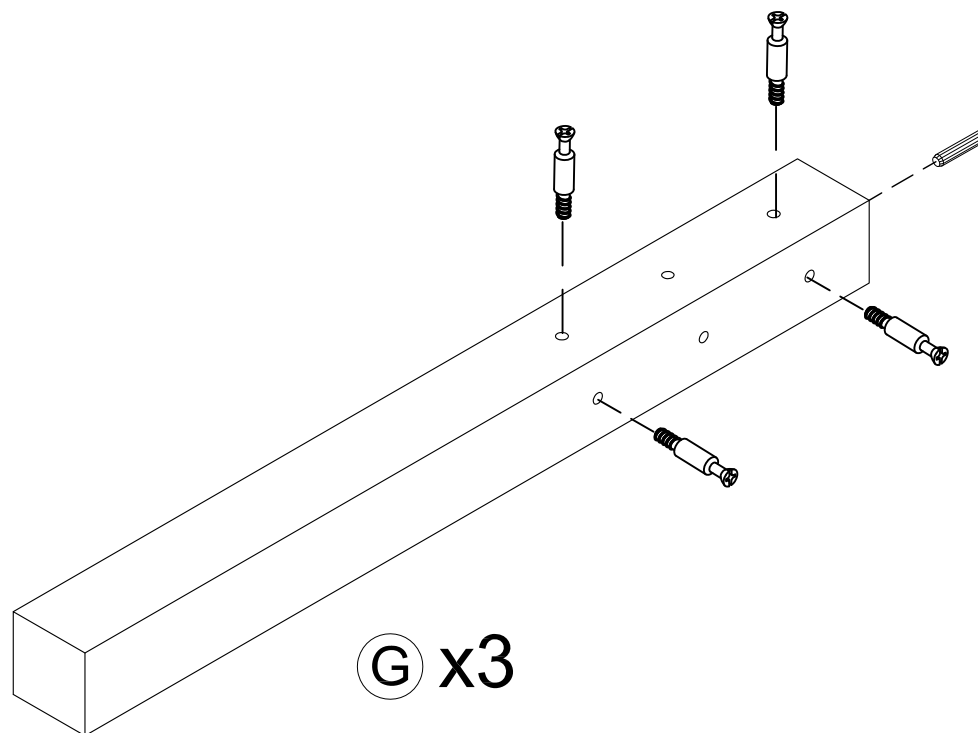

6

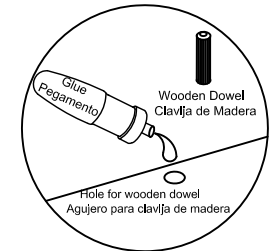
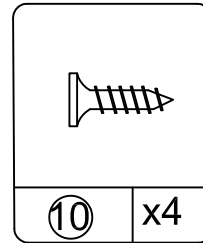
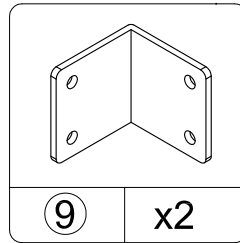
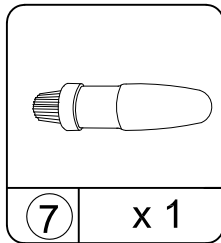
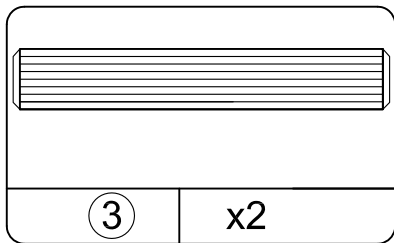
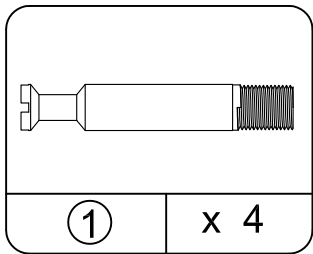
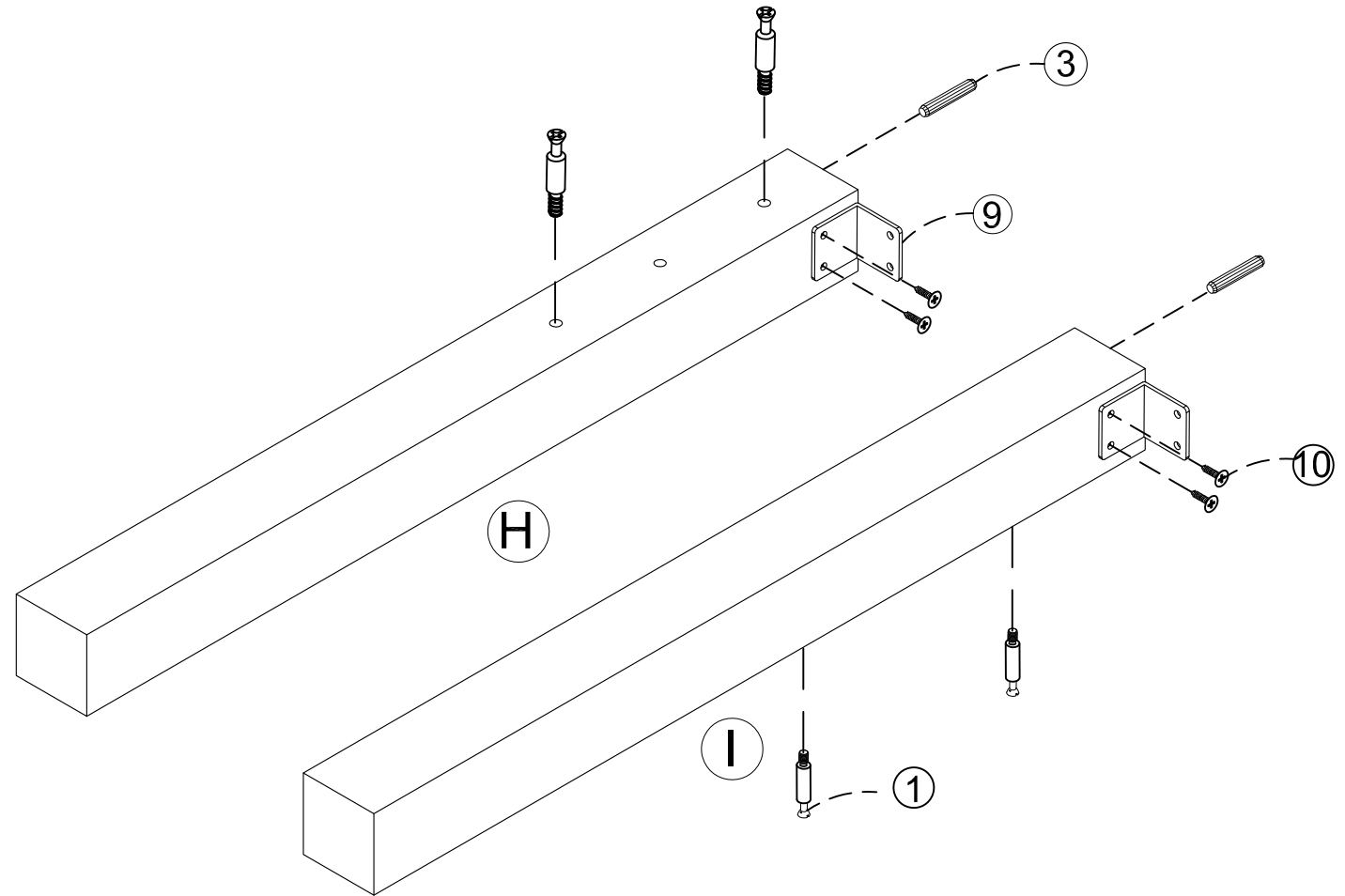

7

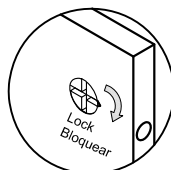
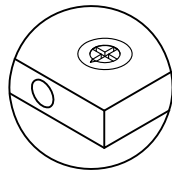
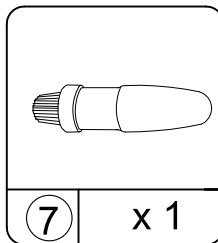
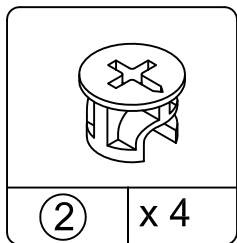
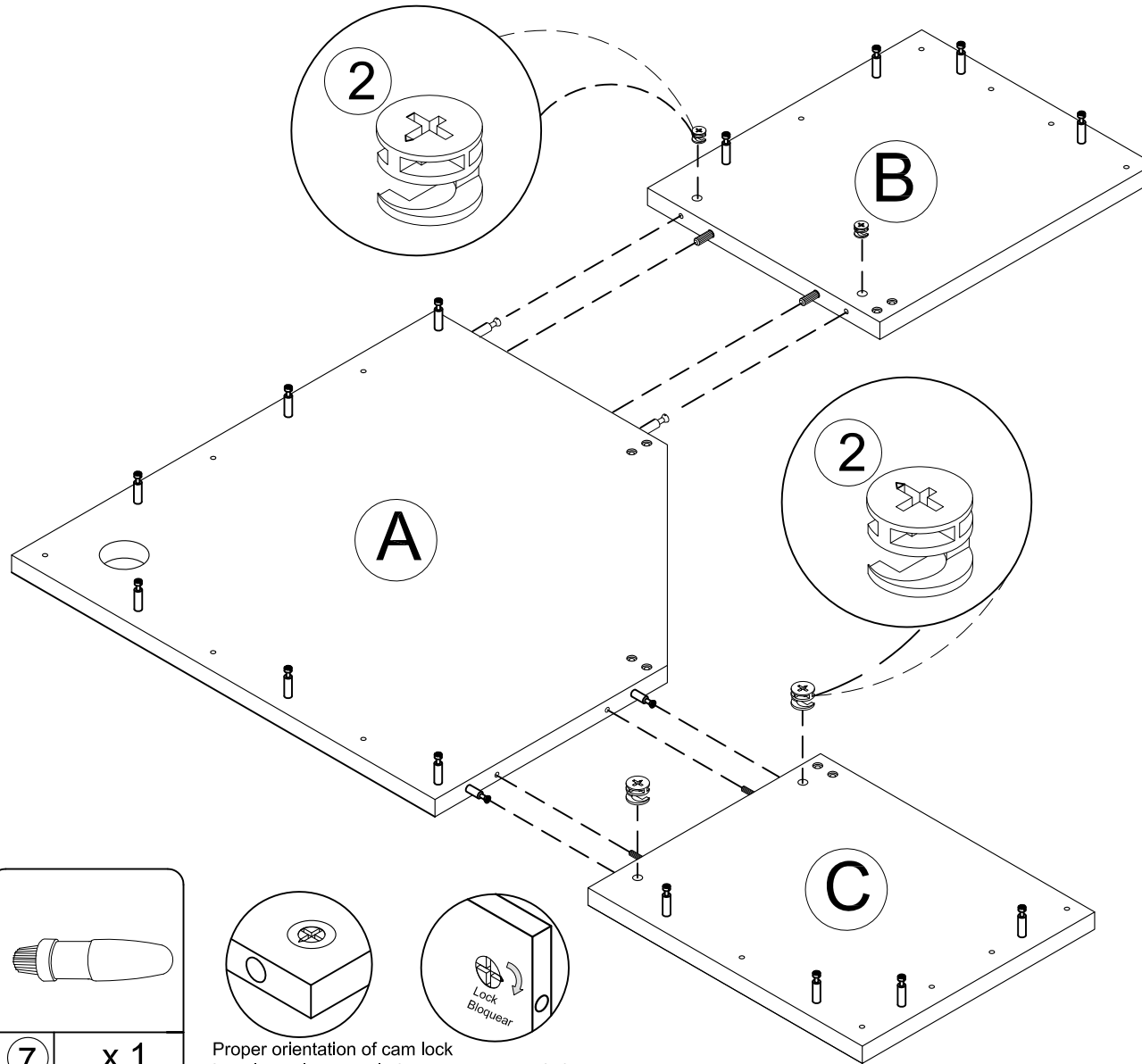

Proper orientation of cam lock
La orientación apropiada para el seguro de bloqueo

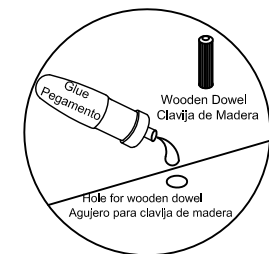

8

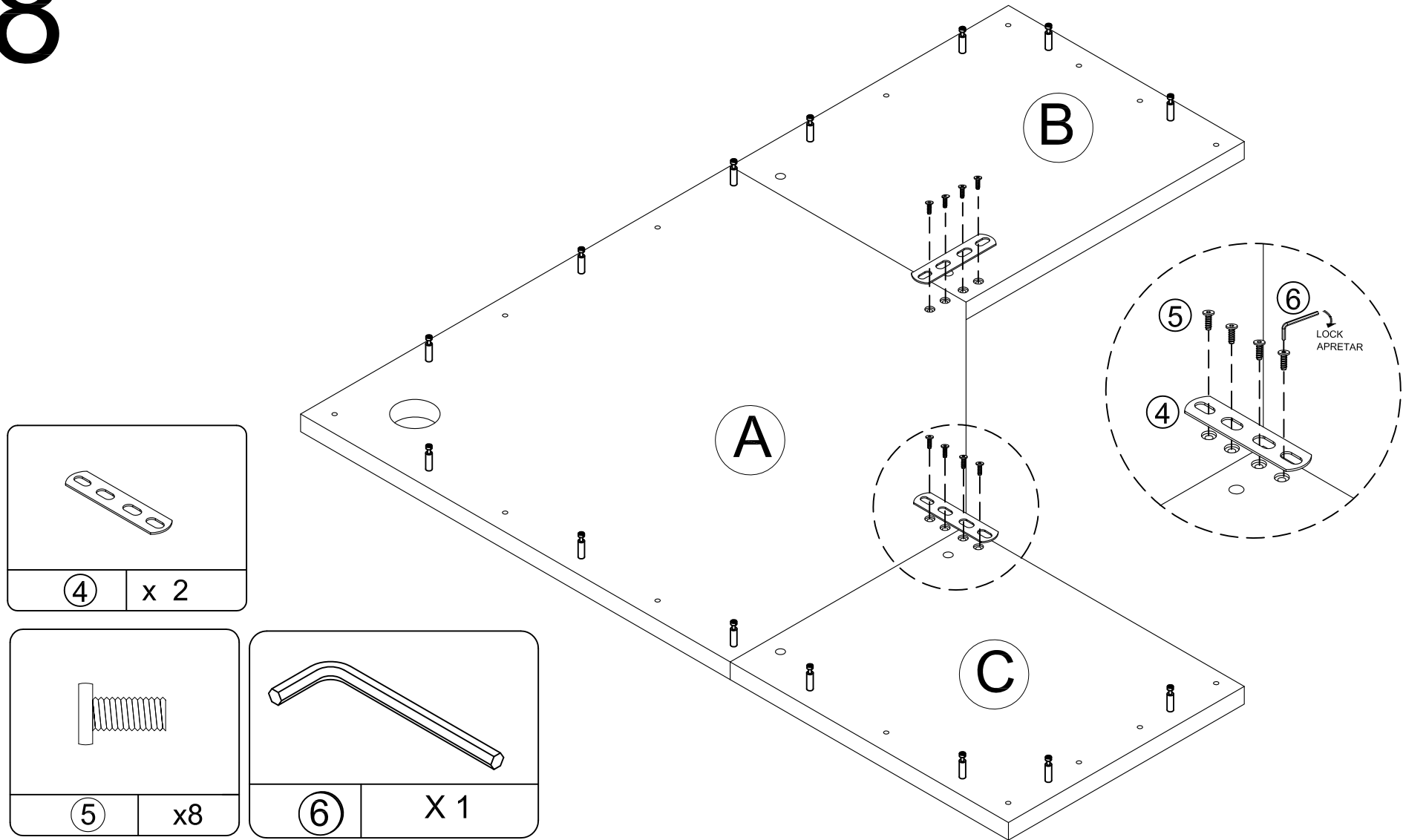

9

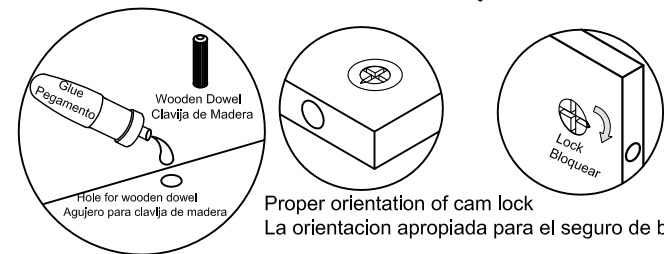
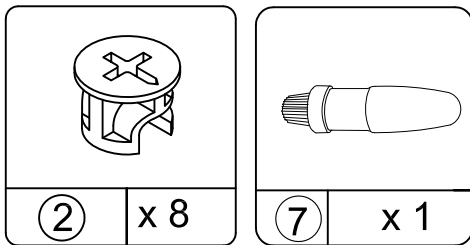
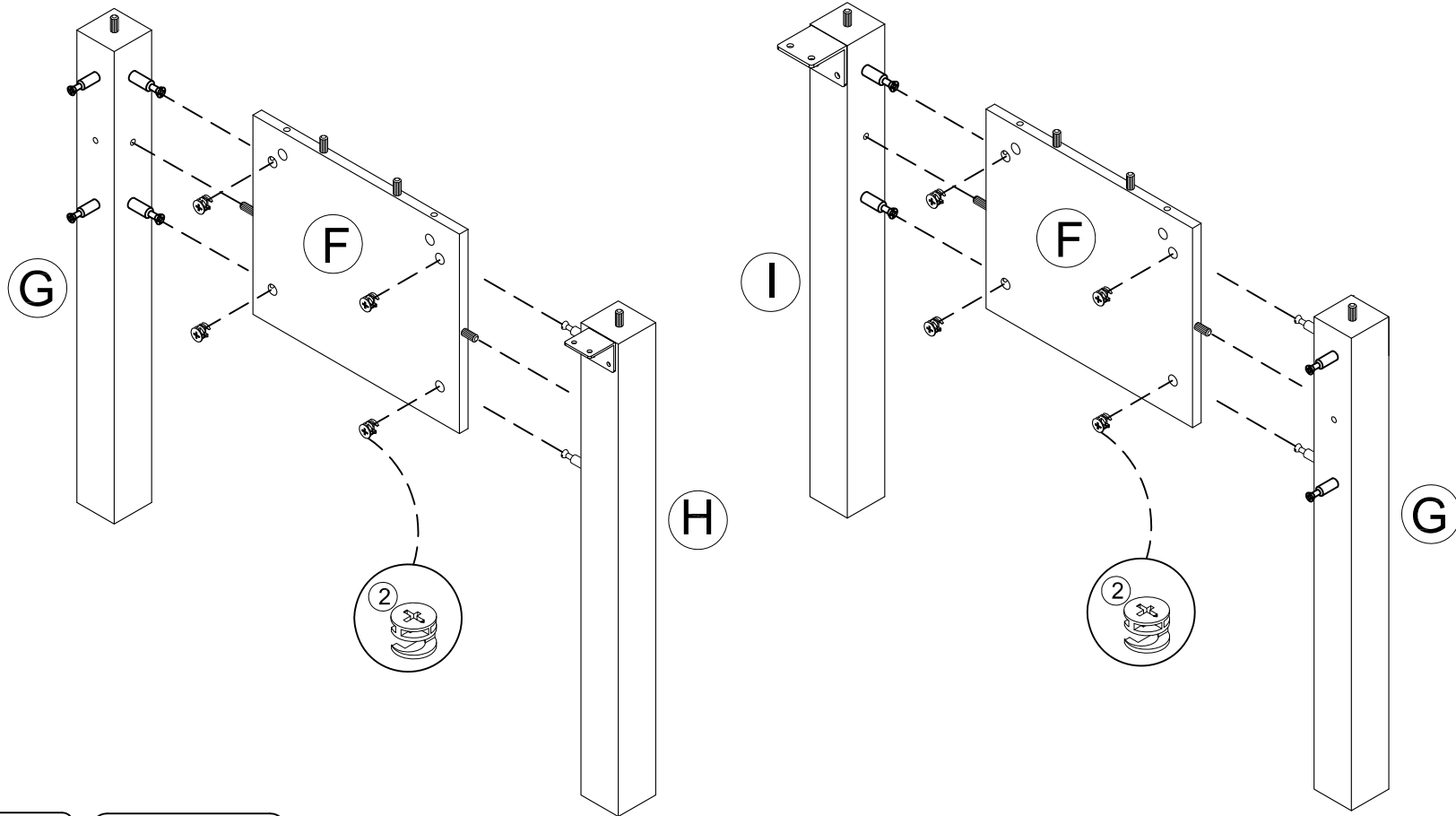

10

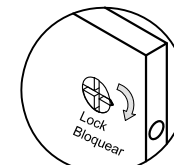
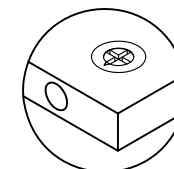
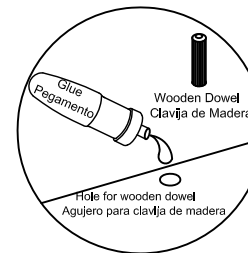
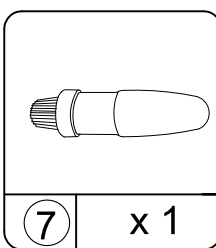
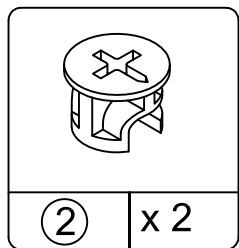
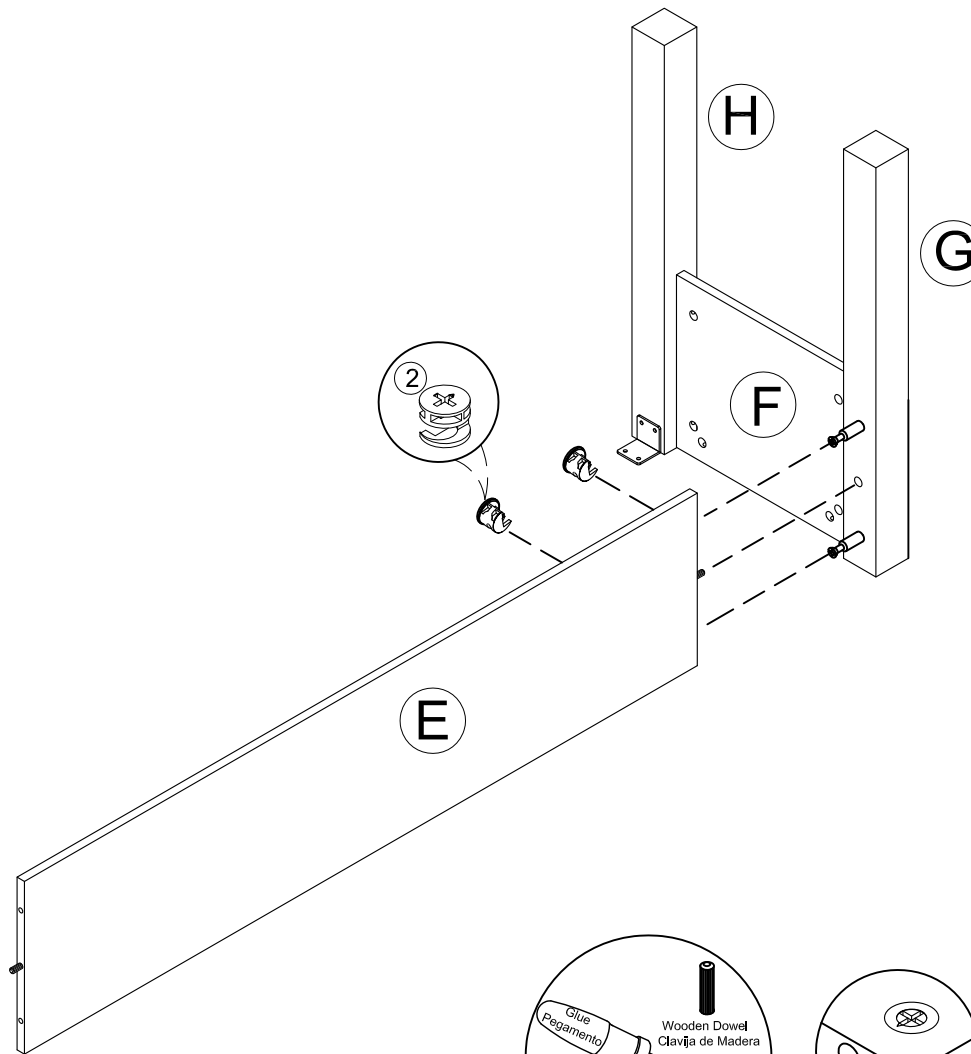

Proper orientation of cam lock
La orientación apropiada para el seguro de bloqueo

11

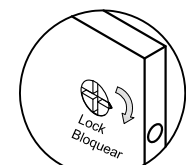
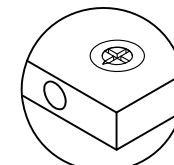
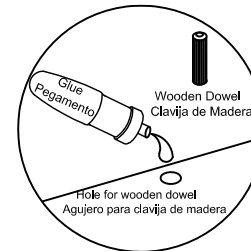
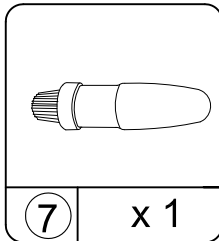
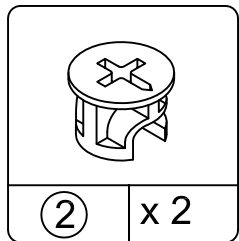
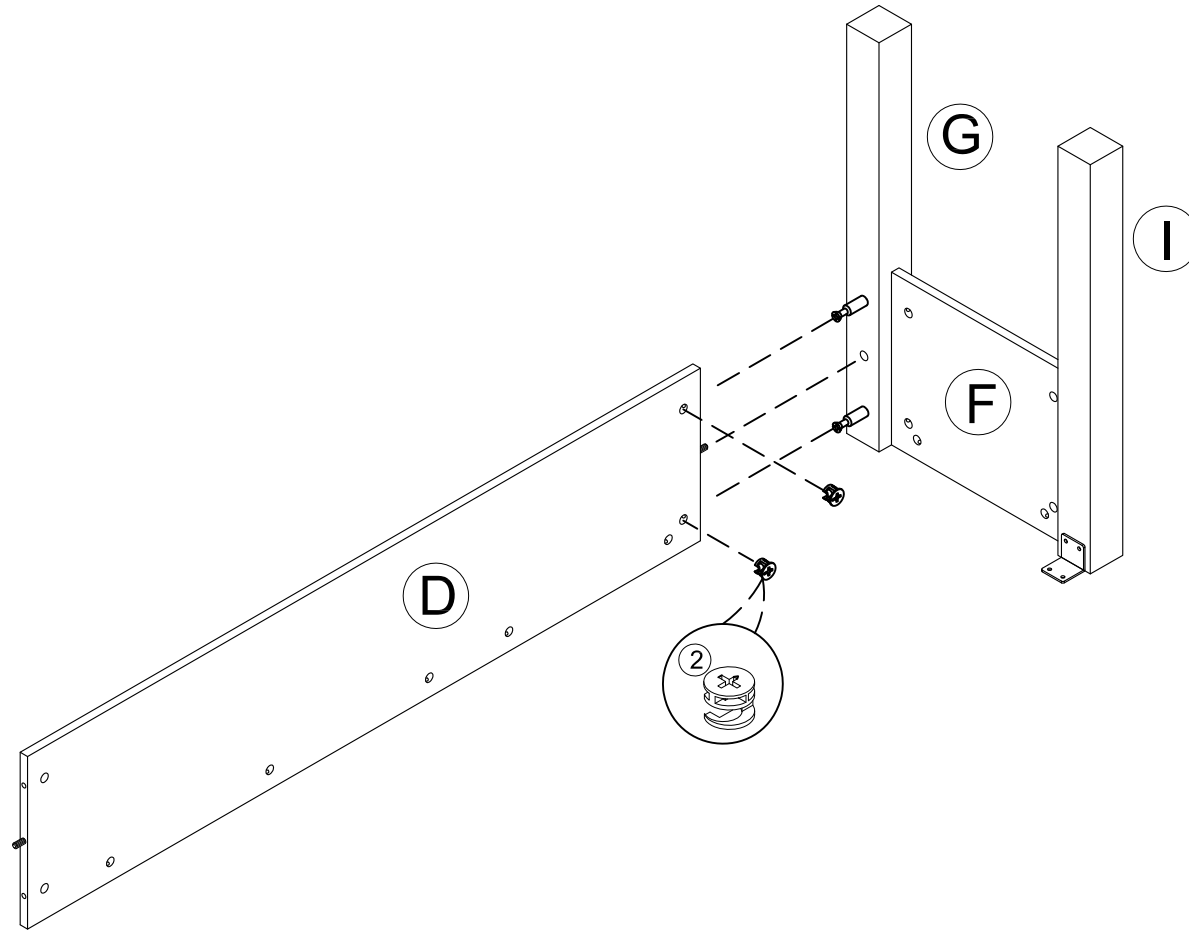

Proper orientation of cam lock
La orientación apropiada para el seguro de bloqueo

12

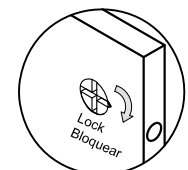
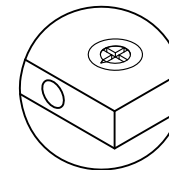
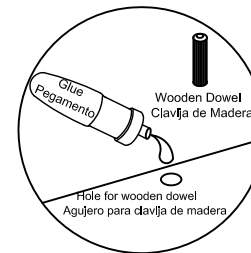
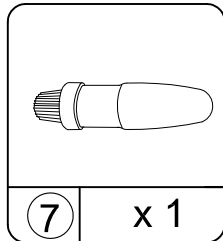
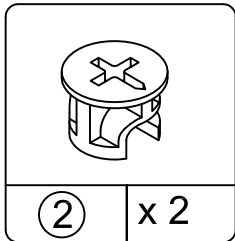
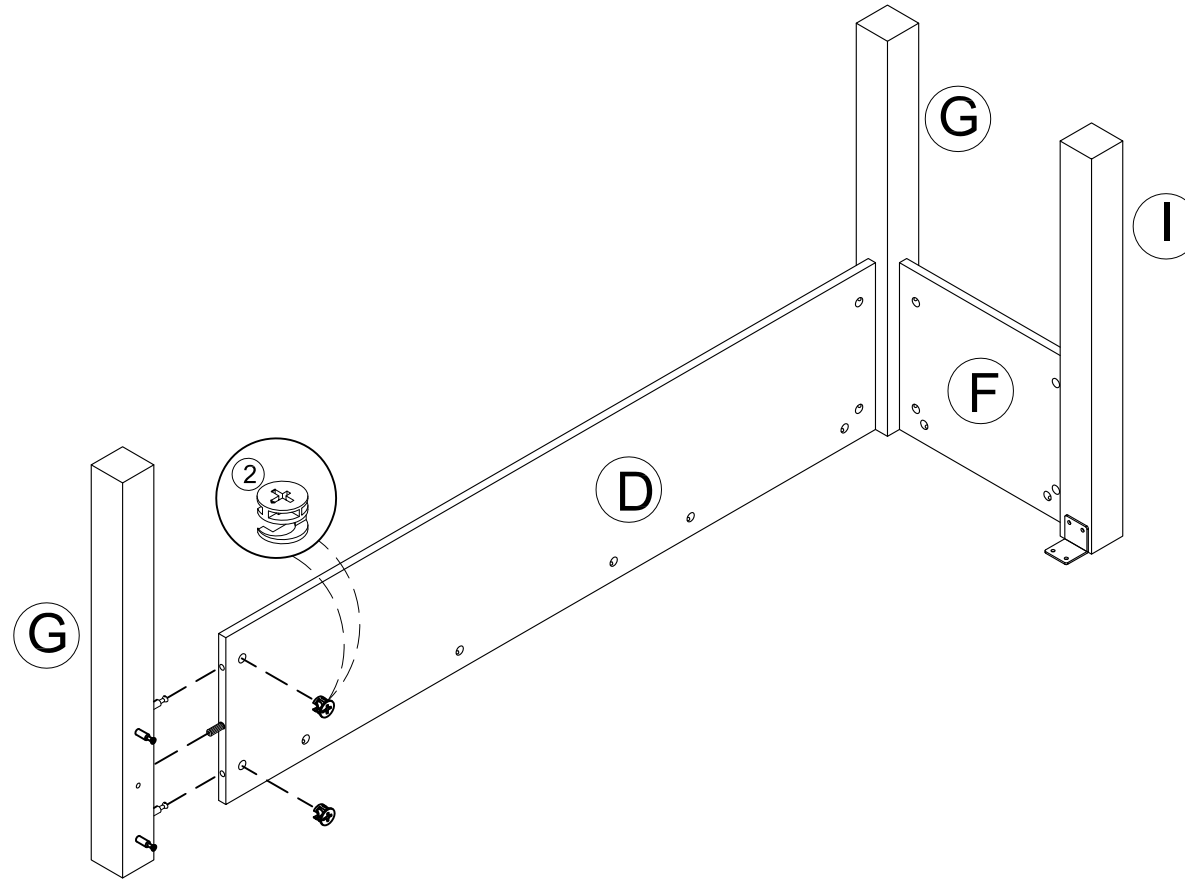

La orientación apropiada para el seguro de bloqueo

13

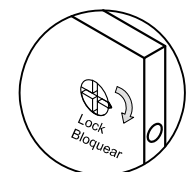
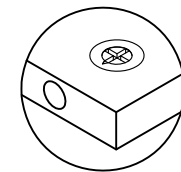
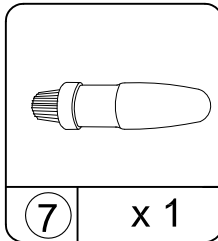
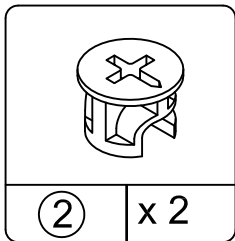
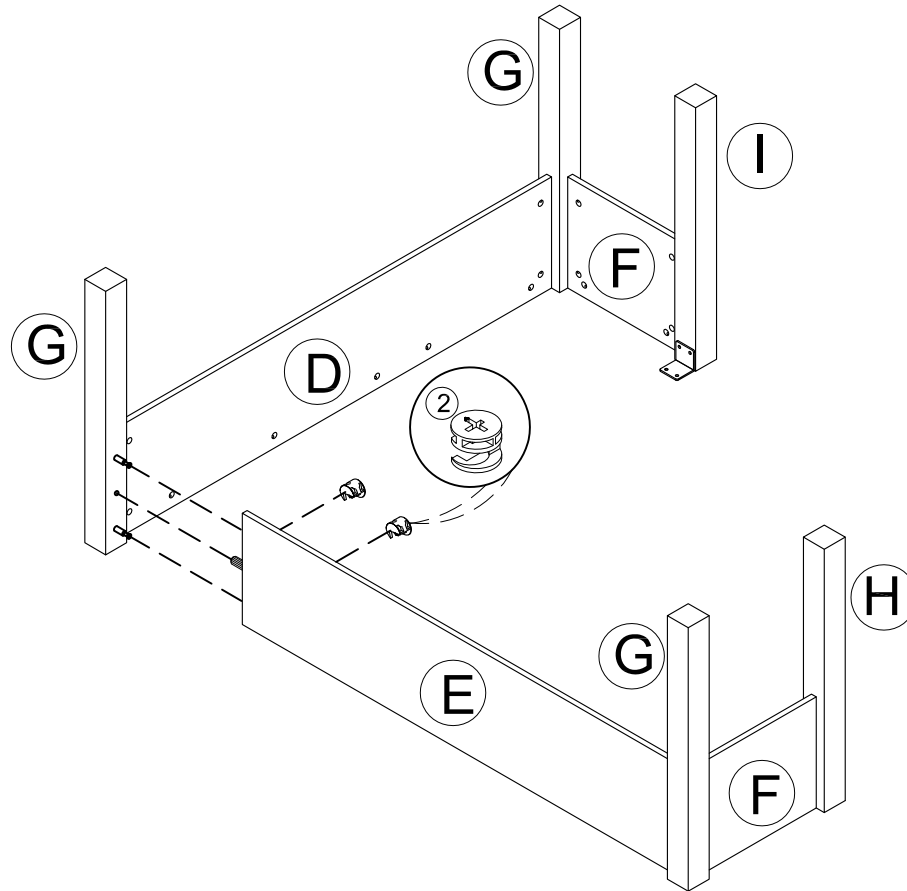
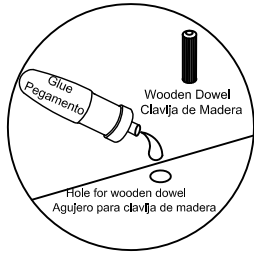

Proper orientation of cam lock
La orientación apropiada para el seguro de bloqueo

14

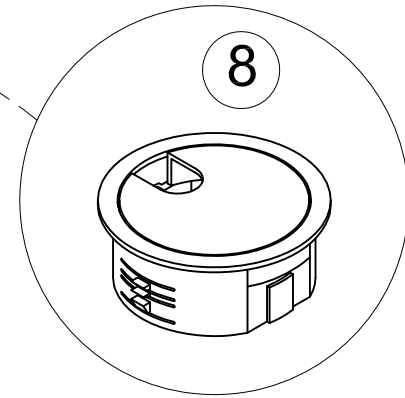
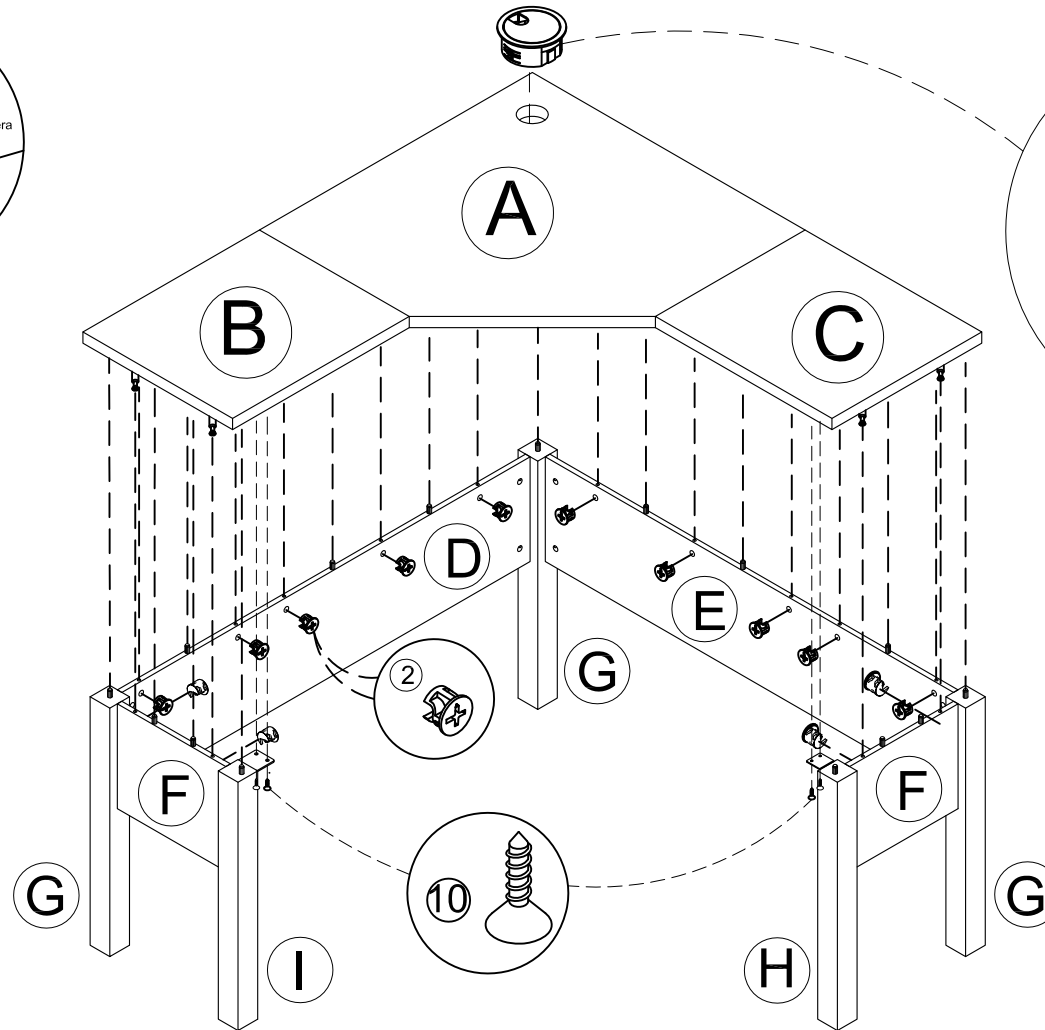
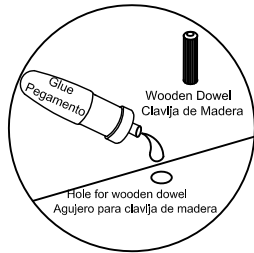

8 x1	10 x4
2 x14	7 x1

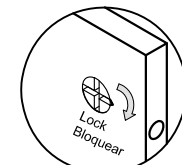
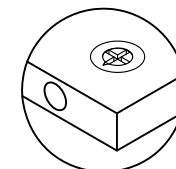

Proper orientation of cam lock
La orientación apropiada para el seguro de bloqueo

15

WEIGHT LIMITS:
LÍMITES DE PESO:

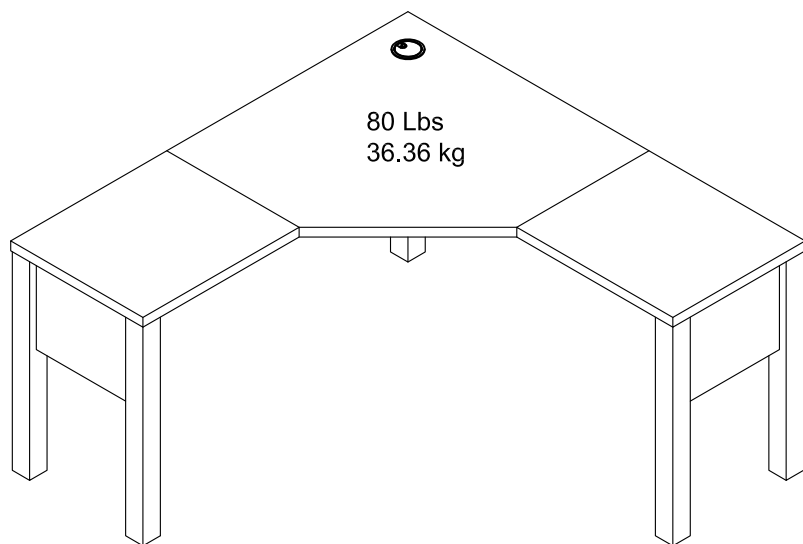

Enjoy Your Furniture
DISFRUTE DE SU MUEBLE

This unit has been designed to support the maximum loads shown.

Exceeding these load limits could cause sagging, instability, product collapse, and/or serious injury.

Esta unidad se ha diseñado para apoyar las cargas máximas mostradas.

Exceder estos límites de carga podría causar ceder, inestabilidad, derrumbamiento del producto, y/o lesión seria.

▲ WARNING

Please make sure that all objects are removed before moving the assembled unit.

The unit must be team lifted, not dragged or pushed. Failure to do so could cause instability, product collapse, and/or serious injury.

▲ ADVERTENCIA

Por favor mueva el mueble cuidadosamente con la ayuda de otra persona. Levante y mueva el mueble a su lugar. No lo arrastre o empuje, de lo contrario puede haber inestabilidad en el mueble y este puede colapsar u ocasionar graves lesiones.

PRODUCT RECOMMENDATION

Recomendación de Productos

Combine with matching Hutch - 9911096 (sold separately) for additional work center storage.

Combine con el Estante - 9911096 (se vende por separado) para almacenaje adicional.

Option 1
Opción 1

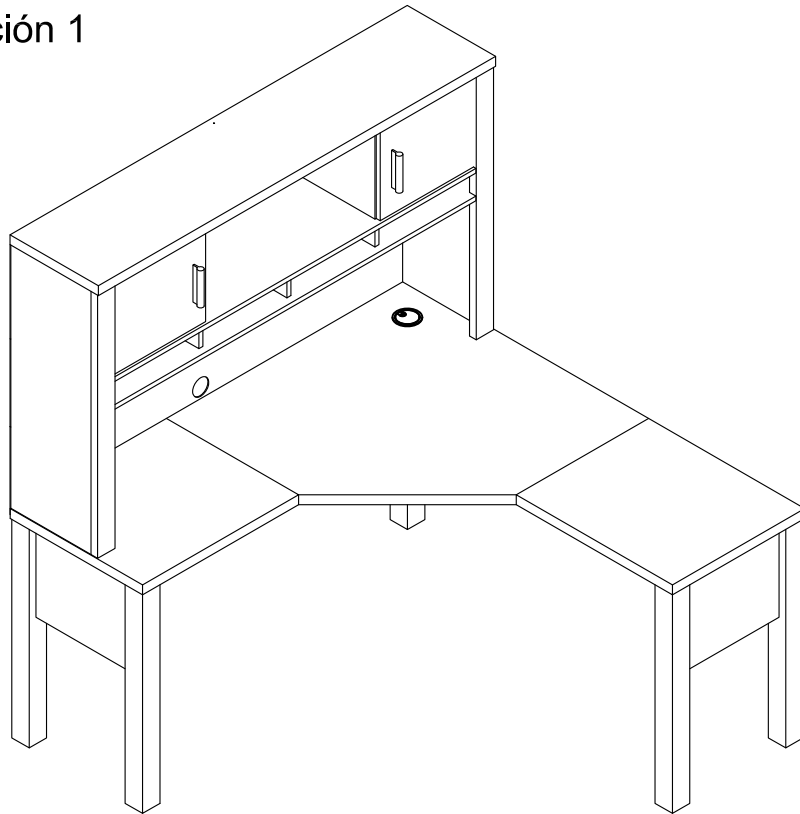

Option 2
Opción 2

