

深圳市天珑移动技术有限公司

Shenzhen Tinno Mobile Technology Corp.

**承 认 书**  
**( 电 池 类 )**  
**SPECIFICATION FOR APPROVAL**

物料描述 : U303AF 3.85V 2500mAh 锂离子电池/T/VK

**DESCRIBE:** U303AF 3.85V 2500mAh Lithium ion battery /T/VK

物料型号**PRODUCTS:** LT25H426271W

物料编码

**PART NO:** P104-BFT004-000

品牌(制造商):维科

**BRAND:** VEKEN

适用机种

**APPLICATION:**

日期

**DATE:**2020 年 4 月 25 日

供应商 :宁波维科电池有限公司

**PROVIDER:** Ningbo Veken Battery Co., Ltd.

APPROVED BY VENDOR			
确认 Confirm	校对 Proofread	审核 Audit	批准 Approval

Document number 文件编号: TN-WI-018 V1.1

Telephone : 0755-86095550 FAX: 0755-86095551

THE COPYRIGHT BELONGS TO TINNO MOBILE TECHNOLOGY CORP.

## 变更履历

版本	变更时间	页码	变更内容	审核
V1.0	2020-4-25		新版发行	张宇飞

## 目录

目录.....	3
一、 Technical specifications.....	4
1、 Scope of application 适用范围.....	4
2、 Battery specification 电池规格.....	4
3、 Test requirements 测试要求.....	6
4、 Electrical property 电性能.....	8
5、 Environmental performance 环境性能.....	10
6、 Safety protection performance 安全保护性能.....	12
7、 Cell safety performance 电芯安全性能.....	13
8、 List of main materials of battery 电池主要物料清单.....	15
9、 PCM parameters 保护板参数规格.....	17
10、 2D drawing 2D 图纸(TINNO 原图)及电芯图纸、原理图、标贴、爆炸图、包装说明图.....	18

## 一、 Technical specifications

### 技术规格部分

#### 1、 Scope of application 适用范围

This specification describes the battery's nominal parameters, electrical characteristics, safety performance, environmental adaptability, testing and determination, instructions for use and safety procedures, quality assessment and packaging, marking, storage, transportation, etc. It is suitable for supporting batteries made by weike 386267Ar cell and dongguan yongwei technology co., LTD.

本规格书描述电池之标称参数、电气特性、安全性能、环境适应性及其实验和判定、使用说明和安全规程、质量评定及包装、标志、贮存、运输等。适用于采用维科 386267Ar 电芯，东莞市甬维科技有限公司制成的配套电池。

#### 2、 Battery specification 电池规格

No.序号	Items 内 容	Specification 参 数	Note 备注
1	Nominal voltage 标称电压	3.85V	
2	Nominal capacity 标称容量	2500mAh t	Discharge to the capacity of cut-off voltage with 0.2c after full charge. 完全充电后用 0.2C 放电至截止电压的容量。
3	3.4V discharge time 3.4V 放电时间	≥270min	The time from 0.2c discharge to 3.4v after full charging. 完全充电后用 0.2C 放电至 3.4V 的时间。
4	Charging voltage 充电电压	4.40V	
5	Internal resistance 内 阻	110 mΩ (Max)	Half capacity 半电态
6	Charging way 充电方式	C.C/C.V. 恒流/恒压方式	Constant current/pressure Default battery voltage conversion 恒流/恒压 视电池电压转换
7	Charging way 充电方式	1. Standard charge 0.2C 1.标准充电 0.2C	Charging current 充电电流 500mA(0~60℃)
		2. Quick charge 0.7C 2.快速充电 0.7C	Charging current 充电电流 1750mA (10~45℃)

THE COPYRIGHT BELONGS TO TINNO MOBILE TECHNOLOGY CORP.

8	Charging time 充电时间	Standard c h a r g e 标准充电	≤8Hours	
		Q u i c k c h a r g e 快速充电	≤4.0 Hours	
9	Discharge cut-off voltage 放电截止电压	3.0V		
10	Overcharge protection voltage 过充电保护电压	4.475±0.02V		
11	Overdischarge protection voltage 过放电保护电压	2.5±0.035V		
12	Over discharge current protection 过电流保护	6.0A~ 12.0A		
13	Output short circuit protection 输出短路保护	Cancel short circuit load recovery after protection 保护后撤销短路负载恢复		
14	Working consumption current 工作消耗电流	6.0uA (Max)		
15	Precharge stream after overdischarge protection 过放保护后预充电流	0.02C		Charging current 充电电流 50mA
16	Working temperature 工作温度	When charging 充电时	0~10°C	0.3C CC and CV charging to 4.40v, cut-off current 0.02C 0.3C 恒流恒压充电至 4.4V, 截止电流 0.02C
			10~45°C	0.7C CC and CV charging to 4.40v, cut-off current 0.02C 0.7C 恒流恒压充电至 4.4V, 截止电流 0.02C
			45~60°C	0.5C CC and CV charging to 4.1v, cut-off current 0.02C 0.5C 恒流恒压充电至 4.1V, 截止电流 0.02C

		When discharge 放电时	0~60°C	1C constant current discharge to 3V 1C 恒流放电到 3.0V
			-20~0°C	0.2C constant current discharge to 3V 0.2C 到 3.0V
17	Storage temperature 贮存温度	-5°C-35°C recommended 推荐 (25 ±5°C)		Storage should be charged to 40%~50% of capacity 贮存时应充电至容量的 40%~50%
18	ID resistance ID 电阻	82K ±1%		
19	NTC resistance NTC 电阻.	10K Ω ±1%		B 值 3435 25°C
20	0V charging function 0V 充电功能	有		
21	Cycle life 循环寿命	400 次 ≥80%标称容量		
22	Gold plating thickness 五金镀金厚度	≥0.2um		
23	Nickel plating thickness 五金镀镍厚度	≥6um		
24	Shipment voltage 出货电压要求	3.93-4.0V		
25	Battery thickness (Shipment voltage) 电池厚度 (出货电压)	4.2 ±0.1 mm		
26	Battery thickness (full charge) 电池厚度 (满电)	Max4.53mm		
27	Battery thickness (after cycle) 电池厚度 (循环后)	Max4.73mm		
28	Battery weight 成品电池重量	42.3g		

### 3、Test requirements 测试要求

Supplier is required to test battery before shipping, including but not limited to the key evaluation items in this standard, adding test results to the specification. Test report of each test shall be provided in the required format. Reliability test must have photos of product before and after test or test video.

**THE COPYRIGHT BELONGS TO TINNO MOBILE TECHNOLOGY CORP.**

According to the battery test standards in this specification, periodic test shall be conducted for first sample certification test of each newly developed project and the project in mass production. Please provide test report according to time nodes described in TINNO's Lithium Ion Battery Certification Standard.

要求供应商对电池进行出厂前测试，测试项包含但不限于本标准中的关键评估项，并在规格书中附加测试结果。各项测试的测试报告需按照要求格式提供。可靠性测试必须附加测试前后的照片或测试视频。

按照本规范描述的电池测试标准，对于每一个新研发项目的首次签样认证测试和已经量产的项目电池进行周期性测试。测试报告提供时间节点请参考天玑公司的《锂离子电池认证标准》。

### 3.1 Standard test conditions 标准测试条件:

Unless otherwise specified, all tests in this standard shall be carried out under standard atmospheric conditions:

Temperature: 23 °C + 2 °C

Relative humidity: 45% ~ 75%

Atmospheric pressure: 86kPa ~ 106kPa

除非另有规定，本标准中各项试验应在试验的标准大气条件下进行：

温度：23°C±2°C

相对湿度：45%~75%

大气压力：86kPa~106kPa

### 3.2 Requirements for measuring instruments and equipment

#### 测量仪表与设备的要求:

Accuracy of voltage meter should be not less than 0.5. Its resistance range should not be less than 10 k/V.

The accuracy of the instrument for measuring current should not be less than 0.5.

The accuracy of the meter used for measuring time should not be less than ±0.1%.

The accuracy of the instrument used for temperature measurement should not be less than ±0.5°C.

Constant current source's current is constant and adjustable. In constant current state, current's change range is ±0.5%.

Constant voltage source's voltage is constant and adjustable. In constant voltage state, voltage's change range is ±0.5%.

The accuracy of measuring instrument should not be less than 0.01mm.

The accuracy of weighing instrument shall not be less than 0.1mg.

测量电压的仪表准确度应不低于 0.5 级，内阻量程应不小于 10 kΩ/V。

测量电流的仪表准确度应不低于 0.5 级。

测量时间用的仪表准确度应不低于 ±0.1%。

测量温度用的仪表准确度应不低于 ±0.5°C。

恒流源的电流恒定可调，恒流时，其电流变化范围为 ±1%。

恒压源的电压恒定可调，恒压时，其电压变化范围为 ±0.5%。

测量尺寸用的仪器准确度应不低于 0.01mm。

测量重量用的仪器准确度应不低于 0.1mg。

### 3.3 Standard charging mode 标准充电模式

Standard charging: under 23°C±2°C, battery is charged to 4.4V at a constant current of 0.2C<sub>5A</sub>, and then is charged at a constant voltage of 4.4V until current is less than 0.02C<sub>5A</sub>.

标准充电：即在环境温度为 $23^{\circ}\text{C}\pm 2^{\circ}\text{C}$ 的条件下,先以恒定电流 $0.2\text{C}_5\text{A}$ 充电至 $4.4\text{V}$ ,再以 $4.4\text{V}$ 的恒压充电至电流小于 $0.02\text{C}_5\text{A}$ 。

### 3.4 Quick charging mode 快速充电模式

Quick charging: under  $23^{\circ}\text{C}\pm 2^{\circ}\text{C}$ , battery is charged to  $4.4\text{V}$  at a constant current of  $0.7\text{C}_5\text{A}$ , and then is charged at a constant voltage of  $4.4\text{V}$  until current is less than  $0.02\text{C}_5\text{A}$ .

快速充电：即在环境温度为 $23^{\circ}\text{C}\pm 2^{\circ}\text{C}$ 的条件下,先以恒定电流 $0.7\text{C}_5\text{A}$ 充电至 $4.4\text{V}$ ,再以 $4.4\text{V}$ 的恒压充电至电流小于 $0.02\text{C}_5\text{A}$ 。

### 3.5 Discharge 放电

The cut-of voltage of discharge is  $3.0\text{V}$ , the standard discharge current is  $0.2\text{C}_5\text{A}$ , and the maximum constant discharge current is  $1\text{C}$

放电终止电压为 $3.0\text{V}$ , 标准放电电流 $0.2\text{C}_5\text{A}$ , 最大恒流放电电流为 $1\text{C}$ 。

## 4、Electrical property 电性能

Test item 测试项目	Test method 测试方法	Standard 检验标准
Nominal capacity 额定容量	After the battery is fully charged according to the standard charging mode, it is put aside for 10 minutes, and then discharged at $0.2\text{C}$ to $3.0\text{V}$ . Discharge time should be not less than 5h. 电池按照标准充电模式充满电后搁置10分钟, 以 $0.2\text{C}$ 放电至 $3.0\text{V}$ , 要求放电时间不低于5h。	Discharge time should be not less than 5h. 放电时间不低于5h。
Effective capacity 有效容量	After the battery is fully charged according to the standard charging mode, it is put aside for 10 minutes, and then discharged at $0.2\text{C}$ to $3.4\text{V}$ . 电池按照标准充电模式充满电后搁置 10 分钟, 以 $0.2\text{C}$ 放电至 $3.4\text{V}$	$3.4\text{V} / 3.0\text{V}$ capacity rate $\geq 90\%$ $3.4\text{V}/3.0\text{V}$ 容量比例 $\geq 90\%$
Discharge performance 放电性能	The battery should be fully charged in the standard charging mode and put aside for 10 minutes. , battery should be discharged at $0.5\text{C}$ to $3.0\text{V}$ . 电池按照标准充电模式充满电后搁置 10 分钟, 以 $0.5\text{C}$ 放电至 $3.0\text{V}$	$0.5\text{C}$ discharge time should be no less than 110min $0.5\text{C}$ 放电时间不低于 110min
High temperature discharge capacity 高温放电容量	After the battery is fully charged in accordance with the standard charging mode, the battery is placed in a high temperature box at $55^{\circ}\text{C}\pm 2^{\circ}\text{C}$ to be stored at this temperature for 2h, and then discharged at a current of $0.2\text{C}_5$ to the cut-off voltage of $3.0\text{V}$ . The battery is removed out and stored for 2h under $23^{\circ}\text{C}\pm 2^{\circ}\text{C}$ . Finally, battery appearance is visually checked. 电池按照标准充电模式充满电后, 将电池放入 $55^{\circ}\text{C}\pm 2^{\circ}\text{C}$ 的高温箱中恒温2h, 然后以 $0.2\text{C}_5$ 电流放电至终止电压 $3.0\text{V}$ , 将电池取出在环境温度为 $23^{\circ}\text{C}\pm 2^{\circ}\text{C}$ 的条件下搁置2h, 然后目测电池外观。	The discharge time is required to be no less than 5h, battery's swelling rate $\leq 5\%$ , and no obvious appearance difference before and after test. 放电时间不低于5h, 电池厚度变化率 $\leq 5\%$ , 电池外观相比实验前无明显差异。



<p>Low temperature discharge capacity</p> <p>低温放电容量</p>	<p>After the battery is fully charged in accordance with the standard charging mode, the battery is placed in a low-temperature box at <math>-10^{\circ}\text{C}\pm 2^{\circ}\text{C}</math> to be stored at this temperature for 4h, and then discharged at 0.2C5 until voltage reaches 3.0V.</p> <p>电池按照标准充电模式充满电后，将电池放入<math>-10^{\circ}\text{C}\pm 2^{\circ}\text{C}</math>的低温箱中恒温 4h，然后以 0.2C 电流放电至终止电 3.0V。</p>	<p>The discharge time is required to be no less than 3.5h. No obvious appearance difference before and after test.</p> <p>放电时间<math>\geq 3.5\text{h}</math>，电池外观相比实验前无明显差异</p>
<p>Low temperature discharge capacity</p> <p>低温放电容量</p>	<p>After the battery is fully charged in accordance with the standard charging mode, the battery is placed in a low-temperature box at <math>-20^{\circ}\text{C}\pm 2^{\circ}\text{C}</math> to be stored at this temperature for 4h, and then discharged at 0.5C5 until voltage reaches 3.3V.</p> <p>电池按照标准充电模式充满电后，将电池放入<math>-20^{\circ}\text{C}\pm 2^{\circ}\text{C}</math>的低温箱中恒温 4h，然后以 0.5C 电流放电至 3.3V。</p>	<p>Discharge capacity <math>\geq 0\text{mAh}</math>. No obvious appearance difference before and after test.</p> <p>放电容量<math>\geq 0\text{mAh}</math>，电池外观相比实验前无明显差异</p>
<p>Battery's internal resistance</p> <p>电池内阻</p>	<p>Under <math>23^{\circ}\text{C}\pm 2^{\circ}\text{C}</math>, internal resistance of battery with SOC 50% is tested.</p> <p>在 <math>23^{\circ}\text{C}\pm 2^{\circ}\text{C}</math> 的条件下，测试半电态电池内阻</p>	<p>internal resistance <math>&lt; 110\text{ m}\Omega</math> (50%SOC).</p> <p>电池内阻<math>&lt; 110\text{m}\Omega</math> (半荷电状态)。</p>
<p>NTC resistance</p> <p>NTC 电阻</p>	<p>The required accuracy of NTC resistance is <math>10\text{ k}\pm 1\%</math>. Battery is put in the constant temperature box in <math>-10^{\circ}\text{C}</math>, <math>-5^{\circ}\text{C}</math> and <math>0^{\circ}\text{C}</math>, <math>25^{\circ}\text{C}</math>, <math>45^{\circ}\text{C}</math> and <math>55^{\circ}\text{C}</math>, <math>60^{\circ}\text{C}</math> to be storage for 45 min with temperature and NTC resistance (unit <math>\text{k}\Omega</math>) be recorded. The distance between NTC resistance and MOSS or other heating devices on the protection board should be more than 5 mm. NTC model is selected according to the instruction.</p> <p>NTC 电阻精度要求 <math>10\text{k}\pm 1\%</math>，把电池放在恒温箱里在 <math>-10^{\circ}\text{C}</math>，<math>-5^{\circ}\text{C}</math>，<math>0^{\circ}\text{C}</math>，<math>25^{\circ}\text{C}</math>，<math>45^{\circ}\text{C}</math>，<math>55^{\circ}\text{C}</math>，<math>60^{\circ}\text{C}</math> 环境下存储 45min，并分别记录各温度下的 NTC 阻值 (单位 <math>\text{k}\Omega</math>)，NTC 电阻在保护板上的位置需要避免放置在 MOSS 等发热器件旁边，距离要求 5mm 以上，NTC 按照指定型号选用。</p>	<p>The resistance value should meet technical requirements.</p> <p>阻值符合技术要求规定</p>
<p>Cycle performance</p> <p>循环性能</p>	<p>under <math>23^{\circ}\text{C}\pm 2^{\circ}\text{C}</math>, battery is discharged at 0.5 C to cut-off voltage, and put aside for 10 minutes. Then it is charged at 0.5C to the limiting voltage and cut-off current of 0.02C, and stored for 10 minutes. Repeating the above steps to cycle battery.</p> <p>在环境温度为 <math>23^{\circ}\text{C}\pm 2^{\circ}\text{C}</math> 时，电池用 0.5 C 放电放电至终止电压，搁置 10 分钟；再以 0.5C 充电至限制电压，截止电流 0.02 C；搁置 10 分钟；再按照上述步骤进行下一个充放电循环</p>	<p>400 cycles capacity retention rate <math>\geq 80\%</math></p> <p>Swelling rate <math>\leq 8\%</math>.</p> <p>No obvious difference on battery surface before and after test.</p> <p>400 次循环容量保持率<math>\geq 80\%</math>，电池厚度变化率<math>\leq 8\%</math>，电池外观相比实验前无明显差异</p>

<p>Room temperature charge retention capacity 常温荷电保持能力</p>	<p>After fully charging in accordance with standard charging mode, the battery is stored for 28 days under <math>23\pm 5^{\circ}\text{C}</math>. Then, under <math>23^{\circ}\text{C}\pm 2^{\circ}\text{C}</math>, it is discharged to 3.0V at 0.2C. Recording discharge time T1. Then, the battery was filled in the standard charging mode. Under <math>23^{\circ}\text{C}\pm 2^{\circ}\text{C}</math>, the battery was discharged from 0.2C to 3.0v. Recording discharge time T2. Checking battery appearance.</p> <p>电池按照标准充电模式充满电后，电池在 <math>23\pm 5^{\circ}\text{C}</math> 条件下，开路搁置 28 天；在环境温度为 <math>23^{\circ}\text{C}\pm 2^{\circ}\text{C}</math> 下，以 0.2 C5 放电至 3.0V，记录放电时间 T1；然后再将电池按照标准充电模式充满，在环境温度为 <math>23^{\circ}\text{C}\pm 2^{\circ}\text{C}</math> 下，以 0.2 C5 放电至 3.0V，记录放电时间 T2，检查电池外观。</p>	<p>T1 <math>\geq 4.25\text{h}</math>, T2 <math>\geq 4.5\text{h}</math> No swelling or leakage. 电池不膨胀、不渗漏。</p>
<p>High temperature charge retention capacity 高温荷电保持能力</p>	<p>After fully charging in accordance with standard charging mode, it is stored in the oven under <math>45^{\circ}\text{C}\pm 2^{\circ}\text{C}</math> for 7 days. The battery is removed out to be put aside for 2 hours, then is discharged at 0.2C5 to the cut-off voltage of 3.0v.</p> <p>电池按照标准充电模式充满电后，放入 <math>45^{\circ}\text{C}\pm 2^{\circ}\text{C}</math> 的烘箱中存放 7 天；从恒温箱中取出电池恢复 2 小时，然后以 0.2C5 放电至终止电压 3.0V。</p>	<p>Discharge time <math>\geq 4.5\text{h}</math>, swelling rate <math>\leq 5\%</math>. No swelling or leakage. 放电时间 <math>\geq 4.5\text{h}</math>，电池厚度变化率 <math>\leq 5\%</math>，检查电池外观，电池不膨胀、不渗漏。</p>

## 5、Environmental performance 环境性能

测试项目	测试方法 Method	检验标准 Criteria
<p>Constant humidity and heat performance 恒定湿热性能</p>	<p>After standard charging, the battery is put into a constant humidity box with a temperature of <math>40\pm 2^{\circ}\text{C}</math> and a relative humidity of 90%~95% to be stored for 48h. The battery is removed and stored for 2 hours at an ambient temperature of <math>23^{\circ}\text{C}\pm 2^{\circ}\text{C}</math> to check its appearance. Then it is discharged at a current of 0.2A until reaching cut-off voltage of 3.0V</p> <p>电池标准充电后放入温度 <math>40\pm 2^{\circ}\text{C}</math>、相对湿度 (90%~95%) 的恒温箱中搁置 48h，将电池取出在 <math>23^{\circ}\text{C}\pm 2^{\circ}\text{C}</math> 的环境温度下搁置 2 小时，检查电池外观，然后以 0.2C5 电流放电至终止电压 3.0V。</p>	<p>The discharge time of residual capacity shall be <math>\geq 4.5\text{h}</math>, swelling rate <math>\leq 5\%</math>. No swelling or leakage. 剩余容量放电时间 <math>\geq 4.5\text{h}</math>，电池厚度变化率 <math>\leq 5\%</math>、电池不膨胀、不渗漏；</p>
<p>ESD test ESD 测试</p>	<p>After battery standard charging, 8KV is used to conduct contact discharge at the battery. Battery is continuously discharge for 10 times, with an interval of 1s. 12KV is used to conduct air discharge on the weak insulation position of the battery. Battery is continuously discharge for 10 times, with an interval of 1s. 电池标准充电后，使用 8KV 对电池的每个金属接触点进行接触放电；连续进行 10 次放电，每次放电间隔时间为 1s。继续使用 15KV 对电池较薄弱的绝缘位置进行空气放电；连续进行 10 次放电，每次放电间隔时间为 1s。</p>	<p>Battery has no abnormality and the electrical performance is normal. 要求电池无异常，电性能正常</p>

<p>Low pressure 低气压</p>	<p>After standard charging, the battery was placed in a vacuum box at an ambient temperature of <math>23^{\circ}\text{C}\pm 2^{\circ}\text{C}</math>. After the box was closed, the internal pressure was gradually reduced to no more than 11.6kpa. Battery is stored in such environment for 6h. Then it is taken out to be placed in an open circuit for 1h. (simulated altitude of 15240m)</p> <p>电池标准充电结束后, 在 <math>23^{\circ}\text{C}\pm 2^{\circ}\text{C}</math> 的环境温度下, 将其搁置在真空箱中, 真空箱密闭后, 逐渐减少其内部压力至不高于 11.6kPa, 开路放置 6h (模拟海拔 15240m), 然后取出电池, 开路搁置 1h, 观察电池状态。</p>	<p>No obvious damage, no swelling, no leakage, no venting, no crack, no fire, and no explosion.</p> <p>要求电池外观无明显损伤, 不膨胀、不漏液、不泄压、不破裂、不起火、不爆炸。</p>
<p>High temperature storage 高温存储</p>	<p>After standard charging, the battery is stored for 2h, and have thickness measured. Under the condition of <math>70^{\circ}\text{C}\pm 2^{\circ}\text{C}</math>, the battery is stored for 16h. Then, the battery was taken out to be stored for 2h. Battery thickness is measured. Finally, the battery is charge and discharge at 0.2c current for 1 time. Recording discharge time.</p> <p>电池标准充电结束后, 开路搁置 2h, 测量厚度; 在 <math>70^{\circ}\text{C}\pm 2^{\circ}\text{C}</math> 的条件下开路搁置 16h。实验结束后, 取出电池, 开路搁置 2h, 测量厚度。然后以 0.2C 电流进行一次充放电, 记录放电时间。</p>	<p>Swelling rate <math>\leq 8\%</math>, the discharge time of recovered capacity <math>&gt; 4.75\text{h}</math>. No obvious difference on battery surface before and after test.</p> <p>电池厚度变化率 <math>\leq 8\%</math>, 恢复容量放电时间 <math>&gt; 4.75\text{h}</math>, 电池外观相比实验前无明显差异</p>
<p>Temperature cycle 温度循环</p>	<p>The standardly charged battery was shelved at <math>75^{\circ}\text{C}\pm 2^{\circ}\text{C}</math> for 6h. Then, after temperature was reduced to <math>-40^{\circ}\text{C}\pm 2^{\circ}\text{C}</math> within 30min, it is stored for 6h. This was a cycle. After 10 cycles, the battery was shelved for 1h at <math>25^{\circ}\text{C}\pm 2^{\circ}\text{C}</math>. 电池按标准充电结束后, 放入冷热冲击箱中, 电池在 <math>75^{\circ}\text{C}\pm 2^{\circ}\text{C}</math> 中搁置 6h, 然后在 30min 内将温度降至 <math>-40^{\circ}\text{C}\pm 2^{\circ}\text{C}</math> 并恒温 6h, 如此为 1 个循环, 共循环 10 次, 试验结束后在 <math>25^{\circ}\text{C}\pm 2^{\circ}\text{C}</math> 环境温度下将电池搁置 1h 进行检测</p>	<p>Battery should not leak, vent, crack, catch fire, or explode.</p> <p>要求电池应不泄露, 不泄气, 不破裂、不起火, 不爆炸。</p>
<p>Salt spray test 盐雾试验</p>	<p>The battery terminals were placed in the salt spray test box with <math>35^{\circ}\text{C}\pm 2^{\circ}\text{C}</math>, humidity <math>\geq 85\%</math> and PH value within 6.5 ~ 7.2. Its surface was sprayed with mist produced by <math>5\% \pm 1\%</math> NaCl solution for 48 hours. Checking battery surface.</p> <p>将电池端子放入 <math>35^{\circ}\text{C}\pm 2^{\circ}\text{C}</math>、湿度 <math>\geq 85\%</math>、PH 值在 6.5~7.2 范围内的盐雾试验箱中, 用 <math>5\% \pm 1\%</math> 的 NaCl 溶液盐水喷雾, 持续 48h, 检查镀层表面。</p>	<p>Surface should be free from rust, peeling and other undesirable phenomena</p> <p>要求镀层无锈蚀、剥落等不良现象。</p>
<p>Vibration test 振动测试</p>	<p>After the battery is fully charged according to the standard charging mode, the voltage and internal resistance of the battery are measured. The battery was fixed on the vibration table for vibration test within 1h. The battery was subjected to vibration with frequency of 10-60hz, amplitude of 1.6mm and frequency sweep rate of 1oct/min. The frequency was swept for 30min in the directions of X, Y and Z. Measuring voltage, internal resistance and residual capacity of the battery after the frequency sweep.</p> <p>电池按照标准充电模式充满电后, 测量电池的电压、内阻; 1h 内将</p>	<p>No obvious damage on the surface, no swelling, no leakage, no venting, no fire, no explosion. Internal resistance change be <math>\leq 10\text{ m}\Omega</math>. Voltage change be <math>\leq 0.1\text{ V}</math>.</p> <p>电池外观无明显损伤, 不膨胀、不漏液, 不泄压, 不起火, 不</p>

	<p>电池固定在振动台上，进行振动试验，电池经受频率为 10~60Hz，振幅为 1.6mm，扫频速率为 1oct/min 的扫频振动，在 X、Y、Z 三个方向上分别扫频 30min；扫频结束后，测量电池的电压、内阻、剩余容量。</p>	<p>爆炸；电池内阻变化不超过 10 mΩ，电压变化不超过 0.1V</p>
Drop 自由 跌落	<p>Battery is charged according to the standard model and have battery internal resistance and voltage measured. Within 1 h, drop test should begins. The battery is drop form 1200 mm to marble or steel plate. Each side of battery should be dropped 2 times. Then it is stored after 2 h and have test voltage and internal resistance measured. Finally, it is discharged at 0.2 C5 to cutoff voltage</p> <p>电池标准充电后，测试电池的内阻及电压，1h 内开始自由跌落试验，电池从 1200mm 高处自由跌落至大理石地板或者钢板上，6 个面各着地 2 次，跌落完成电池搁置 2h 后，测试电压、内阻、将电池以 0.2C 电流放电至终止电压。</p>	<p>No obvious damage on the surface, no crack, no swelling, no leakage, no venting, no fire, no explosion. Internal resistance change be <math>\leq 10</math> mΩ. Voltage change be <math>\leq 0.1</math> V. Discharge time <math>\geq 4</math>h.</p> <p>要求电池外观无明显破损、开裂，不膨胀、不漏液、不泄压、不起火、不爆炸；电池内阻变化不超过 10mΩ，电压变化不超过 0.1V，放电时间 <math>\geq 4</math>h</p>
Barrel 翻 滚跌落	<p>After standard charging, battery is put aside for 1h and have internal resistance and voltage measured. The height of drop is 1 m, speed is 5 RPM, and drop times is 50. After test is completed, internal resistance and voltage of the battery are measured. It is required that battery's output is normal and can be charged and discharged. Then barrel test continues. Drop times be no less than 200 times.</p> <p>电池标准充电结束后，搁置 1h，测量电池的内阻、电压；跌落高度为 1 米，转速为 5 转/分钟，跌落次数为 50 次。试验完成后，再测量电池组的内阻、电压。要求电池输出正常,能够充放电，然后继续翻滚跌落试验，跌落次数不小于 200 次。</p>	<p>After the test, the battery function is normal, and the battery structure does not detached.</p> <p>要求试验完成后电池功能正常，不出现电池结构件脱离现象</p>

## 6、Safety protection performance 安全保护性能

Overcharge protection performance 过充电保护性能	<p>After standard charging the battery shall be continuously loaded with a constant current and constant voltage source for 7h. The constant current and constant voltage source voltage shall be set as twice the nominal voltage and the current as the external current of 2C5A 电池标准充电结束后，用恒流恒压源持续给电池加载 7h，恒流恒压源电压设定为 2 倍的标称电压，电流设定为 2 C5A 的外接电流</p>	<p>The battery shall not explode, fire, smoke or leak until the end of the experiment.</p> <p>直至实验结束的整个过程，电池应不爆炸,不起火,不冒烟或漏液.</p>
Over discharge protection 过放电保护性能	<p>Battery is discharges at 0.2 C to cut-off voltage under 23 °C <math>\pm</math> 2 °C, then it is connected with 30 Ω load to discharge for 7 h</p> <p>电池在环境温度 23°C<math>\pm</math>2°C 的条件下，以 0.2 C5A 放电至终止电压后，外接 30Ω 负载放电 7h</p>	<p>The battery should not explode, catch fire, smoke or leak.</p> <p>电池应不爆炸,不起火,不冒烟或漏液.</p>

<p>Short circuit protection 短路保护</p>	<p>After fully charging, the battery is short circuited through a 0.1Ω resistor for 1 h, then is charged at 1C for 5S. Checking battery appearance. 电池完全充电后, 将正负极用 0.1Ω电阻器短路 1h, 将正负极断开后, 以 1C 电流瞬时充电 5S, 目测电池外观</p>	<p>The battery should not explode, catch fire, smoke or leak. The battery voltage should not be lower than 3.6v 电池应不爆炸, 不起火, 不冒烟或漏液. 电池电压应不低于 3.6V</p>
<p>PTC protection verification PTC 保护验证</p>	<p>Short connected MOS tube of battery with PTC. After fully charging, battery is put in the explosion-proof box and connected with electronic load to be discharged at constant discharge current of 8A. Checking current change of electronic load, and recording the time from the beginning of discharge to the small current (&lt;1A). After current changes or the current does not change but the discharge time reaches 60s, the test ends. 将带 PTC 电池的 MOS 管短接; 将电池满充后, 置于防爆箱中, 连上电子负载, 设置 8A 的恒流放电电流, 对电池进行放电, 观察电子负载的电流值变化, 记录从开始放电到电流从 8A 变化到较小电流 (&lt;1A) 时的时间; 电流变化后或者电流未变化但是放电时间达到 60s 则实验结束。</p>	<p>The time from the start of discharge to rapid current change should be less than 60s. 要求从开始放电到电流突变的时间应小于 60s。</p>

## 7、Cell safety performance 电芯安全性能

The following tests shall be carried out in devices with mandatory exhaust conditions and explosion protection measures. Before the test, all batteries should be charged in the standard charging mode. The following experiments should be completed within 24h, and the following tests should be conducted after removing the external protective circuit of the battery.

下述试验应在有强制排风条件及防爆措施的装置内进行, 在试验前所有的电芯按照要求充放电后, 再进行以下试验。

测试项目	测试方法	检验标准
<p>Impact 重物冲击</p>	<p>After standard charged, the battery is placed on a flat surface. A φ15.8mm diameter bar is to be placed across the center of the sample. A 9.1kg weight is to be dropped from a height of 610±25mm onto the sample. Observed for 6h after testing. 电池放置于一平面上, 并将一个直径15.8mm±0.2mm的钢柱置于电池中心, 钢柱的纵轴平行于平面, 让质量9.1Kg±0.1Kg的重物从610mm±25mm高度自由落到电池中心上方的钢柱上, 测试完毕观察6h。</p>	<p>Battery should be no explosion or fire 电池不起火, 不爆炸</p>
<p>Thermal Shock 热冲击</p>	<p>After the standard charge of the cell is finished, it is put into an oven for heating. The temperature of the oven rises to 130±2°C at the rate of (5±2°C) /min, and keep for 30min. 电芯标准充电结束后, 放于一个烘箱中加热, 烘箱的温度以 (5±2°C) /min 的速率上升到 130±2°C, 保持 30min,</p>	<p>The battery should not explode or fire. 电池不起火, 不爆炸</p>
<p>Thermal shock (low temperature)</p>	<p>Under 5°C, after being fully charged with the maximum current allowed by the supplier, the battery is placed in an oven for heating. The oven temperature rises to 130±2°C at a rate of (5±2°C) /min and remains there</p>	<p>The battery should not catch fire or explode. 电池不起火, 不爆炸</p>

<p>charging)热冲击(低温充电)</p>	<p>for 30min.                  电池置于 5°C 环境下, 采用该温度下供应商允许的最大电流充满电后, 放于一个烘箱中加热, 烘箱的温度以 (5±2°C) /min 的速率上升到 130±2°C, 保持 30min。</p>	
<p>Over charging (3C/4.8V)                  过充电 (3C/4.8V)</p>	<p>Placing the cell connected with thermocouple in the fume hood, connecting the positive and negative electrodes to a constant current and constant voltage power supply, adjusting the current to be 3C<sub>5</sub> and voltage to be 4.8V, and then charging the battery to 3C<sub>5</sub> until battery voltage reaches 4.8V and current be close to 0A. Monitoring battery temperature change during the test, and stop the experiment when the battery temperature drops to be about 10°C lower than the peak value. 将接有热电偶的电芯置于通风橱中, 连接正负极于一恒流恒压电源, 调节电流至 3 C<sub>5</sub>、电压为 4.8V, 然后对电芯以 3 C<sub>5</sub> 充电, 直到电池电压为 4.8V, 电流将到接近 0A。试验过程中监视电池温度变化, 当电池温度下降到比峰值低约 10°C, 停止实验</p>	<p>No explosion, no fire, the maximum surface temperature of the battery ≤150°C                  要求电芯不爆炸、不起火, 电池的表面最高温度 ≤150°C</p>
<p>High temperature and short circuit                  高温短路</p>	<p>After charging standard, the battery's positive and negative connect with thermocouple or wire with resistance ≤ 80 + 20 mΩ. Under 55 °C + 5 °C, battery is discharged until battery fire or explode or when the surface temperature of the battery back to be &lt;10 °C of environment temperature.                  电芯标准充电后, 将接有热电偶的电芯用电阻不大于 80±20 mΩ 的导线短接电池正负极, 该实验在 55°C ± 5°C 环境下进行, 放电直至电池起火或爆炸或当电池的表面温度恢复至环境温度 10°C 以内时, 试验结束</p>	<p>Battery does not fire or explode. Surface temperature does not exceed 150°C                  电池不起火、不爆炸, 外部表面温度不超过 150°C</p>
<p>Forced discharge                  强制放电</p>	<p>Under 23 °C ± 2 °C, cell connected with thermocouple was discharged to 3.0 V at a current of 0.2 C<sub>5</sub>A, and then reversely charged at 1 C<sub>5</sub> A for 90 min. 电芯放在 23°C ± 2°C 的条件下, 将接有热电偶的电芯以 0.2C<sub>5</sub>A 电流放电至 3.0V, 再以 1C<sub>5</sub>A 电流对电池反向充电, 持续 90min。</p>	<p>No explosion or fire. Surface temp should not exceed 150 °C. 电池应不爆炸、不起火, 外部温度不得高于 150°C</p>

## 8、List of main materials of battery 电池主要物料清单

物料名称	物料规格	材料	数量	单位
上盖	上盖\13116-A0\ABS+PC\VO	ABS+PC防火	1	PCS
下盖	下盖\13116-A0\ABS+PC\VO	ABS+PC防火	1	PCS
电芯	电芯\386267AS\2500\焊顶\4.40V	铝壳	1	pcs
喷码	电芯喷码			
保护板 \13116\A0	IC:R5487L303KM-TR (理光) 主选 / MM3280EAUUYRE (美之美) 备选/ MOS:SM9998DSQG/DFN2*3 (大中) 主选 PED2311DN (芯电元) 备选/ CJCD2003/DFN 2*3 (长电) 备选 NTC:CN0402R103B3435FT/0402 10K 1% B=3435 (仙桥); ID:82K 5% PTC:LP- NSML500/1206 维安 主选 KT6-5000SMDIII-G 科特 备选 五金: 2.4*2*0.3mm 3pcs 镀金: 0.2μm	FR-4	1	pcs
正极镍片	卷料7mm (裁切0.1*2.5*7+2*10)	纯镍	0.02	g
负极镍片	卷料7mm (裁切0.1*2.5*7+2*10)	纯镍	0.02	g
AB胶	A胶	/	0.15	g
	B胶	/	0.15	g
青稞纸	10*2.5*0.15mm	青稞纸	1	pcs
商标	U303AF商标	54#合成 纸覆哑膜	1	pcs
防水贴	5.6*2.8*0.15mm	/	1	pcs
CPE袋	白色CPE胶袋\75MM\95MM+30MM\无品牌LOGO黑色07循环	CPE磨砂袋	1	pcs
注塑胶料	1532	1532	1.5	g
封箱标	绿色封箱标	合成纸	2/400	pcs
箱唛	102*76mm	铜版纸	5/400	pcs
称重标	57*43mm	铜版纸	5/400	pcs
条码标	70*40mm	铜版纸	5/400	pcs
纸箱	53032外箱\425MM\370MM\220MM\K=K	K=K	1/400	pcs
	53032内箱\357MM\205MM\98MM\K3K	K=K	4/400	pcs
	53032四刀卡\86MM\352MM\3MM\K3K	A=B	76/400	pcs
	53032十九刀卡\86MM\197MM\3MM\K3K	K3K	16/400	pcs
	平卡\352MM\200MM\5MM\A=B	A=B	4/400	pcs

### 8.1 List of main materials of cell 电芯主要物料清单

组成部分	材料	样品供应商	量产供应商	量产供应商主选	重量 (g)
电芯型号	386267Ar	维科	维科	维科	约40.0g
壳体	铝壳	东达	东达、鑫奇睿	东达	约6.0g
电芯正极材料	钴酸锂	中信国安	中信国安、巴莫、当升	中信国安	约15.0g
电芯负极材料	石墨	紫宸	紫宸、杉杉、正拓	紫宸	约8.1g
电解液	溶剂+锂盐	新宙邦	天赐、新宙邦	新宙邦	4.25g~7.5g
隔膜	基膜9um+3um陶瓷	聚成	纽米/聚成 (基膜厂家纽米, 涂层 厂家纽米/聚成)	纽米	/

## 8.2 Material list of PCM 保护板关键物料清单

位号	物料名称	规格型号	性能参数	数量	品牌	ROHS报告编号	检验时间
U1	Protection IC	R5487L303KM-TR (F) (主选)	过充检测电压:4.475±0.02V 过放检测电压:2.5±0.035V 过流检测电压:0.13±0.010V 短路检测电压:0.3±0.075V	1	理光	CE/2018/A0499A	2018/10/17
		MM3280EAUZYRE (备选)	过充检测电压:4.475±0.020V 过放检测电压:2.50±0.035V 过流检测电压:0.2±0.01V 短路检测电压:0.3±0.075V	1	美之美	CE/2018/B3094 JP/2019/060698 JP/2018/080420 CE/2018/A0682 CE/2018/A1367 JP/2018/100350	2018/11/22 2019/6/24 2018/9/5 2018/10/16 2018/10/17 2018/10/18
Q1	MOSFET	SM9998DSQG (主选)	VDS:20V, VGS:±12V, ID:9.7A, TJ:-55-150(C)	1	大中	SHAEC1900926402 CE/2019/32729 CE/2019/32732 CE/2018/C2910 SHAEC1916535620 SHAEC1910748915 A01 SHAEC1819010701	2019/2/23 2019/3/19 2019/3/19 2018/12/21 2019/8/5 2019/6/3 2018/9/14
		CJCD2003 (备选)	VDS:18V, VGS:±12V, ID:10A, TJ:-55-150(C)	1	长电	SHAEC1806718303	2018/4/16
		PED2311DN DFN2*3 (备选)	VDS:20V, VGS:±12V, ID:12A, TJ:-55-150(C)	1	芯电元	SHAEC1806669303	2018/4/20
R1	电阻	330Ω/0402/±5%		1	国巨	SHAEC1826952421	2018/12/14
R2	电阻	1KΩ/0402/±5%		1	国巨	SHAEC1826952421	2018/12/14
C1-C4	电容	0.01uF/0402/-20%~+80% /16V		4	国巨	KA/2019/10409	2019/01/19
RT	NTC	0402/10K±1% B=3435K		1	仙桥	CANEC1806152201	2018/4/16
R3	ID	82KΩ/±1%/0402		1	国巨	SHAEC1826952421	2018/12/14
F1	PTC	LP-NSML500/1206		1	维安	SHAEC1825600901 SHAEC1917835804 SHAEC1917835808 SHAEC1917835805 SHAEC1917835802 SHAEC1917835809	2018/11/30 2019/8/19 2019/8/19 2019/8/19 2019/8/19 2019/8/19
		KT6-5000SMDIII-G		1	科特	A2180200661101001E A2180092629301001Ea A2180214853101002 A2190033065101003E A2180110014101001E A2190073843102008	2018/10/26 2018/12/10 2018/11/13 2019/2/27 2019/1/24 2019/4/10
B+ B-	镍片	3*2.5*0.3mm, 纯镍片		2	富佳达	CANML1822096401	2018/11/5
P+/P- /ID/T	贴片五金	3.15*1.60*0.40mm		4	宏利	A2190112340101001	2019/5/18
PCB	PCB	XA121924-A,53.6*3.1*0.7mm,FR4,4层,喷锡,黑色,白字,1OZ		1	吉瑞达	CANEC1901112519 SHAEC1918052202 CE/2018/94796 SHAEC1908767211 SHAEC1900829916 EM190604034CC001X001	2019/1/24 2019/9/4 2018/10/5 2019/5/8 2019/1/19 2019/6/17
/	UV胶	UV胶 8817-2 蓝色 250g/瓶		0.3g	高佳宇	C190215009001	2019/2/18



## 9、PCM parameters 保护板参数规格

序号	项 目	参 数		
		最小值	典型值	最大值
1	过充电保护电压 (V)	4.455	4.475	4.495
2	过充电恢复电压 (V)	4.225	4.275	4.325
3	过放电保护电压 (V)	2.465	2.500	2.535
4	过放电恢复电压 (V)	2.827	2.9	2.973
5	过电流保护 (A)	6.0	-	12.0
6	过电流保护电压 (mV)	0.12	0.130	0.140
7	过充电延时时间 (ms)	700	1000	1300
8	过放电延时时间 (ms)	14	20	26
9	过电流延时时间 (1) (ms)	8	12	16
10	NTC 电阻(K $\Omega$ ) $\pm$ 5% (25 $^{\circ}$ C)	9.9	10	10.1
11	工作时电路内部消耗 ( $\mu$ A)	/	/	6.0
13	内 阻 (m $\Omega$ )	/	/	60

## 10、 2D drawing 2D 图纸(TINNO 原图)及电芯图纸、原理图、标贴、爆炸图、包装说明图

### 10.1 电芯结构图（要求按照模板提供完整信息）

要求按照模板提供电芯半电和满充的厚度，各细节的尺寸标注要完善

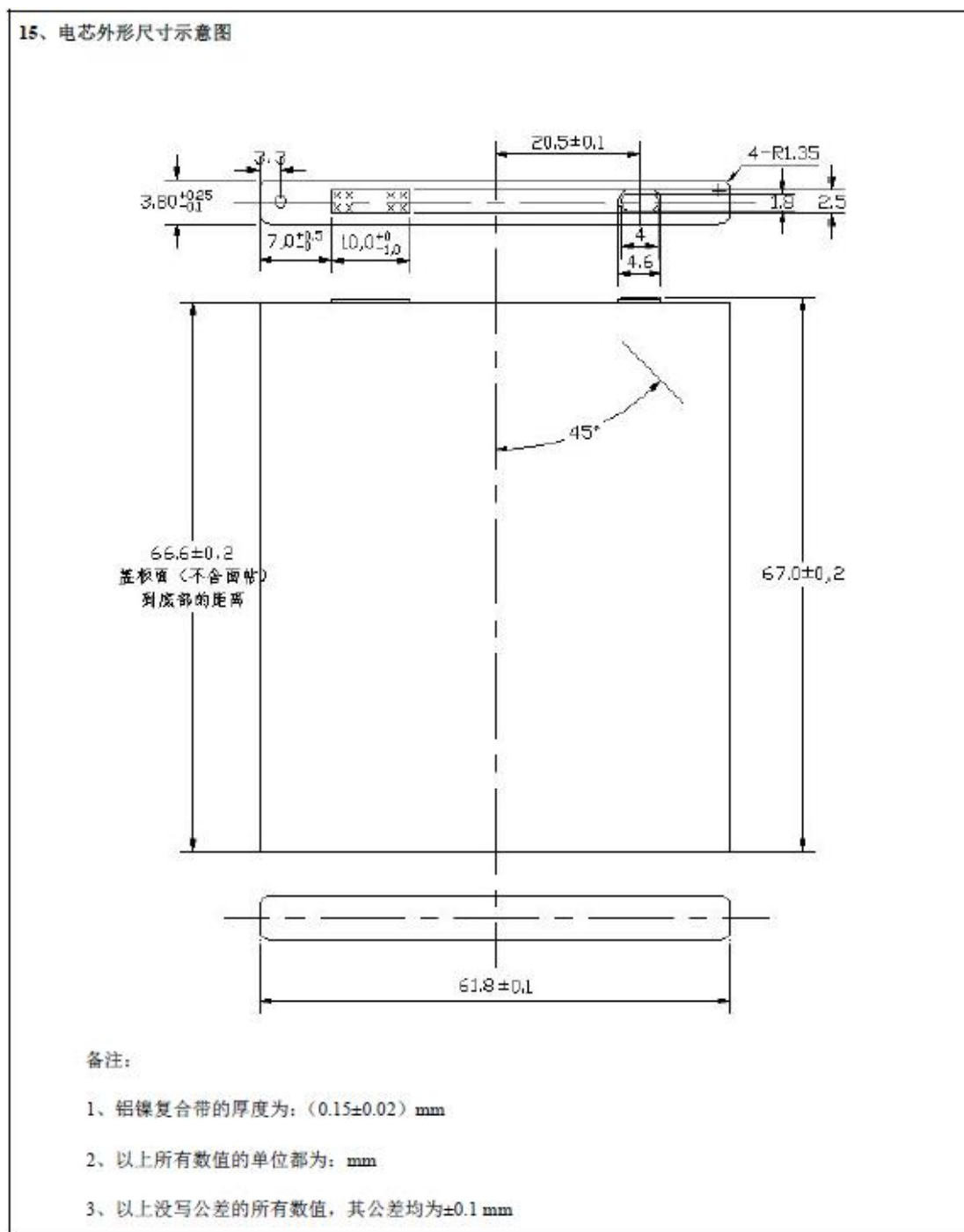

## 10. 2PCM schematic diagram, layout, physical picture 保护板原理图、layout、实物图片

### PCM schematic diagram 原理图

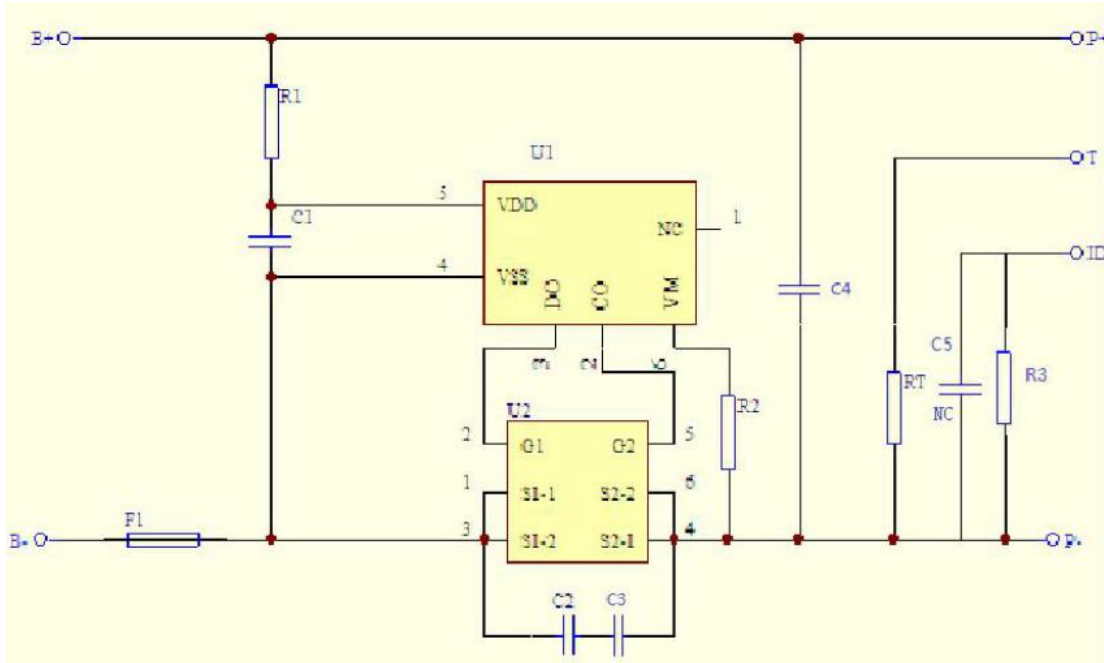

### physical picture 实物正反面照片



### Layout

#### ■ TOP 丝印层

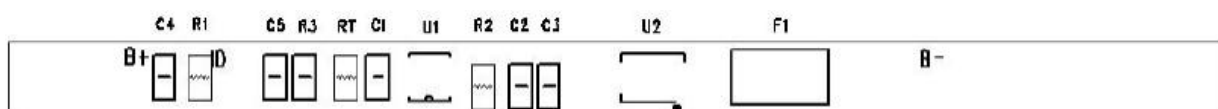

## ■ TOP MASK 层



## ■ TOP 层线路



## ■ 中间 1 层线路



## ■ 中间 2 层线路



## ■ BOTTOM 丝印层



## ■ BOTTOM MASK 层

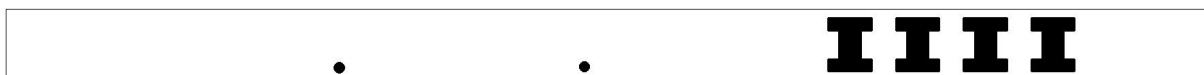

## ■ BOTTOM 层线路

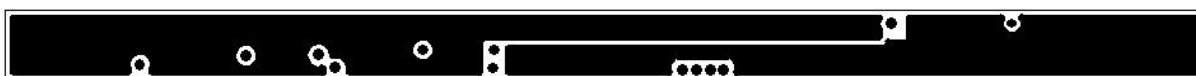

## 10.3 Label 标贴

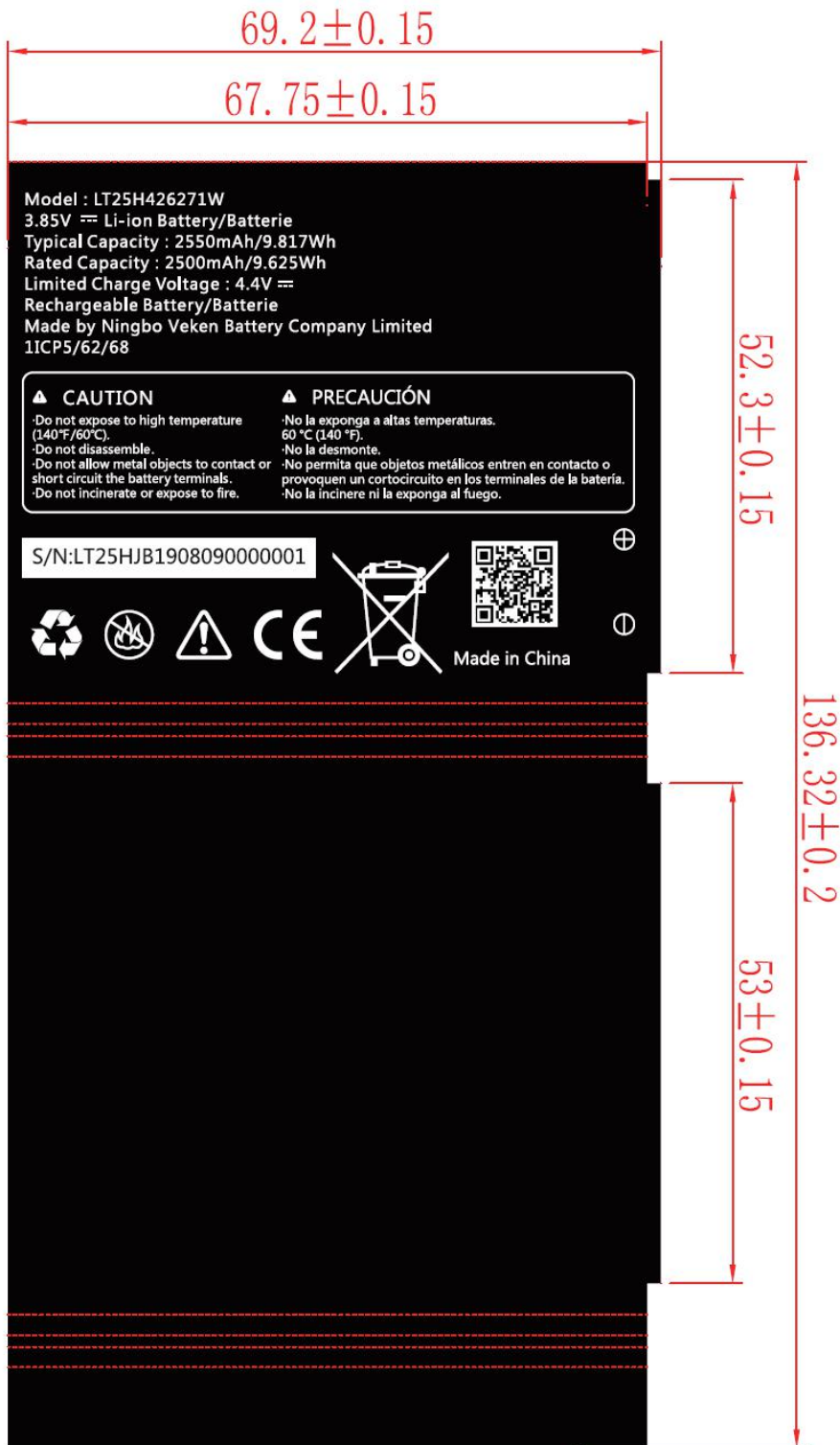

## 10.4 2D Battery drawing 电池 2D 图纸

Project code 工程代码	13116																																										
<p><b>技术要求:</b></p> <ol style="list-style-type: none"> <li>1. 出货电压: 3.93~4.0V, 成品内阻 <math>\leq 110\text{m}\Omega</math>, NTC: 10K <math>\pm 1\%</math>, ID: 82K 1%, 过流值: 6-12A;</li> <li>2. 外观要求: 商标字体清晰无脏污; 外壳无缩水刮伤拔锋等, 五金弹片表面不许有划伤, 氧化, 锈迹, 脏污, 回弹不良等;</li> <li>3. 标有*号的尺寸为重点控制尺寸;</li> <li>4. 材质须符合欧盟ROHS、REACH、HF要求。</li> </ol> <p><b>Technical requirements:</b></p> <ol style="list-style-type: none"> <li>1. Shipment voltage: 3.93~4.0V, Battery internal resistance: <math>\leq 110\text{ m}\Omega</math>, NTC: 10k 1%, ID:82k 1% Over discharge current protection: 6-12A;</li> <li>2. Appearance requirements: trademark font is clear and free from dirt; No shrinkage scratch on the shell, no scratch on the surface of metal shrapnel, Oxidation, rust, smudging, poor resilience, etc.</li> <li>3. The size marked with * is the key control size;</li> <li>4. Materials shall meet the requirements of eu ROHS, REACH and HF.</li> </ol>																																											
<table border="1" style="width: 100%; border-collapse: collapse;"> <tr> <th>Conventional tolerance 常规公差</th> <th>Drawing name 名称</th> <th>Battery drawing 成品电池图</th> <th colspan="2">Dongguan yongwei technology co., LTD. 东莞市永纬科技有限公司</th> </tr> <tr> <td>0~10</td> <td>Project name 项目名称</td> <td>U303AP-T</td> <td colspan="2"></td> </tr> <tr> <td>10~50</td> <td>Document number 文件号</td> <td>YW-QS-DWG-FZ1495-006</td> <td colspan="2"></td> </tr> <tr> <td>50~100</td> <td>Version 版本号</td> <td>A0</td> <td colspan="2"></td> </tr> <tr> <td>More than 100%</td> <td>Unit 单位</td> <td>mm</td> <td colspan="2"></td> </tr> <tr> <td></td> <td>Proportion 比例</td> <td>1:1</td> <td colspan="2"></td> </tr> </table>		Conventional tolerance 常规公差	Drawing name 名称	Battery drawing 成品电池图	Dongguan yongwei technology co., LTD. 东莞市永纬科技有限公司		0~10	Project name 项目名称	U303AP-T			10~50	Document number 文件号	YW-QS-DWG-FZ1495-006			50~100	Version 版本号	A0			More than 100%	Unit 单位	mm				Proportion 比例	1:1			<table border="1" style="width: 100%; border-collapse: collapse;"> <tr> <th>Version 版本</th> <th>Modification content 修改内容</th> <th>Modification date 修改日期</th> </tr> <tr> <td> </td> <td> </td> <td> </td> </tr> <tr> <td> </td> <td> </td> <td> </td> </tr> </table>			Version 版本	Modification content 修改内容	Modification date 修改日期						
Conventional tolerance 常规公差	Drawing name 名称	Battery drawing 成品电池图	Dongguan yongwei technology co., LTD. 东莞市永纬科技有限公司																																								
0~10	Project name 项目名称	U303AP-T																																									
10~50	Document number 文件号	YW-QS-DWG-FZ1495-006																																									
50~100	Version 版本号	A0																																									
More than 100%	Unit 单位	mm																																									
	Proportion 比例	1:1																																									
Version 版本	Modification content 修改内容	Modification date 修改日期																																									

## 10.5 电池组装图

工程代码

13116

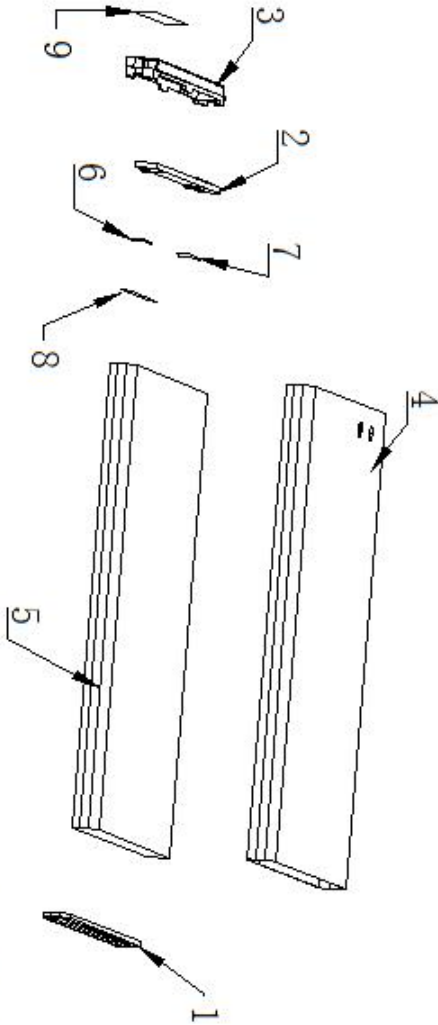

名称	规格/材质	数量
9 防水贴	5.6*2.8*0.15mm	1
8 背标纸	10*2.5*0.15mm	1
7 正极铜片	0.1*2.5*7+2*10	1
6 负极铜片	0.1*2.5*7+2*10	1
5 电芯	386267Ae / 2500mAh	1
4 商标	U303AF商标	1
3 上盖	13116上盖	1
2 保护板	13116保护板	1
1 下盖	13116下盖	1

序号	部件名称	规格/材质	数量
总装图			
U303AF-T			
东莞市甬维科技有限公司			
项目名称	YW-QS-DWG-FZ***-007	视角	
文件号	WO	绘图	
版本号		审核	
单位	mm	日期	
比例	1:1	批准	

版本	修改内容	修改日期

## 10.6 包装说明图

工程代码	13116
------	-------

版本	修改内容	修改日期

**1. 成品电池：**将成品电池装入胶袋，电池五金朝下，不封口。电池的二维码与07字样不在同一面。

**2. 将成品电池装入胶袋，**电池五金朝下，不封口。电池的二维码与07字样不在同一面。

**3. 装好胶袋的电池五金朝上装入内箱格子，**每个内盒装100PCS，超出电池部分胶袋需折叠；每箱电池五金方向需保持一致

**4. 外箱上下两面贴封箱标，**透明胶工字型封箱

天玑系统箱唛  
箱唛与包装箱边缘 10-20mm

称重标

短边左上角 箱唛与包装箱边缘 10-20mm

天玑系统箱唛

称重标

4. 将装好电池的内箱，“一”字封箱，装入外箱中，每个外箱装400PCS电池（每层2小箱，共2层），

名称	包装图		东莞市甬维科技有限公司	
项目名称	I303AF-T			
文件号	YW-QS-DWG-FZ1495-008			
版本号	A0		绘图	
单位	mm		审核	
比例	1:1		批准	



## 11. 电池标识:

实物图片:

