

Item #1007 615 884

Model #725.1960.000

HAMPTON BAY[®]

USE AND CARE GUIDE

WINDSWEPT SWIVEL CHAIR

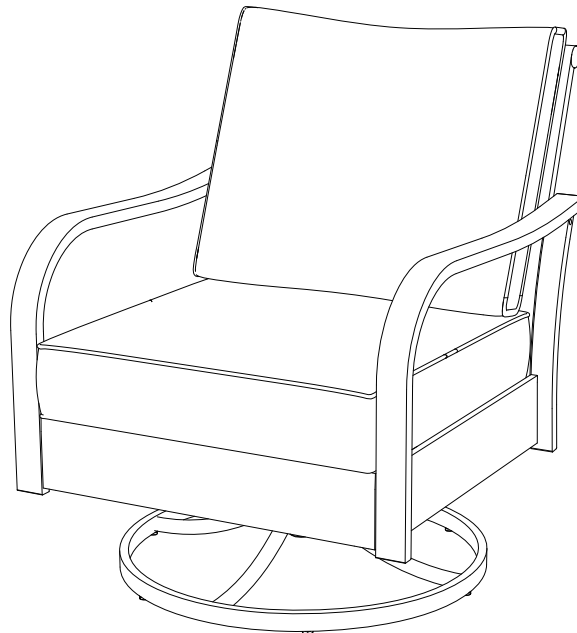

Questions, problems, missing parts? Before returning to the store,
call Hampton Bay Customer Service
8 a.m. - 7 p.m., EST, Monday – Friday, 9 a.m. – 6 p.m., EST, Saturday

1-800-841-1350

HAMPTONBAY.COM

THANK YOU

We appreciate the trust and confidence you have placed in Hampton Bay through the purchase of this chair. We strive to continually create quality products designed to enhance your home. Visit us online to see our full line of products available for your home improvement needs. Thank you for choosing Hampton Bay!

Table of Contents

Table of Contents	2	Hardware Included.	3
Important Safety Instructions	2	Package Contents	4
Warranty	2	Assembly.	5
What is covered	2	Care and Cleaning	7
What is not covered	2		
Pre-Assembly	3		
Planning Assembly.	3		

Important Safety Instructions

SAVE THESE INSTRUCTIONS

READ ALL INSTRUCTIONS BEFORE USE

To reduce the risk of injury to persons:

1. Close supervision is necessary when this furnishing is used by or near children, or disabled persons, if applicable.
2. Use this furnishing only for its intended use as described in these instructions. Do not use attachments not recommended by the manufacturer.



CAUTION: Read all of the instructions in this manual before you begin assembly. Failure to do so may result in faulty assembly and potential injury!

Warranty

3 YEAR WARRANTY

WHAT IS COVERED

We warrant the product to be free of manufacturing defects to the original purchaser for three years.

WHAT IS NOT COVERED

It remains the customer's responsibility for freight and packaging charges to and from our service center. This warranty does not cover commercial use, hardware, acts of nature, freezing, or abusive use. In addition, purchased parts are not covered under this warranty.

We reserve the right to make substitutions with similar merchandise, if the model in question is no longer in production.

Contact Customer Care at 1-800-841-1350 or visit www.hamptonbay.com.

Pre-Assembly

PLANNING ASSEMBLY

Please read this entire instruction manual prior to assembly.

Identify all parts packed in the carton against the parts list. Remove all protective materials and place the parts on a non-abrasive surface to avoid scratching.



NOTE: More than one person may be required to assemble this product.

HARDWARE INCLUDED



NOTE: Hardware not shown to actual size.

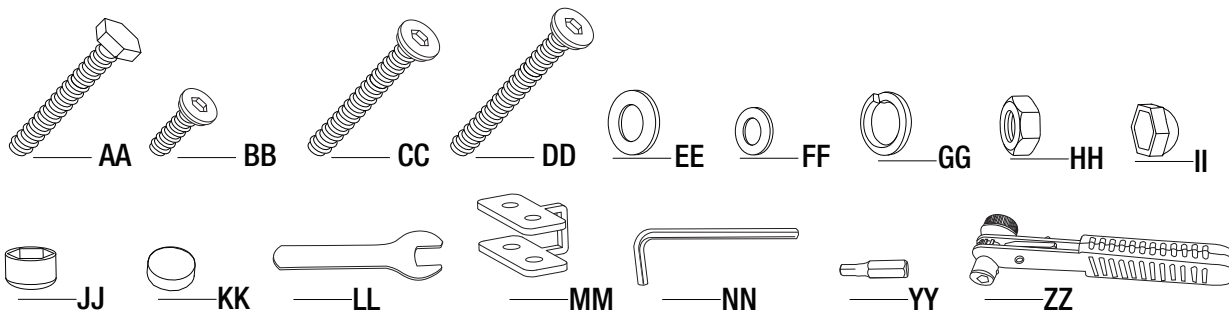

Part	Description	Quantity
AA	M8x40 bolt	4
BB	M6x20 bolt	6
CC	M6x45 bolt	2
DD	M6x55 bolt	2
EE	Washer for M8 bolt	4
FF	Washer for M6 bolt	10
GG	Spring washer	4
HH	Nut	4
II	Bolt cap for nut	8
JJ	Bolt cap for bolt	8
KK	Bolt cap for bolt M6	10
LL	Hex wrench	2
MM	Metal plate	2
NN	Allen driver	1
YY	Hex screw (6mm)	1
ZZ	Ratchet wrench	1

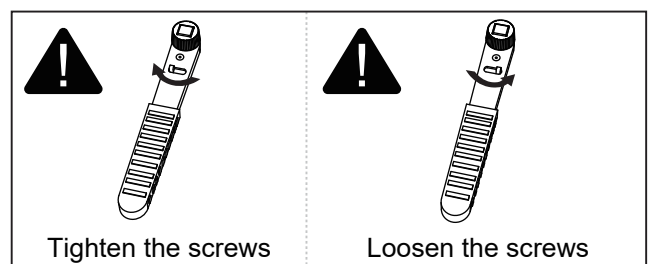
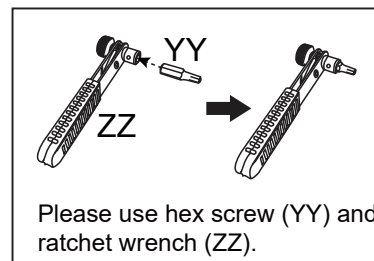

NOTE: Part YY and ZZ are additional tools, same function as part NN, but much easier to use.

Pre-Assembly

PACKAGE CONTENTS



IMPORTANT: Do not fully tighten bolts/screws until all pieces are loosely assembled.

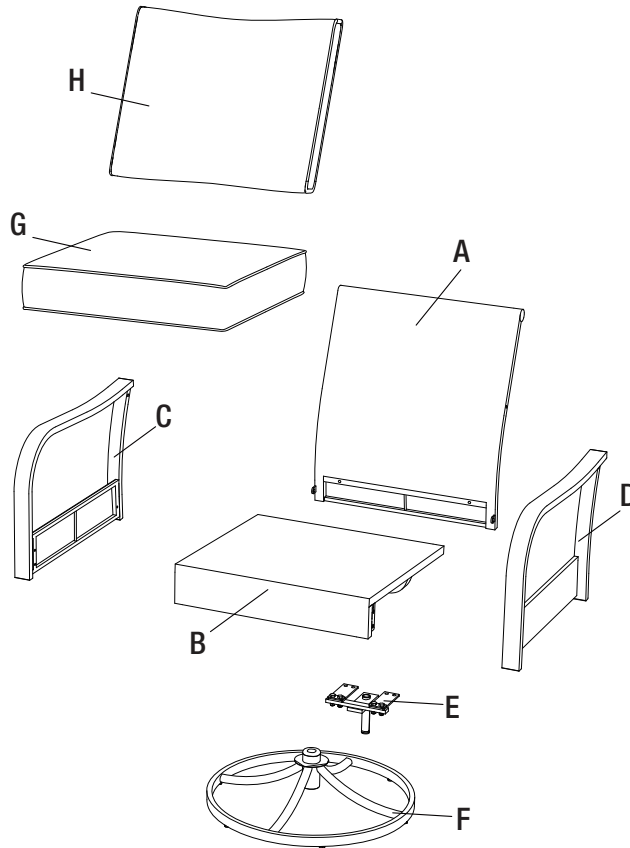

Part	Description	Quantity
A	Chair back	1
B	Chair seat	1
C	Right arm	1
D	Left arm	1
E	T-rock	1
F	Chair base	1
G	Seat cushion	1
H	Back cushion	1

Assembly

1 Attaching the chair seat to the chair back

- Attach the chair seat (B) to the chair back (A) using M6 bolts (CC) and washers (FF).



NOTE: Please ensure all the bolts are assembled correctly and use the Allen driver (NN) to tighten. Do not fully tighten bolts/screws until all pieces are loosely assembled. Add corresponding bolt caps (KK) after final assembly is finished.

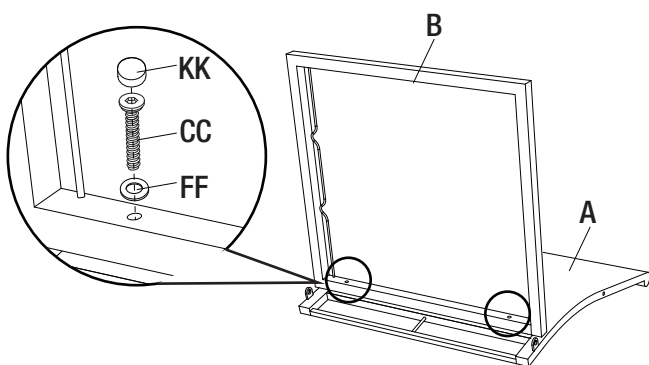

2 Attaching the right arm to the chair seat

- Attach the right arm (C) to the chair seat (B) using M6 bolts (BB) and washers (FF).



NOTE: Please ensure all the bolts are assembled correctly and use the Allen driver (NN) to tighten. Do not fully tighten bolts/screws until all pieces are loosely assembled. Add corresponding bolt caps (KK) after final assembly is finished.

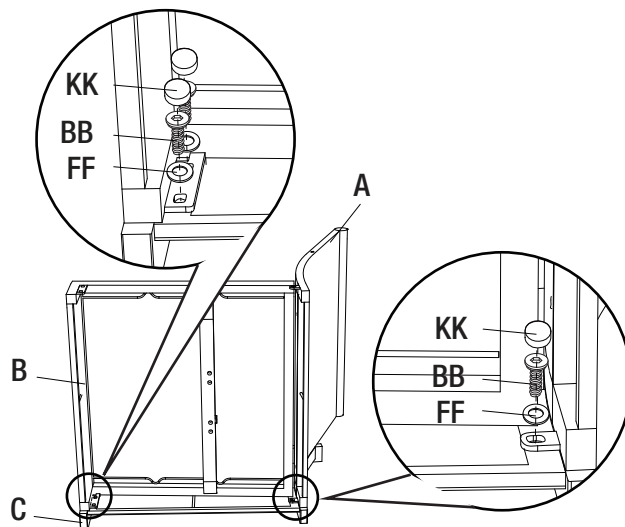

3 Attaching the left arm to the chair seat

- Attach the left arm (D) to the chair seat (B) using M6 bolts (BB) and washers (FF).

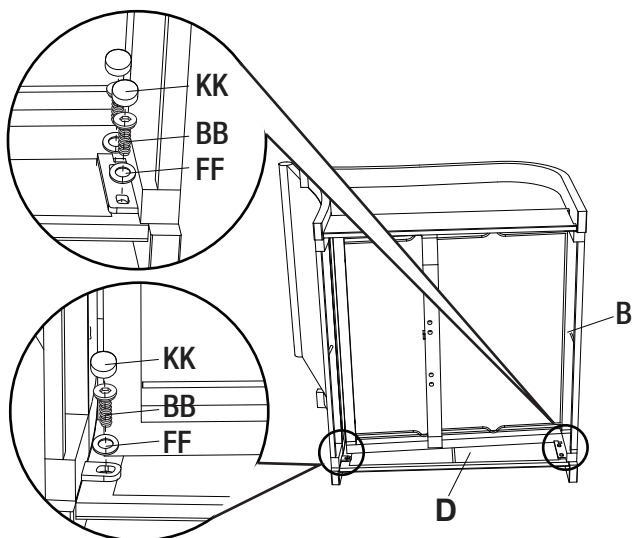

4 Attaching the chair arms to the chair back

- Attach the left arm (D) and right arm (C) to the chair back (A) using M6 bolts (DD) and washers (FF).

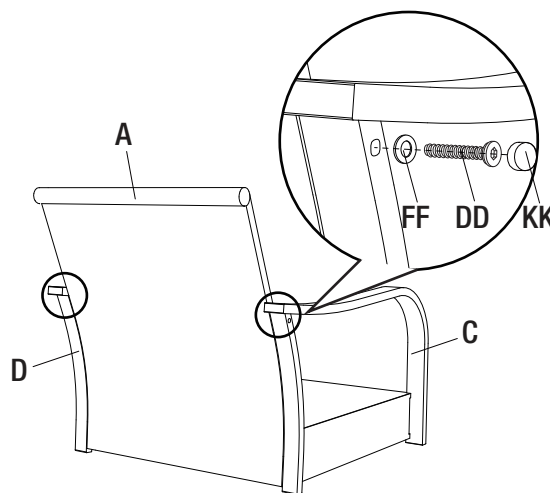

Assembly

5 Attaching the T-rock to the chair seat

- Attach the T-rock (E) to the chair seat (B) using M8 bolts (AA), metal plate (MM), washers (EE and GG), and nuts (HH).



NOTE: Please ensure all the bolts are assembled correctly and use the hex wrench (LL) and Allen driver (NN) to tighten. Do not fully tighten bolts/screws until all pieces are loosely assembled. Add the corresponding bolt caps (II, JJ) after final assembly is finished.

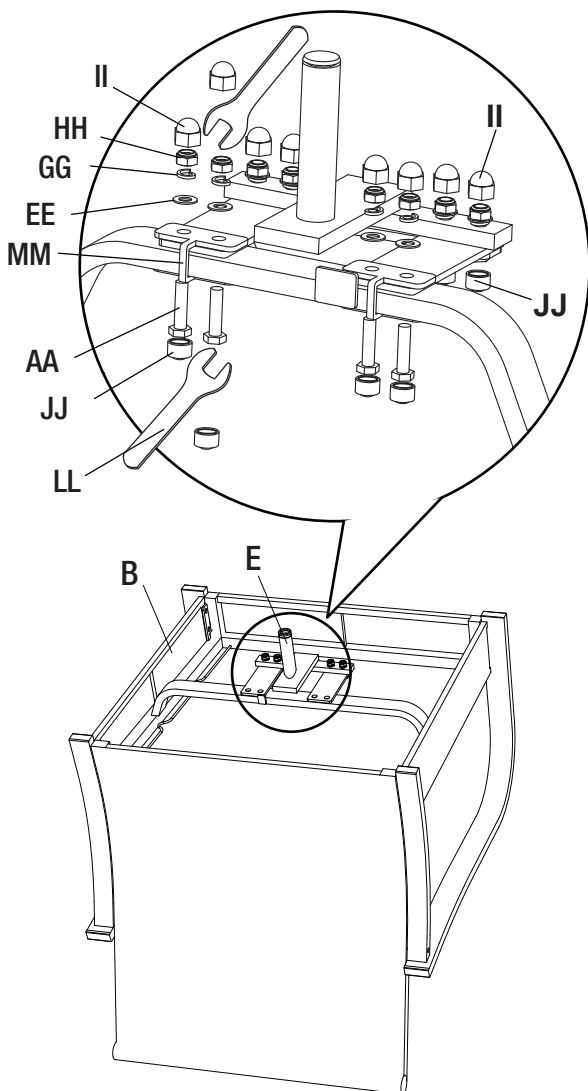

6 Inserting the chair seat into the chair base

- Insert the chair seat into the chair base (F).

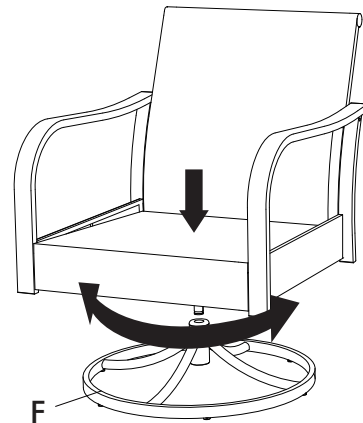

7 Adding the cushions

- Add the seat cushion (G) and back cushion (H).

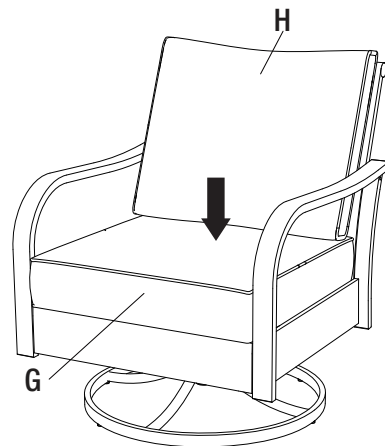

Care and Cleaning

- Do not allow water to build up in the frames. This will cause corrosion and possible freezing damage in cold climates.
- Use a mild soap and water for normal cleaning. Do not use janitorial or alcohol based cleaners. Some cleaners may be marked as natural, but some ingredients may cause discoloration or have an adverse reaction to your finish.
- Rinse with clean water and dry with a soft, absorbent cloth towel.
- Use and operation: To improve the lifespan of this furniture, cover when not in use and store in a dry place in the off season.

HAMPTON BAY®

Questions, problems, missing parts? Before returning to the store,
call Hampton Bay Customer Service
8 a.m. – 7 p.m., EST, Monday – Friday, 9 a.m. – 6 p.m., EST, Saturday

1-800-841-1350

HAMPTONBAY.COM

Retain this manual for future use.

Item #1007 615 884

Model #735.2360.000

HAMPTON BAY[®]

USE AND CARE GUIDE

WINDSWEPT SIDE TABLE

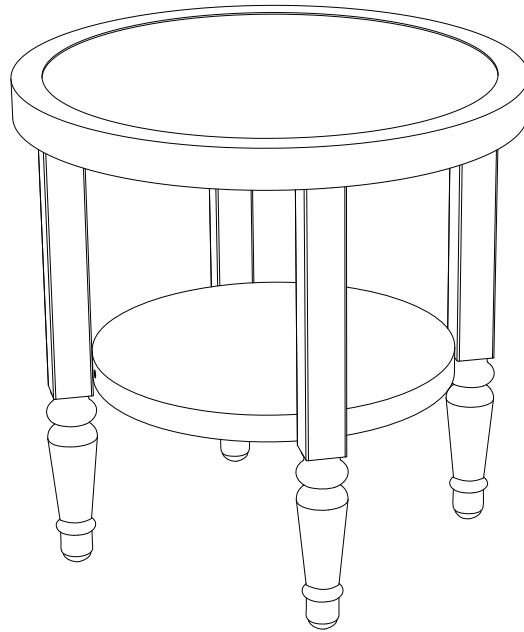

Questions, problems, missing parts? Before returning to the store,
call Hampton Bay Customer Service
8 a.m. - 7 p.m., EST, Monday – Friday, 9 a.m. – 6 p.m., EST, Saturday

1-800-841-1350

HAMPTONBAY.COM

THANK YOU

We appreciate the trust and confidence you have placed in Hampton Bay through the purchase of this table. We strive to continually create quality products designed to enhance your home. Visit us online to see our full line of products available for your home improvement needs. Thank you for choosing Hampton Bay!

Table of Contents

Table of Contents	2	Hardware Included.	3
Important Safety Instructions	2	Package Contents	4
Warranty	2	Assembly	5
What is covered	2	Care and Cleaning	6
What is not covered	2		
Pre-Assembly	3		
Planning Assembly.	3		

Important Safety Instructions

SAVE THESE INSTRUCTIONS

READ ALL INSTRUCTIONS BEFORE USE

To reduce the risk of injury to persons:

1. Close supervision is necessary when this furnishing is used by or near children, or disabled persons, if applicable.
2. Use this furnishing only for its intended use as described in these instructions. Do not use attachments not recommended by the manufacturer.

 **CAUTION:** Read all of the instructions in this manual before you begin assembly. Failure to do so may result in faulty assembly and potential injury!

Warranty

3 YEAR WARRANTY

WHAT IS COVERED

We warrant the product to be free of manufacturing defects to the original purchaser for three years.

WHAT IS NOT COVERED

It remains the customer's responsibility for freight and packaging charges to and from our service center. This warranty does not cover commercial use, hardware, acts of nature, freezing, or abusive use. In addition, purchased parts are not covered under this warranty.

We reserve the right to make substitutions with similar merchandise, if the model in question is no longer in production.

Contact Customer Care at 1-800-841-1350 or visit www.hamptonbay.com.

Pre-Assembly

PLANNING ASSEMBLY

Please read this entire instruction manual prior to assembly.

Identify all parts packed in the carton against the parts list. Remove all protective materials and place the parts on a non-abrasive surface to avoid scratching.



NOTE: More than one person may be required to assemble this product.

HARDWARE INCLUDED



NOTE: Hardware not shown to actual size.

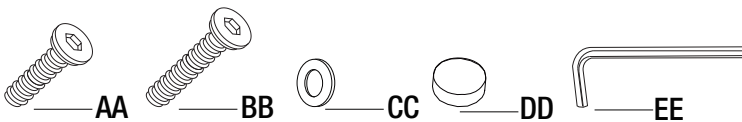

Part	Description	Quantity
AA	M6x20 Bolt	8
BB	M6x35 Bolt	4
CC	Washer	12
DD	Bolt cap	12
EE	Allen driver	1

Pre-Assembly

PACKAGE CONTENTS



IMPORTANT: Do not fully tighten bolts/screws until all pieces are loosely assembled.

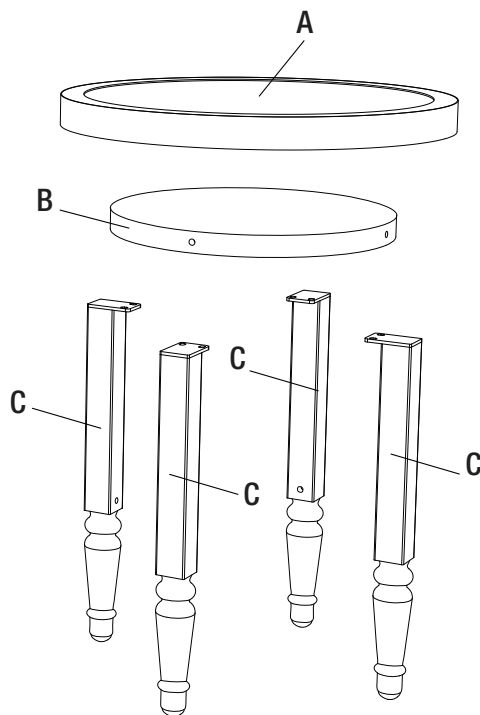

Part	Description	Quantity
A	Table top	1
B	Support plate	1
C	Table leg	4

Assembly

1 Attaching the table legs to the table top

- Attach the table legs (C) to the table top (A) using M6 bolts (AA) and washers (CC).



NOTE: Please ensure all the bolts are assembled correctly and use the Allen driver (EE) to tighten. Do not fully tighten bolts/screws until all pieces are loosely assembled. Add corresponding bolts caps (DD) after final assembly is finished.

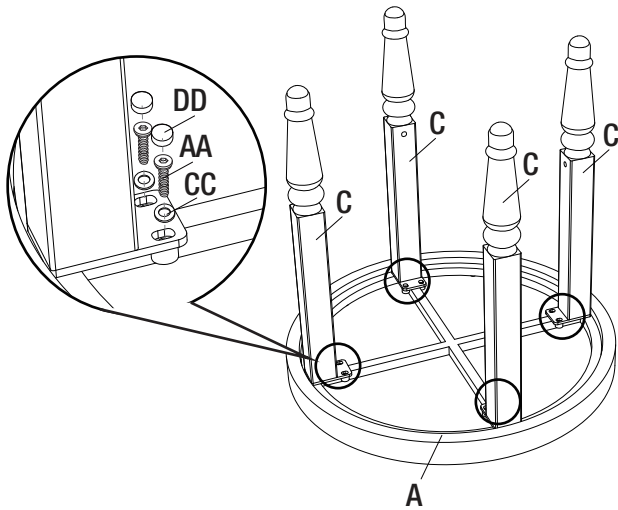

2 Attaching the support plate to the table legs

- Attach the support plate (B) to the table legs (C) using M6 bolts (BB) and washers (CC).



NOTE: Please ensure all the bolts are assembled correctly and use the Allen driver (EE) to tighten. Do not fully tighten bolts/screws until all pieces are loosely assembled. Add corresponding bolts caps (DD) after final assembly is finished.

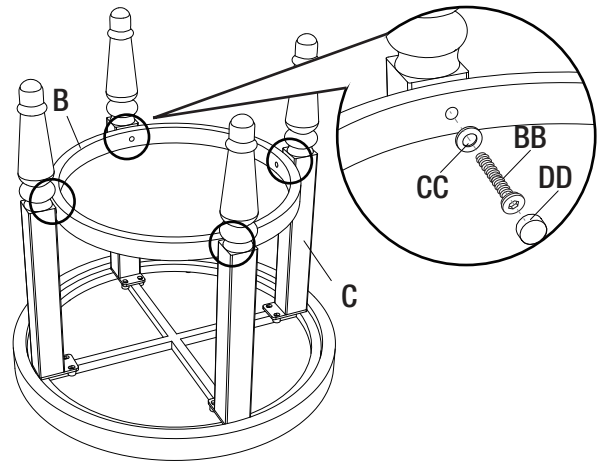

3 Turning the table over

- Turn the table over and set on the ground.

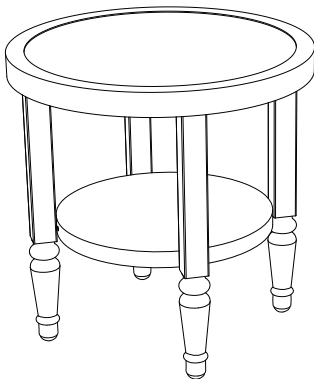

Care and Cleaning

- Do not allow water to build up in the frames. This will cause corrosion and possible freezing damage in cold climates.
- Use a mild soap and water for normal cleaning. Do not use janitorial or alcohol based cleaners. Some cleaners may be marked as natural, but some ingredients may cause discoloration or have an adverse reaction to your finish.
- Rinse with clean water and dry with a soft, absorbent cloth towel.
- Use and operation: To improve the lifespan of this furniture, cover when not in use and store in a dry place in the off season.

HAMPTON BAY®

Questions, problems, missing parts? Before returning to the store,
call Hampton Bay Customer Service
8 a.m. – 7 p.m., EST, Monday – Friday, 9 a.m. – 6 p.m., EST, Saturday

1-800-841-1350

HAMPTONBAY.COM

Retain this manual for future use.