

BODY/FRAME REPAIR EQUIPMENT

6 (12) TON POWER-KIT

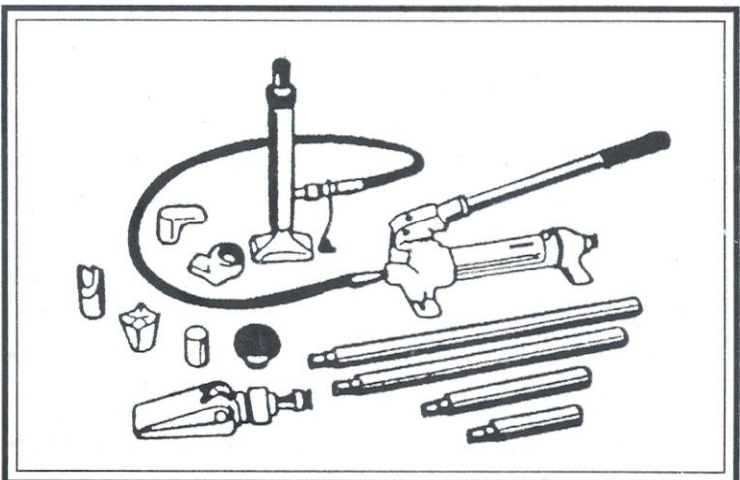

TROUBLESHOOTING CHART

Stop using this equipment immediately if any of the following problems occur, as it may cause personal injury. Any repairs or replacement must be done by a qualified person or an authorized service center only.

PROBLEM	POSSIBLE CAUSE(S)	SOLUTION
When use this equipment, after correctly connection as per operation manual, pump up the handle, the ram doesn't work	1. the steel ball is immersed inside for too long time.	1. Please follow the steps: 1) release the valve, pump up the handle for 10-15 times. 2) Close the valve, pump up the handle for another 5-10 times. 3) Repeat step 1) and 2) for about 3 three times, this problem will be settled.
When use this equipment, after correctly connection as per operation manual, after operation manual, pump up the handle, the ram at first goes up and then descends.	1. unlock of the valve. 2. Scrap iron inside the valve cause unable to be shut off.	1. Tighten the knob of the valve. 2. Please follow the steps: 1) Release the pressure by turning the knob anti-clockwise. pump up the handle 10-15 times. 2) Close the valve. Pump up the handle 5-10 times. 3) Repeat the step 1) and 2), the problem will be settled.
When use this equipment, after correctly connection as per operation manual, the ram is found gradient and the piston rod curved.	1. Uncorrect of connection or unbalance of the footing	1. Stop work immediately, be sure of correct connection of the ram and the base, and put it on the hard ground. Always be secure of its vertical position
Maintenance: After used for 30-50 times, ideal to change the hydraulic oil on the condition of the equipment not on working. Turn on the screw on the rear of the pump, empty the used hydraulic oil, then injecting with fresh oil by oil gun. The recommendatory oil volume is stated below. Do not add oil excessive or the piston rod can not be repositioned normally. If so, turn on the screw on the rear of the pump to discharge unwanted air, then tighten it after the piston rod is repositioned. Available Capacity of hydraulic oil of 4Ton pump 250g±5g Available Capacity of hydraulic oil of 10Ton pump 500g±5g		

HYDRAULIC BODY/FRAME PUMP

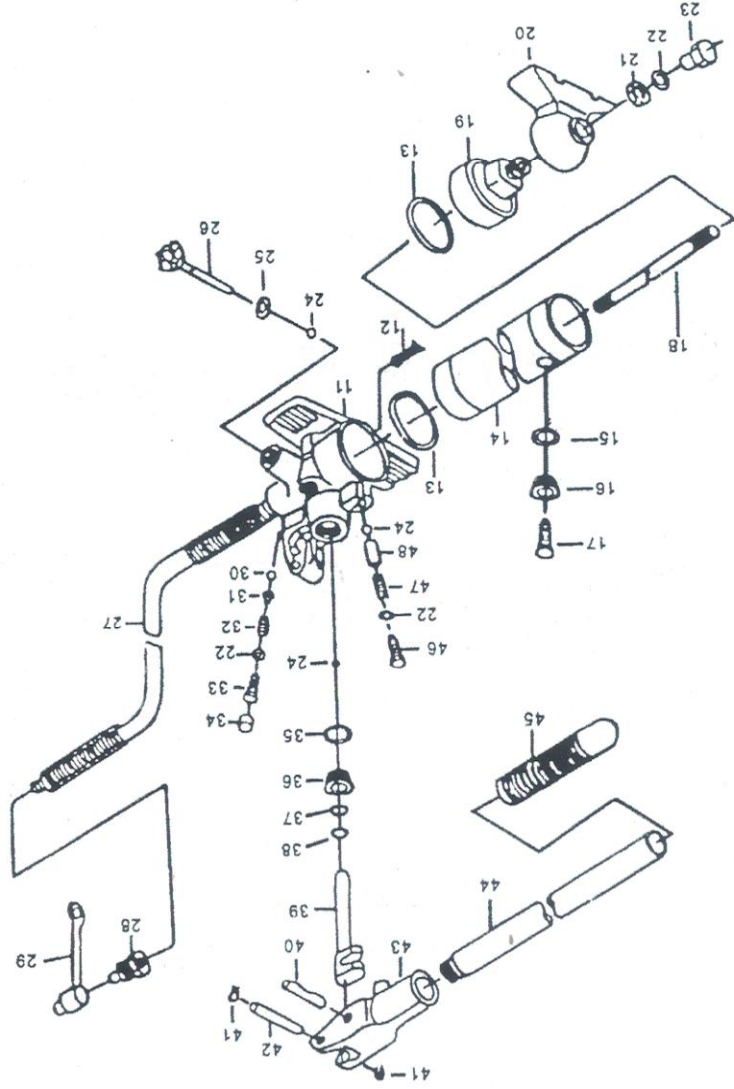

- 5 -

PARTS LIST

Part No.	Description	QTY	Patr No.	Description	QTY
01	Metal Box	1	21	Nut	1
02	Tube	4	22	O-Ring	4
03	Base	1	23	Screw	1
04	Spreader Ram Toe	1	24	Ball	3
05	Plate Head	1	25	O-Ring	1
06	Wedge Head	1	26	Release Valve	1
07	Square Head	1	27	Hydraulic Hose	1
08	Movable Connection	1	28	Coupler	1
09	Serrated Saddle	1	29	Dust Proof Cover	1
10	Rubber Head	1	30	Ball	1
11	Valve Block	1	31	Ball Cup	1
12	Oil Filter	1	32	Spring	1
13	O-Ring	2	33	Screw	1
14	Reservoir	1	34	Screw Protector	1
15	Ring	1	35	O-Ring	1
16	Nut	1	36	Screw	1
17	Breathe Valve	1	37	Nylon Sealing Ring	1
18	Tie Rod	1	38	O-Ring	1
19	Reservoir Cover	1	39	Piston	1
20	Pump Foot	1	40	Pin	1

- 2 -