



User Manual

Model: FI8910W

Indoor Pan/Tilt Wireless IP Camera



Color: Black



Color: White

Table of Contents

Security Warning.....	3
1 Overviews.....	3
1.1 Key Features.....	4
1.2 Read Before Use.....	5
1.3 Packing Contents.....	5
1.4 Physical Description.....	5
1.5 Hardware Installation.....	7
2 Surveillance Software GUI.....	7
2.1 Login Window.....	8
2.2 Surveillance Window.....	10
3 Advanced Camera Settings.....	18
3.1 Device Status.....	19
3.2 Alias Settings.....	20
3.3 Date & Time Settings.....	21
3.4 User Settings.....	22
3.5 Multi-Device Settings.....	22
3.6 Basic Network Settings.....	29
3.7 Wireless Settings.....	32
3.8 ADSL.....	36
3.9 UPnP Settings.....	36
3.10 DDNS Service Settings.....	37
3.11 Mail Service Settings.....	41
3.12 MSN Setting.....	42

3.13 FTP Service Settings.....	44
3.14 Alarm Service Settings.....	46
3.15 PT Settings.....	52
3.16 Upgrade Device Firmware.....	53
3.17 Backup & Restore Settings.....	55
3.18 Restore Factory Settings.....	55
3.19 Reboot Device.....	56
3.20 Log.....	56
3.21 Back.....	57
4 Appendix.....	57
4.1 Frequently Asked Questions.....	57
4.2 Default Parameters.....	62
4.3 Specifications.....	62
5 Phone Apps.....	64
6 Obtaining Technical Support.....	64

Security Warning

Safeguarding Your Privacy

Foscam cameras require good security practices to safeguard your privacy. You can help protect your camera by changing the default username and/or password. Input a username and/or password that is at least 8 – 10 characters or longer. Try to use a combination of lower-case and upper-case letters as well as numbers and special characters. The more complex the username and password, the harder it will be to guess by an unauthorized user.

You should update your camera regularly at <http://www.foscam.us/firmware.html>. Make sure your camera has the latest firmware installed for your specific camera model. The latest firmware for Foscam cameras utilizes protection against various types of online hacking, cracking, and unauthorized access. Doing so will make your device more secure, may add features, and will contain bug fixes to make your device work faster.

1 Overviews

FOSCAM FI8910W is an integrated wireless IP Camera with a color CMOS sensor. It combines a high quality digital video camera, with a powerful web server, to bring clear video to your desktop from anywhere on your local network or over the Internet.

The basic function of IPCAM is transmitting remote video on the IP network. The high quality video image can be transmitted with 30fps speed on the LAN/WAN by using MJPEG hardware compression technology.

With flexible 300-degree pan and 120-degree tilt, FI8910W gives users more comprehensive control over a monitored site. FI8910W supports IR-CUT, when light conditions turns poor, the IR cut filter will be automatically removed to accept IR illumination. Meanwhile, the camera switches itself automatically from color to black and white, assuring optimal image quality at all times.

The IPCAM is based on the TCP/IP standard. There is a WEB server inside which could support Internet Explore. Therefore the management and maintenance of your device is simplified by using the network to achieve the remote configuration, start-up and to upgrade the firmware. Controlling the IPCAM and managing images is simplified by using the provided web interface across the network utilising either wired or wireless connectivity.

FOSCAM provides Phone APPs for Android and iPhone users, please search “**Foscam viewer**” and install it through APP Store, then you can view your camera directly as a computer.

1.1 Key Features

- Powerful high-speed video protocol processor
- Color CMOS Sensor
- 300K Pixels
- IR night vision (Range: 8m)
- Pan 300 degree, tilt 120 degree
- Optimized MJPEG video compression for transmission
- Multi-level users' management and passwords definition
- Embedded Web Server for users to visit by IE
- Wi-Fi compliant with wireless standards IEEE 802.11b/g/n
- Supports IR_CUT and the filter change automatically
- Embedded FOSCAM DDNS(dynamic domain name service) Service
- Supports Dynamic IP (DDNS) and UPnP LAN and Internet (ADSL, Cable Modem)
- Motion and Sound detection activates alarm
- Supports image snapshot
- Supports multiple network protocols: HTTP/TCP/IP/UDP/STMP/DDNS/SNTP/DHCP/FTP
- Supports WEP/WPA/WPA2 encryption
- Supports WPS(Wi-Fi Protected Set-up)
- Supports Daylight Saving Time
- Supports MSN
- Supports Gmail as sender on mail service settings
- Supports audio on Firefox, Google Chrome and Safari

- Providing Phone APPs for Android and iPhone users
- Providing Central Management Software to manage or monitor multi-cameras

1.2 Read Before Use

Please first verify that all contents received are complete according to the Package Contents listed below. Before the Network Camera is installed, please carefully read and follow the instructions in the Quick Installation Guide to avoid damage due to faulty assembly and installation. This also ensures the product is used properly as intended.

1.3 Packing Contents

• IPCAM×1	• CD×1
• Wi-Fi Antenna×1 (only available for wireless model)	• Quick Installation Guide×1
• DC Power Supply×1	• Security Warning Card × 1
• Mounting bracket×1(option)	• Network Cable×1

1.4 Physical Description

Front Panel



Figure 1.1

- 1 **Speaker:** Built-in speaker
- 2 **LENS:** CMOS sensor with fixed focus lens
- 3 **Infrared LED:** 11 IR LEDs
- 4 **Microphone:** Built-in microphone
- 5 **WIFI Antenna:** Wireless Antenna

Back View

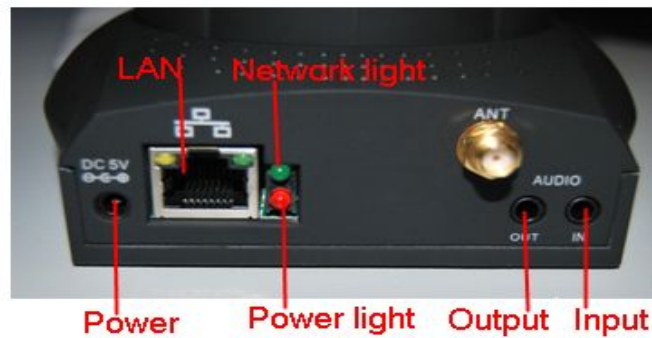

Figure 1.2

LAN: RJ-45/10-100 Base T

Power: DC 5V/2A Power supply

Network Light: The LED will blink when power and network cable are plugged in

Power Light: If the power adapter works well, the light will turn on

Audio Input: This jack is used to plug an external microphone

Audio Output: This jack is used to plug an external speaker

Bottom View

There are some labels located of the camera; this is an important feature of original Foscam cameras. If your camera does not have labels, it may be a clone. Cloned Foscam cameras can not use original firmware and are not eligible for warranty or technical services.

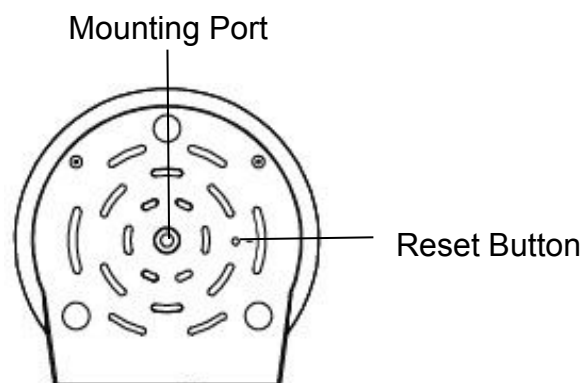

Figure 1.3

Mounting Port

Port for mounting bracket.

Reset button

1) Press and hold down the RESET BUTTON about 10 seconds. when released the IP camera will be reset back to factory default settings. You must power on the camera before reset.

2) Press and hold down the RESET BUTTON about 4 seconds, then press the WPS button on the router, then you can use the WPS function. (For more details: please read Wireless Settings in the User Manual).

1.5 Hardware Installation

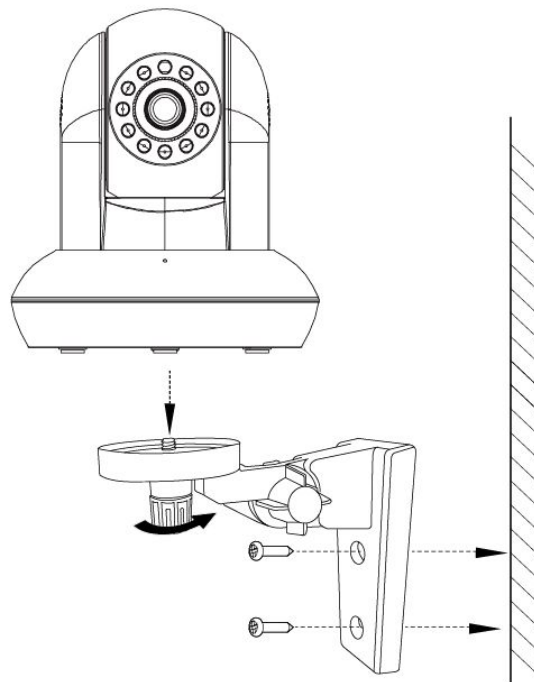

Step 1: Fix the bracket on the wall with 2 screws. We have provided the screws in package.

Step2: Adjust the bracket to make the camera facing to the monitoring area.

Step3: Manually tighten the screws to lock the camera and the bracket.

2 Surveillance Software GUI

Please refer to the Quick Installation Guide if you install the camera at first time. After finishing

quick installation, you can take time to learn the operation of the software.

2.1 Login Window



Figure 2.1

Section1 Select Language

FOSCAM camera supports up to multi-languages, such as English, Spanish, Deutsch and so on. You can select the language you need via pull down the dropdown toolbar and click on the language to switch.

Section2 User / Password

The default administrator username is admin with a blank password, please reset the password at first using and prevent unauthorized users login the camera.

NOTE:

When you log in for the first time, it will request that you modify the default username and/or password . Input the New username, New password and Confirm the password, click “Confirm” to complete the modification. You will now use the new username and password to log in to the camera in the future.

The image shows two screenshots of the Foscam web interface. The top screenshot is a registration form with three input fields: 'New username', 'New password', and 'Confirm the password', each followed by a text box. A 'Confirm' button is located below the fields. The bottom screenshot shows the login mode selection screen. It features the Foscam logo and website URL (www.foscam.us) in the top right corner, labeled '1'. Below the logo are three buttons: 'ActiveX Mode' (labeled '2'), 'Server Push Mode' (labeled '3'), and 'Mobile Phone' (labeled '4'). At the bottom, there is a 'Note' box (labeled '5') containing the following text: 'Please note that there are three login methods: for IE browser, please choose ActiveX mode; for Safari, Firefox, Google Chrome, please choose Server Push mode; for mobile phone, please choose the third mode.'

Figure 2.2

Section 1 FOSCAM Website Link

There is an access link to Foscam website homepage, if you need tech support you can contact Foscam directly.

Section 2 ActiveX Mode

If your PC is windows based OS, such as Windows XP, Windows7, Windows Vista and you are using IE-based browsers like IE6, IE7, IE8, please choose IE ActiveX Mode login mode.

Section 3 Server Push Mode

If you are using non-IE based browser, like Firefox, Safari, Google Chrome please choose

Server Push Mode.

Section 4 Mobile Phone

If you are using the Mobile to access the camera, here you need to select Mobile Phone login mode.

Section 5 Note

Note that when you login the camera, please select the corresponding login mode.

2.2 Surveillance Window

Select the ActiveX mode and you will enter the surveillance window.



Figure 2.3

Section1 Device Name

Default device name is Anonymous. You can define a name for your camera as you like (Please go to chapter 3.1 and read how to set it)

Section2 Multi-Device Window



The firmware inside the camera supports up to maximum of 9 cameras being monitoring at the same time. You can add other cameras in multi-device setting (read chapter 3.5).



Figure 2.4

Section3 Image Parameters Settings



OSD

OSD is used to add timestamp on the video. There are five text colors to choose from: Black, red, yellow, white, blue.

Add OSD on record

Select this option if you want to add a timestamp to recordings.

Resolution

- 1) 320x240-----QVGA
- 2) 640x480-----VGA

There are two resolutions, the bigger one (VGA) is 640x480 pixels, and the smaller one (QVGA) is 320x240 pixels. The bigger the resolution, the better of the image quality is, but the lower the frame rate is. If you are accessing the camera via internet and want to get more fluent video streaming, please select resolution QVGA 320x240.

Mode

- 1) 50HZ -----Indoor surveillance (Region: Europe, China)
- 2) 60HZ -----Indoor surveillance (Region: USA, Canada)
- 3) Outdoor-----Outdoor surveillance (Region: All over the world)

There are three options within the menu of Mode: 50HZ, 60HZ and Outdoor. It depends on the frequency of the electricity and surveillance model (indoors & outdoor). Please choose outdoor mode, when the camera was installed outside.

Fps

- 1) Max----- Maximum frame rate
- 2) 20fps, 15fps, 10fps, 5fps,4fps,3fps,2fps,1fps, 5fps, 1fps ,1/2fps,1/3fps,1/4fps,1/5fps-----
customized frame rate

You can choose option within the menu of Fps to adjust the frame rate. It is often used in LAN network when you want to lower the frame rate, so that you can save more bandwidth.

Brightness

Default parameter is 6, you can adjust the brightness of the image by clicking plus or minus button.

Contrast

Default parameter is 4, you can adjust the contrast of the image by clicking plus or minus button.

Preset/Go

- 1) Preset-----Support 8 preset position, which is considered enough for DIY home & small business surveillance market
- 2) Set----- Click Set to save the position you need the camera to remember
- 3) Go----- Click Go to make the camera move the preset position
- 4) Number button from 1 to 8-----You can click the number button with preset position, and the camera will go to the preset position.

How to do preset position?

We can start preset settings from position 1.

Firstly, select no. 1 within the menu of Preset on the panel.

Secondly, move the camera and stop at a place where you want make preset position.

Thirdly, click set button to save it as position 1 and you have done preset of position 1.

After that, you can select no. 2 within the menu of Preset on the panel, and move the camera and stop at another place, and set as preset position 2. You can do all the 8 preset positions with this method.

If you want to see the preset position you have set, such as the position 1, only select the set no.1 ,and click go button, the camera will go to position no.1.

Flip & Mirror

You can flip the image by enabling Flip button, or mirror the image by enabling Mirror button.

Section4 Pan/Tilt Control

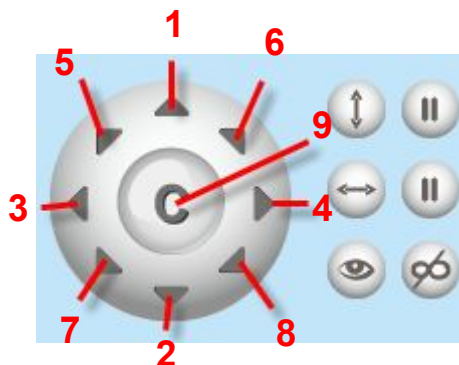

1----Up control button

3----Left control button

5----Up-Left control button

2----Down control button,

4----Right control button,

6----Up-Right control button

7----Down -Left control button

8----Down-Right control button

9----Go to center



: Click this icon; camera will rotate up and down. Click  to stop.



: Click this icon; camera will rotate left and right. Click  to stop.





: Click this icon, all the IR lights will turn on. Click  to turn off them.

Section5 Device Management

Device Management -----Path to Administrator Control Panel, Click it, and it will lead to Administrator Control Panel

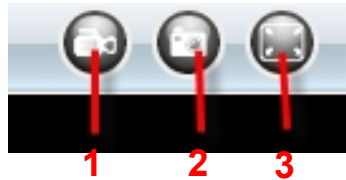
Section6 Record & Snapshot & Full Screen Buttons



1-----Record Button Click it and it pop-up a path-setting window, you can select the storage path and the record file name. At the same time the record icon changes to  Click it again and stop recording.

2-----Snapshot Click it to make snapshot and it pop-up a window which picture you snapshot, right click in the window and save the picture to anywhere you want.



3-----Full Screen Click it to make full-screen, or you can double click the surveillance screen to make full-screen.

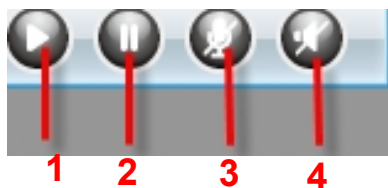

Section7 Play/Stop/ Talk and Audio Buttons



1-----Play Click it to play the video of the camera

2-----Stop Click it to stop the video of the camera

3----- Talk Button Click the talk icon , and the icon changes to , then talk through your computer's microphone which will transmit through the camera's speaker. People will hear your talking through the camera's built-in speaker. Click the icon again and stop talking.

4-----Audio Button Click the audio icon , and it changes to , then you will hear sound

captured by the camera's built-in microphone. You may need to plug in earphones or enable the computer speakers to hear from the camera's microphone.

Onscreen Mouse Control

Double click right mouse on the surveillance window, then left click on the screen to indicate the camera move direction you prefer, press the left mouse and the camera' Len will move to the corresponding direction.. Double click right mouse again, cancel onscreen mouse control.

For example, double click right mouse, then left click on the up corner of the screen, you can see the arrow, press the left mouse, and the camera's lens will moving towards the up direction.

Double click right mouse again, cancel onscreen mouse control.



Figure 2.5

NOTE:

Record and multi-device function are controlled by ActiveX controller, therefore Firefox or Google Chrome, Safari browsers will not allow these functions.

For Firefox, Google Chrome, Safari, you should select the Server Push Mode and you can see the following screen:

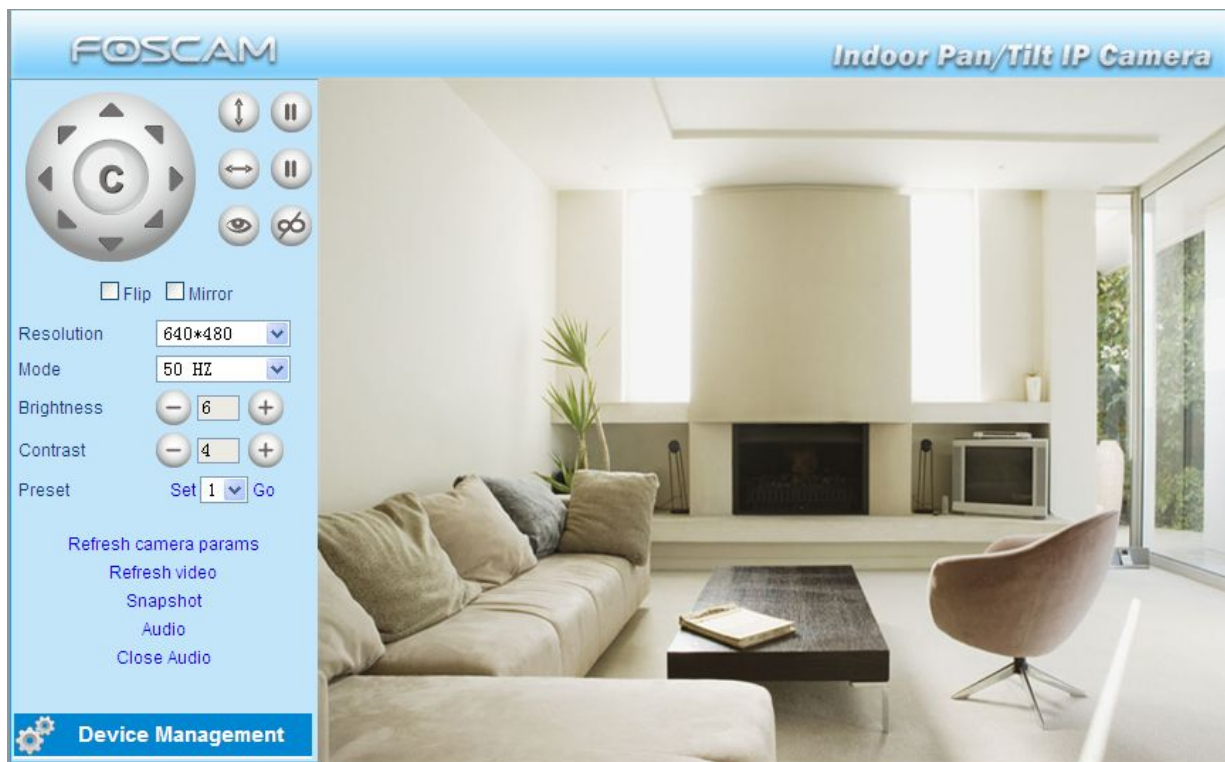

Figure 2.6

For the first time using audio, you need to download and install VLC plugin, Click Audio, and you can see the download website.

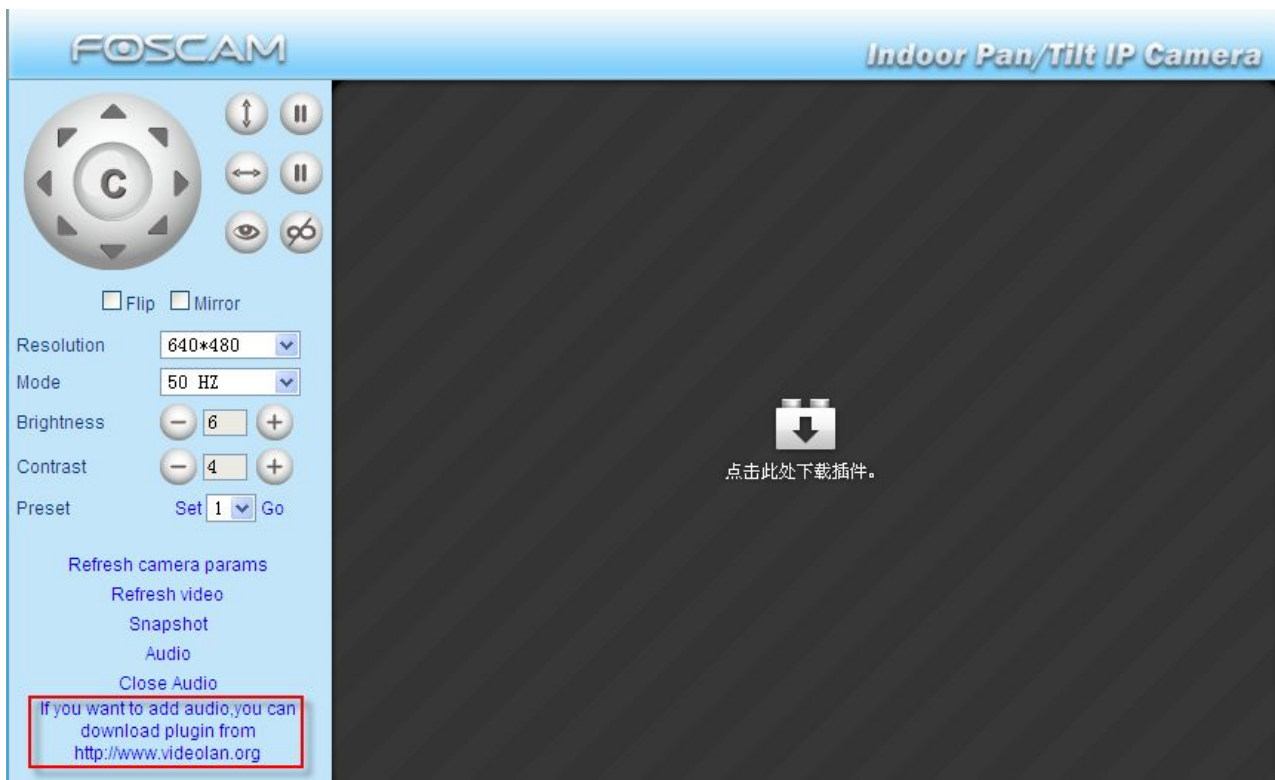

Figure 2.7

During the installation, you must select Mozilla plugin as in Figure 2.8.

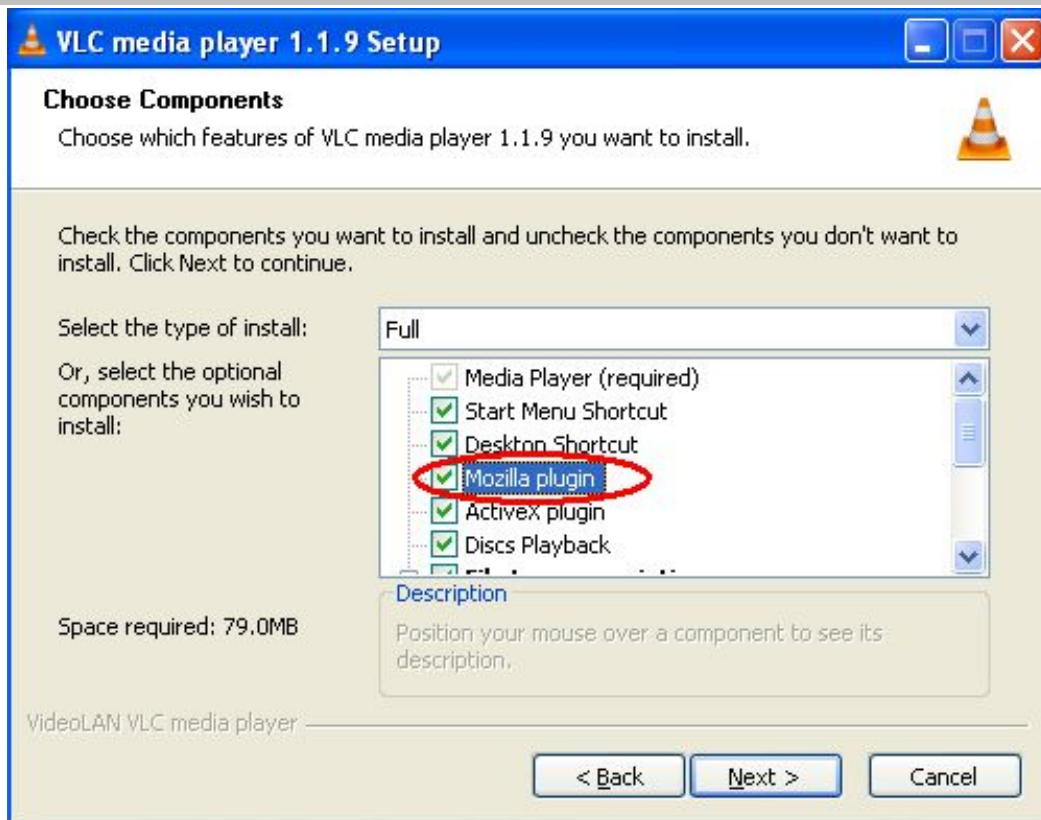

Figure 2.8

3 Advanced Camera Settings

Click the bar "Device Management", goes to Administrator Control Panel to make advanced camera settings.

3.1 Device Status



Figure 3.1

- 1-----**Device ID** MAC ID of the camera by wired connection
- 2-----**Device Firmware Version** System Firmware version of the camera
- 3-----**Device Web UI Version** Web UI firmware version of the camera
- 4-----**Alias** Name of the camera
- 5-----**Alarm Status** The status of Alarm Service Setting
- 6-----**DDNS Status** The status of DDNS Setting
- 7-----**UPnP Status** The status of UPnP Setting
- 8-----**MSN Status** The status of MSN Setting

Another Way:

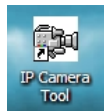

Double click the the icon “IP Camera.exe” , select the camera IP, right click and select the Basic Properties, you can also see the Firmware Version and MAC Address, such as the following screen:

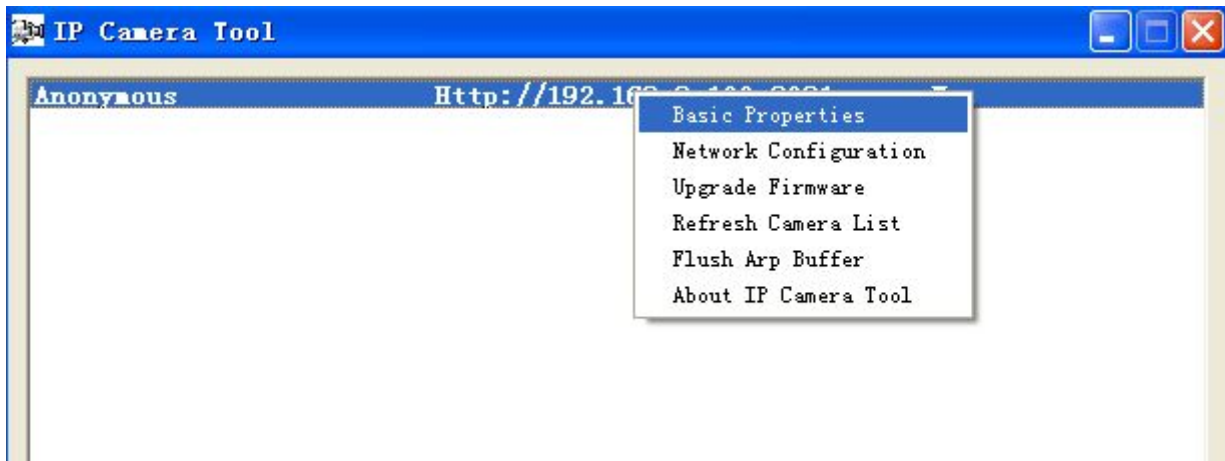

Figure 3.2

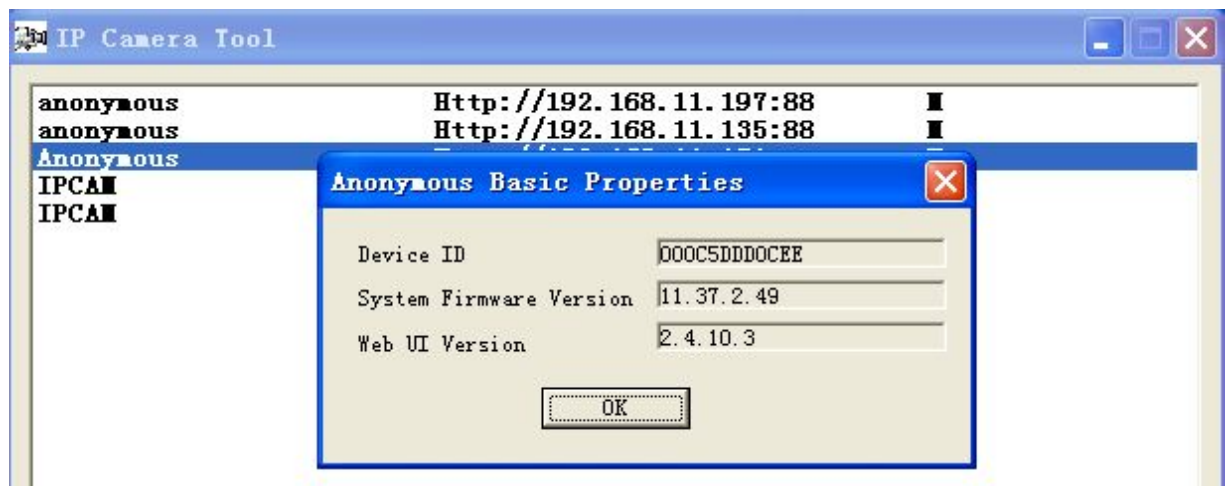

Figure 3.3

3.2 Alias Settings

Default alias is Anonymous. You can define a name for your camera here such as apple. Click **Submit** to save your changes. The alias name supports special characters.

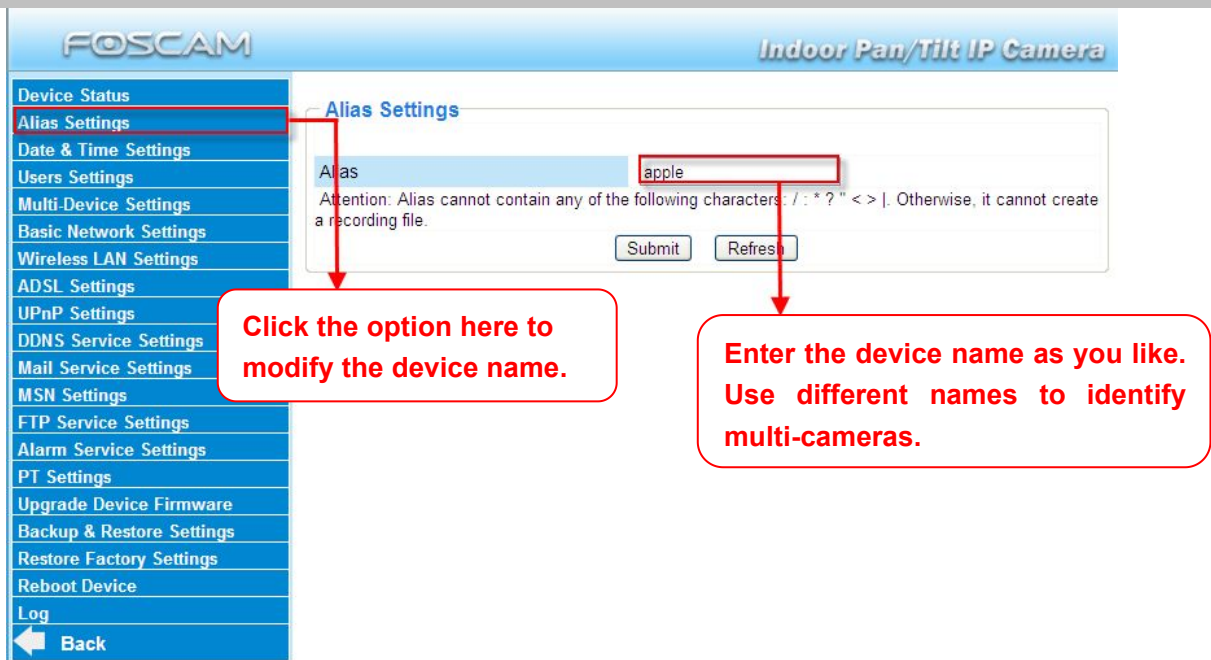

Figure 3.4

3.3 Date & Time Settings

Choose the time zone of your country. You can choose **Sync with NTP Server** or **Sync with PC Time**. If your country implements the **Daylight Saving Time**, that option can also be selected.

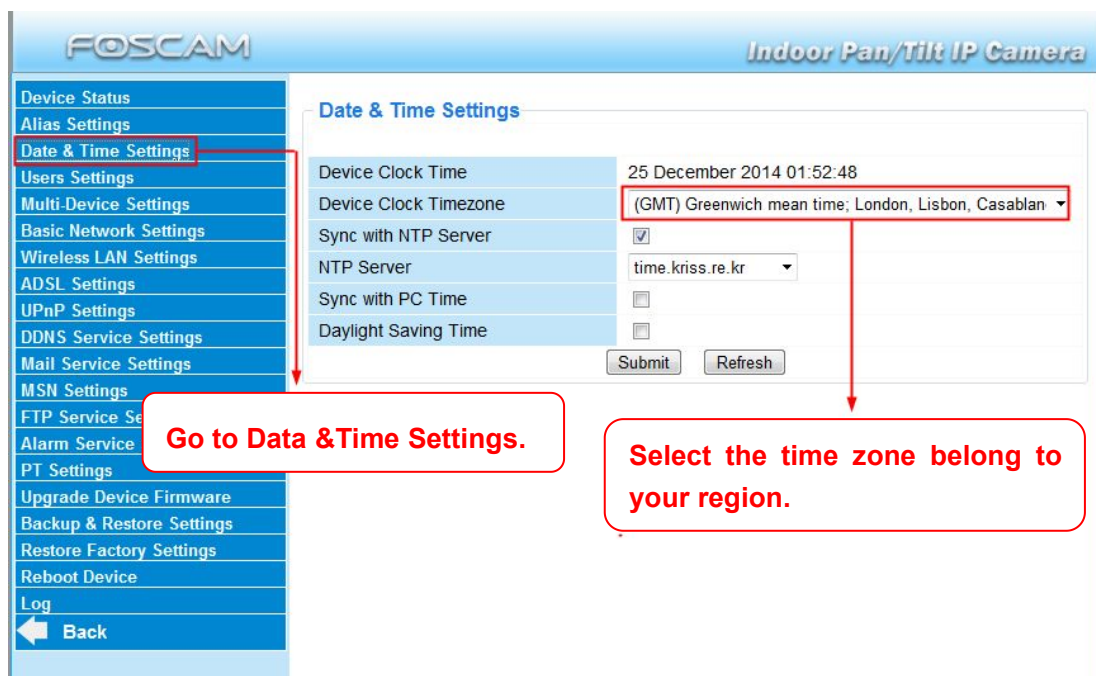

Figure 3.5

3.4 User Settings

Here you can create users and set permission levels, **visitor**, **operator** or **administrator**.

Click **Submit** to save these settings. The camera will reboot.

The screenshot shows the 'Users Settings' page in the Foscam web interface. The sidebar on the left lists various settings categories. The main area contains a table for user management:

User	Password	Group
admin		Administrator
user	•••••	Operator
visitor		Visitor
		Visitor
		Visitor
		Visitor
		Visitor
		Visitor
		Visitor
		Visitor

Below the table is the 'Set Alarm Record Path' section, which includes a text input field with the path 'C:\Documents and Settings\All Users\l' and a 'Browse...' button.

Figure 3.6

Here you can also set one important file locations for the camera, the **Alarm Record Path**. Simply click **Browse** and choose the path to the required folder.

The **Alarm Record Path** location is used to store automatically recorded files when the camera is activated by motion or sound. (See set motion/sound alarm.) The default path for **Alarm Record Path** is C:\Documents and Settings\All Users\Documents.

NOTE: In Windows7 or Vista, if you cannot set the paths.:

Windows7 or Vista's security level is higher than Windows XP/2000. For "set record path" function, user should add the Device IP address to the Internet Explorer's 'Trusted sites' first. The step is: IE browser → Tool → Internet Proper → Security → Trusted sites → Sites → Add

3.5 Multi-Device Settings

If you want to view multi-surveillance screens on one window, you need to login one camera, and set it as the main device, and do Multi-Device Settings, add other cameras to the first one

camera. Before you do multi-cams settings, you need to assign different port such as 81, 82, 83, 84, 85, 86, 87, 88 to the cameras if there is 8 cams installed.

The firmware within the camera can support a maximum of 9 devices monitoring all at the same time.

3.5.1 Add cameras in LAN

In Multi-Device Settings page, you can see all devices searched in LAN. The 1st Device is the default one. You can add more cameras in the list in LAN for monitoring. The camera's software supports up to 9 IP Cameras online simultaneously. Click **The 2nd Device** and click the item in the **Device List in LAN**, the Alias, Host and Http Port will be filled in the boxes below automatically. Enter the correct username and password then click **Add**. Add more cameras in the same way. After all cameras have been added, choose **Submit**.

Multi-Device Settings

Device List in LAN	Foscamdemo8918(192.168.11.206) Foscamdemo FI8910W(192.168.11.211) FoscamdemoFI8916W(192.168.11.208) Anonymous(192.168.11.169)
	<input type="button" value="Refresh"/>
The 1st Device	This Device
The 2nd Device	None
Alias	FoscamdemoFI8916W
Host	192.168.11.208
HTTP Port	8916
User	admin
Password	
	<input type="button" value="Add"/> <input type="button" value="Remove"/>
The 3rd Device	None
The 4th Device	None
The 5th Device	None
The 6th Device	None
The 7th Device	None

1 Click it, alias, host and HTTP Port will be filled in the following boxes automatically.

2 Enter the User name and password of the 2nd camera.

3 Click Add to take effect.

Figure 3.7a

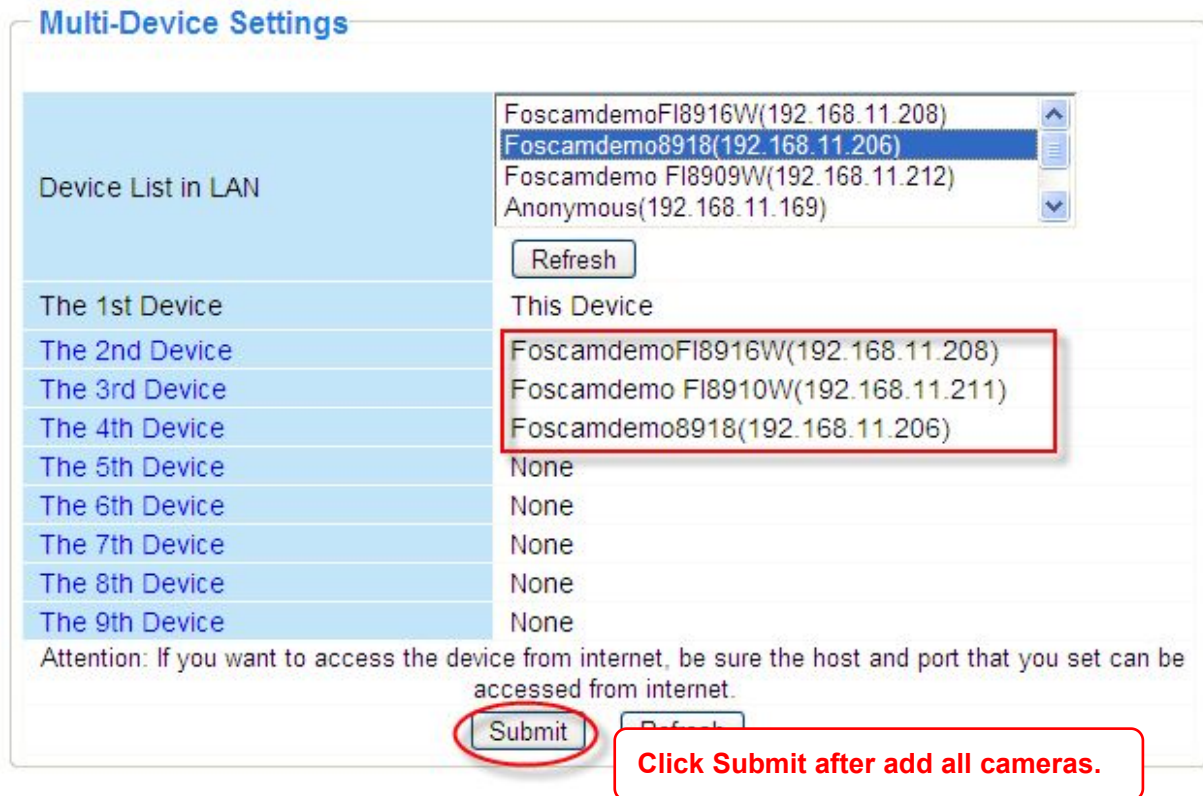

Figure 3.7b

Back to **Surveillance Windows**, and click Four Windows option, you will see four cameras you added.



Figure 3.8

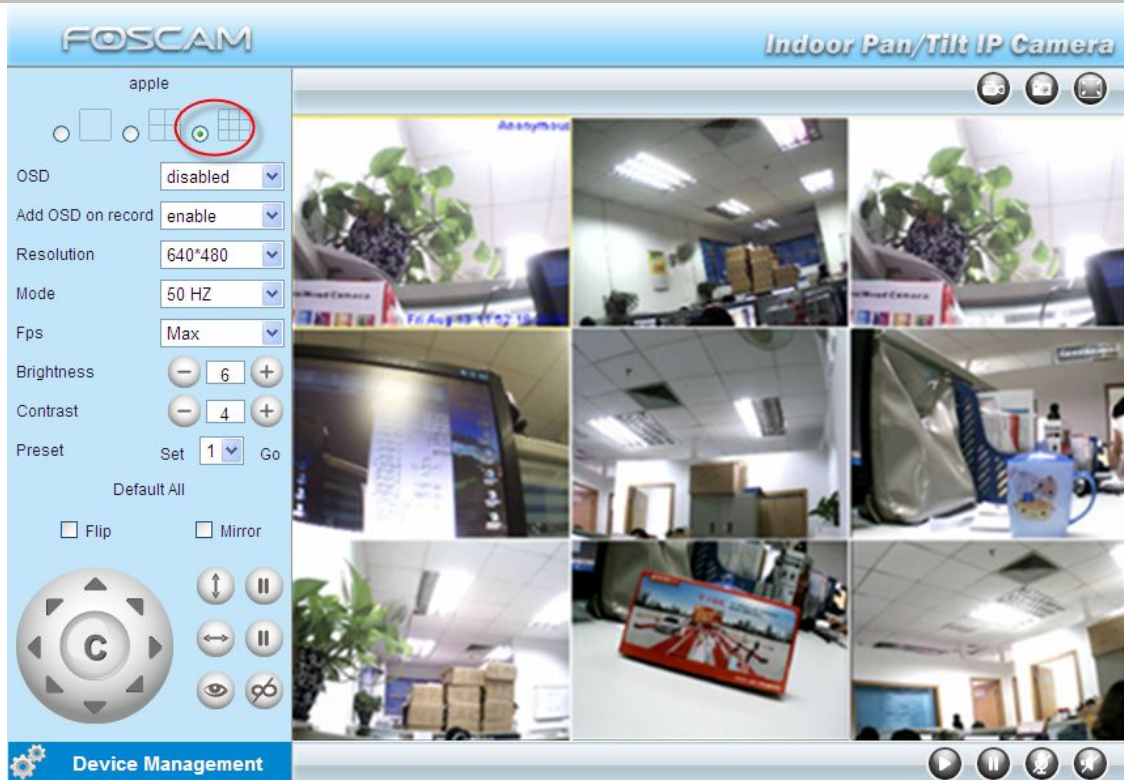

Figure 3.9

3.5.2 Add cameras in WAN

If you want to view all cameras via the internet(remote computer), you will need to add them using DDNS domain name. Firstly, make sure all of the cameras you added can be accessed through the internet. (Read **How to configure DDNS settings** in **chapter 3.10**)

Login to the first camera using a DDNS domain name and port.

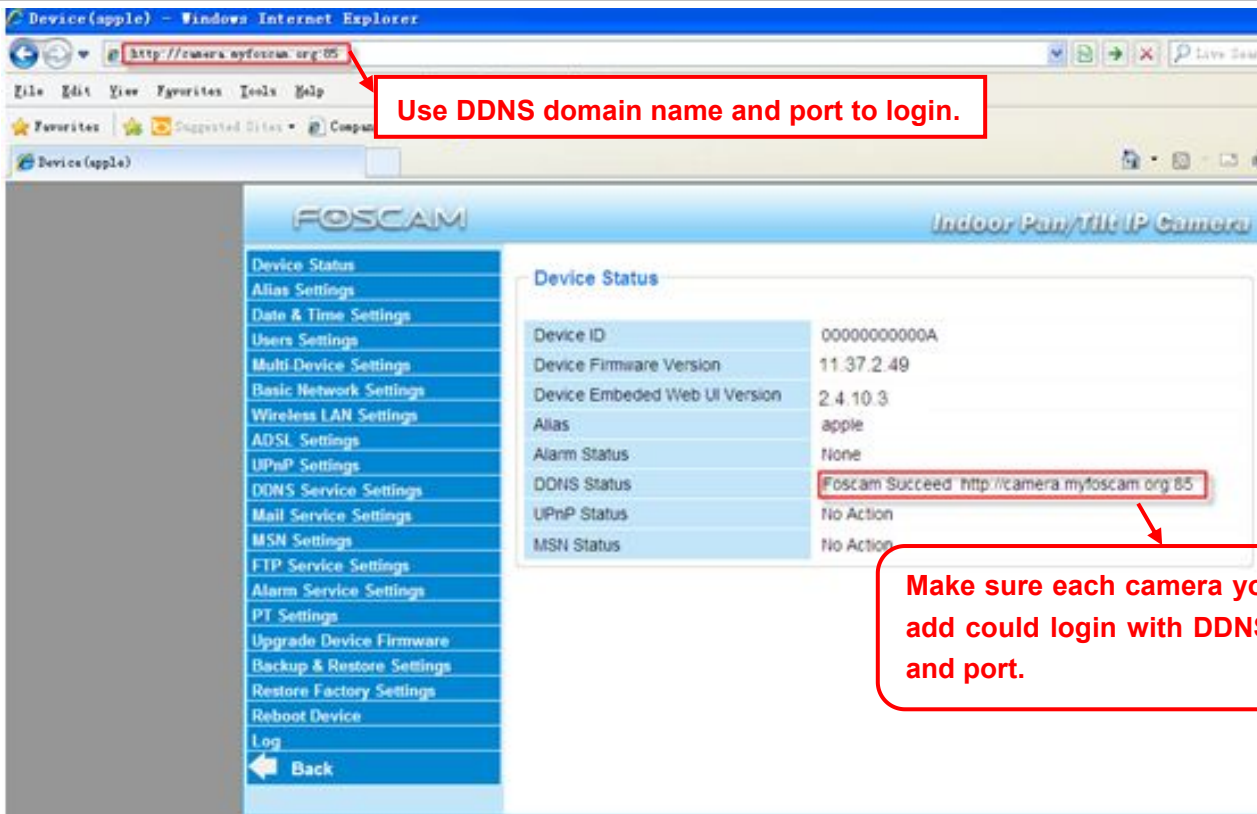

Figure 3.10

If you have several cameras, you can use the same DDNS domain name; you only need to set a different port number for each camera.

Click **Multi-Device Settings**. Choose **The 2nd Device**. Fill in the 2nd camera's name, DDNS domain name, port number. Enter user name and password and then choose Add. (Figure 3.11)

NOTE: Here the Host must be entered as the second camera's DDNS domain name, not its LAN IP.

Multi-Device Settings

Device List in LAN	Foscamdemo FI8909W(192.168.11.212) Foscamdemo FI8904W(192.168.11.214) Anonymous(192.168.11.169) Foscamdemo FI8910W(192.168.11.211)
	<input type="button" value="Refresh"/>
The 1st Device	This Device
The 2nd Device	None
	Alias <input type="text" value="sarah"/> → 1 Host <input type="text" value="ipcam.dyndns.org"/> → 2 HTTP Port <input type="text" value="8090"/> User <input type="text" value="admin"/> → 3 Password <input type="password" value="..."/>
	<input type="button" value="Add"/> → 4 <input type="button" value="Remove"/>
The 3rd Device	None
The 4th Device	None
The 5th Device	None
The 6th Device	None
The 7th Device	None

Figure 3.11

- 1---- The 2nd camera's name
- 2---- Fill in the 2nd camera's DDNS host not LAN IP
- 3---- Enter the 2nd camera's user name and password
- 4---- Click Add button and to take effect

Add the other cameras in the same way. Click **Submit** to save.

Multi-Device Settings

Device List in LAN	
	FoscamdemoFI8916W(192.168.11.208)
	Anonymous(192.168.11.169)
	Foscamdemo8918(192.168.11.206)
	Foscamdemo FI8904W(192.168.11.214)
	<input type="button" value="Refresh"/>
The 1st Device	This Device
The 2nd Device	sarah(ipcam.dyndns.org)
The 3rd Device	apple(ipcam.myfoscam.org)
The 4th Device	linla(test1.myfoscam.org)
The 5th Device	None
The 6th Device	None
The 7th Device	None
The 8th Device	None
The 9th Device	None

Attention: If you want to access the device from internet, be sure the host and port that you set can be accessed from internet.

Click submit after finishing all settings.

Figure 3.12

Return to video window. You will see all of the cameras accessible through the internet.

When you are away from home, you can use the first camera's DDNS domain name and port to view all the cameras via internet.

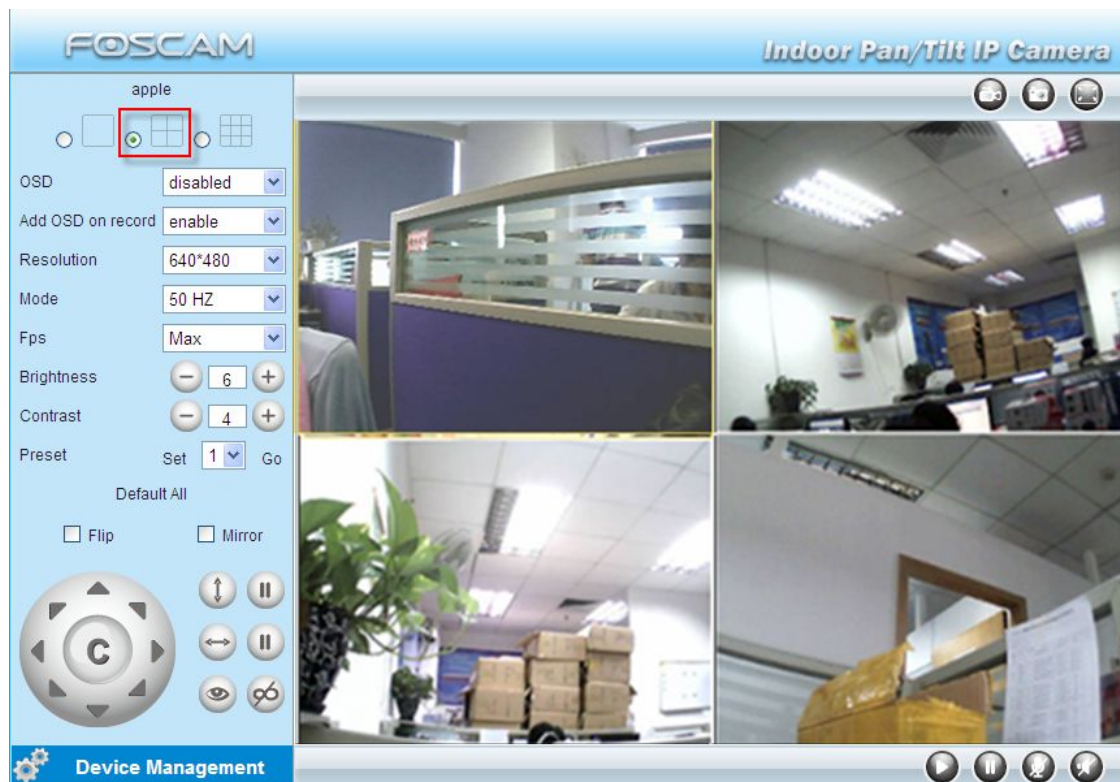

Figure 3.13

3.6 Basic Network Settings

If you want to set a static IP for the camera, select **Basic Network Settings**. Keep the camera in the same subnet of your router or computer.

The screenshot shows the Foscam web interface for an Indoor Pan/Tilt IP Camera. The sidebar menu on the left includes the following options: Device Status, Alias Settings, Date & Time Settings, Users Settings, Multi-Device Settings, Basic Network Settings (highlighted), Wireless LAN Settings, ADSL Settings, UPnP Settings, DDNS Service Settings, Mail Service Settings, MSN Settings, FTP Service Settings, Alarm Service Settings, PT Settings, Upgrade Device Firmware, Backup & Restore Settings, Restore Factory Settings, Reboot Device, Log, and a Back button. The main content area is titled 'Basic Network Settings' and contains the following configuration options:

Obtain IP from DHCP Server	<input type="checkbox"/>
IP Address	192.168.0.109
Subnet Mask	255.255.255.0
Gateway	192.168.0.1
DNS Server	192.168.0.1
HTTP Port	85
Network Lamp	<input checked="" type="checkbox"/>

At the bottom of the form are 'Submit' and 'Refresh' buttons.

Figure 3.14

Changing settings here is the same as using the IP Camera Tool. (Figure 3.17/3.18)

It is recommended that you use the subnet mask, gateway and DNS server from your locally attached PC. If you don't know the subnet mask, gateway and DNS server, you can check your computer's local area connection as follows:

Control Panel→**Network Connections**→**Local Area Connections** →Choose **Support**→**Details**.

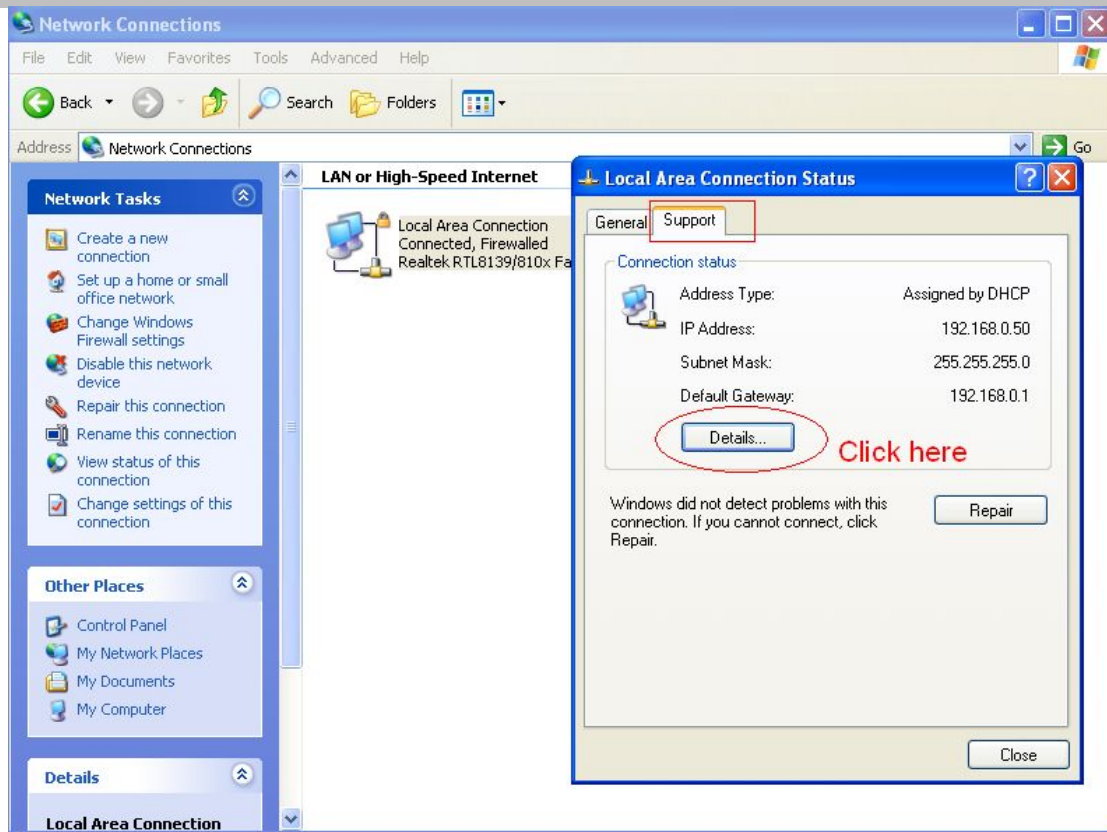

Figure 3.15

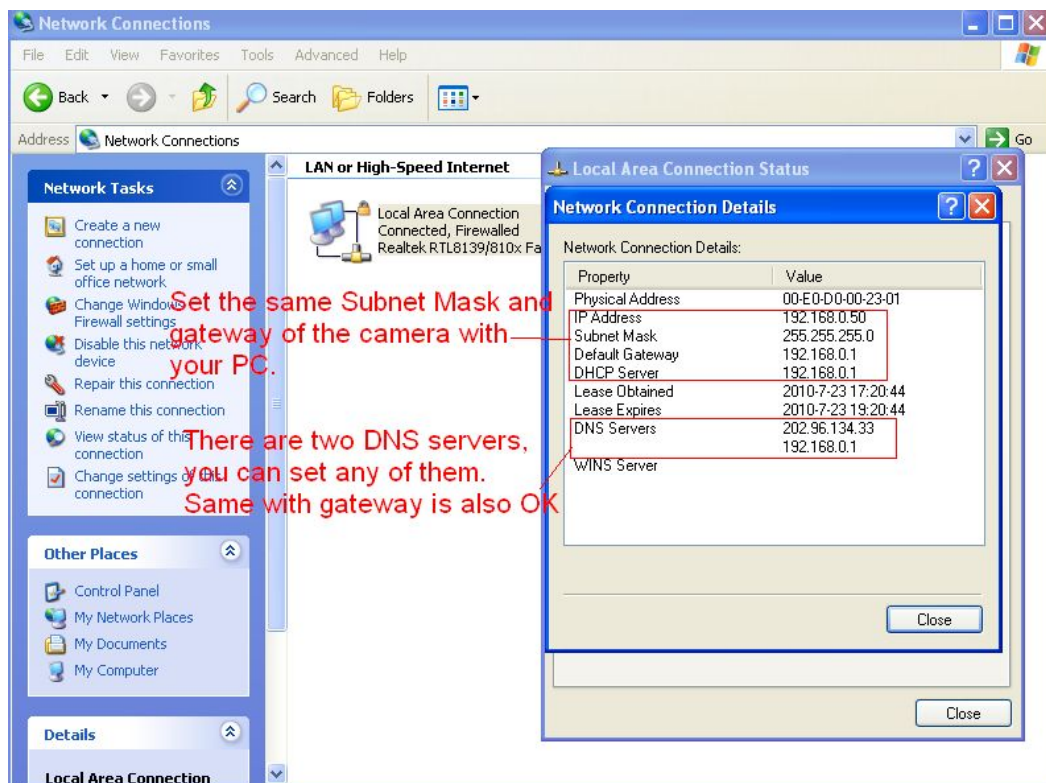

Figure 3.16

If you don't know the DNS server, you can use the same settings as the Default Gateway.

Network lamp: There is a network lamp on the back of the camera, select it and when the

network connection are working, the lamp will turn on and blink.

Another way to change the camera's LAN IP and HTTP Port no.

Open the IP Camera Tool, select the camera you want to change the port no, right click on the IP address link, and goes to Option "Network Configuration", it pops up another dialogue showed as the following screen

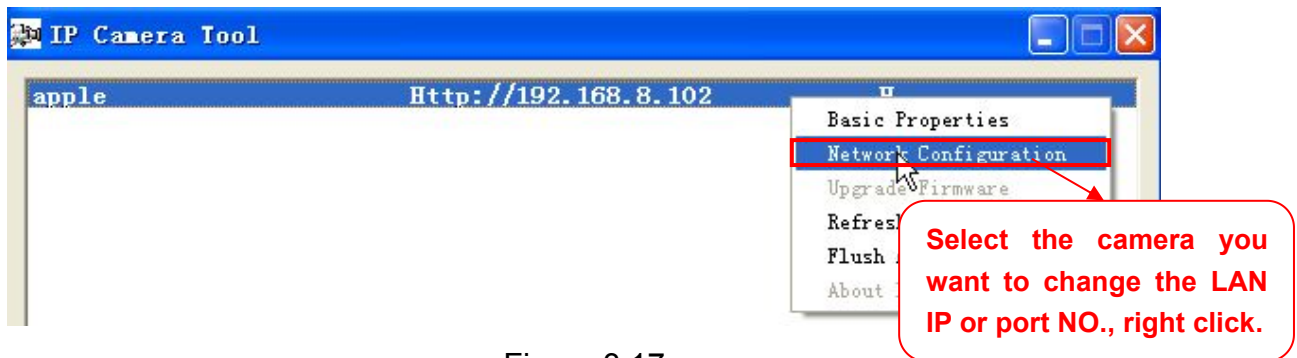

Figure 3.17

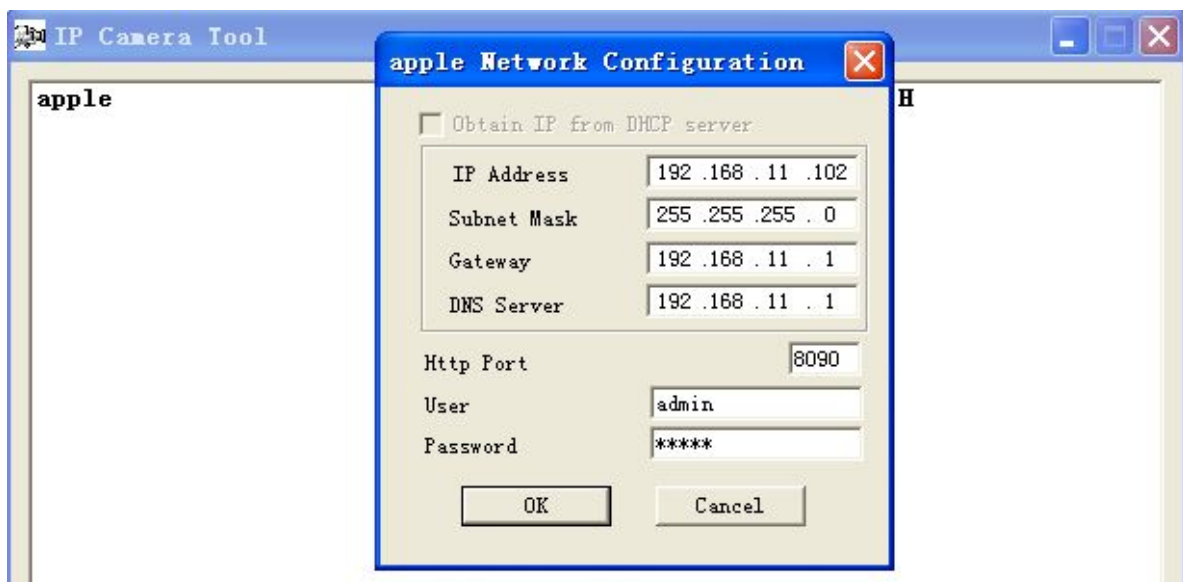

Figure 3.18

IP Address: Fill in the IP address assigned and make sure it is in the same subnet as your computer or router. (I.e. the first three sections are the same)

Subnet Mask: The default subnet mask of the equipment in our LAN is: 255.255.255.0. You can find the subnet mask in the basic information of your router or the locally-attached of your PC.

Gateway: Make sure it is in the same subnet with PC's IP address. The gateway is your router's LAN IP.

DNS Server: IP address of your ISP network provider. You can find the DNS server in your

router or check the locally-attached address of your computer. Your PC contains your PC's IP address, gateway and DNS server. Normally, there are two DNS servers. Here you can also set the DNS server the same with gateway.

Http Port: The default Lan port is 80. You can set another port number, such as port 8005, 8100.etc.

User&Password: Default administrator user name is admin with no password.

NOTE:

If the prompt "Subnet doesn't match, dbclick to change!" appears, please enable DHCP set camera's IP address and gateway once again.

3.7 Wireless Settings

Wireless Lan Settings support three modes: Infra(Do wireless lan settings manually) and WPS (Wi-Fi Protected Set-up) and Adhoc.

If your router does not support WPS function, please go to chapter 3.7.1 and make wireless connection settings manually.

If your router supports WPS function, please go to chapter 3.7.2 and make wireless connection settings quickly.

If there is no wireless router, please go to chapter 3.7.3 and connect the IPCAM directly to a host in a peer_to_peer environment.

3.7.1 Infrastructure Mode

Step 01) Please choose "Device Management" and goes to the option **Wireless LAN Settings** , click "**Wireless LAN Settings**". Then enable "**Using Wireless LAN**".

Click the Scan button and the camera will detect all WIFI devices around the area. It should also display your router in the list. (Figure 3.19)

Wireless LAN Settings

Wireless Network List	lucy[14e6e462d576] infra dlink[f07d685630dc] infra test1[54e6fc35f13a] infra WEP cisco[00259cb1df9a] infra WEP
Using Wireless LAN	<input checked="" type="checkbox"/>
SSID	<input type="text"/>
Network Type	Infra
Encryption	None
<input type="button" value="Submit"/> <input type="button" value="Refresh"/>	

Click Scan Button to search WIFI device.

Figure 3.19

Step 02) Click the SSID of your router in the list, the corresponding information (SSID & Encryption) will be filled in the following boxes automatically.

You will only need to fill in the share key. Make sure that SSID, Encryption and share key you filled in for the camera are exactly the same for your router.

Wireless LAN Settings

Wireless Network List	lucy[14e6e462d576] infra dlink[f07d685630dc] infra test1[54e6fc35f13a] infra WEP cisco[00259cb1df9a] infra WEP
Using Wireless LAN	<input checked="" type="checkbox"/>
SSID	cisco
Network Type	Infra
Encryption	WPA2 Personal (AES)
Share Key	••••••••
<input type="button" value="Submit"/> <input type="button" value="Refresh"/>	

Click the SSID of router and SSID, Encryption will be filled in the following box automatically.

Enter the same share key with your router.

Figure 3.20

Step 03) Please click on the Submit button after all settings have been entered, the camera will reboot. After the camera has completed the reboot process, wait 10 seconds and disconnect the network cable.

The LAN IP address will disappear on the window of IP Camera Tool when the camera gets

restarted. Just wait for around 1 minute, the camera will get wireless connection, and the LAN IP of the camera will be showed again on the window of the IP Cam Tool. You have done wireless connection of the camera successfully. If the camera has a dynamic IP, after the wireless settings, the IP will be changed.

Note:

If fail to make WiFi connection, please refer to seller or us for help.

3.7.2 WPS (Wi-Fi Protected Set-up)

Step 01) Please use a small round stick or like toothpick to press and hold the RESET button for **four seconds**. .

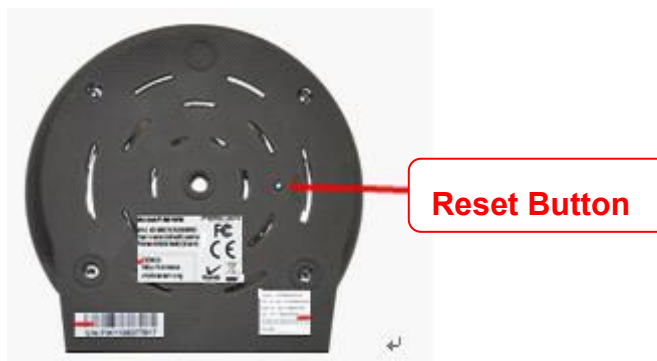

Step 02) Press the WPS button on your router **within 60 seconds**. The WPS button is usually on the back or side of your router. On some routers, you may need to log in to the web interface and click on an on-screen button to activate the WPS feature. If you are not sure where the WPS buttons is on your router, please refer to your router's User Manual.

The camera will automatically create a secure wireless connection to your router. If you have plugged in the network cable, please plug it out. While connecting, the green network light will blink quickly and the wireless settings will take effect. The IP Camera Tool will search the camera's LAN IP. Make sure the PC and the camera share the same subnet.

NOTE:

1 During the WPS Settings, you must press the Reset button only for four seconds, or else, the camera may be reset back to factory default settings if you press and hold on the reset button above 10 seconds.

2 The security mode of router cannot be WEP, or else the WPS settings may be failed.

3.7.3 Adhoc Mode

Under this mode, the IPCAM will directly connect to a host in a peer_to_peer environment.

Make sure the PC has plugged in the wireless network card.

Step 01) Enable wireless and choose Adhoc mode.

Fill in a SSID to identify the IPCAM and then set the security mode, you can choose none or others. Click Apply.

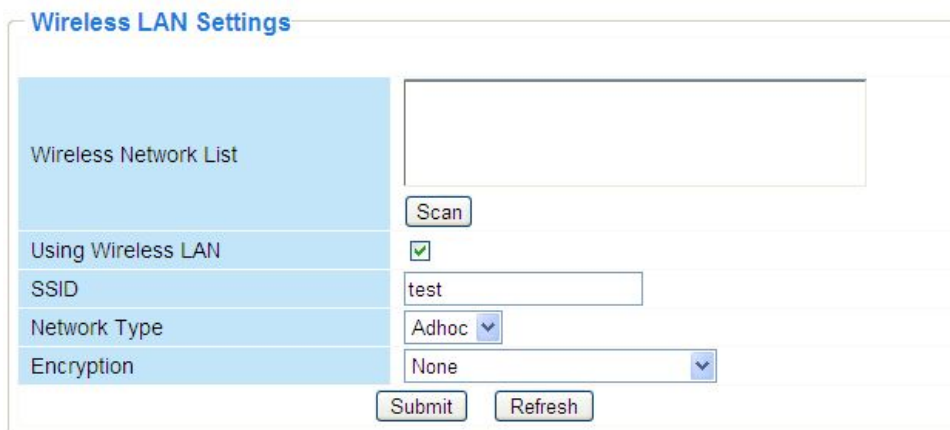

Figure 3.21

Step 02) Plug out the network cable and the camera will restart..

Open the wireless network card of PC and search the wireless network around the area. You can find the SSID you filled for the camera (Figure 3.21).

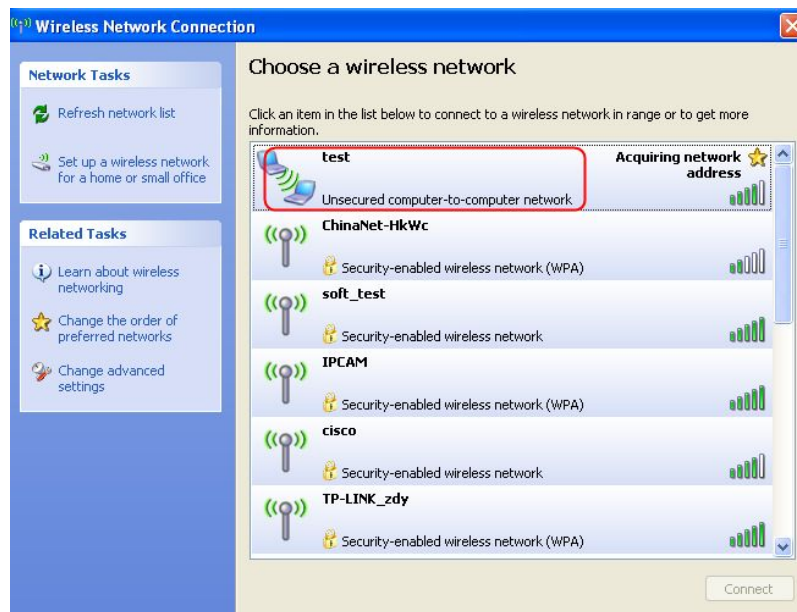

Figure 3.22

Step 03) Disabled the wired connection of the PC. Select the SSID you filled at Figure3.21 for your camera and enter the same key with your camera. Make sure PC and Camera share the

same subnet.

Open the IP Camera Tool, you can search the camera LAN IP again.

3.8 ADSL

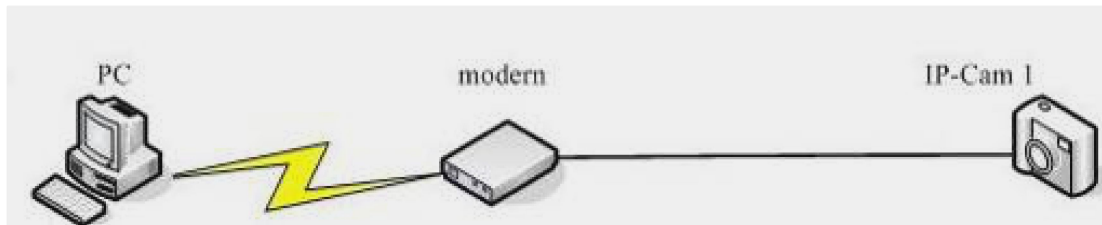

Figure 3.23

If you are connecting the camera directly to a ADSL modem, you can do ADSL settings with your ADSL account & password provided by the ISP, then make the camera connected to the network.

The screenshot shows the FOSCAM web interface for an Indoor Pan/Tilt IP Camera. The left sidebar contains a menu with various settings options. The main content area is titled 'ADSL Settings' and includes a checkbox for 'Using ADSL Dialup' (checked), an 'ADSL User' field containing 'SZ10752487966341', and an 'ADSL Password' field with masked characters. Below these fields are 'Submit' and 'Refresh' buttons. A red box highlights the user and password fields, with a red arrow pointing to a red-bordered callout box that says 'Enter the ADSL user and password.'

Figure 3.24

3.9 UPnP Settings

The screenshot shows the FOSCAM web interface for an Indoor Pan/Tilt IP Camera. The left sidebar contains a menu with various settings options. The main content area is titled 'UPnP Settings' and includes a checkbox for 'Using UPnP to Map Port' (checked). Below this checkbox are 'Submit' and 'Refresh' buttons.

Figure 3.25

The default UPnP status is closed. You can select the check box and open UPnP, then the camera's software will be configured for port forwarding. Back to the "Device Status" panel, you can see the UPnP status:

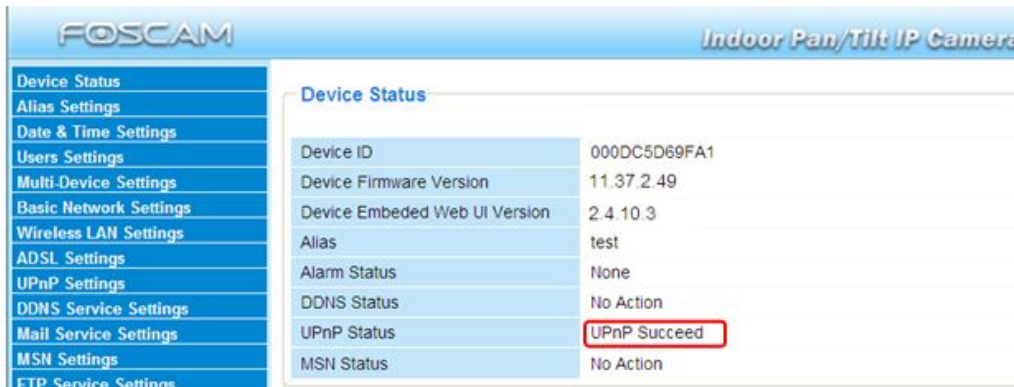

There may be issues with your routers security settings, and sometimes may error. We recommend you configure port forwarding manually on your router (Figure 3.30).

3.10 DDNS Service Settings

FOSCAM camera has embedded a unique DDNS domain name when producing, and you can directly use the domain name, you can also use the third party domain name.

FOSCAM domain name

Here take camera.myfoscam.org for example. Go to option of **DDNS Service Settings** on the administrator panel, you can see the domain name.

Please **enable** the FOSCAM DDNS name first.

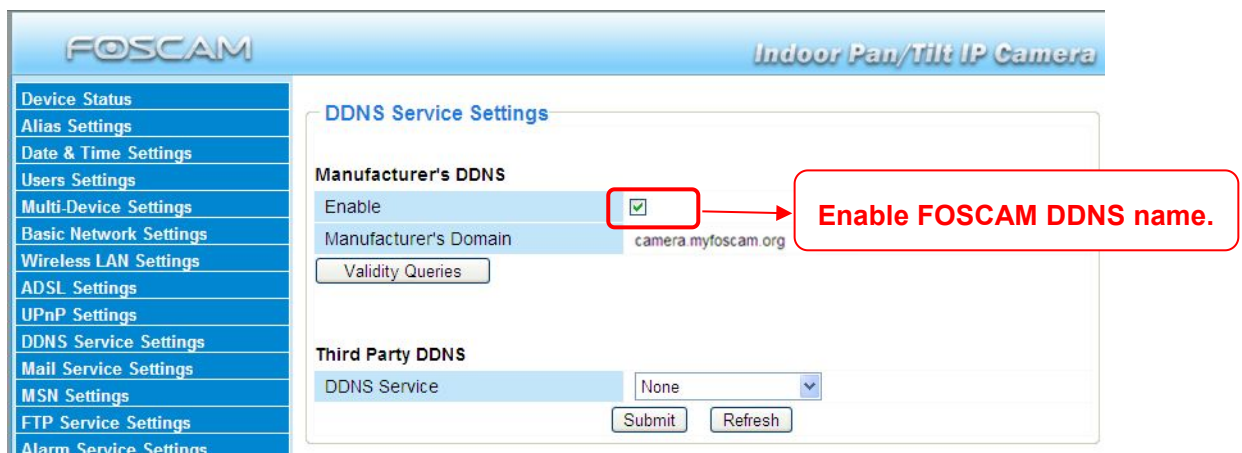

Figure 3.26

Enable: Open or close the FOSCAM domain name. The default status of FOSCAM domain name is open.

Validity Queries: Check the validity of embedded domain name.

Now you can use [http:// Domain name + HTTP Port](http://Domain name + HTTP Port) to access the camera via internet.

Take hostname camera.myfoscam.org and **HTTP Port no. 88** for example, the accessing link of the camera via internet would be [http:// camera.myfoscam.org:88](http://camera.myfoscam.org:88)

Note: If you want to use the manufacturer's domain name, please select None as the Third Party DDNS and enable the Manufacturer's domain name, then click submit.

Third Party Domain Name Settings

User can also use third part DDNS, such as www.no-ip.com , www.dyndns.com

Here take www.no-ip.com for example:

Step 1, Go to the website www.no-ip.com to create a free hostname

Firstly: Login on www.no-ip.com and click No-IP Free to register.



Figure 3.27

Please register an account step by step according to instructions on www.no-ip.com

After registration, please login your email which used to register. You will receive an email from website, please click the link to activate your ACCOUNT as indicated in email.

Secondly: Login the link with the registered username and password to create your domain name.

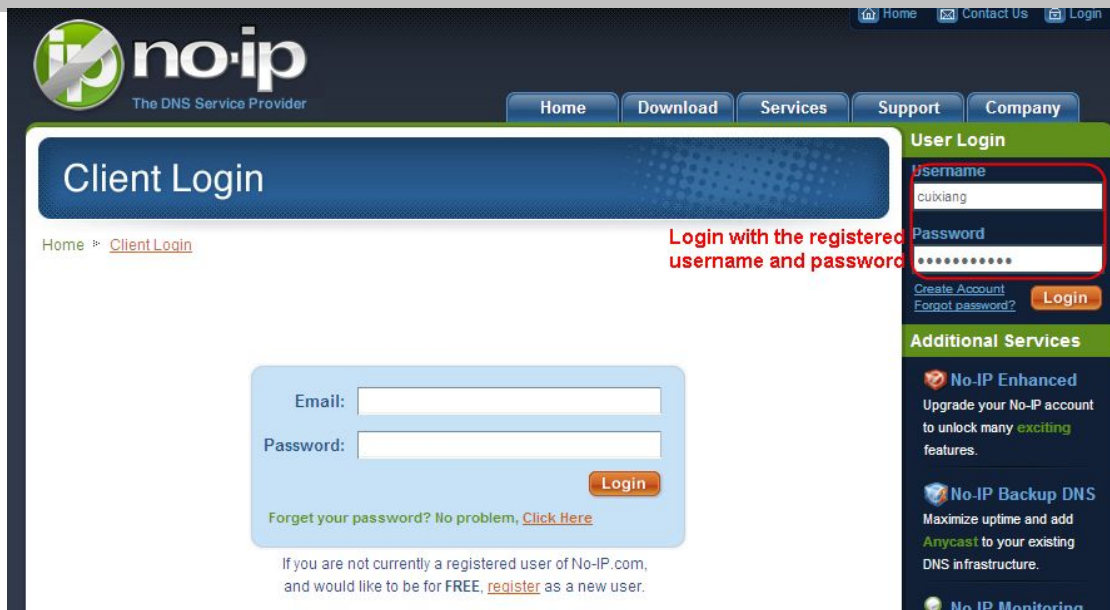

Figure 3.28

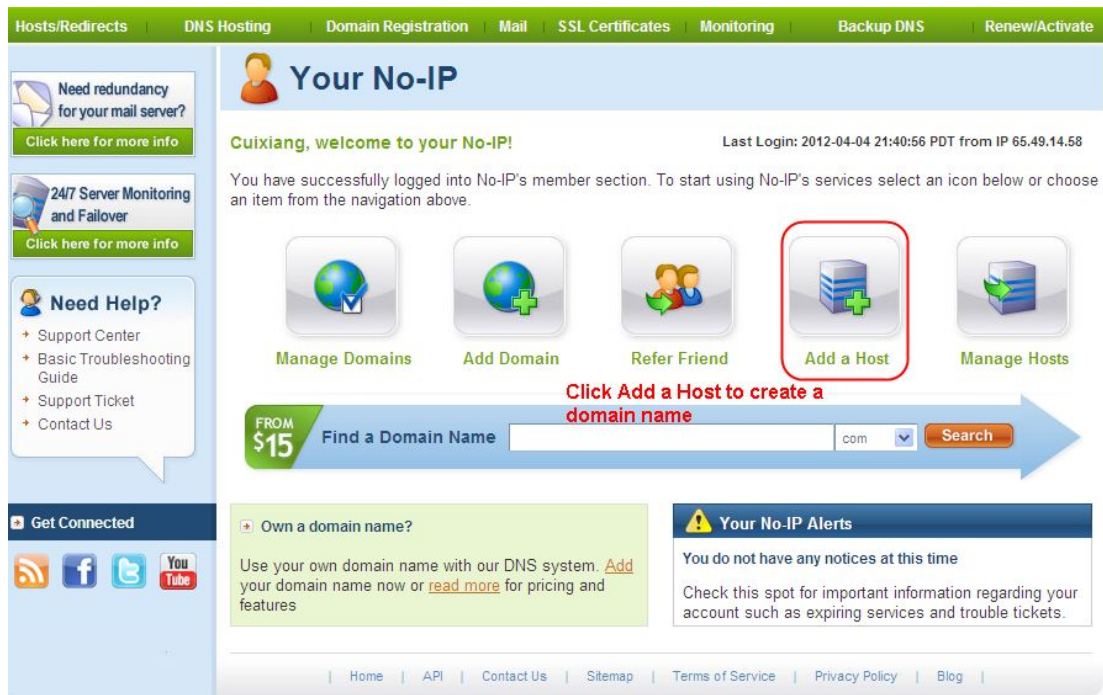

Figure 3.29

Please create the domain name step by step according to instructions on www.no-ip.com

Step 2, DO DDNS Service Settings within the Camera

Please set **DDNS Service Settings** within the camera by **hostname**, a **user name** and **password** you've got from www.no-ip.com

Take **hostname** ycxgwp.no-ip.info, **user name** foscam, **password** foscam2012 for example.

Firstly, goes to option of **DDNS Service Settings** on the administrator panel.

Secondly, disable the Manufacturer's domain name and select No-ip as a server in the **Third**

Party DDNS.

Thirdly, fill **foscam** as DDNS user, fill password **foscam2012** as DDNS password, fill **ycxgwp.no-ip.info** as DDNS domain and server URL, Then click save to make effect. The camera will restart and to take the DDNS settings effective.

Fourthly, after the restart, login the camera, and go to option of **Device Status** on the administrator panel, and check if the DDNS status is successful.

If failed, please double check if you have input the correct hostname, user name, and password, and try to redo the settings.

NOTE:

The Third Party DDNS and the Manufacturer's Domain Name cannot work at the same time. If you have set Third Party DDNS and meanwhile you enabled the Foscam Domain Name, the Third Party DDNS will take effect.

② Do port forwarding within the router

Example: The camera's LAN IP address is <http://192.168.1.35>,

Firstly, login the router, goes to the menu of **Port Forwarding** or **Port Trigger** (or named **Virtue Server** on some brands of router). Take **Linksys** brand router as an example, **Login the router, and goes to Applications & Gaming->Single Port Forwarding**

Secondly, Create a new column by LAN IP address & HTTP Port No. of the camera within the router showed as below.

The screenshot shows the Linksys router's 'Single Port Forwarding' configuration page. The page has a blue header with the Linksys logo and 'by Cisco'. Below the header, there are navigation tabs for 'Setup', 'Wireless', 'Security', 'Access Restrictions', 'Applications & Gaming', 'Administration', and 'Status'. Under 'Applications & Gaming', there are sub-tabs for 'Single Port Forwarding', 'Port Range Forwarding', 'Port Range Triggering', 'DMZ', and 'QoS'. The 'Single Port Forwarding' sub-tab is selected, and it shows a table with the following columns: 'External Port', 'Internal Port', 'Protocol', 'To IP Address', and 'Enabled'. There are five rows in the table. The first four rows have '---' in the 'External Port' and 'Internal Port' columns, and '192.168.1.' in the 'To IP Address' column. The fifth row has '88' in the 'External Port' and 'Internal Port' columns, 'Both' in the 'Protocol' column, '192.168.1.35' in the 'To IP Address' column, and a checked checkbox in the 'Enabled' column. Red boxes and arrows highlight these fields with instructions: 'Assign a name as you like here' (pointing to the 'Application Name' dropdown), 'fill the port no. 88 of the camera on the column of External and Internal Port', and 'Fill the LAN IP of the camera here, just input the last section 35.'

Figure 3.30

③ Use domain name to access the camera via internet

After the port forwarding is finished, you can use the domain name+ http no. to access the camera via internet. Take hostname ycxgwp.no-ip.info and http no. 88 for example, the accessing link of the camera via internet would be [http:// ycxgwp.no-ip.info:88](http://ycxgwp.no-ip.info:88)

3.11 Mail Service Settings

If you want the camera to send emails when motion/sound has been detected, **Mail Service Settings** will need to be configured.

Figure 3.31

- 1----- **Sender** Mailbox for sender must support SMTP
- 2----- **Receiver** Mailbox for receiver need not support SMTP, you can set 4 receivers
- 3----- **SMTP Server/ Port** Enter SMTP server for sender. **SMTP port** is usually set as 25. Some SMTP servers have their own port, such as 587 or 465 and Transport Layer Security usually is None. If you use Gmail, Transport Layer Security must be set to TLS or STARTTLS and SMTP Port must be set to 465 or 25 or 587, which port you choose should be decided by which Transport Layer Security you select.
- 4----- **SMTP user** ID account of the sender email address
- 5----- **Submit** Click Submit to take effect
- 6----- **Test** Click **Test** to see if SMTP has been successfully configured.

NOTE: Click **Submit** first before choosing **Test**.

Click **Test** to see if SMTP has been successfully configured.

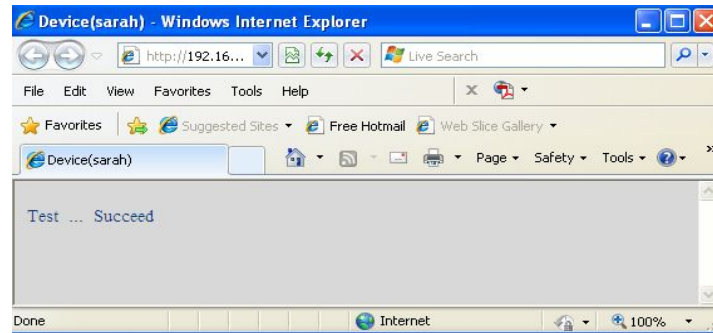

Figure 3.32

If the test fails with one of the following errors after clicking **Test**, **verify** that the information you entered is correct and again select **Test**.

- 1) Cannot connect to the server
- 2) Network Error. Please try later
- 3) Server Error
- 4) Incorrect user or password
- 5) The sender is denied by the server. Maybe the server need to authenticate the user, please check it and try again
- 6) The receiver is denied by the server. Maybe because of the anti-spam privacy of the server
- 7) The message is denied by the server. Maybe because of the anti-spam privacy of the server
- 8) The server does not support the authentication mode used by the device

Report Internet IP by Mail—If selected, you will receive emails which contains internet IP information such as When the camera is powered or the Internet IP has changed. (For example: IPCAM's urls is <http://119.123.207.96:8068>). Make sure the port is mapped to the router correctly.

3.12 MSN Setting

If you want the camera send its current internet IP address to you or your friends, please set MSN settings.

Acquire an MSN ID for the IPCAM first, then follow the instructions as per Figure 3.33.

FOSCAM Indoor Pan/Tilt IP Camera

MSN Settings

User: fosc31@hotmail.com

Password:

MSN Friends List:

- fosc13@hotmail.com
- sanshao27@hotmail.com
-
-
-
-
-
-
-
-

Submit Refresh

Fill in the user and password of the MSN ID you applied for your camera.

MSN ID in this list can chat with the camera.

Figure 3.33

Click Submit and go to the “Device Status” screen and verify the MSN settings are succeed.

FOSCAM Indoor Pan/Tilt IP Camera

Device Status

Device ID	000000000000A
Device Firmware Version	11.37.2.49
Device Embedded Web UI Version	2.4.10.3
Alias	apple
Alarm Status	None
DDNS Status	Foscam Succeed http://camera.myfoscam.org 85
UPnP Status	No Action
MSN Status	Succeed

Figure 3.34

When the MSN ID in the Friends list login the MAN, he can chat with camera. For example: Fosc313(this account contained in the Friends list) log in MSN, and double click the camera’s account (fosc31), then enter “url?”, the camera will send it’s current IP address to you.

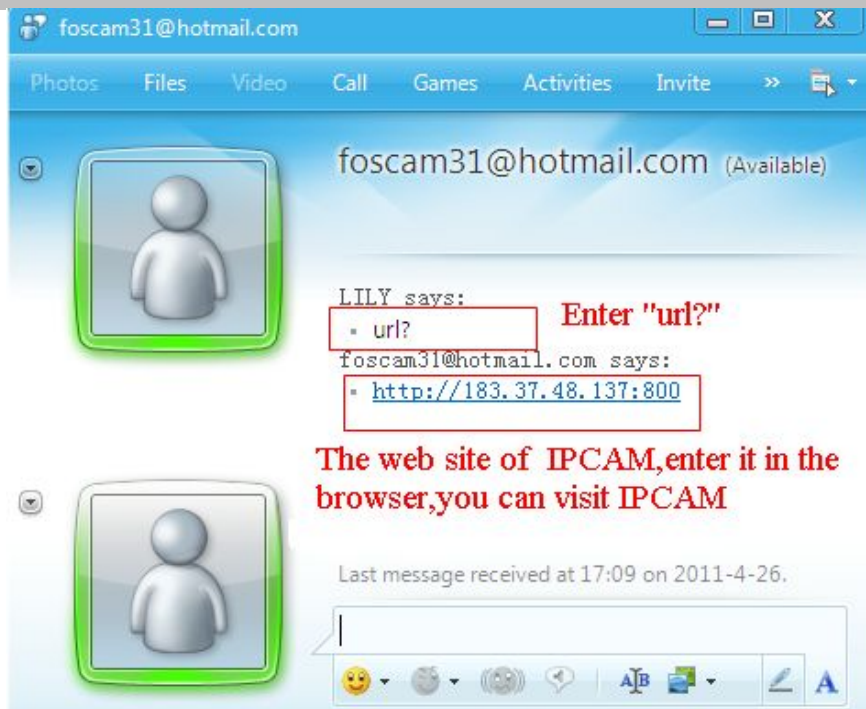

Figure 3.35

Note: Create a new MSN account for the camera, do not use the same MSN account as you would like to chat with your friends. When the camera login uses the MSN account, this account cannot be used for anything else when the camera works.

3.13 FTP Service Settings

If you want to upload images to your FTP server, you can set **FTP Service Settings**.

FTP Service Settings	
FTP Server	192.168.0.50
FTP Port	21
FTP User	sarah
FTP Password	••••
FTP Upload Folder	/
FTP Mode	PORT
	Test Please set first, and then test.
Upload Image Now	<input checked="" type="checkbox"/>
Upload Interval (Seconds)	30
Enable Set Filename	<input checked="" type="checkbox"/>
Filename	sarah
	Submit Refresh

Figure 3.36

FTP Service Settings	
FTP Server	ftp.mgenseal.com
FTP Port	21
FTP User	deotest@mgenseal.com
FTP Password	••••
FTP Upload Folder	/
FTP Mode	PORT
	<input type="button" value="Test"/> Please set first, and then test.
Upload Image Now	<input checked="" type="checkbox"/>
Upload Interval (Seconds)	30
Enable Set Filename	<input checked="" type="checkbox"/>
Filename	sarah
<input type="button" value="Submit"/> <input type="button" value="Refresh"/>	

Figure 3.37

FTP server: If your FTP server is located on the LAN, you can set as Figure 3.36.

If you have an FTP server which you can access on the internet, you can set as Figure 3.37.

FTP Port: Usually the port is 21.

FTP Upload Folder: Make sure that the folder you plan to store images exists as the camera can't create the folder itself. Also, the folder must be read/writable.

FTP Mode: The camera supports standard (POST) mode and passive (PASV) mode

Upload Image Now: This option will upload images continuously when you enable the checkbox

Enable Set Filename: When you enable this option the uploaded image will be named according to the filename you enter. The next image will overwrite the filename of the previous image. Hence there will only be one image, the last uploaded.

Filename: See the above option.

Note: You cannot change the name of the alarm image.

Upload Interval refers to the time between the current image and the next image being uploaded.

Click **Submit** to save these settings. Click **Test**, the following screen displays if successful.

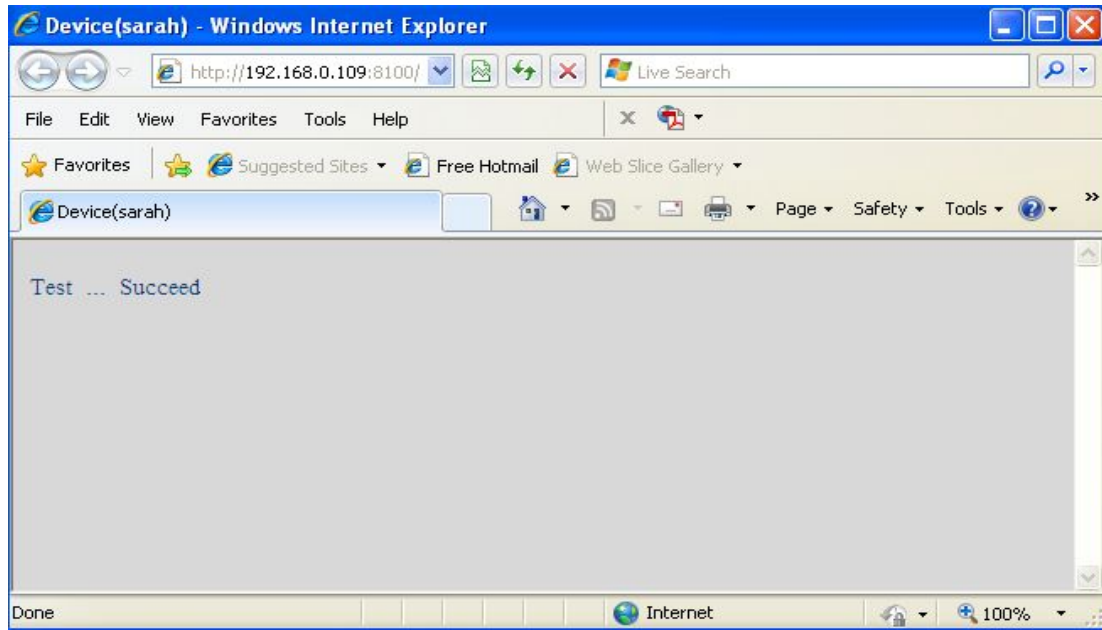

Figure 3.38

The following errors may occur:

- 1) Can not connect to the server. Check if the FTP Server is correct.
- 2) Network Error. Please try later.
- 3) Server Error.
- 4) Incorrect user or password. Check the username and password.
- 5) Cannot access the folder. Verify the folder exists and your account is authorized
- 6) Error in PASV mode. Verify the server supports PASV mode.
- 7) Error in PORT mode. PASV mode should be selected if the device is behind a NAT.
- 8) Cannot upload file. Verify your account is authorized

If an error occurs check the parameters you entered are correct. The filename format of the image is similar to 00606E8C1930(sarah)_0_20100728114350_25.jpg

Check if your FTP server supports this file name format.

3.14 Alarm Service Settings

IP Camera supports **Motion Detection Alarmed** and **Sound Detection Alarmed**, when the motion or sound has been detected, it will send email alerts or upload images or record.

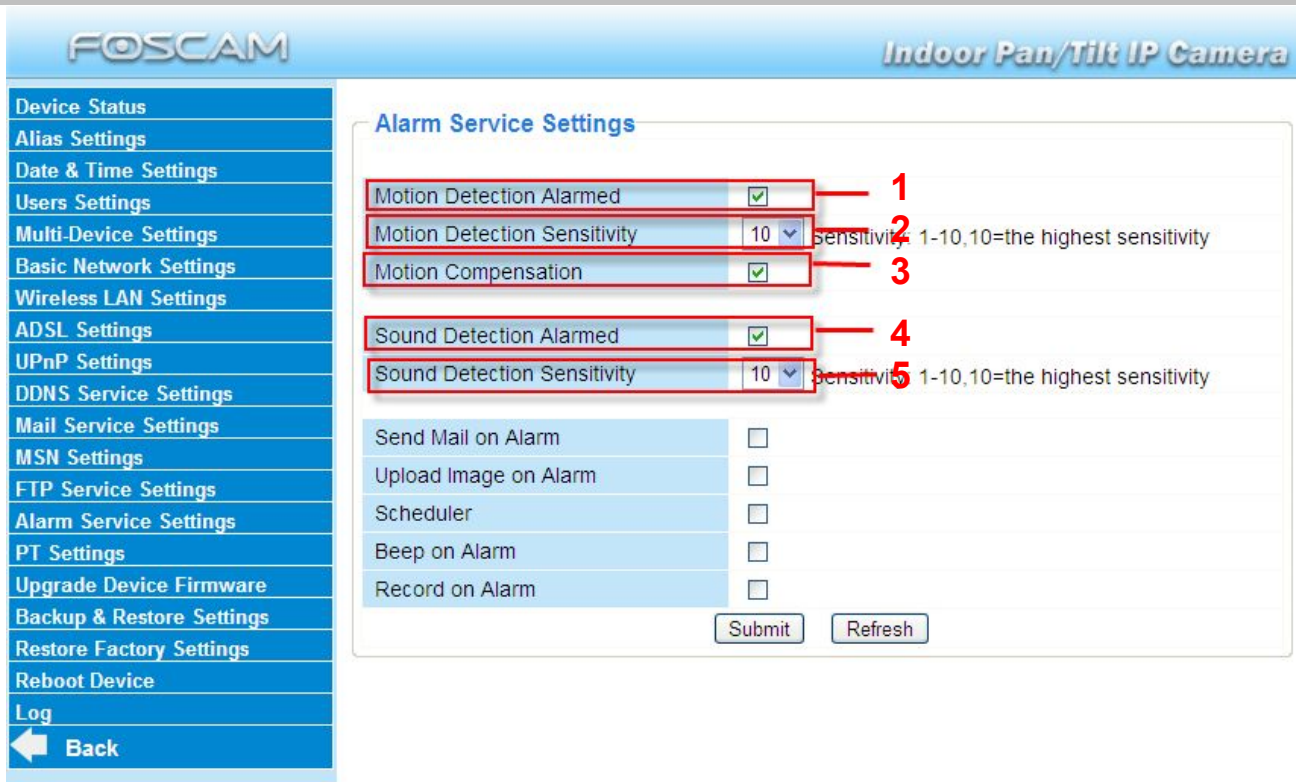

Figure 3.39

1---- If you want to set Motion Detection Alarmed ,select the checkbox

2---- The larger the number, the higher the motion sensitivity will be

3---- Select this option to reduce false alarms when light changes

4---- If you want to do Sound Detection Alarmed,select the checkbox

5---- The larger the number, the higher the sound sensitivity will be

If motion/sound is detected after you enable **Motion Detection Armed/Sound Detection Alarmed**, the Alarm Status will turn to Motion/Sound Detect Alarm.

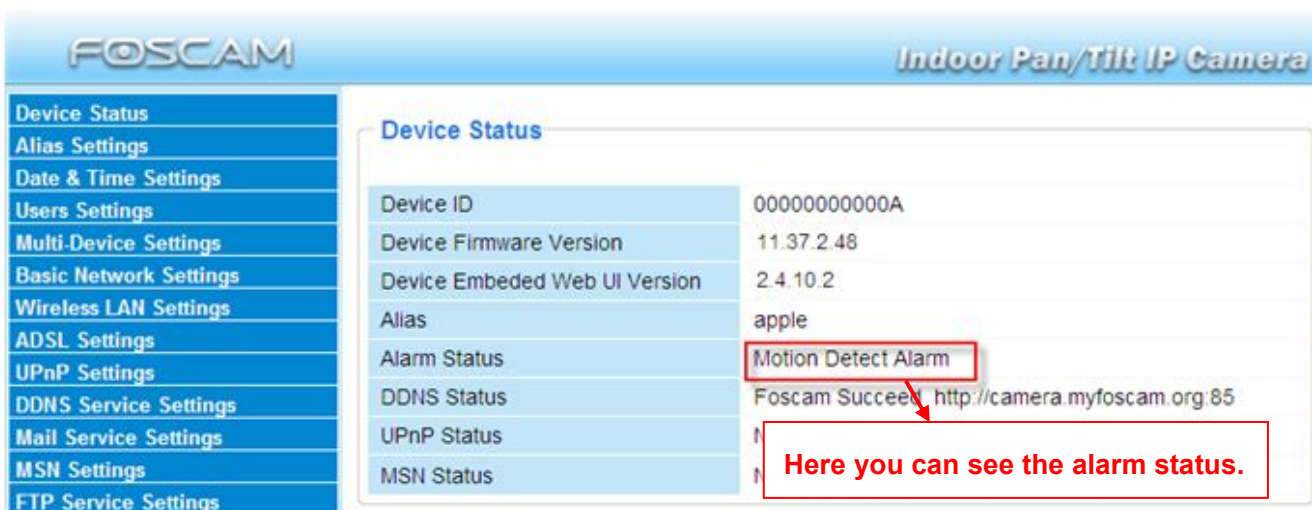

Figure 3.40

There are four alarm indicators:

1) Camera will send emails when motion/sound is activated.

If you want to receive images when motion is detected, you must set **Mail Service Settings** first. (Figure 3.31) Then set motion alarm as follows:

Alarm Service Settings	
Motion Detection Alarmed	<input checked="" type="checkbox"/>
Motion Detection Sensitivity	10 <small>Sensitivity: 1-10,10=the highest sensitivity</small>
Motion Compensation	<input checked="" type="checkbox"/>
Sound Detection Alarmed	<input checked="" type="checkbox"/>
Sound Detection Sensitivity	10 <small>Sensitivity: 1-10,10=the highest sensitivity</small>
Send Mail on Alarm	<input checked="" type="checkbox"/>
Upload Image on Alarm	<input type="checkbox"/>
Scheduler	<input type="checkbox"/>
Sound on Alarm	<input type="checkbox"/>
Record on Alarm	<input type="checkbox"/>

Submit Refresh

Figure 3.41

2) Upload images via FTP server when motion/sound trigger.

To upload images to an FTP server when motion/sound is detected, you must set **FTP Service Settings**(Figure 3.36/3.37) first and then set motion/sound alarm as pictured below

Alarm Service Settings	
Motion Detection Alarmed	<input checked="" type="checkbox"/>
Motion Detection Sensitivity	10 <small>Sensitivity: 1-10,10=the highest sensitivity</small>
Motion Compensation	<input checked="" type="checkbox"/>
Sound Detection Alarmed	<input checked="" type="checkbox"/>
Sound Detection Sensitivity	10 <small>Sensitivity: 1-10,10=the highest sensitivity</small>
Send Mail on Alarm	<input checked="" type="checkbox"/>
Upload Image on Alarm	<input checked="" type="checkbox"/>
Upload Interval (Seconds)	30
Scheduler	<input type="checkbox"/>
Sound on Alarm	<input type="checkbox"/>
Record on Alarm	<input type="checkbox"/>

Submit Refresh

Figure 3.42

3) You can hear the beep sound when the alarm has been detected.

Alarm Service Settings

Motion Detection Alarmed	<input checked="" type="checkbox"/>	
Motion Detection Sensitivity	10	Sensitivity: 1-10,10=the highest sensitivity
Motion Compensation	<input checked="" type="checkbox"/>	
Sound Detection Alarmed	<input checked="" type="checkbox"/>	
Sound Detection Sensitivity	10	Sensitivity: 1-10,10=the highest sensitivity
Send Mail on Alarm	<input checked="" type="checkbox"/>	
Upload Image on Alarm	<input checked="" type="checkbox"/>	
Upload Interval (Seconds)	30	
Scheduler	<input type="checkbox"/>	
Sound on Alarm	<input checked="" type="checkbox"/>	
Record on Alarm	<input type="checkbox"/>	

Submit Refresh

Select this option.

Figure 3.43

4) The camera will record automatically for one minute after motion/sound is detected.

You can find the recording file in the folder which you set previously. (Figure 3.6)

Alarm Service Settings

Motion Detection Alarmed	<input checked="" type="checkbox"/>	
Motion Detection Sensitivity	10	Sensitivity: 1-10,10=the highest sensitivity
Motion Compensation	<input checked="" type="checkbox"/>	
Sound Detection Alarmed	<input checked="" type="checkbox"/>	
Sound Detection Sensitivity	10	Sensitivity: 1-10,10=the highest sensitivity
Send Mail on Alarm	<input checked="" type="checkbox"/>	
Upload Image on Alarm	<input checked="" type="checkbox"/>	
Upload Interval (Seconds)	30	
Scheduler	<input type="checkbox"/>	
Sound on Alarm	<input checked="" type="checkbox"/>	
Record on Alarm	<input checked="" type="checkbox"/>	
Alarm Record Filepop	<input checked="" type="checkbox"/>	

Submit Refresh

Select the checkbox

When you enable motion alarm, the camera will record automatically and store the recording file to the folder you configured. This icon is used to control whether the folder opens or not.

Figure 3.44

Alarm Scheduler:

Here are two ways to set the alarm.

1) Alarm at any time when motion/sound is detected.

Don't select **Scheduler**. Click Submit and the camera will alarm at any time when motion is detected.

Alarm Service Settings

Motion Detection Alarmed	<input checked="" type="checkbox"/>
Motion Detection Sensitivity	10 <small>Sensitivity: 1-10,10=the highest sensitivity</small>
Motion Compensation	<input checked="" type="checkbox"/>
Sound Detection Alarmed	<input checked="" type="checkbox"/>
Sound Detection Sensitivity	10 <small>Sensitivity: 1-10,10=the highest sensitivity</small>
Send Mail on Alarm	<input type="checkbox"/>
Upload Image on Alarm	<input type="checkbox"/>
Scheduler	<input type="checkbox"/>
Sound on Alarm	<input type="checkbox"/>
Record on Alarm	<input type="checkbox"/>

Submit Refresh

Figure 3.45

Another Way: select Scheduler, and click "set All", you will see all time boxes turn blue as in the following picture. Click Submit and the camera will alarm at any time when motion is detected.

FOSCAM Indoor Pan/Tilt IP Camera

Sound Detection Sensitivity: 10 Sensitivity: 1-10,10=the highest sensitivity

Send Mail on Alarm:

Upload Image on Alarm:

Upload Interval (Seconds): 30

Scheduler:

Beep on Alarm:

Record on Alarm:

Alarm Record Filepop:

set All clear All

Set	00	01	02	03	04	05	06	07	08	09	10	11	12	13	14	15	16	17	18	19	20	21	22	23
Clear	00	01	02	03	04	05	06	07	08	09	10	11	12	13	14	15	16	17	18	19	20	21	22	23
Day	0	1	2	3	4	5	6	7	8	9	10	11	12	13	14	15	16	17	18	19	20	21	22	23
Sun	[Blue Grid]																							
Mon	[Blue Grid]																							
Tue	[Blue Grid]																							
Wed	[Blue Grid]																							
Thu	[Blue Grid]																							
Fri	[Blue Grid]																							
Sat	[Blue Grid]																							

Submit Refresh

Figure 3.46

2) Specify an alarm schedule.

If you want the camera to alarm during set times select **Scheduler** and set time range.

If you want to select one serial area, you can click any number between 00 and 23 on the first row, the corresponding column will be selected and it will turn blue. For example, click the number "06" on the first row, you can see the column turn blue. That means the camera will alarm when motion/sound is detected between 6 and 7 o'clock every day. Click the number "06" on the second row, you can cancel the corresponding column you set. And it will turn grey.

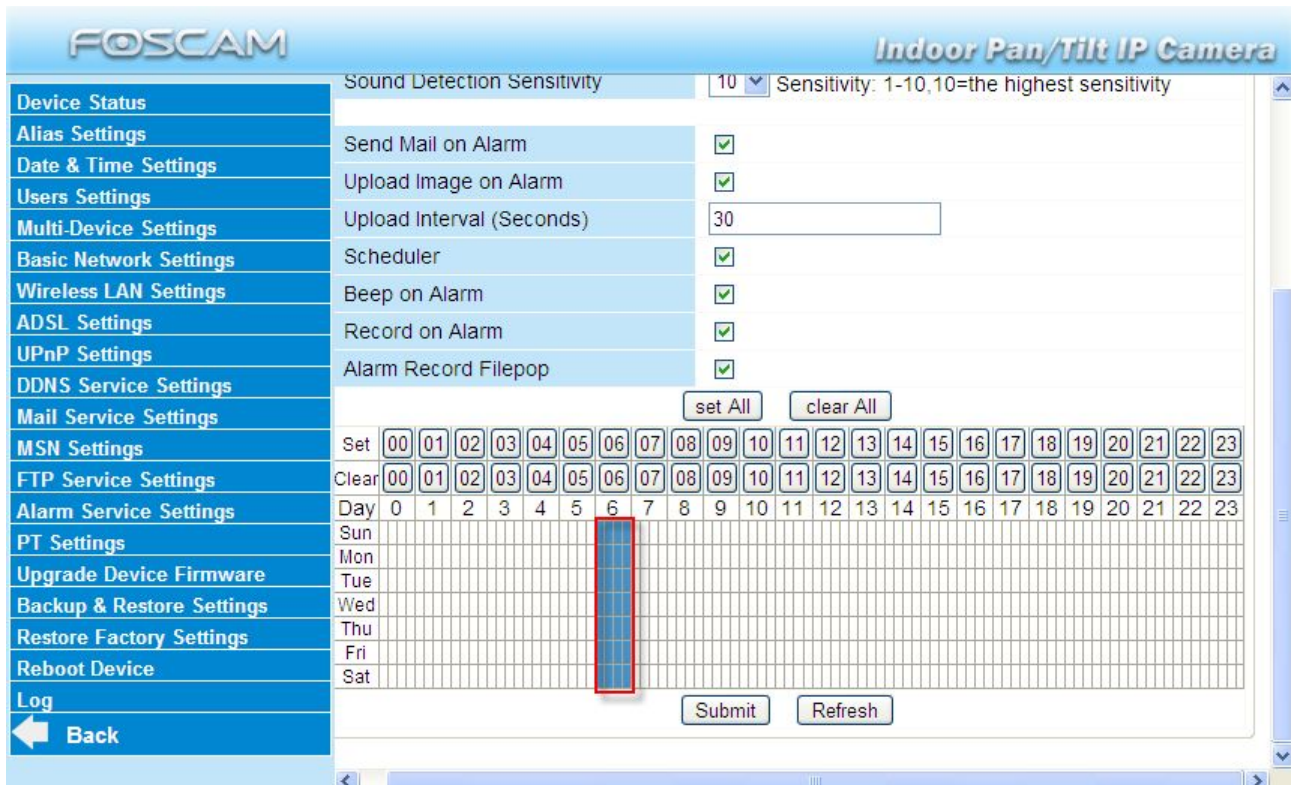

Figure 3.47

If you want to select discrete area, you click the left button on the box of time range. It will turn blue. If you want to delete it, just click the left button and it will turn grey.

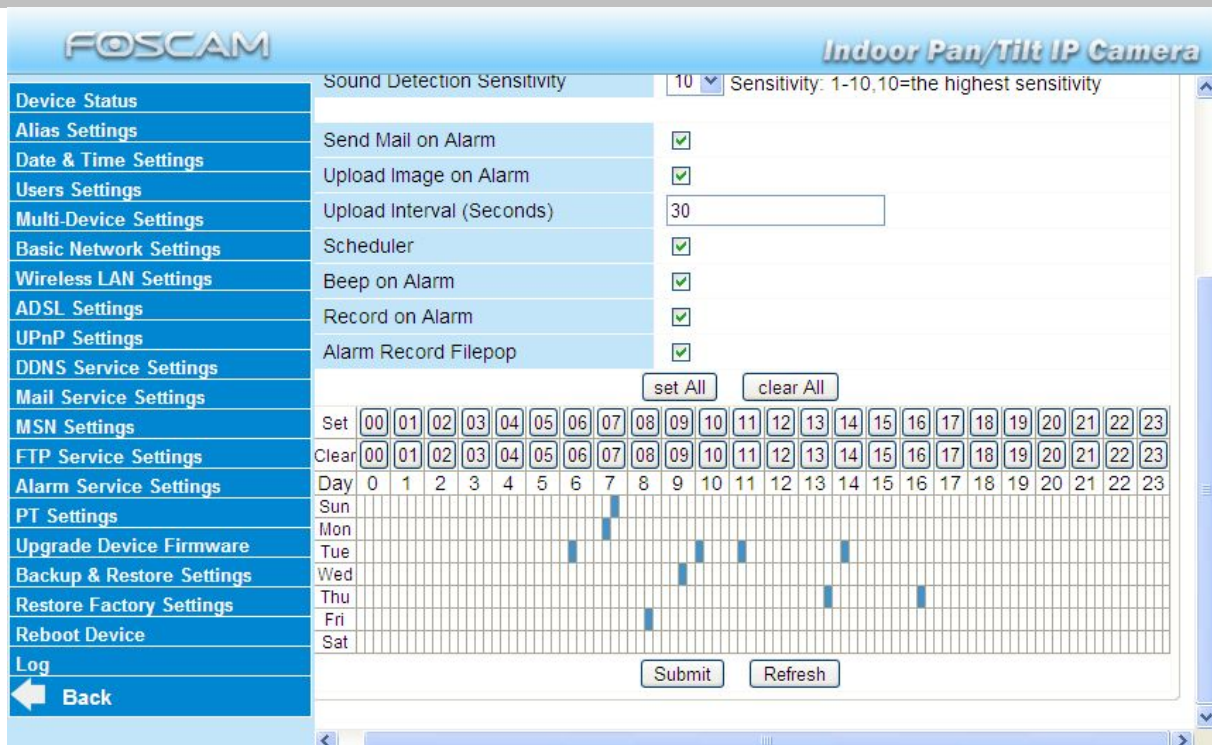

Figure 3.48

3.15 PT Settings

You can set pan/tilt speed. Normally, PT speed is 3. The larger the setting number, the lower speed. Don't enable the checkbox "disable preset" if you want to use the function of preset, it will be effective after you reboot device.

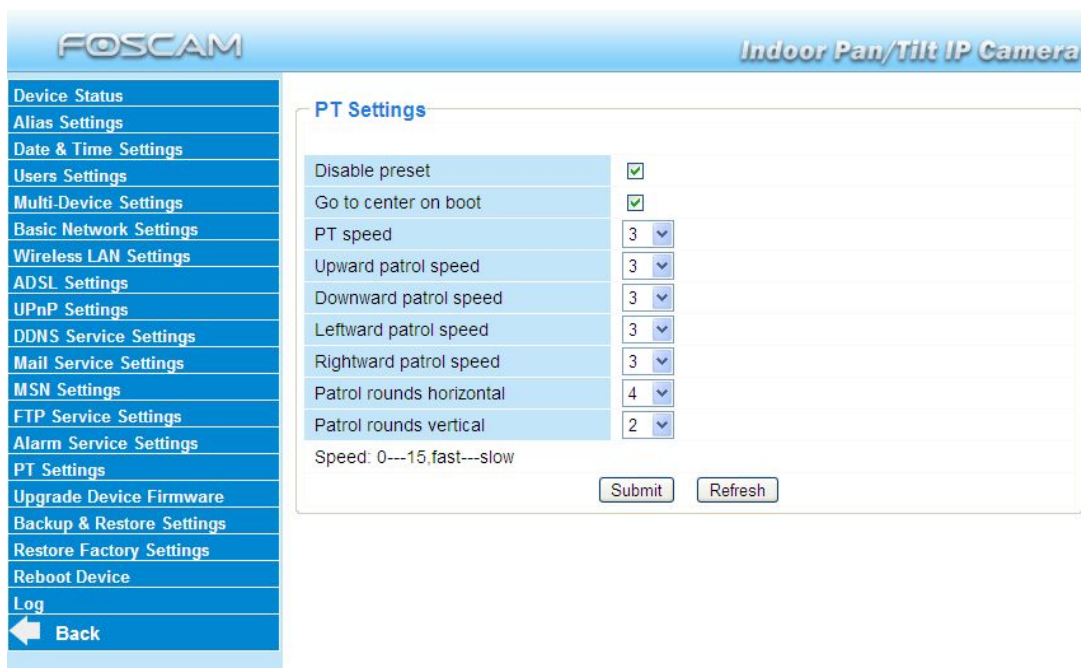

Figure 3.49

Patrol rounds horizontal: Set the round between 1 and 10, then click Submit. Back to surveillance window. Click the Horizon patrol button, the camera will patrol the rounds horizontally you set and then stop if you don't click Stop horizon patrol button. For example, you set 4 for the patrol rounds. Click submit and back to surveillance window. Click the Horizon patrol button and do not click the Stop horizon patrol button, the camera will patrol 4 rounds and then stop automatically.

Patrol rounds vertical: Set the round between 1 and 10, then click submit. Back to surveillance window Click the Vertical patrol button, the camera will patrol the rounds vertically you set and then stop if you don't click Stop vertical patrol button.

3.16 Upgrade Device Firmware

When you upgrade the camera, please upgrade system firmware first and then upgrade the Web UI.

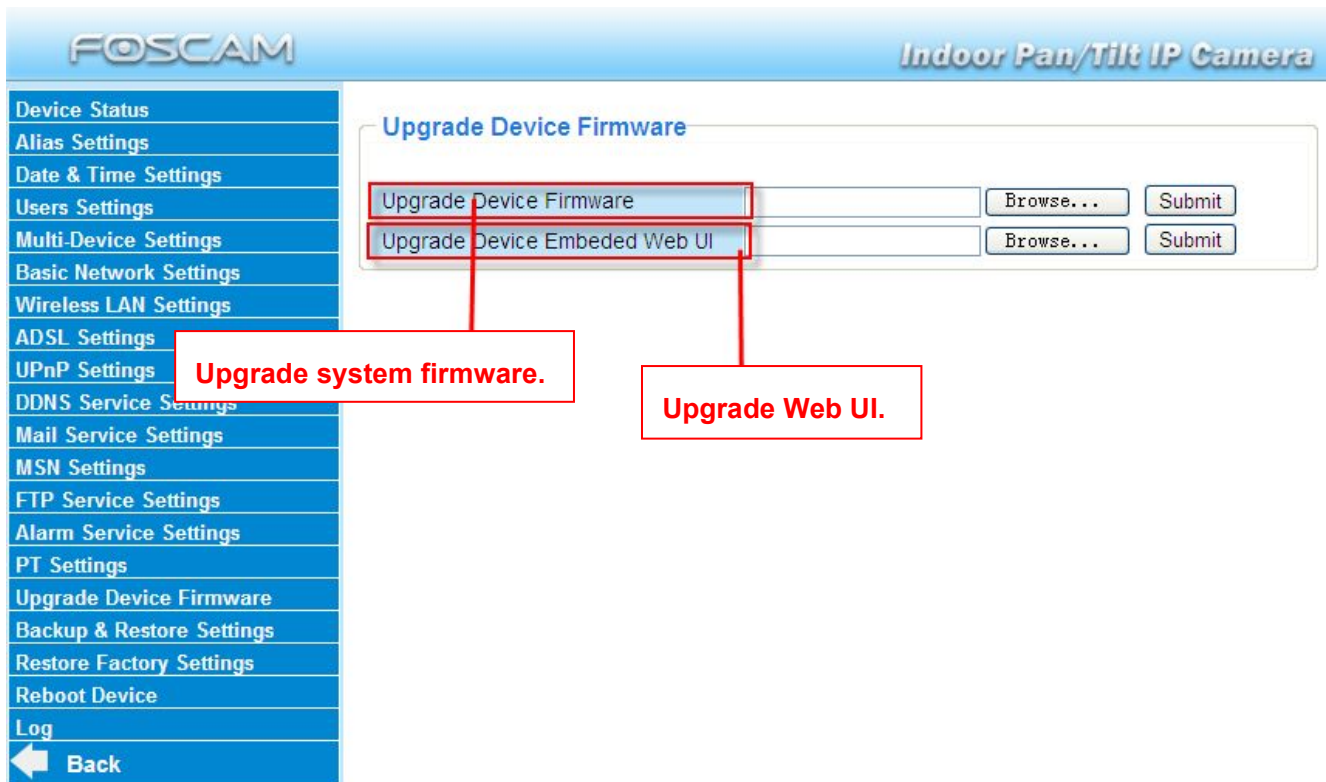

Figure 3.50

Click **Browse**, choose the correct bin file and then click **Submit** to upgrade.

Don't shut down the power during upgrade until the IP camera tool finds the camera again.

Upgrade Firmware by IP Camera Tool

Double click the IP Camera Tool shot icon , select the Camera IP that you want to upgrade the firmware. Then select Upgrade Firmware and enter the username and password, choose the firmware file, and upgrade.

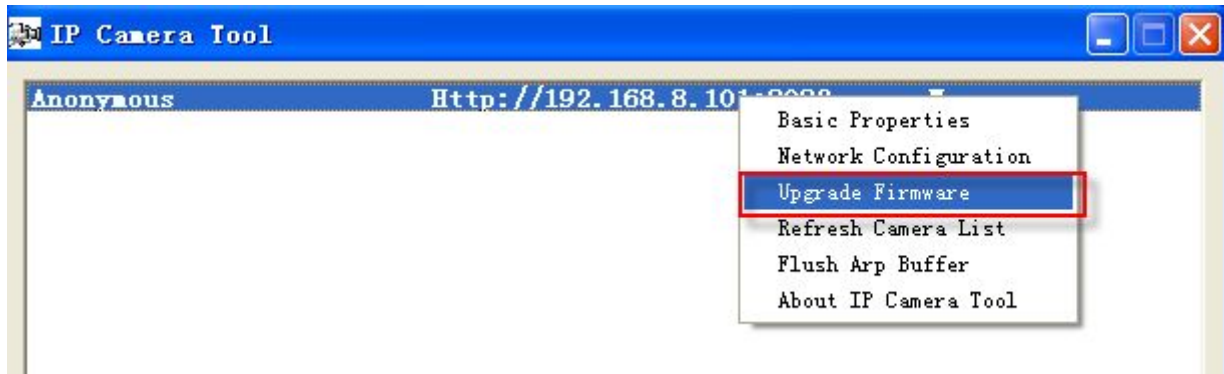

Figure 3.51

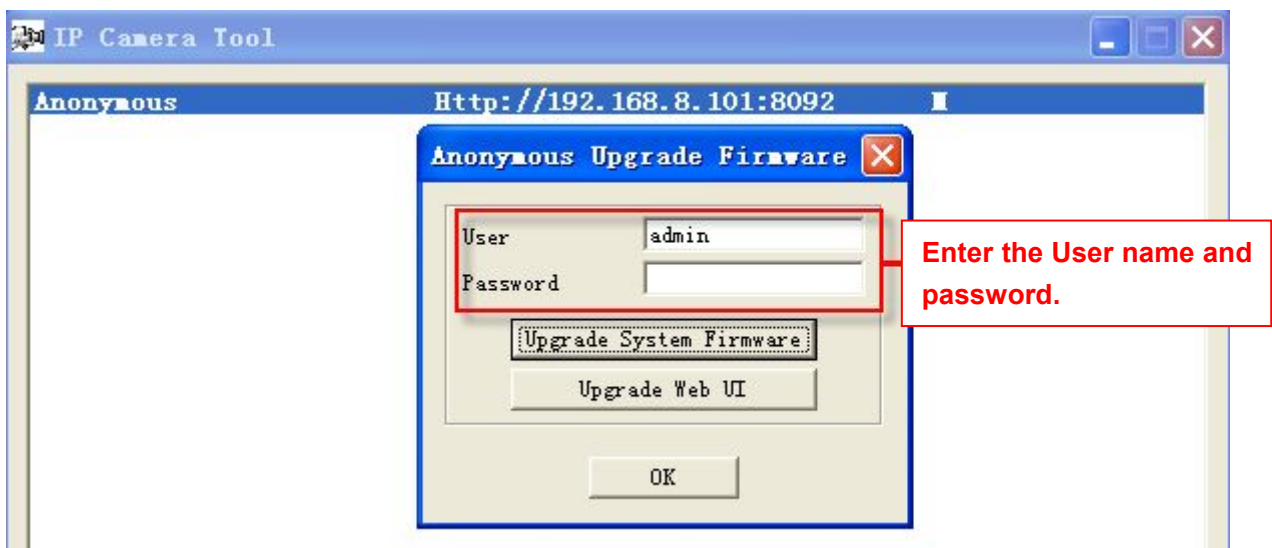

Figure 3.52

CAUTION: If your camera works well with the current firmware, we recommend not upgrading. Please don't upgrade the firmware unnecessarily. Your camera may be damaged if misconfigured during an upgrade.

NOTE:

- 1) Please ensure you have downloaded the correct firmware package for your camera before upgrading. Read the upgrade documentation (readme.txt file) in the upgrade package before you upgrade.
- 2) Upon downloading the firmware check the sizes of the .bin files. They must match the size in the readme.txt file. If not, please download the firmware again until the sizes are the same. Your

camera will not function correctly if a corrupt .bin file is used.

3) Normally, only Device WEB UI need to be upgrade, please do not try to upgrade the Device Firmware.

4) Never shut down the power of the camera during upgrade until the IP camera restart and get connected.

3.17 Backup & Restore Settings

Click **Submit** to save all the parameters you have set. These parameters will be stored in a bin file for future use. The bin file can be reloaded to restore the parameters that were set.

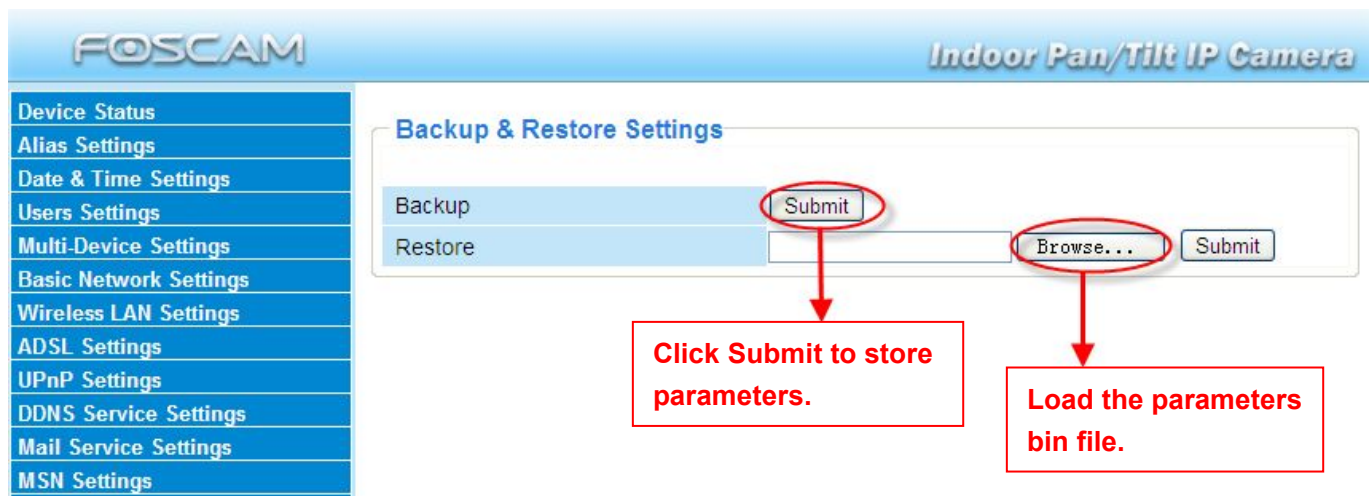

Figure 3.53

3.18 Restore Factory Settings

All parameters will return to factory settings if selected.

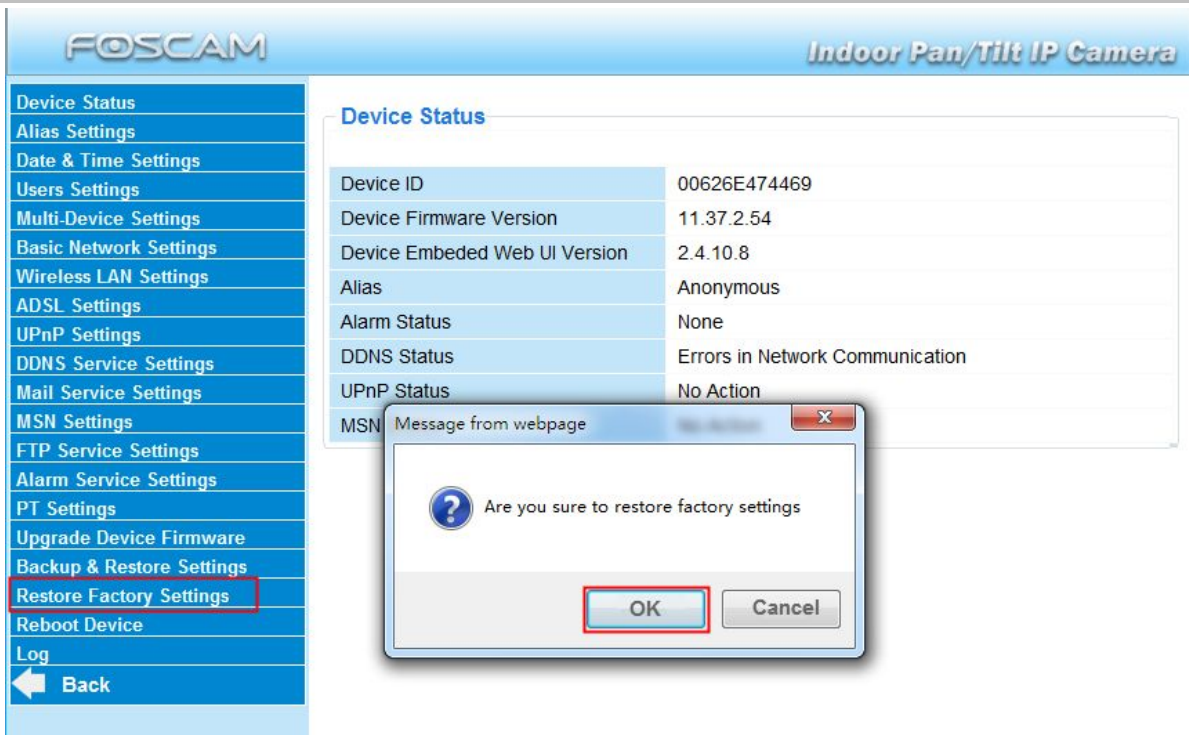

Figure 3.54

3.19 Reboot Device

Click **Reboot Device** to reboot the camera. This is similar to unplugging the power to the camera.

3.20 Log

The log record shows who accessed the camera and when. (Figure 3.55).

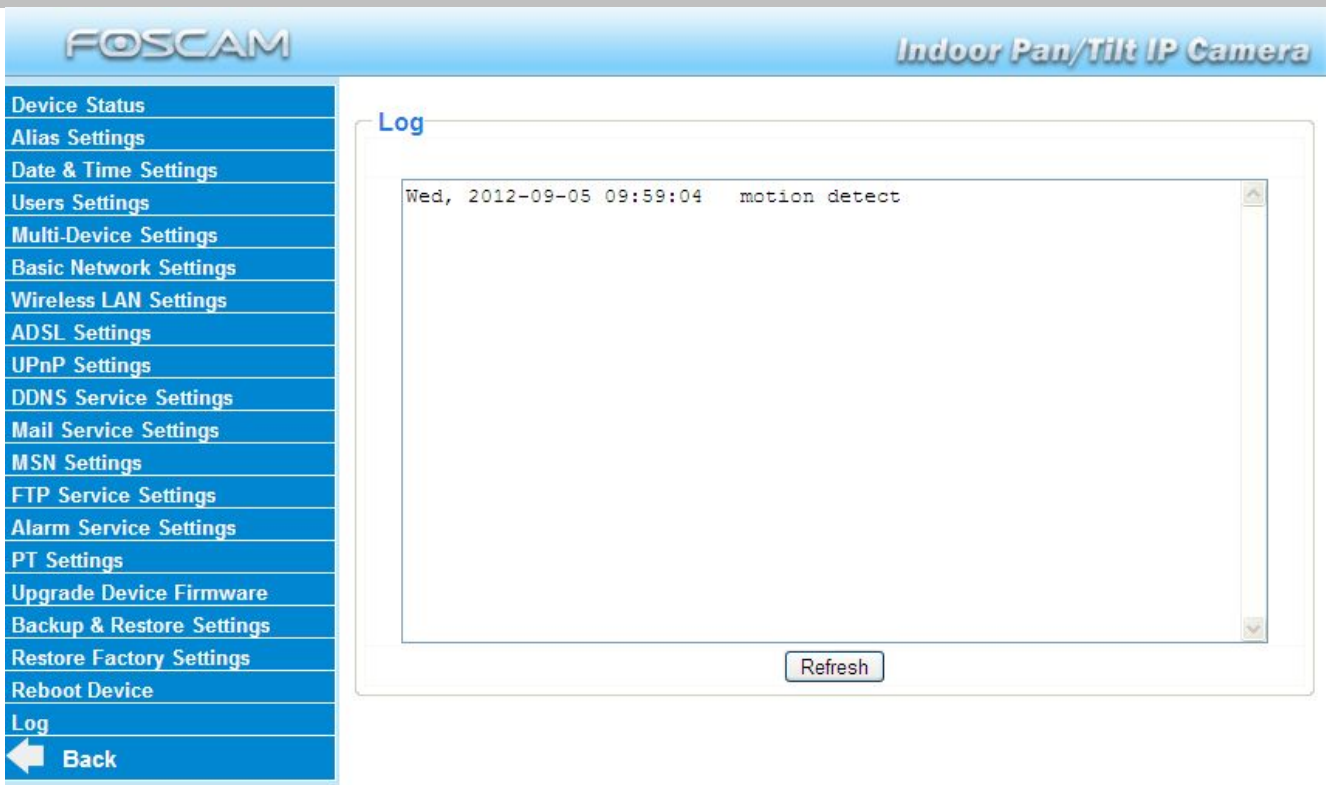

Figure 3.55

3.21 Back

This will take you back to the surveillance window.



4 Appendix

4.1 Frequently Asked Questions

NOTE: Always verify network connections are working by checking the status of the indicators on the network server, hub and network card.

4.1.1 I have forgotten the administrator username and/or password

To reset the administrator username and password, press and hold down the RESET BUTTON for 10 seconds. Upon releasing the reset button, the username and password will return to the factory default administrator username and password. Please power on the camera before reset
 Default administrator username: **admin**

Default administrator password: No password

4.1.2 Subnet doesn't match, dbclick to change

If the IP Camera Tool shows the error "Subnet doesn't match, dbclick to change!", select **Obtain IP from DHCP server**.

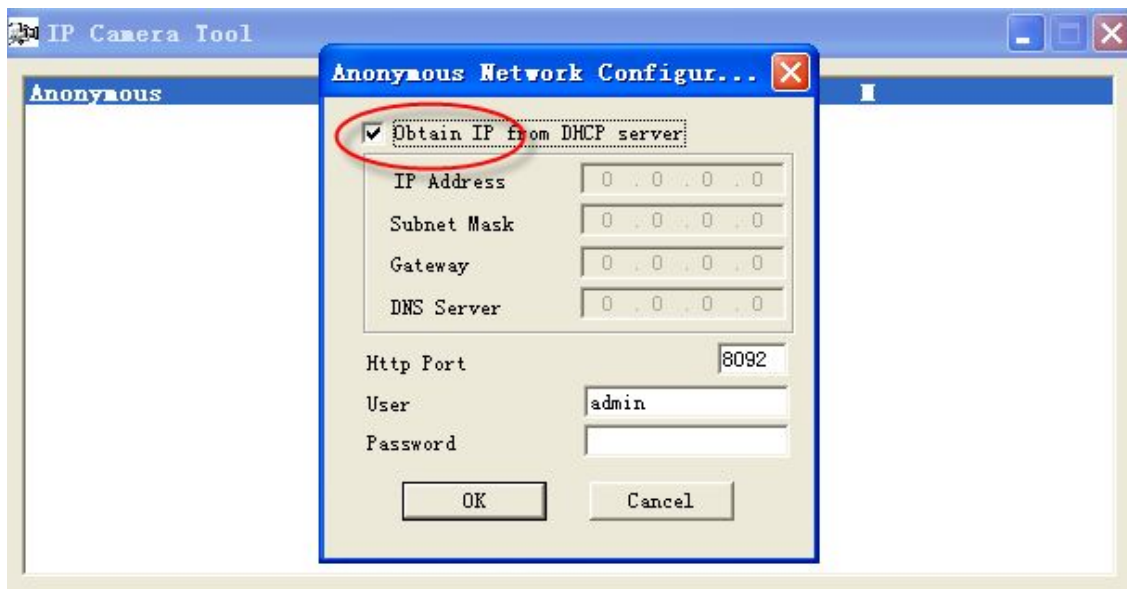

If this error still exists after obtaining an IP from the DHCP server, check the local area connection of your computer and verify the subnet and gateway of the camera which should be the same subnet of your computer.

4.1.3 No Pictures Problems

Video streaming is managed by the ActiveX controller. If the ActiveX controller isn't installed correctly you will see no video image. There are two ways to resolve this problem:

- 1) Reinstall "IP Camera Tool" and ActiveX controller (recommended) .
- 2) Download ActiveX controller and set the security setting of IE: IE browser → Tool → Internet

Proper→Security→Custom Level→ActiveX control and Plug-ins. The first three options of front should be set to be “Enable”, The ActiveX programs read by the computer will be stored. As follows:

Enable: Download unsigned ActiveX controls

Enable: Initialise and script ActiveX controls not marked as safe

Enable: Run ActiveX controls and plug-ins

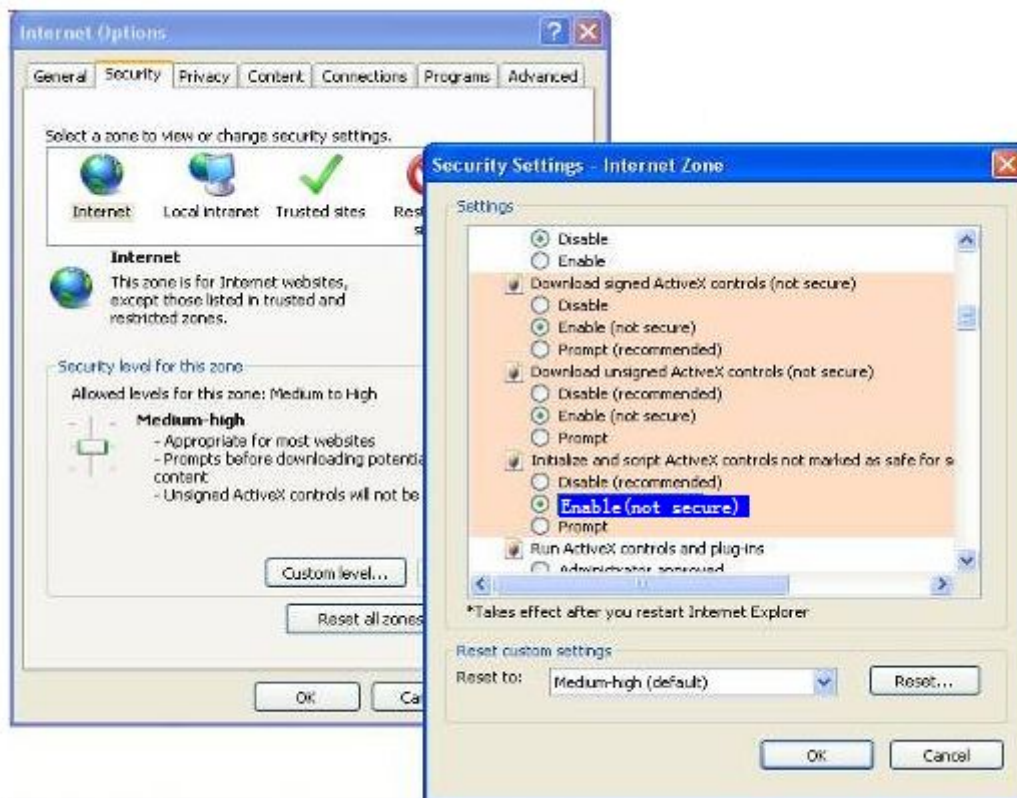

Figure 4.1

If you allow the ActiveX to run, but still can not see living video and a red cross in the center of the video. Please select another port number. Don't use port 80, use port 85, 8005.etc.

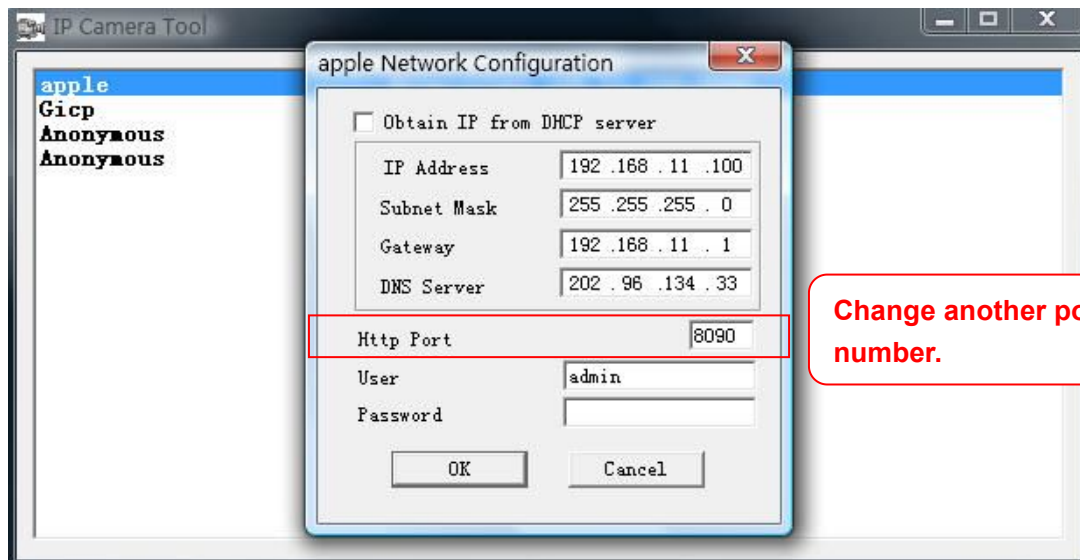

Figure 4.2

NOTE: Make sure that your firewall or anti-virus software does not block the camera or ActiveX. If you cannot see live video, try shutting down the firewall or anti-virus software and try again.

4.1.4 Can't access IP camera on internet

Possible reasons why camera is not accessible on the internet:

- 1) ActiveX controller is not installed correctly
- 2) The port which the camera uses is blocked by a Firewall or Anti-virus software. Try changing to another port number. (Figure 4.2)
- 3) Port forwarding is not successful (Figure 3.30)

Double check these settings and make sure they are correct.

4.1.5 IP Camera Tool could not find camera's IP

Verify that the network cable is securely fastened to the camera.

Make sure that DHCP is enabled on your router, do not enable MAC address filter.

Make sure that the firewall or anti-virus software does not block the camera. You can add the camera as a trusted site on your firewall or anti-virus software.

4.1.6 UPnP always failed

UPnP only contains port forwarding in our recent software. Sometimes, it may be fail to do port

forwarding automatically because of the firewall or anti-virus software. It may also be due to the router's security settings. We recommend manually configuring port forwarding the camera can be viewed on the internet.

4.1.7 Couldn't find the shortcut on the desktop after install IP camera tool

If you use Windows7 or Vista and the shortcut is missing after installing the IP camera tool, check the path of IP Camera program.

For example, if it was pointing to C:\Windows\System32\IPCamera.exe.

Please fix this by pointing the shortcut to the correct path

C:\Windows\SysWOW64\IPCamera.exe. After this you should be able to use the shortcut without any problems.

4.1.8 I can't change the record path

When you use Windows7 or Vista, you may be not able to change the record path because of the security settings of computer. Please add the camera as a trusted site to resolve this issue.

The steps are

IE browser→Tool→Internet Properties→Security→Trusted sites→Sites→Add

4.1.9 I can't find multi-device settings and record icon

Record and multi-device functionality are controlled by the ActiveX controller.

These functions are not available in Firefox, Google Chrome and Safari.

4.1.10 Camera cannot connect using wireless

If your camera cannot connect wirelessly after you set the wireless settings, unplug / plug the power cable. (for more details: **Wireless LAN settings** in **chapter 3.7**)

Usually, camera can't connect wireless mainly because of incorrect settings.

Verify that the SSID is correct; use the same encryption for router and camera. Share key should not contain special characters, only word and number will be better. Disable MAC address filtering.

4.1.11 Can't see other cameras listed in multi-device when using remote

access

If you want to view all the cameras via the WAN, verify that each camera added in the multi-device settings can be accessed by using the DDNS name and port number. Use the DDNS domain name not the camera's LAN IP. (For more details see: How to add cameras in WAN)

4.1.12 Only see black screen or undefined characters when using remote

login

If you could access the login page remotely, this indicates that your DDNS settings are correct. If you are unable to see live video but only some undefined characters, this may be due to the internet speed issues or the camera using Wi-Fi.

4.2 Default Parameters

Default network Parameters

IP address: obtain dynamically

Subnet mask: 255.255.255.0

Gateway: obtain dynamically

DHCP: Disabled

DDNS: Embedded FOSCAM domain name

Username and password

Default administrator username: **admin**

Default administrator password: No password

4.3 Specifications

ITEMS		F18910W
Image Sensor	Image Sensor	Color CMOS Sensor
	Display Resolution	640 x 480 Pixels(300k Pixels)
	Lens	f: 2.8mm,F:2.4
	Mini. Illumination	0.5Lux

Lens	Lens Type	Glass Lens
	Viewing Angle	60 degree
	IR_CUT	Filter will switch automatically
Video	Image Compression	MJPEG
	Image Frame Rate	15fps(VGA),30fps(QVGA)
	Resolution	640 x 480(VGA), 320 x 240(QVGA)
	Flip Mirror Images	Vertical / Horizontal
	Light Frequency	50Hz, 60Hz or Outdoor
	Video Parameters	Brightness, Contrast
Audio	Input	Built-in Microphone
	Output	Built-in Speaker,with a audio jack
	Audio Compression	MJPEG
Communication	Ethernet	One 10/100Mbps RJ-45
	Supported Protocol	HTTP,FTP,TCP/IP,UDP,SMTP,DHCP,PPPoE,DDNS,UPnP,GP RS
	Wireless Standard	IEEE 802.11b/g/n
	Data Rate	802.11b: 11Mbps(Max.) 802.11g: 54Mbps(Max.) 802.11n: 150Mbps(Max.)
	Wireless Security	WEP & WPA & WPA2 Encryption
	Infrared Light	11 IR LEDs, Night visibility up to 8 meters
	Dimension	117(L) x114(W) x129mm(H)
	Gross Weight	785g
	Net Weight	323g
Power	Power Supply	DC 5V/2.0A (EU,US,AU adapter or other types optional)
	Power Consumption	5Watts (Max.)
Environment	Operate Temper.	0° ~ 55°C (32°F ~ 131°F)
	Operating Humidity	20% ~ 85% non-condensing
	Storage Temper.	-10°C ~ 60° (14°F ~ 140°F)
	Storage Humidity	0% ~ 90% non-condensing
PC Requirements	CPU	2.0GHZ or above
	Memory Size	256MB or above
	Display Card	64M or above
	Supported OS	Microsoft Windows 2000/XP/Vista/Windows7-32bit/Windows7- 64bit/Windows8- 32bit/Windows8-64 bit / mac
	Browser	IE 6.0, IE7.0, IE8.0,IE9.0, Firefox2.0,Firefox3.0, Google Chrome, Safari or other standard browsers
Certification	CE,FCC,CSA,ROHS	
Warranty	Limited 2-years warranty	

Attention: Power adapter should be used between 0°C-40°C, and 5%-90% relative humidity.

5 Phone Apps

FOSCAM provides iOS APP for iOS users, which helps to view and listen to your world anywhere..... anytime.

Search and install **Foscam Viewer** on App Store or Google Play for Android or iOS devices.

6 Obtaining Technical Support

While we hope your experience with the IPCAM network camera is enjoyable and easy to use, you may experience some issues or have questions that this User's Guide has not answered.

Please contact support via e-mail at support@foscam.us. You can also reach technical support at 1-800-930-0949 by following the automated instructions.

