

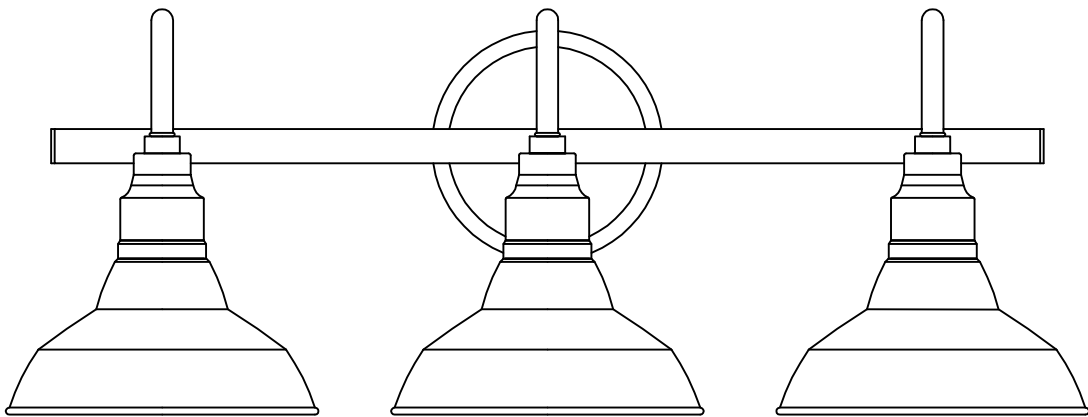

ALL • TOGETHER • BETTER

USE AND CARE GUIDE

DALE 3 LIGHT VANITY -#93515



Questions, problems, missing parts? Before returning to the store,
call Kenroy Home Customer Service
8 a.m.-6 p.m., EST, Monday-Friday

904-642-4340

THANK YOU

We appreciate the trust and confidence you have placed in Kenroy Home through the purchase of this vanity.
We strive to continually create quality products designed to enhance your home.
Thank you for choosing us!

Table of Contents

Safety Information	2
Warranty	2
Pre-Installation	3
Planning Installation	3
Package Contents	4
Installation	5 , 6, 7
Care and Cleaning	7
Troubleshooting	7

Safety Information

Consult a qualified electrician with any electrical questions you may have.



IMPORTANT: Inspect the wire insulation for any cuts, abrasions, or exposed copper that may have occurred during shipping. If there is a defect in the wire, do not continue the assembly process. Please call our Customer Service Team at 904-642-4340.

Warranty

1-YEAR LIMITED WARRANTY

WHAT IS COVERED

The manufacturer warrants this vanity to be free from defects in the materials and workmanship for a period of one (1) year from date of purchase. This warranty applies only to the original consumer purchaser and only to products used in normal use. If this product is found to be defective, the manufacturer's only obligation, and your exclusive remedy, is the repair or replacement of the product at the manufacturer's discretion, provided that the product has not been damaged through misuse, abuse, accident, modifications, alterations, neglect or mishandling. This warranty shall not apply to any product that is found to have been improperly installed, assembled, or used in any way not in accordance with the instructions supplied with the product. This warranty shall not apply to a failure of the product as a result of an accident, misuse, abuse, negligence, alteration, faulty installation, or any other failure not relating to faulty material or workmanship.

WHAT IS NOT COVERED

This warranty shall not apply to the finish on any portion of the product due to weathering, as this is considered normal wear. The manufacturer does not warrant and specifically disclaims any warranty, whether expressed or implied, other than the warranty contained herein. The manufacturer specifically disclaims any liability and shall not be liable for any consequential or incidental loss or damage, including but not limited to, any labor or expense costs involved in the replacement or repair of the product.

Contact the Customer Service Team at 904-642-4340.

Pre-Installation

PLANNING INSTALLATION

Read all instructions before assembly.

To avoid damaging this product, assemble it on a soft, non-abrasive surface such as carpet or cardboard. Inspect each part for defects that may have occurred during shipping.

Keep your receipt and these instructions for proof of purchase.

 NOTE: This vanity requires the use of three 120V, 60Hz, 60-Watt max, medium-base type A bulbs (not included). Do not exceed the recommended wattage.

TOOLS REQUIRED

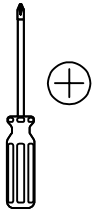

Phillips screwdriver

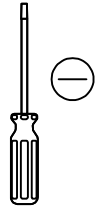

Flathead screwdriver

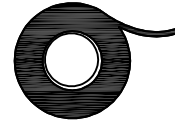

Electrical tape



Wire strippers



Wire cutters

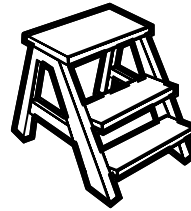

Ladder

HARDWARE INCLUDED

 NOTE: Hardware not shown to actual size.

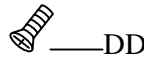
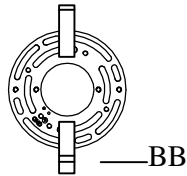

Part	Description	Quantity
AA	Wire nut	3
BB	Mounting plate	1
CC	Outlet box screw	2
DD	Small screw	1
EE	Ground screw	1

Pre-Installation (continued)

PACKAGE CONTENTS

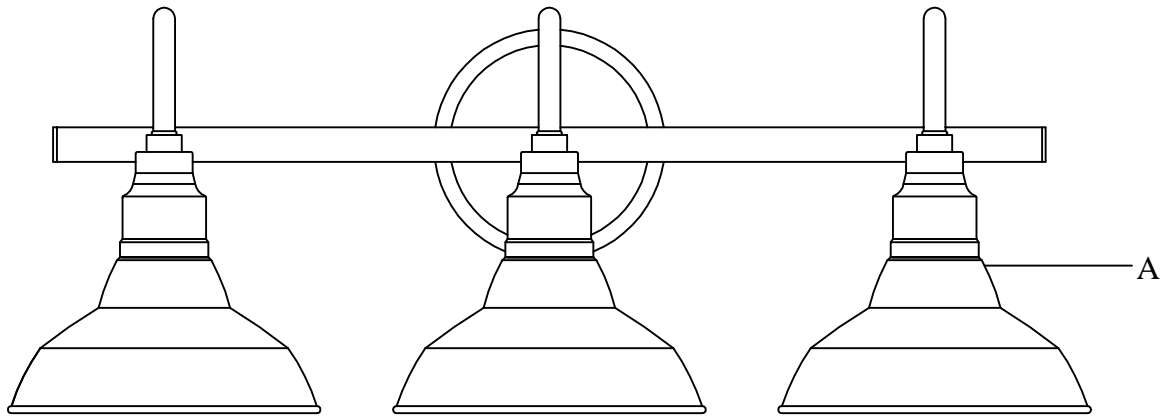

Part	Description	Quantity
A	Fixture body	1

Installation instructions

1. Installing the mounting plate



CAUTION: Ensure the power is off at the main fuse box prior to beginning installation.

- Turn off the switch at the wall.
- Turn the power off at the main fuse box.
- Attach the mounting plate (BB) to the outlet box using the outlet box screws (CC).
(**Important note:** This vanity can be mounted up or down, make sure the mounting bracket is facing up or down as you desired).

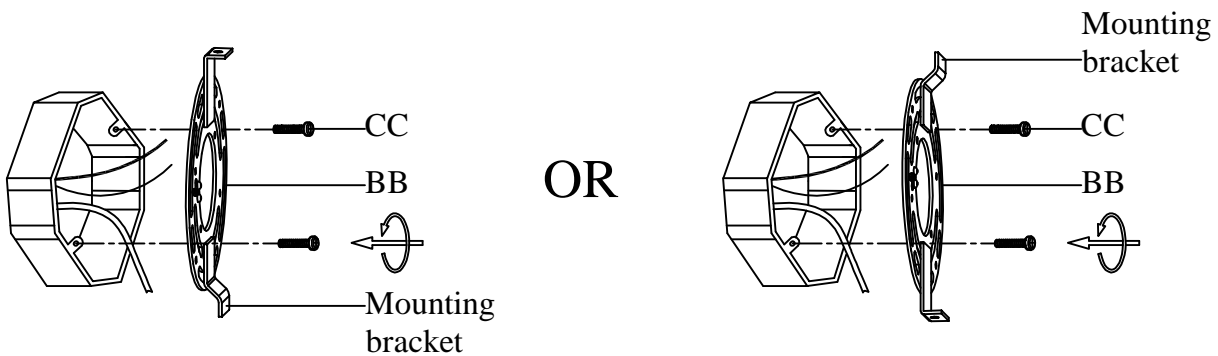

2. Connecting the wires

- Install the fixture bare copper wire (1) under the ground screw (EE) on the mounting plate (BB).
- Connect the fixture bare copper wire (1) to the green (or bare, or green & yellow) supply ground wire (2) in the outlet box using a wire nut (AA).
- Connect the white fixture wire (3) to the white (or ribbed) supply wire (4) in the outlet box using a wire nut (AA).
- Connect the black fixture wire (5) to the black (or red, or blue) supply wire (6) in the outlet box using a wire nut (AA).

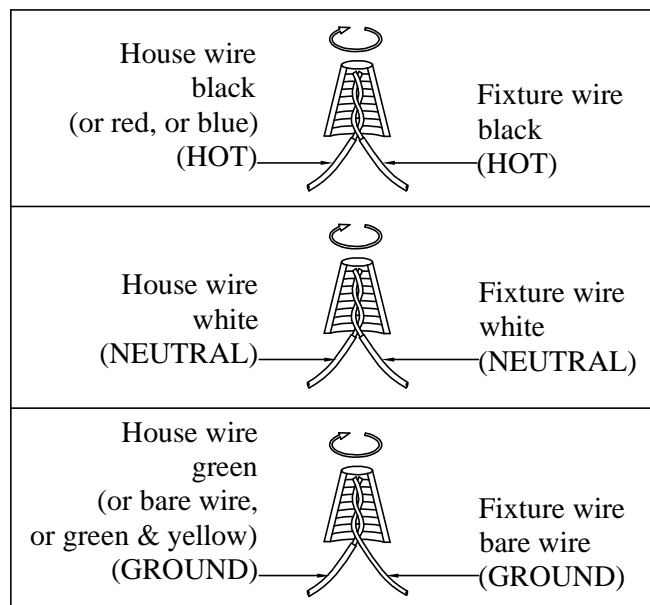
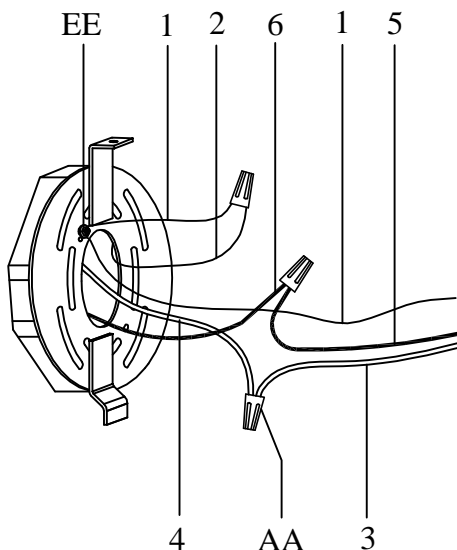

Installation instructions (continued)

3. Hanging the fixture body

- Raise the fixture body (A) to wall, insert the mounting bracket into the slot in the backplate, and then secure the backplate to the wall with the small screw (DD).

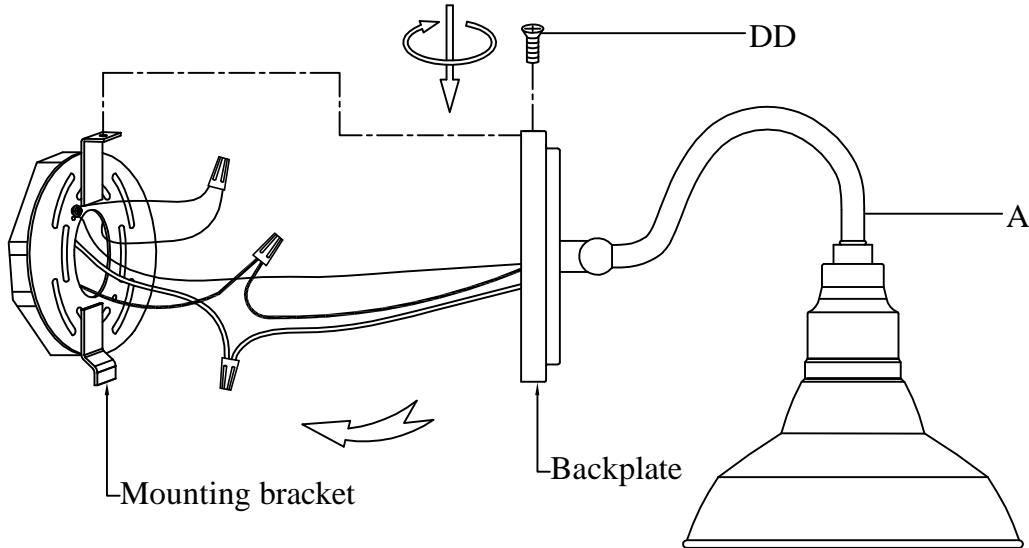

4. Assembling the bulbs

- Prior to installing the bulbs, please inspect sockets for silica packet, if packet is present, remove and throw away, do not expose to children and pets.
- Install one 120V, 60Hz, 60-watt max. medium-base type A bulb (not included) into each socket of the light fixture.

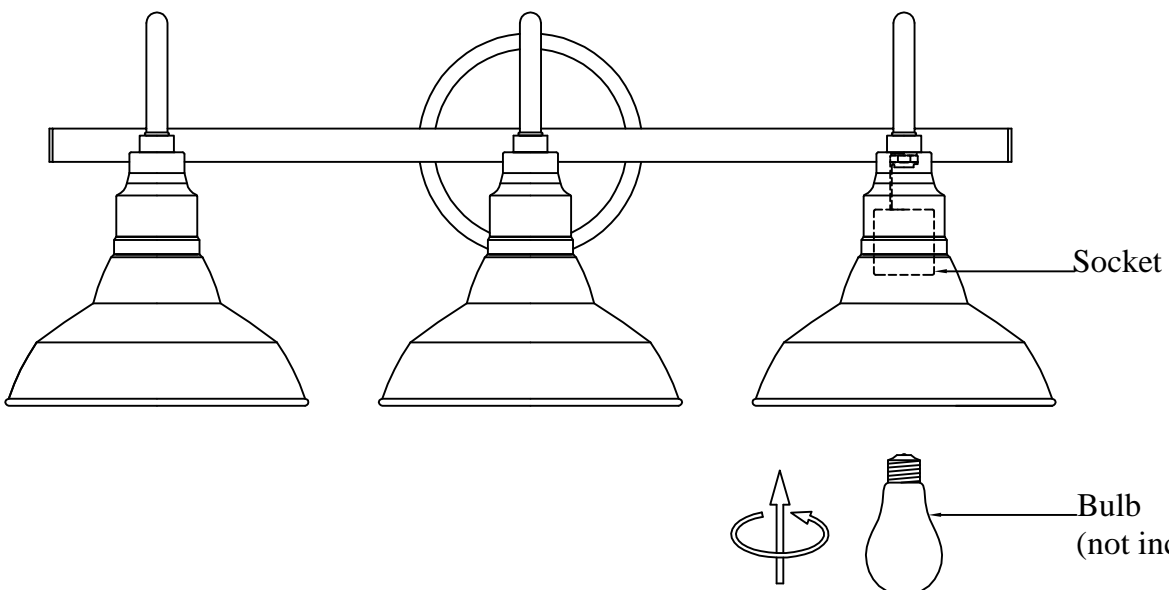

Care and Cleaning

- Clean the light fixture with a soft, dry cloth. Do not use any cleaners with chemicals, solvents, or harsh abrasives.

Troubleshooting

Problem	Possible Cause	Solution
The bulb will not light.	□ The bulb is burned out.	□ Replace the light bulb.
	□ The power is off.	□ Ensure that the power supply is turned on.
	□ There is a faulty wire connection.	□ Check the wiring.
	□ The circuit breaker is off.	□ Ensure that the circuit breaker is set in the on position.
The fuse blows or a circuit breaker trips when the light is turned on.	□ There is an exposed wire. □ There are too many items on one circuit.	□ Discontinue use of the light fixture. □ Contact a qualified electrician or call the Customer Service Team at 904-642-4340. □ Unplug other items on the circuit.



ALL • TOGETHER • BETTER



www.kenroyhome.com

CUSTOMER SUPPORT TEAM

For any additional questions or concerns please contact our Customer Support Team:

 **904-642-4340**

 **@KenroyHome**

 **customerorders@kenroyhome.com**