

B / BL Corner Braces

Angles & Straps

These multi-purpose braces are designed to provide reinforcement for 90° wood-to-wood connections.

Materials: 12 gauge
Finish: G90 galvanizing

Some model designs may vary from illustration shown

Installation:

- Use all specified fasteners. See Product Notes, page 18.

MiTek USP Stock No.	Ref. No.	Steel Gauge	Dimensions (in)		Fastener Schedule				Code Ref.
			W	L	Nails ²		Bolts ¹		
					Qty	Type	Qty	Type	
B23	--	12	2	2-5/8	6	16d	--	--	--
B24	--	12	2	3-5/8	8	16d	--	--	
BL3	A33	12	1-1/4	3-1/16	8	16d	--	--	
BL4	A44	12	1-1/4	4-13/16	10	16d	--	--	
BL6	--	12	1-1/4	6-9/16	12	16d	--	--	
BL8	--	12	1-1/4	8-5/16	14	16d	--	--	
B66	A66	12	1-1/2	6	--	--	4	3/8	
B88	A88	12	2	8	--	--	6	3/8	

1) Bolts shall conform to ASTM A 307 or better.
 2) **NAILS:** 16d nails are 0.162" dia. x 3-1/2" long.



Typical B66 installation

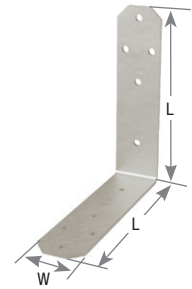

BL4

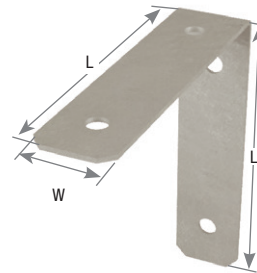

B66

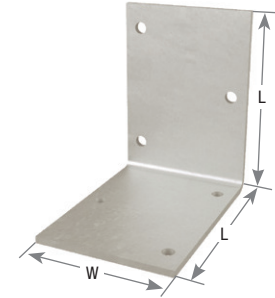

B23

KHL Heavy Angles

Designed for heavy-duty reinforcement of 90° framing intersections.

Materials: See chart
Finish: Primer
Options: See chart for Corrosion Finish Options

Installation:

- Use all specified fasteners. See Product Notes, page 18.
- **Connectors are not load rated.**



Typical KHL35 installation

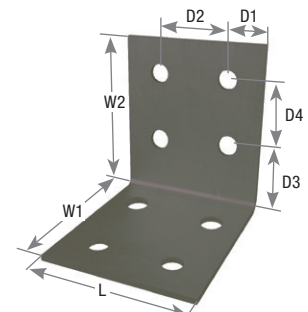

KHL55

MiTek USP Stock No.	Ref. No.	Steel Gauge	Dimensions (in)								Fastener Schedule			Corrosion Finish	Code Ref.
			W1	W2	L	D1	D2	D3	D4	Bolts ¹		Gussets			
										Qty	Dia.				
KHL33	HL33	7	3-1/4	3-1/4	2-1/2	1-1/4	--	2	--	2	5/8	--		--	
KHL35	HL35	7	3-1/4	3-1/4	5	1-1/4	2-1/2	2	--	4	5/8	--			
KHL35G	HL35G	7	3-1/4	3-1/4	5	1-1/4	2-1/2	2	--	4	5/8	1			
KHL37	HL37	7	3-1/4	3-1/4	7-1/2	1-1/4	2-1/2	2	--	6	5/8	--			
KHL335	SPECANGLE	3	3-1/2	5-1/4	3-1/2	--	--	--	--	4	1/2	--			
KHL43	HL43	3	4-1/4	4-1/4	3	1-1/2	--	2-3/4	--	2	3/4	--			
KHL46	HL46	3	4-1/4	4-1/4	6	1-1/2	3	2-3/4	--	4	3/4	--			
KHL49	HL49	3	4-1/4	4-1/4	9	1-1/2	3	2-3/4	--	6	3/4	--			
KHL53	HL53	7	5-3/4	5-3/4	2-1/2	1-1/4	--	2	2-1/2	4	5/8	--			
KHL55	HL55	7	5-3/4	5-3/4	5	1-1/4	2-1/2	2	2-1/2	8	5/8	--			
KHL57	HL57	7	5-3/4	5-3/4	7-1/2	1-1/4	2-1/2	2	2-1/2	12	5/8	--			
KHL73	HL73	3	7-1/4	7-1/4	3	1-1/2	--	2-3/4	3	4	3/4	--			
KHL76	HL76	3	7-1/4	7-1/4	6	1-1/2	3	2-3/4	3	8	3/4	1			
KHL79	HL79	3	7-1/4	7-1/4	9	1-1/2	3	2-3/4	3	12	3/4	2			

1) All bolts shall meet or exceed the specifications of ASTM A 307.

Corrosion Finish ■ Stainless Steel ■ Gold Coat ■ HDG ■ Triple Zinc

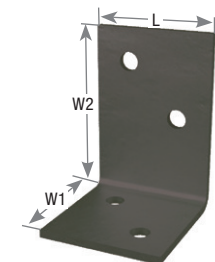

KHL335

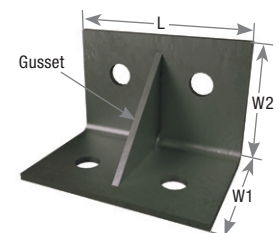

KHL35G