

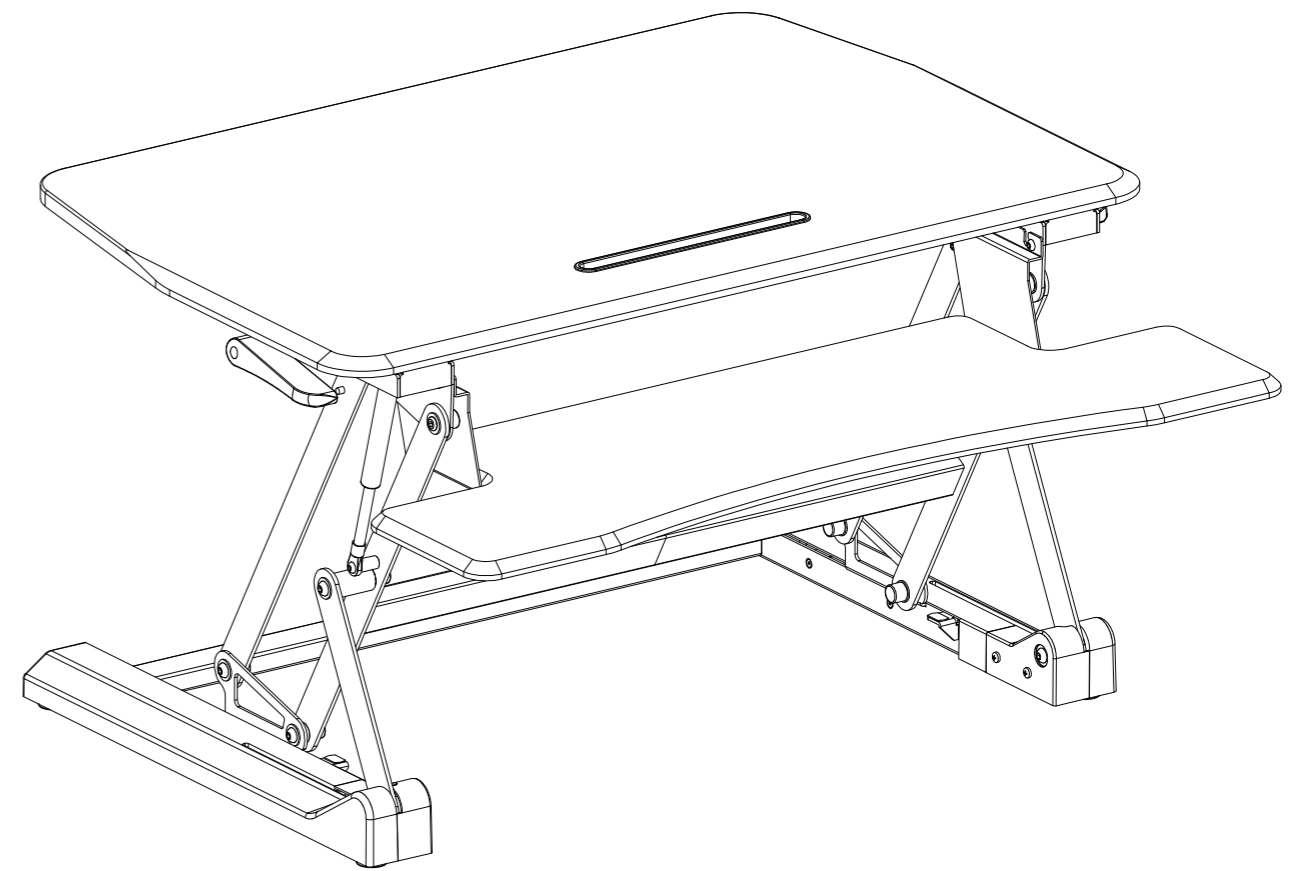

AIRLIFT® Gas-Spring Standing Desk Converter



Model #: OFF65807, OFF65808, OFF65840
OFF92008B, OFF92009B
V2020

Thank you for choosing Seville Classics! We hope that you enjoy your new sit-to-stand desk. Please read through this user guide for parts list, instructions, frequently asked questions, and contact information

Parts List

A. AIRLIFT® Desk (1)

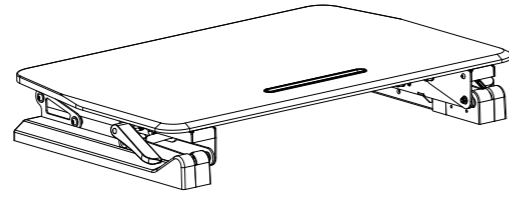

B. Brackets (2)

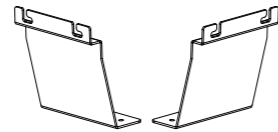

C. Tray (1)

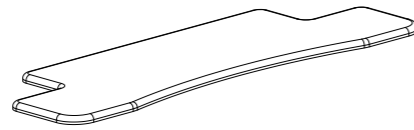

D. Zip-Ties (2)

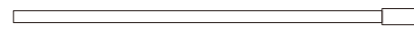

E. Allen Wrench (1)

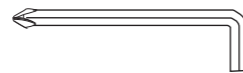

F. Wire Clip (4)

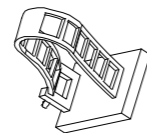

G. Screws (6)

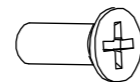

Required Tools (not included)



Please make sure you have all the parts on this list.

If you're missing parts, contact us for replacements at (800) 323-5565 or send an email to Support@SevilleClassics.com

Use Instructions

1. Pull up on both AIRLIFT® levers and desktop to lift.
2. Pull up on both AIRLIFT® levers and press down on desktop to lower.

FAQS

Q. Can I attach a monitor stand to it? What about dual monitors?

A. Yes! Be sure the desk is below it's 33 lbs. maximum weight limit.

Q. What size is the base?

A. Base measures 32.75 inches wide and 22 inches deep.

Q. Do I need to plug it in?

A. Nope! It's fully pneumatic. Just put it on the table and get started!

Specifications

Dimensions: 35.43" W x 23.23" D x (6.25" to 19.1") H

Maximum weight on tray: 5 lbs. (2 kgs)

Maximum weight capacity overall: 33 lbs. (15 kgs)

Customer Service Information

Telephone: (800) 323-5565



Fax: (310) 533-3899

Hours: 8:30 AM – 4:30 PM (PST)

Email: Support@SevilleClassics.com

Homepage: www.SevilleClassics.com

Safety

 Failure to follow these instructions may result in property damage or personal injury. 



DO NOT place devices on desk edge.

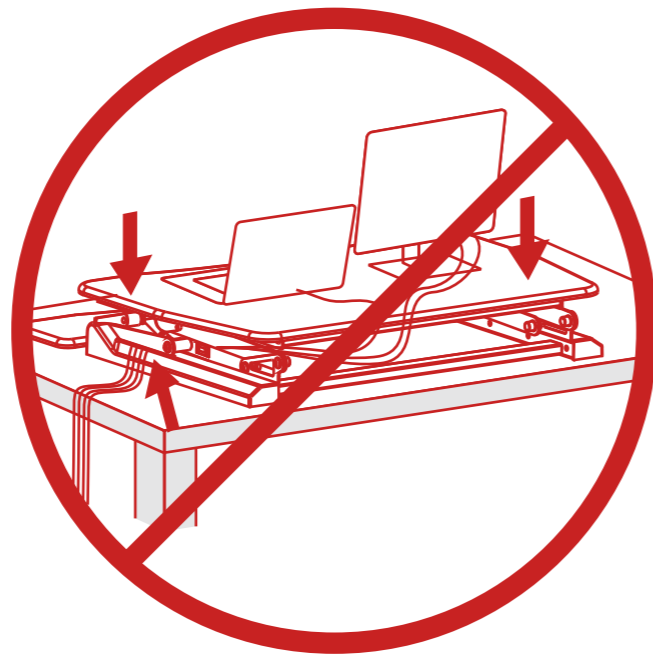

DO NOT route wires through desk legs.



MAKE SURE devices have cables long enough for the full-range (15 in/38 cm) of height-adjustment.



DO NOT quickly lift desktop when loaded.

Assembly Instructions

STEP 1. Remove AIRLIFT® DESK (A) from box and set on flat table.

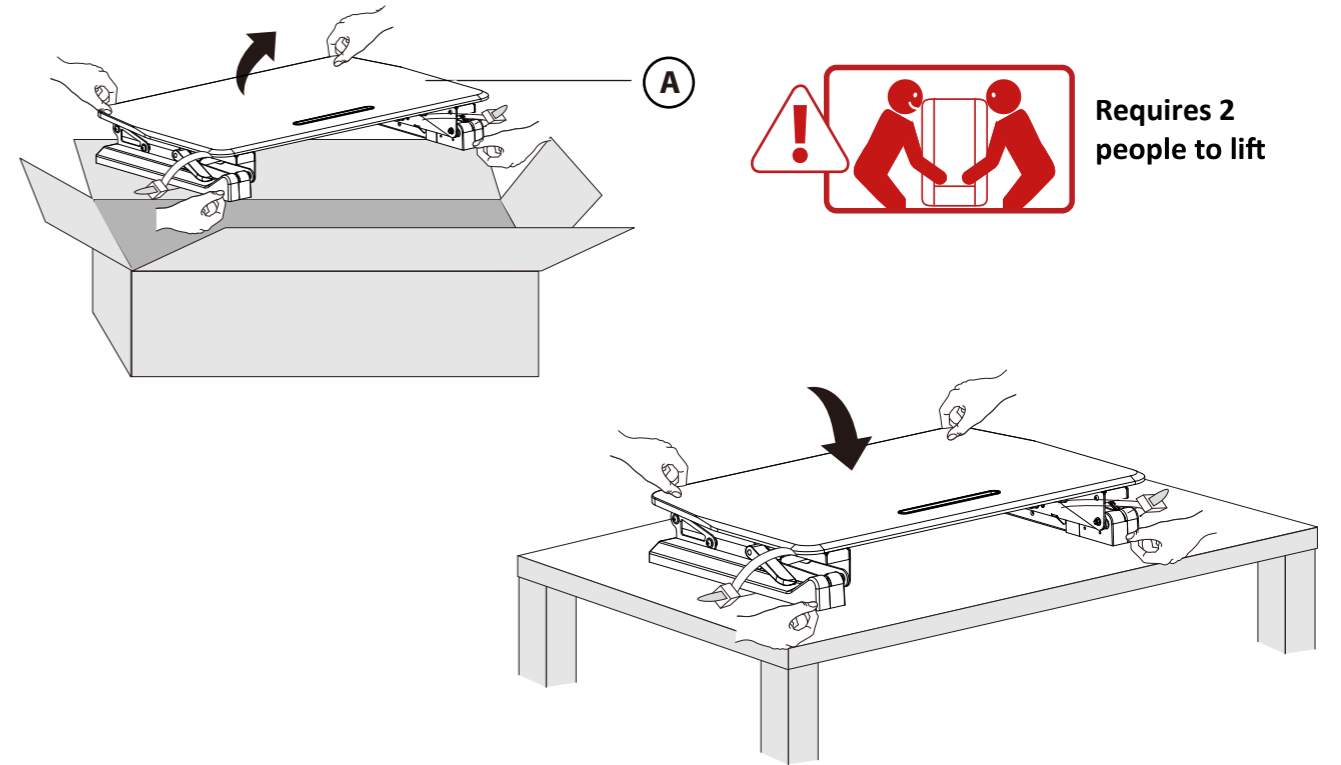

Requires 2 people to lift

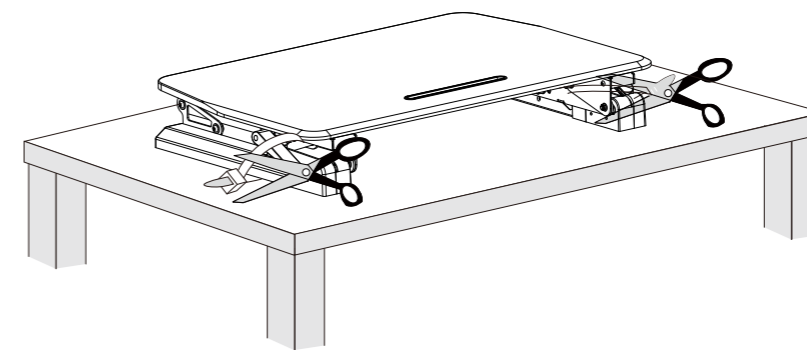

STEP 2.
Cut the plastic ties on both sides of the AIRLIFT® DESK (A).

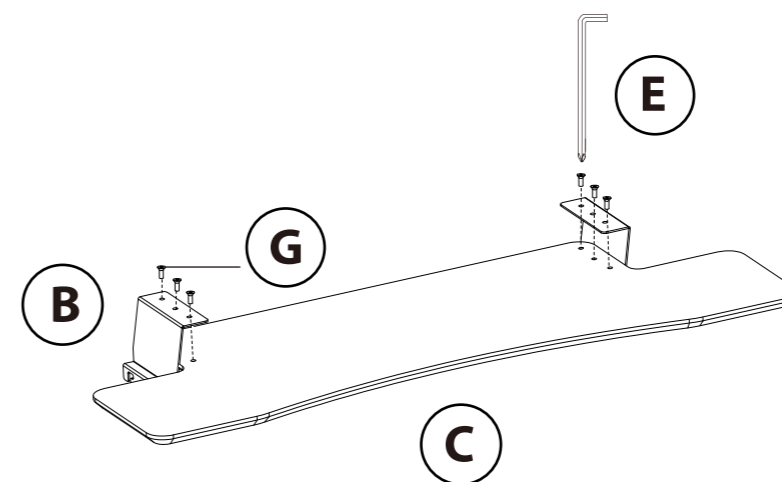

STEP 3.
Flip TRAY (C) upside down. Attach BRACKETS (B) to underside of TRAY (C) with SCREWS (G) and Allen Wrench (E).

STEP 4. Pull up on both AIRLIFT® levers and desktop to lift.

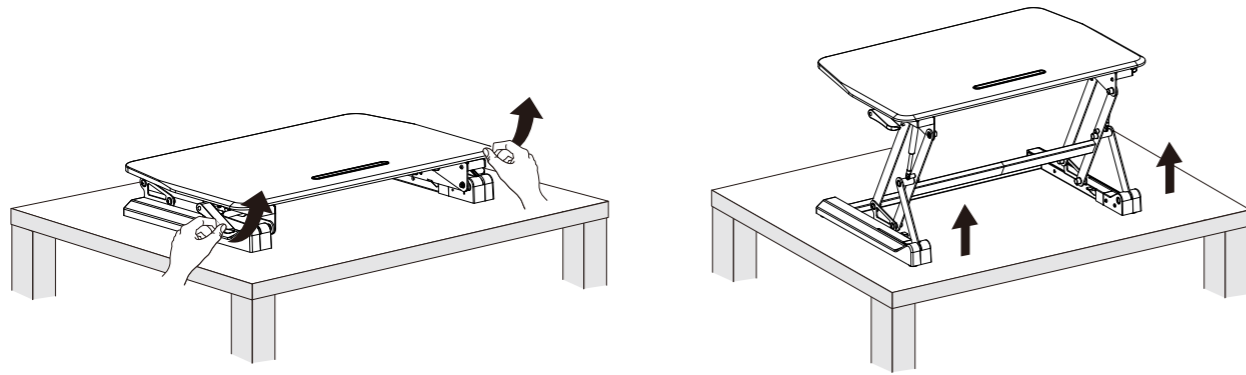

STEP 5. Hook BRACKETS (B) over the bolts on the inner legs of the AIRLIFT® DESK (A).

Tighten bolts clockwise with included ALLEN WRENCH (E).

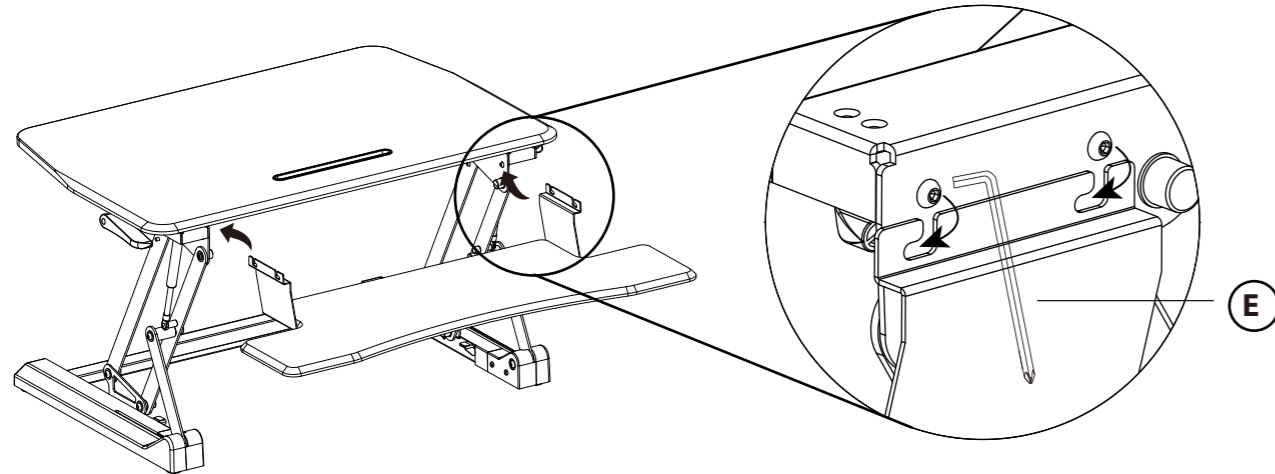

STEP 6. Place your belongings on the desktop to finish!

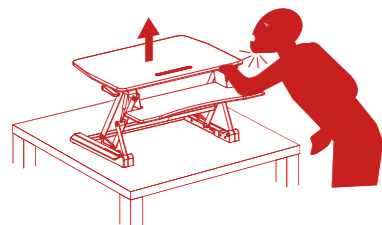
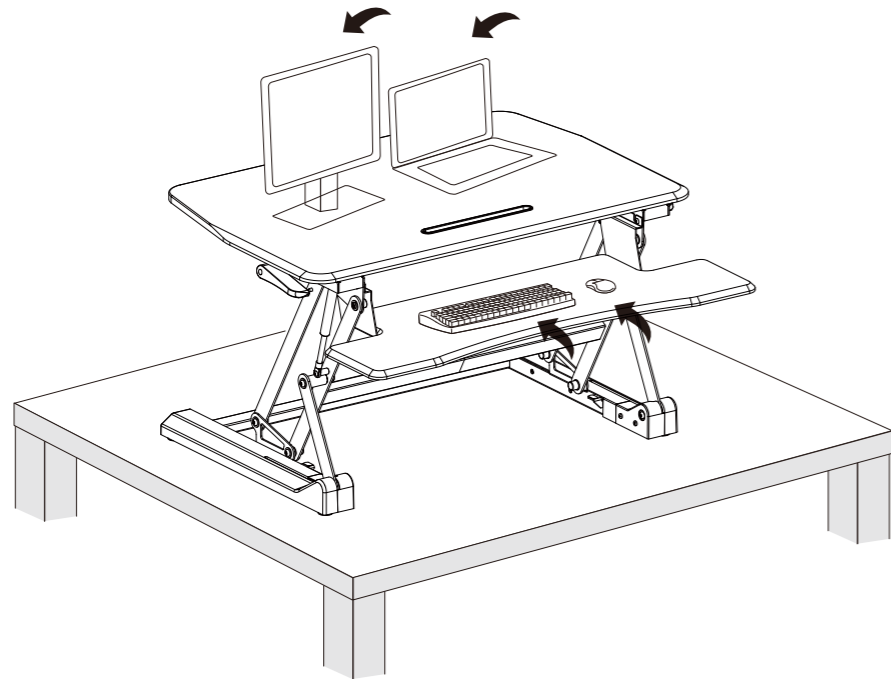

WARNING: DO NOT PLACE HANDS ON
DESK LEGS. MOVING PARTS CAN CRUSH.



Cable Management

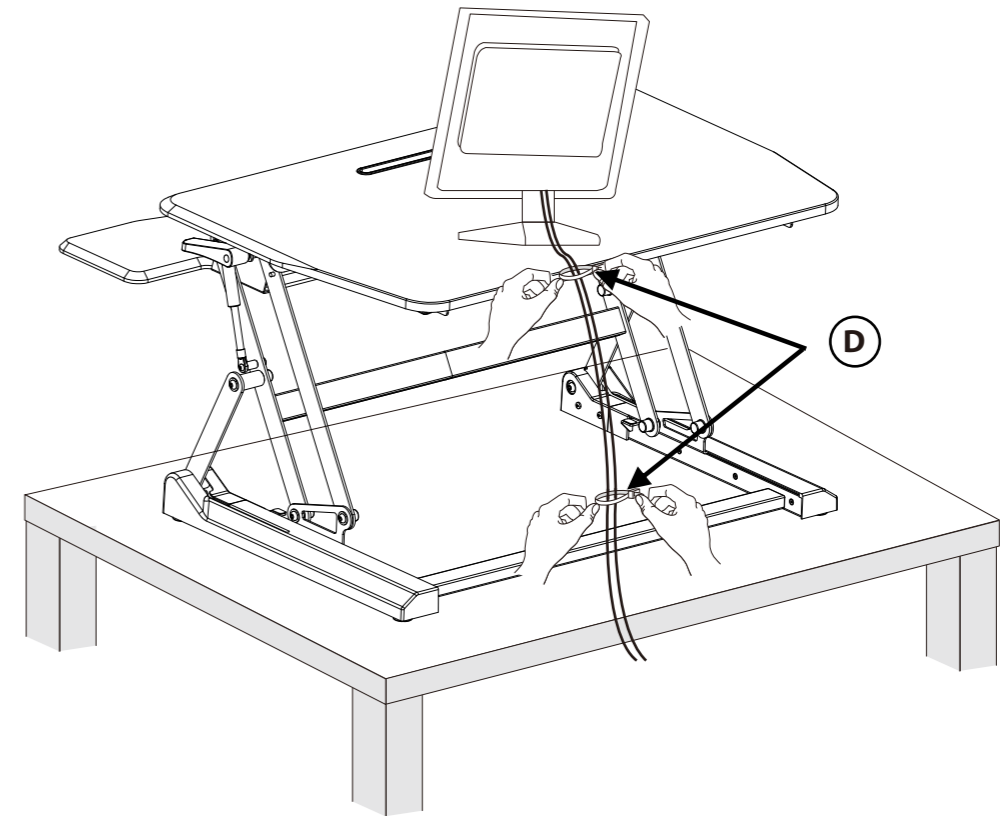

Organize loose cables with included ZIP TIES (D).

ALWAYS route your cables through the REAR of the desk.

NEVER route cables through the legs of the desk.

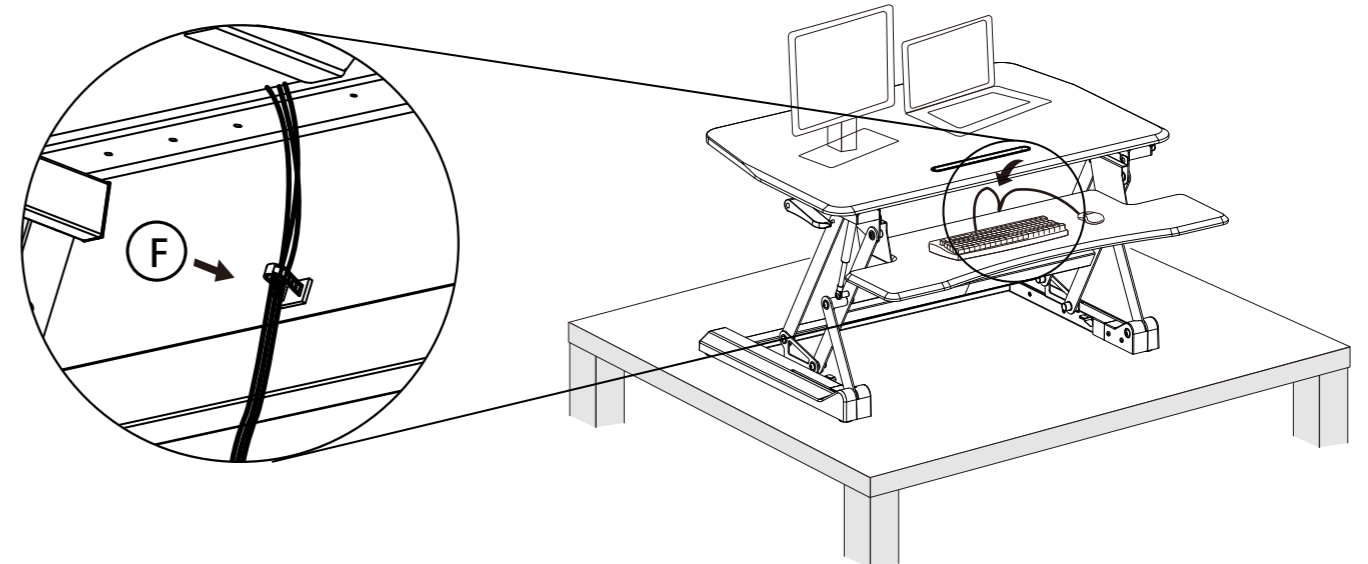

Stick the WIRE CLIP (F) to back of the crossbar. Use this clip to route cables from keyboards, mice and monitors through the REAR of the desk.