

## Model XPH07M/XPH07Z Parts List

A = Standard Equipment

O = Circuit Diagram

Item#	MJ Part#	Description	Q'ty	Unit
001	187921-4	HOUSING SET	1	
	C10 263005-3	RUBBER PIN 6	2	PC.
	D10	INC. 21		
002	815S70-8	XPH07 NAME PLATE	1	
003	266130-9	TAPPING SCREW BIND PT 3X16	7	PC.
004	232220-0	LEAF SPRING	2	PC.
005	126411-2	SPEED CHANGE LEVER ASSEMBL	1	
	C10 233438-6	COMPRESSION SPRING 4	2	PC.
006	419250-0	F/R CHANGE LEVER	1	PC.
007	650710-5	SWITCH C3JW-4B	1	
008	251468-5	- FLAT HEAD SCREW M6X22	1	PC.
009	766015-4	KEYLESS DRILL CHUCK 13	1	PC.
010	265995-6	TAPPING SCREW 4X18	4	PC.
011	126410-4	GEAR ASSEMBLY	1	
012	142263-3	INDICATOR PANEL COMPLETE	1	
013	424517-3	CUSHION	1	PC.
014	629116-8	STATOR COMPLETE	1	PC.
015	619336-2	ROTOR	1	
016	266130-9	TAPPING SCREW BIND PT 3X16	2	PC.
017	455011-4	REAR COVER	1	
018	620283-2	LED CIRCUIT	1	
019	643899-6	TERMINAL	1	PC.
020	803N96-2	CAUTION LABEL	1	
021	187921-4	HOUSING SET	1	
	C10 263005-3	RUBBER PIN 6	2	PC.
	D10	INC. 1		
A01	122576-8	STOPPER POLE ASS'Y	1	PC.
A02	126413-8	GRIP ASSEMBLY	1	
	C10 142652-2	POLE COMPLETE	1	
	C20 142653-0	ARM R COMPLETE	1	
	C30 265785-7	THUMB SCREW M5X10	1	PC.
	C40 266886-4	HEX. BOLT M8X65	1	
	C50 319129-4	ARM L	1	
	C60 931202-6	HEX. NUT M5	1	PC.
	C70 962055-2	RETAINING RING (INT) R-15	1	PC.
A03	251314-2	+ SCREW M4X12	2	PC.
A04	346449-3	HOOK	1	PC.
A05	452947-8	BIT HOLDER	1	PC.
A06	784637-8	+ BIT 2-45	2	PC.
A07	821524-1	PLASTIC CARRYING CASE	1	PC. (XPH07M)
	C10 162302-3	LATCH	2	PC.
	C20 325809-2	SHAFT	1	PC.
	C30 451749-9	HANDLE	1	PC.
	C40 453473-0	PLASTIC CASE LID	1	PC.
A08	***DC18RC	DC18RC FAST CHARGER	1	PC. (XPH07M)
A09	BL1840	BATTERY BL1840 SET (196402-7)	2	(XPH07M)
A10	450128-8	BATTERY COVER	1	PC. (XPH07M)

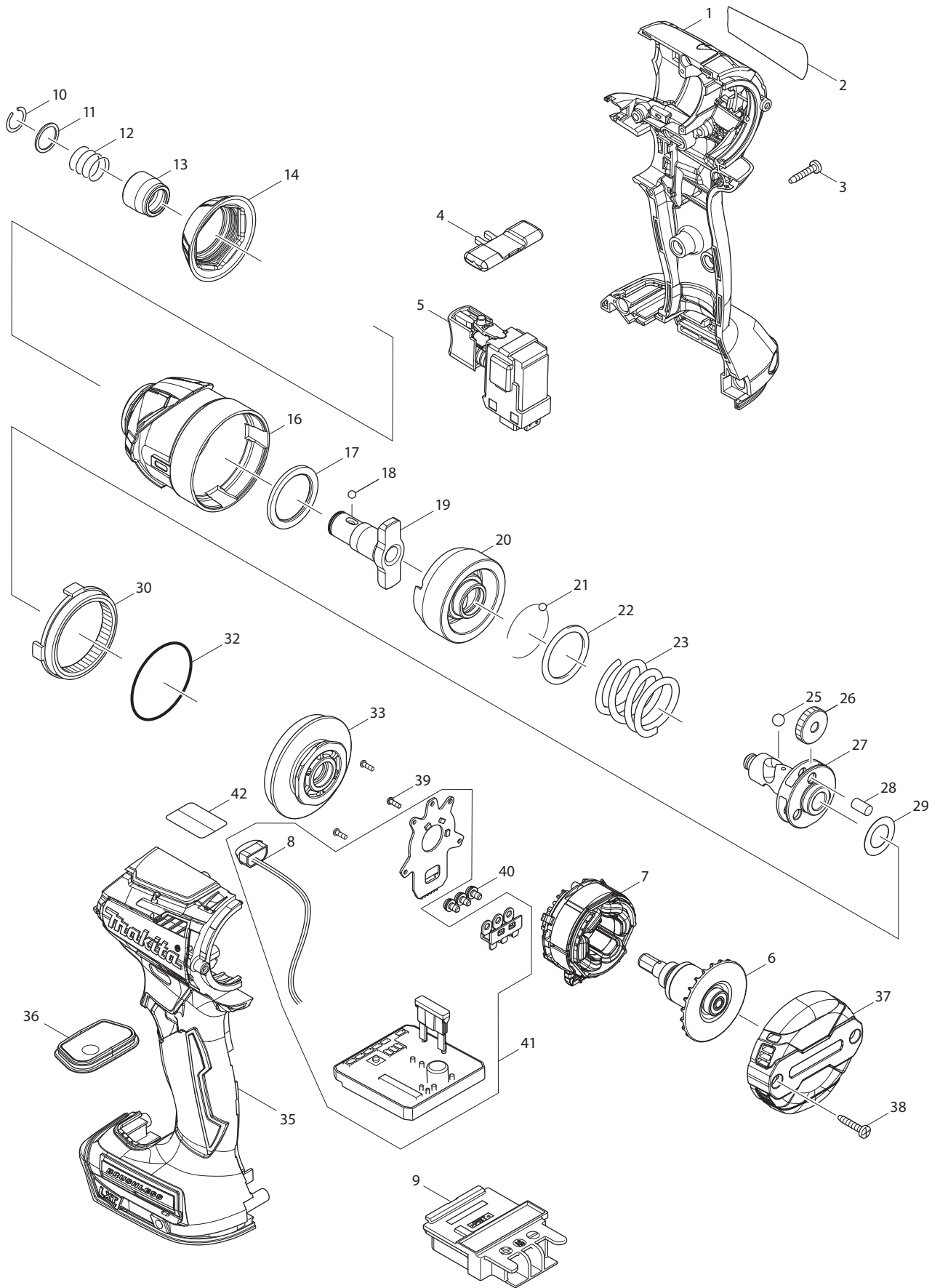

## Model XDT14M/R/Z Parts List

A = Standard Equipment

O = Circuit Diagram

Item#	Part#	Description	Q'ty Unit
001	183E36-5	HOUSING SET	1
	C10 263005-3	RUBBER PIN 6	2 PC.
	C20 252126-6	HEX. LOCKING NUT M4-7	2 PC.
	D10	INC. 35	
002	852L15-3	XDT14 NAME PLATE	1
003	266429-2	TAPPING SCREW 3X16	8 PC.
004	455053-8	F/R CHANGE LEVER	1 PC.
005	143975-1	SWITCH COMPLETE	1
006	619408-3	ROTOR	1
007	629217-2	STATOR	1 PC.
008	620557-1	LED CIRCUIT	1
009	643860-3	TERMINAL	1 PC.
010	231951-8	RING SPRING 11	1 PC.
011	267085-1	FLAT WASHER 12	1 PC.
012	233005-7	COMPRESSION SPRING 13	1 PC.
013	326068-1	BIT SLEEVE	1 PC.
014	424873-1	BUMPER	1
016	143951-5	HAMMER CASE COMPLETE	1
017	261155-8	NYLON WASHER 24	1 PC.
018	216001-0	STEEL BALL 3.5	2 PC.
019	326506-3	ANVIL M	1
020	326711-2	HAMMER	1 PC.
021	216001-0	STEEL BALL 3.5	24 PC.
022	267175-0	FLAT WASHER 24	1 PC.
023	234331-7	COMPRESSION SPRING 24	1 PC.
025	216041-8	STEEL BALL 5.6	2
026	227338-0	SPUR GEAR 22	3 PC.
027	326783-7	SPINDLE	1
028	268311-1	PIN 5	3 PC.
029	253314-8	THIN WASHER 15	1 PC.
030	221457-4	INTERNAL GEAR 51	1
032	213507-9	O RING 40	1 PC.
033	143976-9	BEARING BOX COMPLETE	1
035	183E36-5	HOUSING SET	1
	C10 263005-3	RUBBER PIN 6	2 PC.
	C20 252126-6	HEX. LOCKING NUT M4-7	2 PC.
	D10	INC. 1	
036	143954-9	SWITCH PLATE COMPLETE	1
037	456921-8	REAR COVER	1
038	266429-2	TAPPING SCREW 3X16	2 PC.
039	266490-9	TAPPING SCREW PT 2X6	3 PC.
040	652069-6	FLAT HEAD SCREW M3X6	3 PC.
041	620545-8	CONTROLLER	1
	D10	INC. 8	
042	809R92-2	CAUTION LABEL	1
A01	266622-8	+ TRUSS HEAD SCREW M4X12	1 PC.
A02	346449-3	HOOK	1 PC.
A03	450128-8	BATTERY COVER	1 PC.
A04	***DC18RC	DC18RC FAST CHARGER	1 PC. (XDT14M/R)

D10		COMPO-PARTS		
A05	BL1840B	BATTERY BL1840B SET	2	(XDT14M)
	BL1820B	BATTERY BL1820B SET	2	(XDT14R)
A06	824979-9	PLASTIC CARRYING CASE	1 PC.	(XDT14M/R)
C10	162302-3	LATCH	2 PC.	(XDT14M/R)

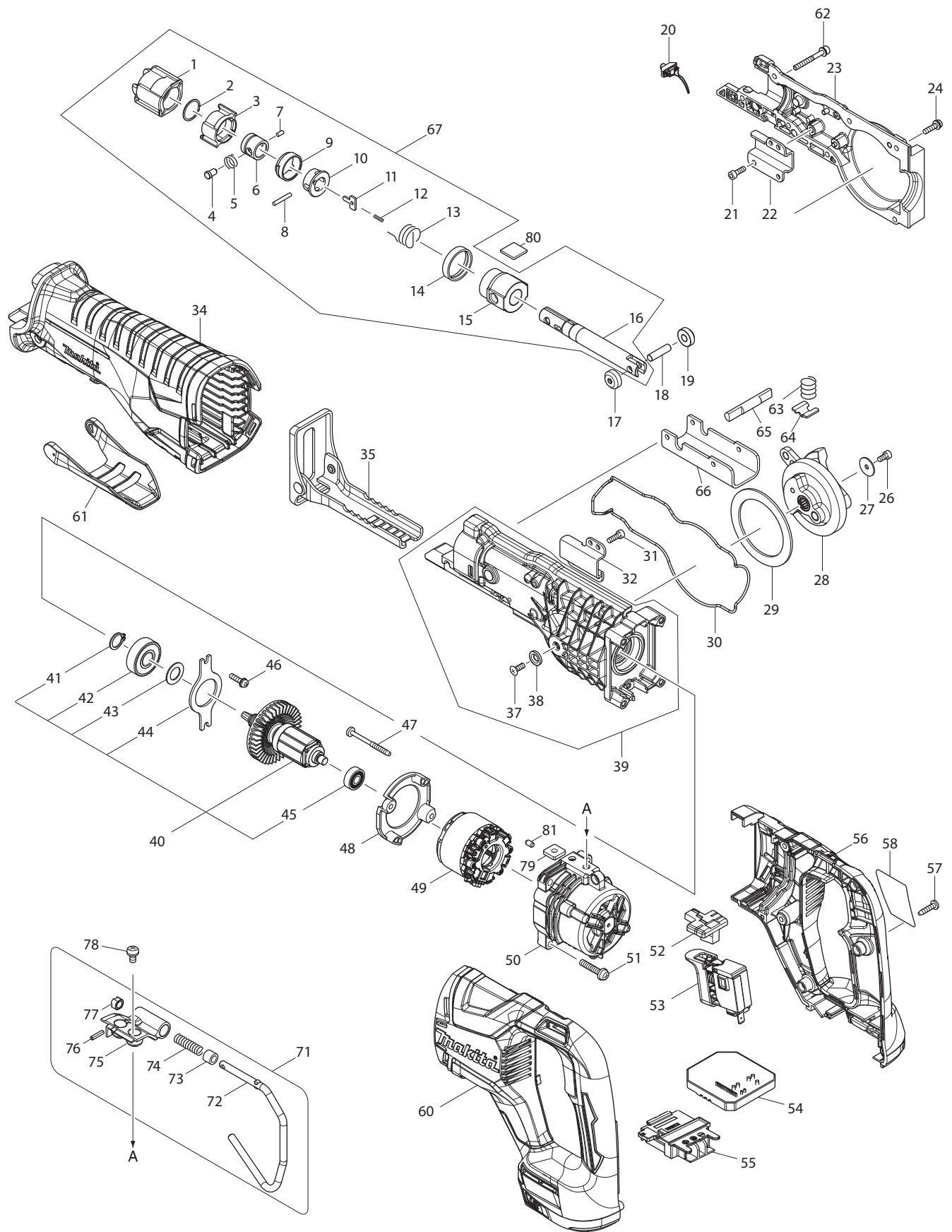

## Model XRJ05M/Z Parts List

A = Standard Equipment

O = Circuit Diagram

Item#	Part#	Description	Q'ty Unit
001	424763-8	PROTECTOR	1
002	257952-8	RETAINING RING (EXT) 18	1 PC.
003	310662-9	DRIVING SLEEVE	1
004	256569-4	SHOULDER PIN 5	1
005	234381-2	COMPRESSION SPRING 6	1
006	331720-8	GUIDE SLEEVE	1 PC.
007	268094-3	PIN 3	1 PC.
008	256158-5	PIN 3	1 PC.
009	417791-0	DRIVING SLEEVE GUIDE	1 PC.
010	418311-3	SLEEVE	1 PC.
011	345214-7	PUSH PLATE	1 PC.
012	233025-1	COMPRESSION SPRING 2	1 PC.
013	231687-9	TORSION SPRING 17	1 PC.
014	424762-0	RUBBER RING	1
015	143365-8	SLIDER GUIDE COMPLETE	1 PC.
	C10 213151-2	OIL SEAL 14	1 PC.
	C20 213174-0	X RING 14	1 PC.
016	161376-1	SLIDER	1
017	310663-7	ROLLER	1
018	268341-2	PIN 6	1
019	310663-7	ROLLER	1
020	620434-7	LED CIRCUIT	1 PC.
021	922117-8	HEX. SOCKET HEAD BOLT M4X12	2 PC.
022	346936-2	ROD GUIDE R	1
023	143362-4	GEAR HOUSING R COMPLETE	1 PC.
024	911128-8	PAN HEAD SCREW M4X16	5 PC.
026	922107-1	HEX. SOCKET HEAD BOLT M4X8	1 PC.
027	267491-0	FLAT WASHER 4	1
028	143359-3	GEAR COMPLETE	1 PC.
029	267490-2	FLAT WASHER 54	1
030	424764-6	SEAL RING	1
031	922117-8	HEX. SOCKET HEAD BOLT M4X12	2 PC.
032	346935-4	ROD GUIDE L	1
034	424765-4	INSULATION COVER	1
035	161374-5	SHOE	1
037	912112-6	COUNTERSUNK HEAD SCREW M4X10	1 PC.
038	253825-3	FLAT WASHER 6	1 PC.
039	123509-6	GEAR HOUSING L ASSEMBLY	1 PC.
	D10	INC. 37,38	
040-1	519418-9	ROTOR ASS'Y	1
	D10	INC. 41-45	
041	961052-5	RETAINING RING S-12	1 PC.
042	211129-9	BALL BEARING 6201DDW	1 PC.
043	253744-3	FLAT WASHER 12	1 PC.
044	285740-3	BEARING RETAINER 66	1
045	210062-2	BALL BEARING 607ZZ	1 PC.
046	911128-8	PAN HEAD SCREW M4X16	2 PC.
047	266069-6	TAPPING SCREW 4X45	2 PC.
048	456178-1	BAFFLE PLATE	1

049	629179-4	STATOR	1	
050	456179-9	MOTOR HOUSING	1	
051	911243-8	PAN HEAD SCREW M5X25	4 PC.	
052	456177-3	CHANGE BUTTON	1	
053	650759-5	SWITCH C3JW-6B-2	1	
054	620432-1	CONTROLLER A	1 PC.	
055	643899-6	TERMINAL	1 PC.	
056	183C47-8	HANDLE SET	1	
	C10 263005-3	RUBBER PIN 6	2 PC.	
	D10	INC. 60		
057	266326-2	TAPPING SCREW 4X18	6 PC.	
058	851P11-2	XRJ05 NAME PLATE	1	
059	807Y38-4	CAUTION LABEL	1	
060	183C47-8	HANDLE SET	1	
	C10 263005-3	RUBBER PIN 6	2 PC.	
	D10	INC. 56		
061	456176-5	LOCK LEVER	1	
062	266979-7	HEX.SOCKET HEAD BOLT M4X35 WR	2	
063	231231-2	COMPRESSION SPRING 12	1 PC.	
064	346938-8	SHOE LOCK PLATE	1	
065	326599-0	LOCK PIN	1	
066	346937-0	SHOE GUIDE PLATE	1	
067	123510-1	SLIDER ASSEMBLY	1 PC.	
	D10	INC. 1-16		
071	123455-3	HOOK ASSEMBLY	1 PC.	
	D10	INC. 72-77		
072	281223-1	HOOK	1	
073	262561-0	SLEEVE 6	1 PC.	
074	233455-6	COMPRESSION SPRING 7	1 PC.	
075	319344-0	JOINT	1	
076	951057-3	SPRING PIN 3-12	1 PC.	
077	310661-1	LOCK SLEEVE	1	
078	911206-4	PAN HEAD SCREW M5X10	2 PC.	
079	264002-2	SQUARE NUT M5	2 PC.	
080	424858-7	FELT 16X16	1 PC.	
081	263002-9	RUBBER PIN 4	1 PC.	
A01	194502-7	RECIPRO SAW BLADE SET	1 SET	
A03	821620-5	PLASTIC TOOL CASE	1	(XRJ05M)
	C10 162271-8	LATCH	2 PC.	(XRJ05M)
A05	450128-8	BATTERY COVER	1 PC.	(XRJ05M)
A06	***DC18RC	DC18RC FAST CHARGER	1 PC.	(XRJ05M)
	D10	COMPO-PARTS		
A07	BL1840B	BATTERY BL1840B SET (197268-8)	2	(XRJ05M)