

Item# 1000 000 000
Model# A101014900

HAMPTON BAY®

USE AND CARE GUIDE

SEAGROVE 10 X 12 GAZEBO

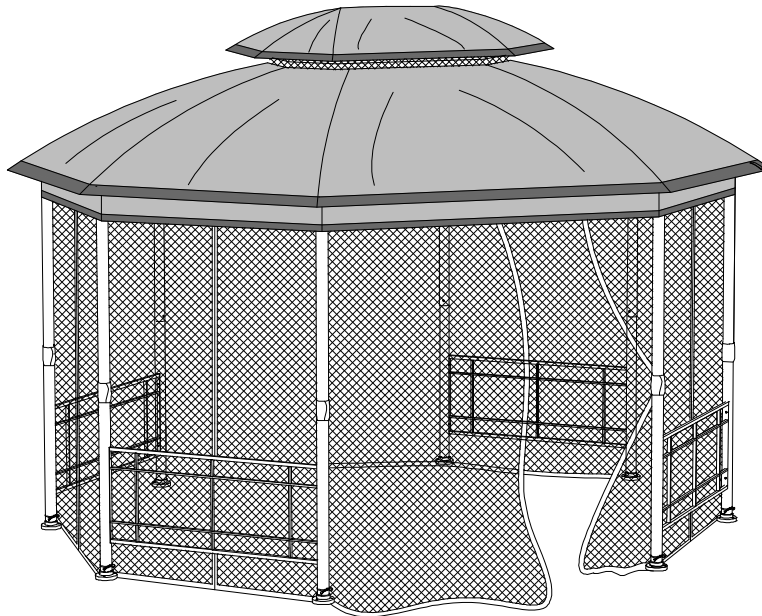

Questions, problems, missing parts? Before returning to the store,
call Hampton Bay Customer Service
8 a.m. - 7 p.m., EST, Monday-Friday, 9 a.m. - 6 p.m., EST, Saturday

1-800-841-1350

HAMPTONBAY.COM

THANK YOU

We appreciate the trust and confidence you have placed in Hampton Bay through the purchase of this gazebo. We strive to continually create quality products designed to enhance your home. Visit us online to see our full line of products available for your home improvement needs. Thank you for choosing Hampton Bay!

Table of Contents

Table of Contents.....	2	Hardware Included.....	5
Safety Information	2	Package Contents	6
Warranty	2	Assembly	8
Pre-Assembly	4	Care and Cleaning	22
Planning Assembly.....	4		

Safety Information

SAVE THESE INSTRUCTIONS

READ ALL INSTRUCTIONS BEFORE USE

To reduce the risk of injury, read the following safety instructions before assembling and using the gazebo:

1. This product is intended for outdoor use only.
2. The product should be assembled on a flat stable surface.
3. Do not assemble the gazebo on unstable surfaces.
4. Ensure the location and clearance of your gazebo is acceptable.
5. The gazebo must be anchored with stakes into the ground for added safety. It is recommended that it should not be permanently attached to a concrete floor or platform.
6. Arrange the necessary manpower when assembling or moving the product.
7. Some parts may contain sharp edges. Wear protective gloves and glasses if necessary.
8. Keep children and pets away while setting up the gazebo.
9. Check all nuts and bolts periodically for tightness. When required, tighten them again.
10. Repairing and replacing parts should be done by a qualified technician.
11. The gazebo is intended for decorative and shade purposes only, and is not designed to withstand harsh weather, including high winds, rain and snow.
12. If the product is not being used for long periods of time (e.g. winter), it should be stored in a clean, dry environment.
13. Do not put a LP or Wood Burning firepit or fireplace inside the product.
14. Do not climb or place heavy objects onto the gazebo roof.
15. Retain the original packaging to store and protect the gazebo during the winter months.
16. Do not use or enter the gazebo if the following conditions exists:
 - a. Visible movement of supports, roofing panels or a sagging roof.
 - b. Unusual noise from the gazebo.
 - c. Deformed roof panels.
 - d. Damaged or missing bolts/fasteners.

(1). Please check your HOA, Local, and State Governments prior to purchasing and assembling this gazebo. These local organizations may require permits and specific requirements for installation.

(2). Maintain your instruction manual for future reference.

(3). Warranty: Please retain you receipt for proof of purchase.

Warranty

2 YEAR WARRANTY

WHAT IS COVERED

This limited warranty is extended to the original purchaser and applies to defects in materials and workmanship of your item provided the item is maintained with care and used only for personal, residential purposes. The item is warranted to be free from defects in material or workmanship for a period of 2 years.

WHAT IS NOT COVERED

We do not reimburse for transportation of delivery costs, or compensate the individual or any outside party for assembling or disassembling the product.

Contact the Customer Service Team at 1-800-841-1350 or visit www.Hamptonbay.com.

Production Number: 2021300015

Pre-Assembly

PLANNING ASSEMBLY

Before beginning assembly of this product, make sure all parts are present. Compare parts with the Hardware Included and Package Contents lists. If any part is missing or damaged, do not attempt to assemble the product. Contact customer service for replacement parts.



NOTE: Tools and protective articles below are not provided.

TOOLS REQUIRED

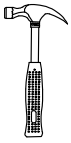

Hammer



Ladder



Cordless drill

IMPORTANT

This product requires at least two people for assembly. Approximate assembly time: 2 hours.

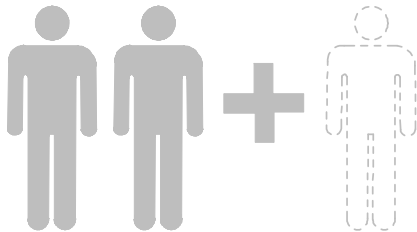

Pre-Assembly (continued)

HARDWARE INCLUDED



NOTE: Hardware not shown to actual size.

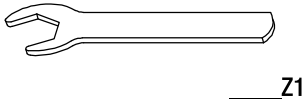
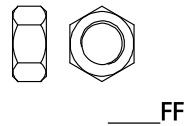
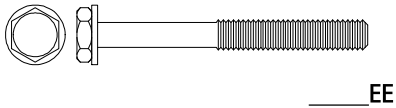
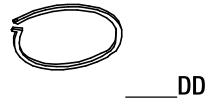
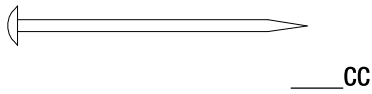
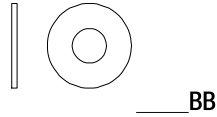
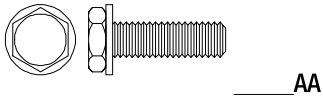

Part	Part Number	Description	Quantity
AA	H100010057	Bolt M6*20	56+3
BB	H050030001	Flat Washer M6	2
CC	H070010003	Stake Φ 8*180	16
DD	P005100264	Ring	52+3
EE	H100010058	Bolt M6*50	2+1
FF	H040010004	Nut M6	2+1
Z1	H090010017	Wrench M6	2

Pre-Assembly (continued)

PACKAGE CONTENTS

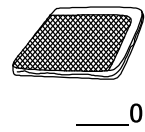
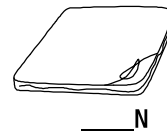
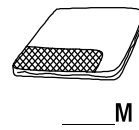
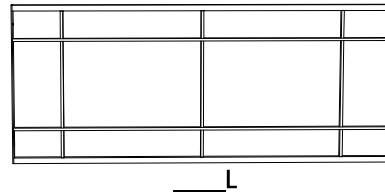
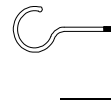
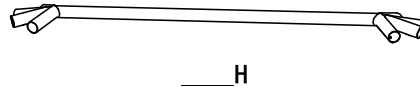
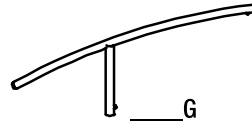
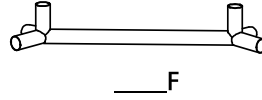
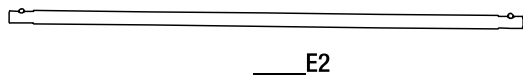
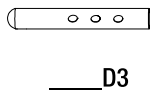
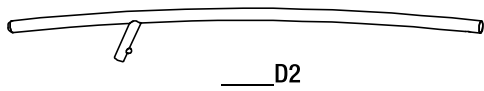
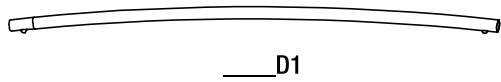
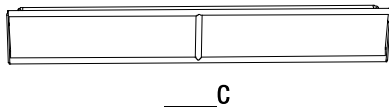
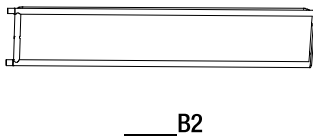
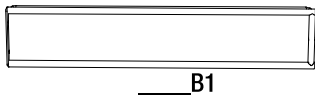
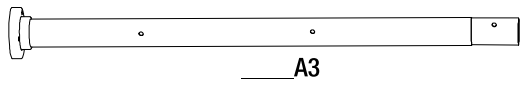
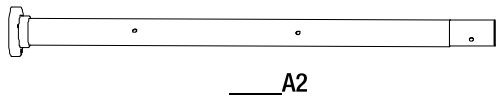
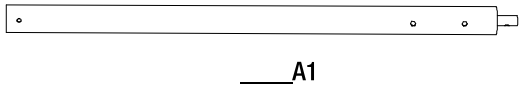

Pre-Assembly (continued)

Part	Part Number	Description	Quantity
A1	P000200224	Top Post	8
A2	P000200338	Bottom post 1	4
A3	P000200409	Bottom post 2	4
B1	P000401120	Left long screen	2
B2	P000401121	Right long screen	2
C	P000400709	Short screen	6
D1	P000600366	Upper oblique beam	8
D2	P000600788	Bottom oblique beam	8
D3	P005700788	Adjust tube	8
E1	P000400288	Large roof short tube	2
E2	P000400455	Large roof long tube	2
F	P000500093	Large roof connector	4
G	P000600232	Small roof oblique beam	8
H	P000500083	Small roof connector	1
I	P005800001	Hook	1
L	P006200016	Panel	4
M	P001100483	Small roof canopy	1
N	P001100484	Large roof canopy	1
O	P001200051	Mosquito netting	1

Assembly

1 Assembling the Post

- Insert the bottom post (A2&A3) to the top post (A1) using bolts (AA). Tighten with the wrench (Z1).



NOTE: To avoid destroying the finish, do not put the parts on the ground directly.

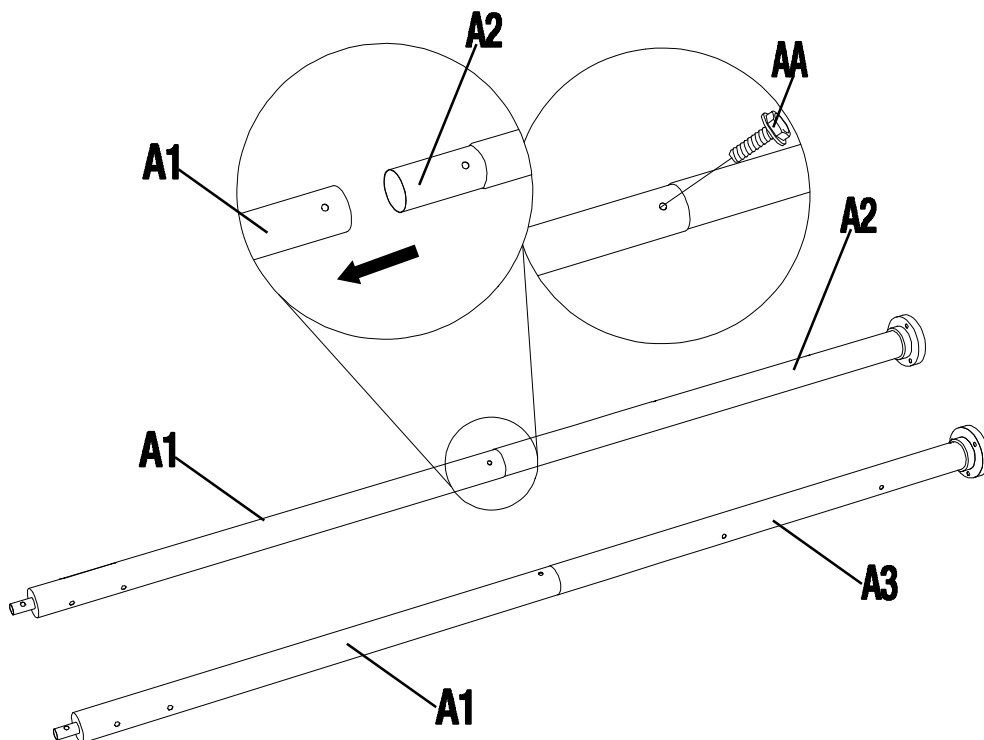
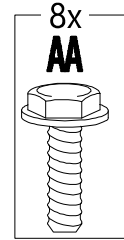
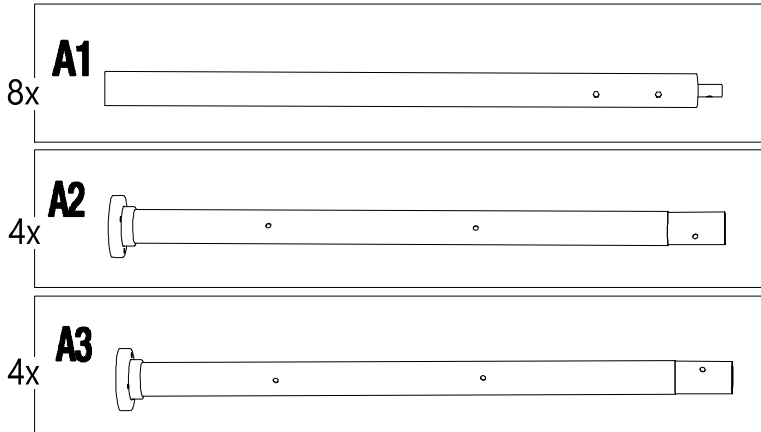

Assembly (continued)

2 Assembling the 4 sets of Short Screens and Panels

- Assemble the short screens (C) to the top posts (A1) using bolts (AA). Assemble the panels (L) to the bottom posts (A2&A3) using bolts (AA). Tighten the bolts using the wrench (Z1).



NOTE: Please note there are total six of short screens (C) for the whole gazebo, but you only need to assemble four of them at this step. The remaining two will be assembled in Step 4. Also ensure the small holes on the top of the posts (A1) are oriented correctly.

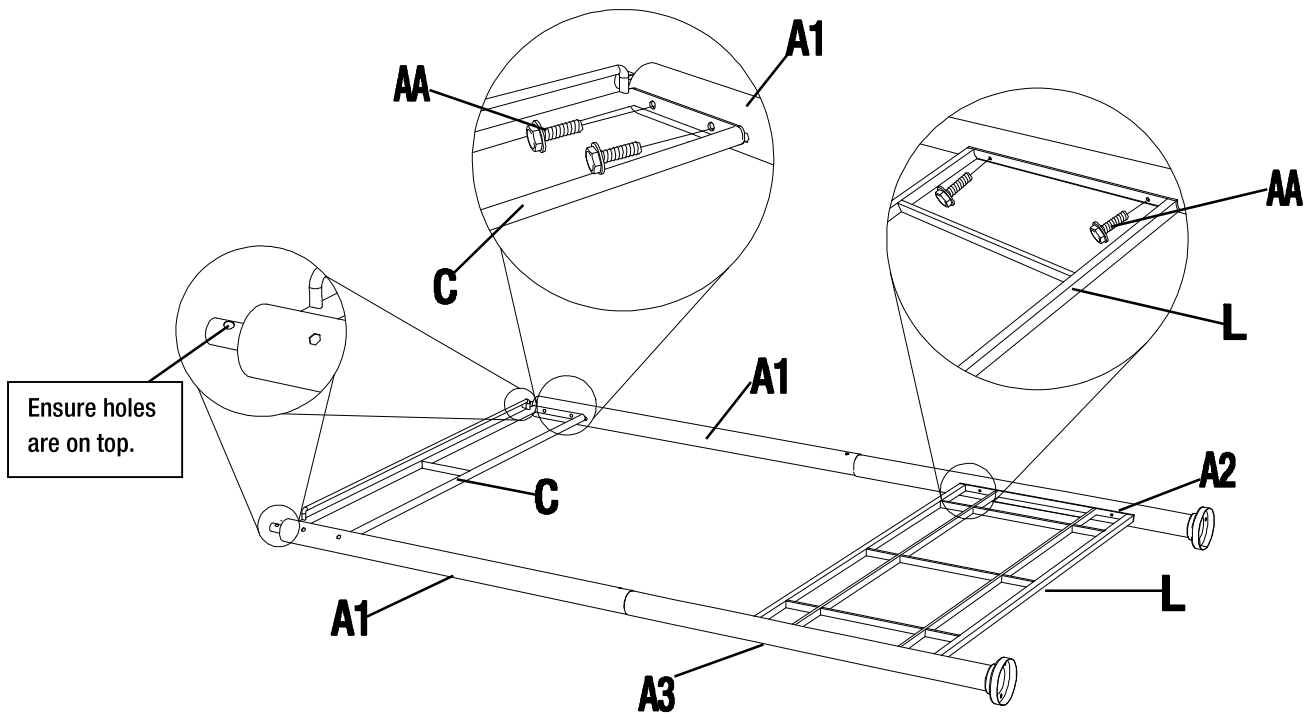
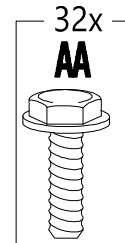
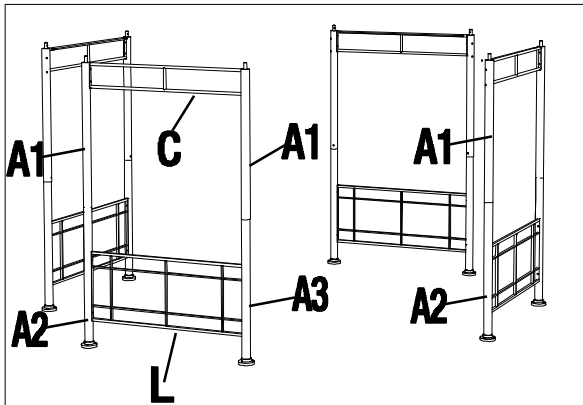
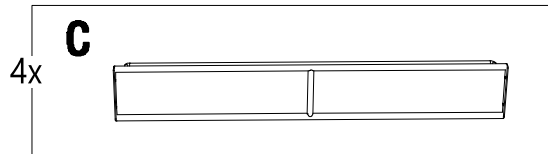
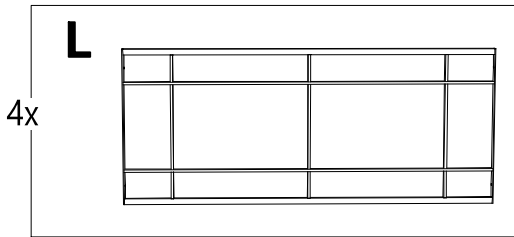

Assembly (continued)

3 Assembling the Long Screens

- Connect the left long screen (B1) with right long screen (B2) using a bolt (EE), washer (BB) and nut (FF). Tighten using the wrench (Z1).



NOTE: To avoid destroying the finish, do not put the parts on the ground directly.

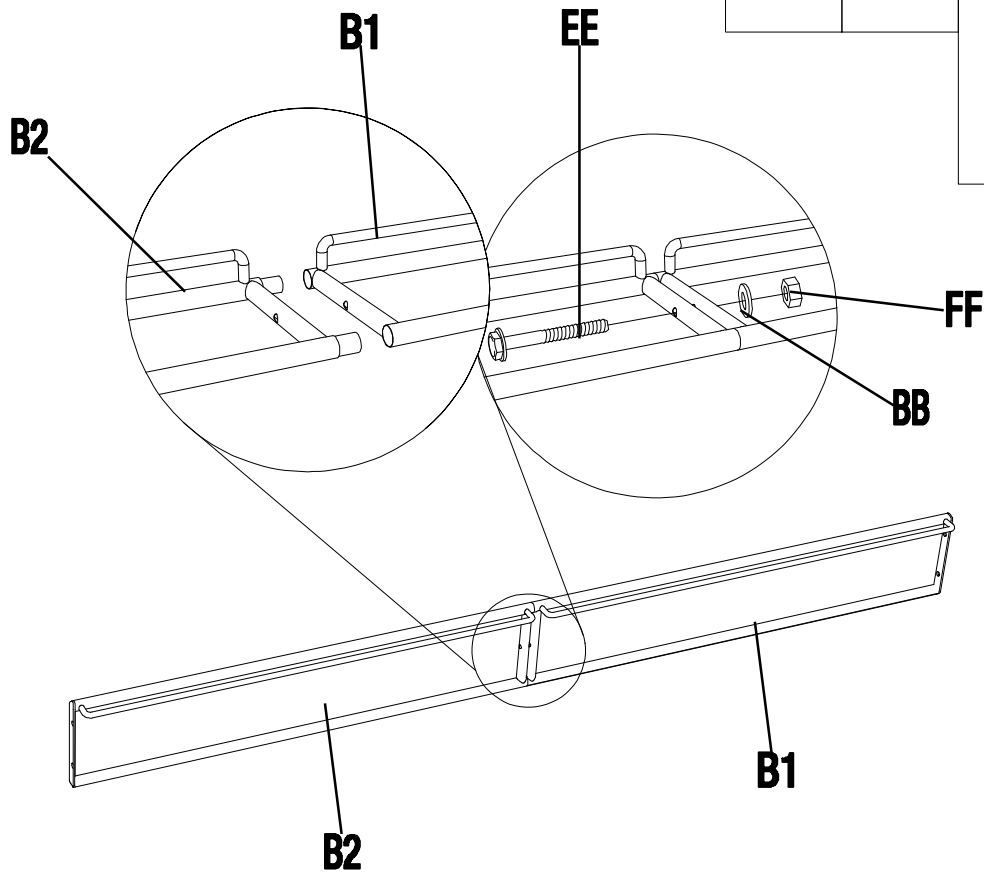
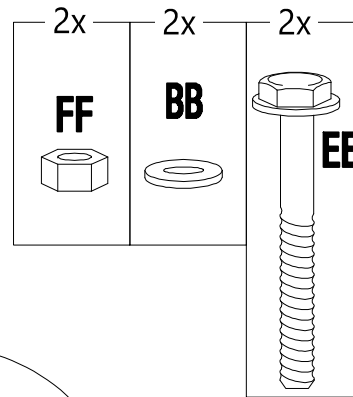
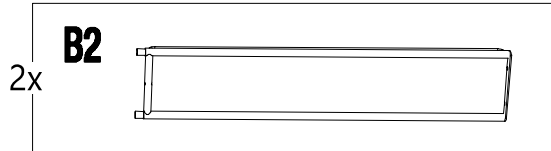
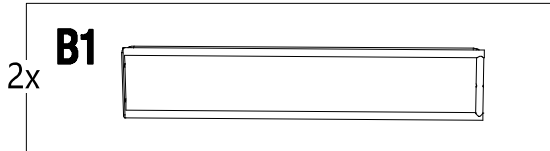

Assembly (continued)

4 Attaching the assembled Long Screen and Short Screen

- Attach the assembled long screen (B1&B2) and the remaining two short screens (C) to the top posts (A1) using bolts (AA). Tighten using the wrench (Z1).



NOTE: To avoid destroying the finish, do not put the parts on the ground directly.

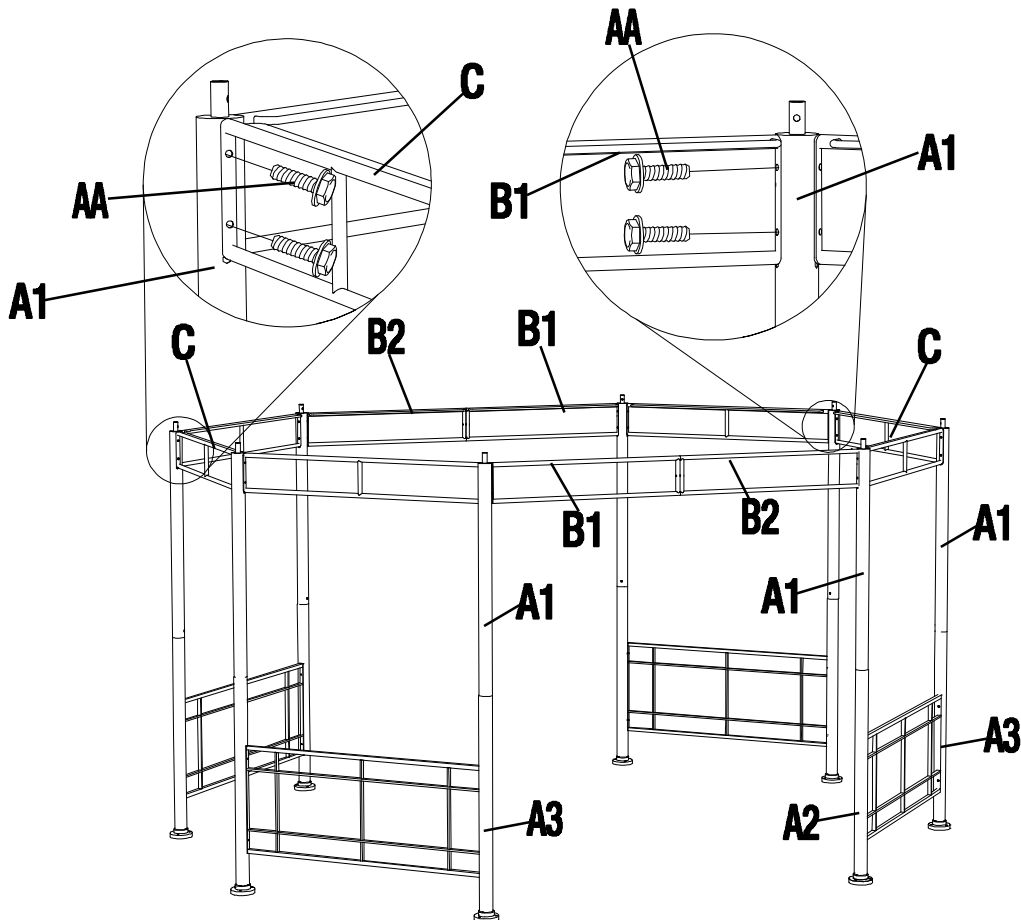
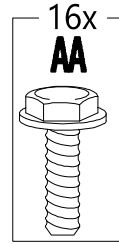
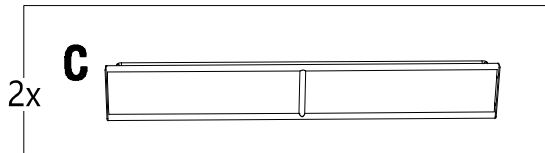
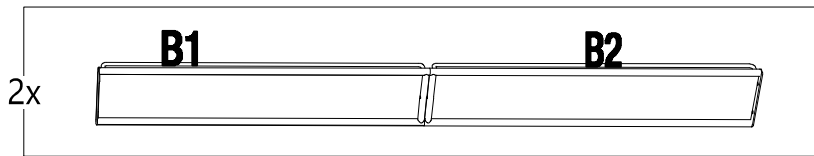

Assembly (continued)

5 Assembling the Large Roof Frame

- Lock the large roof tubes (E1&E2) and large roof connectors (F) together until they click into place.



NOTE: To avoid destroying the finish, do not put the parts on the ground directly.

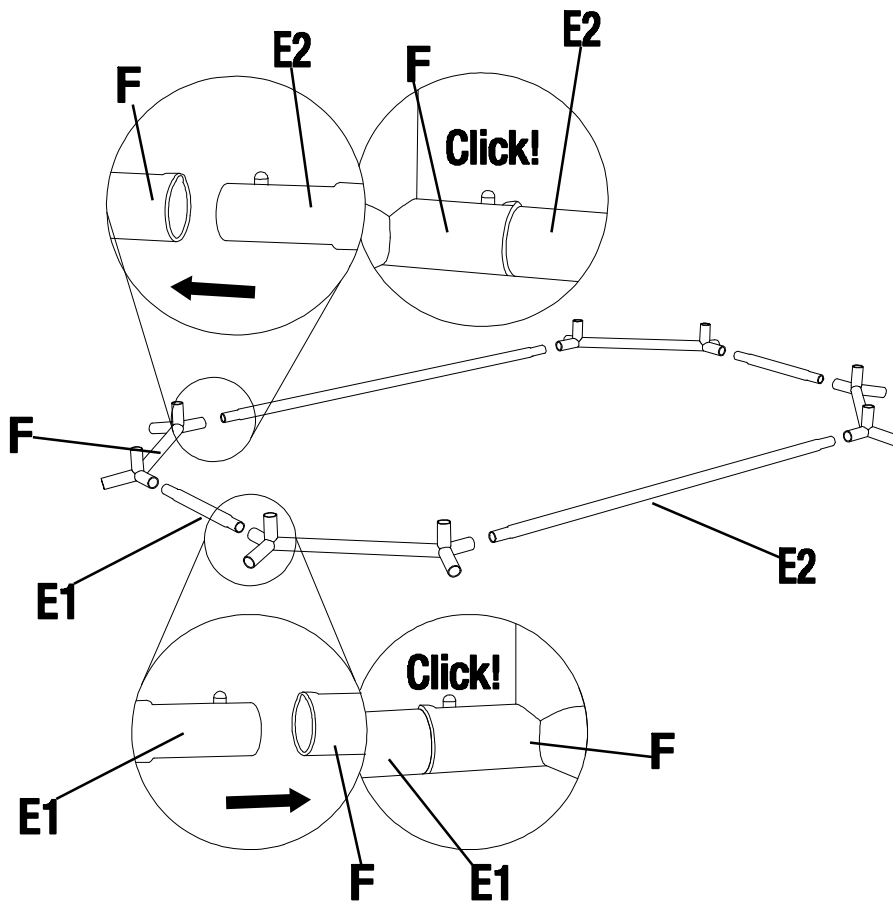
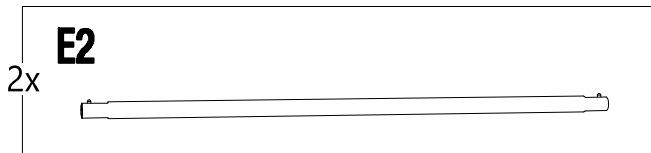
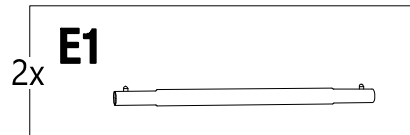
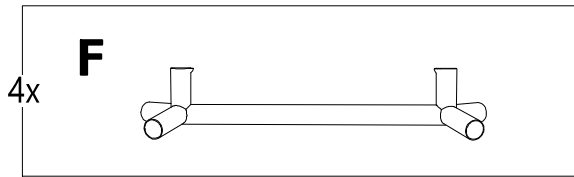

Assembly (continued)

6 Assembling the Upper Oblique Tube and Bottom Oblique Tube

- Lock each upper oblique tube (D1) and the bottom oblique tube (D2) together until they click into place. Then lock the end of each bottom oblique tube (D2) and the adjust tube (D3) together until they click into place.



NOTE: To avoid destroying the finish, do not put the parts on the ground directly.

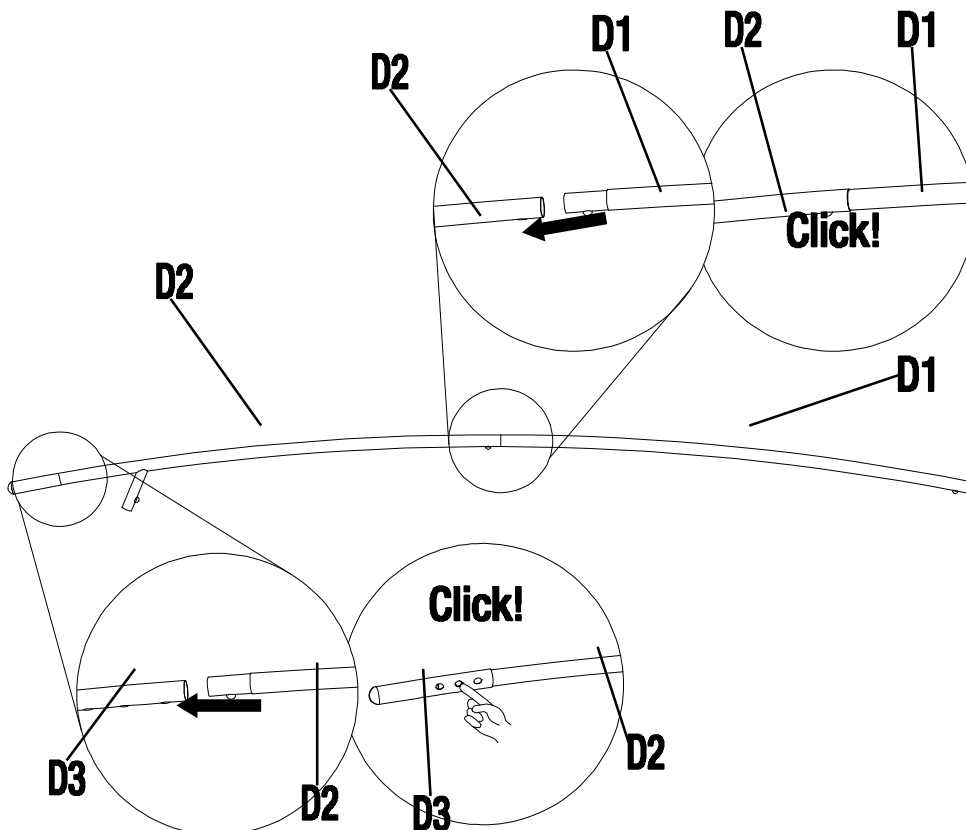
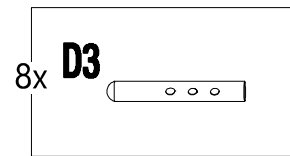
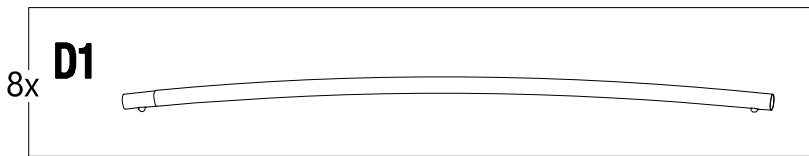

Assembly (continued)

7 Attaching the Big Roof

- Lock the assembled upper oblique beams (D1) and the large roof connector (F) together until they click into place. Then lock the assembled bottom oblique tubes (D2) and the upper posts (A1) together until they click into place.



NOTE: To avoid destroying the finish, do not put the parts on the ground directly.

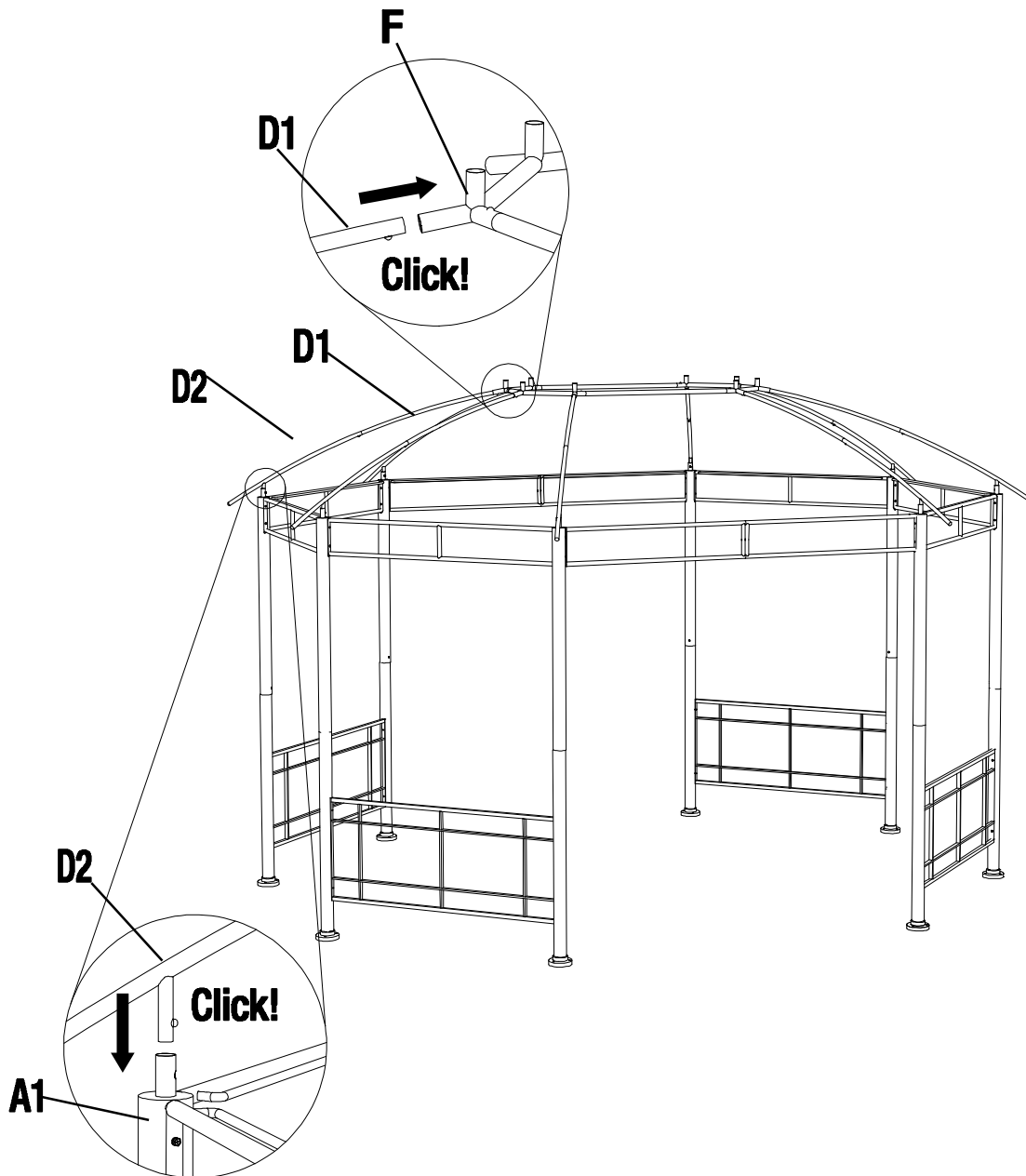

Assembly (continued)

8 Attaching the Large Roof Canopy

- Put the large roof canopy (N) on the assembled big roof, do not tighten the canopy.



NOTE: To avoid destroying the finish, do not put the parts on the ground directly.

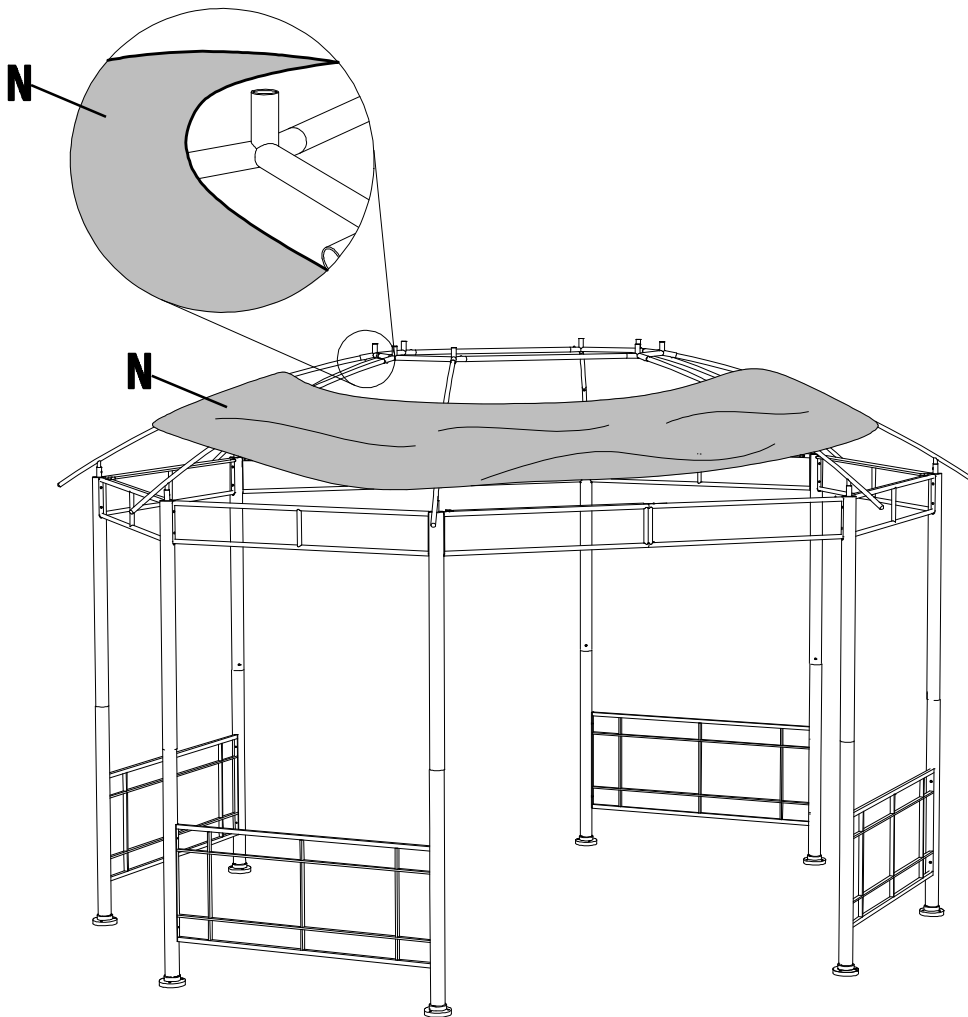
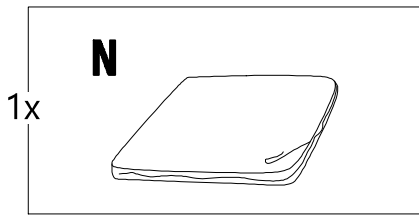

Assembly (continued)

9 Assembling the Small Roof

- Lock the small roof oblique beams (G) to the small roof connector (H) until they click into place.



NOTE: To avoid destroying the finish, do not put the parts on the ground directly.

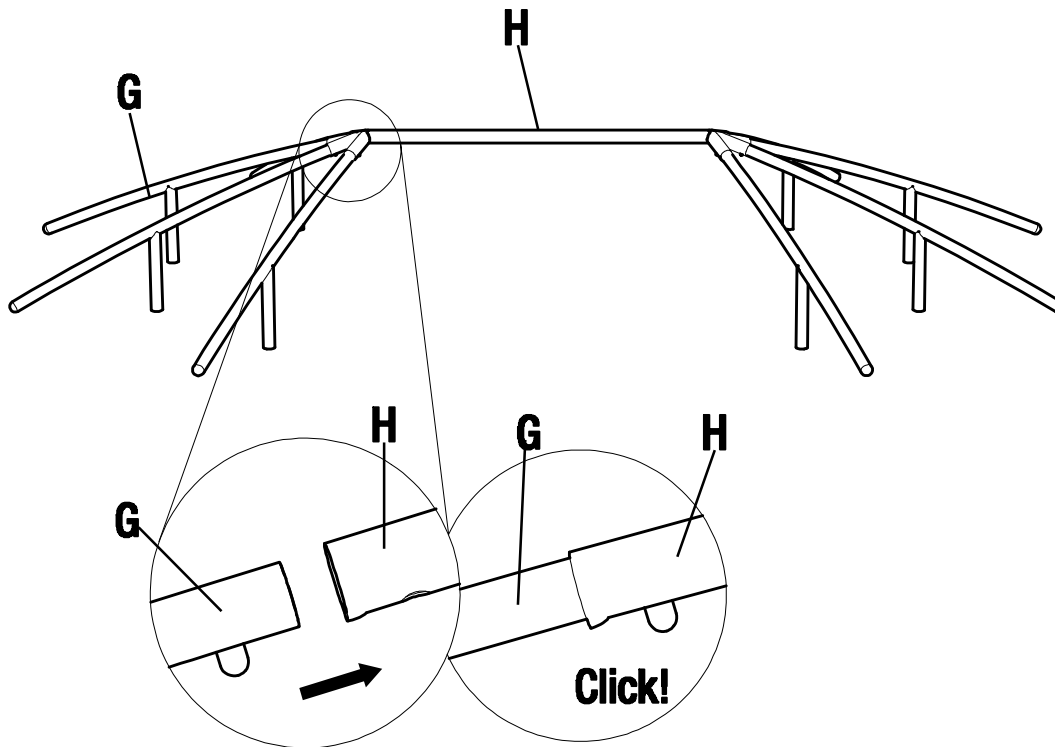
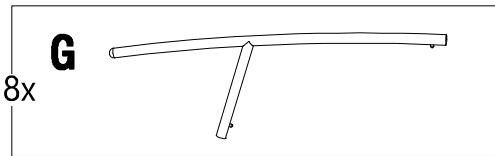
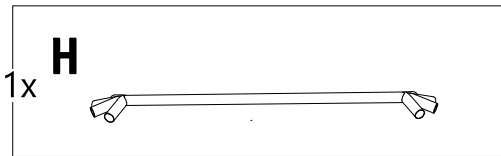

Assembly (continued)

10 Attaching the Small Roof Canopy

- Put the small roof canopy (M) on the small roof and align the corners.



NOTE: To avoid destroying the finish, do not put the parts on the ground directly.

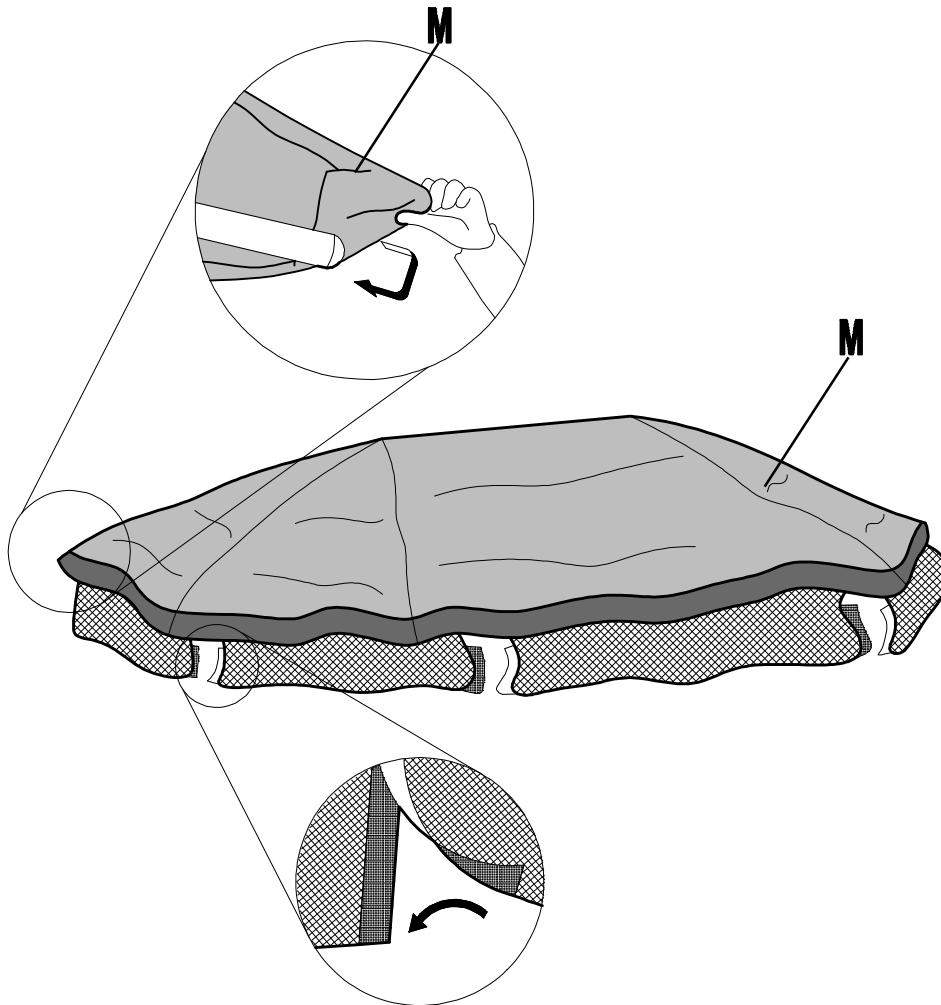
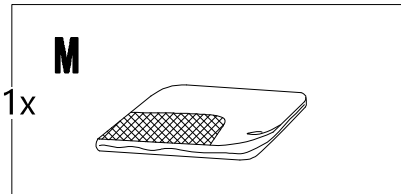

Assembly (continued)

11 Attaching the Assembled Small Roof and Hook

- Attach the assembled small roof on the big roof, lock the small roof oblique beam (G) and the large roof connector (F) until they click into place. Screw the hook (I) into the small roof connector (H).



NOTE: To avoid destroying the finish, do not put the parts on the ground directly.

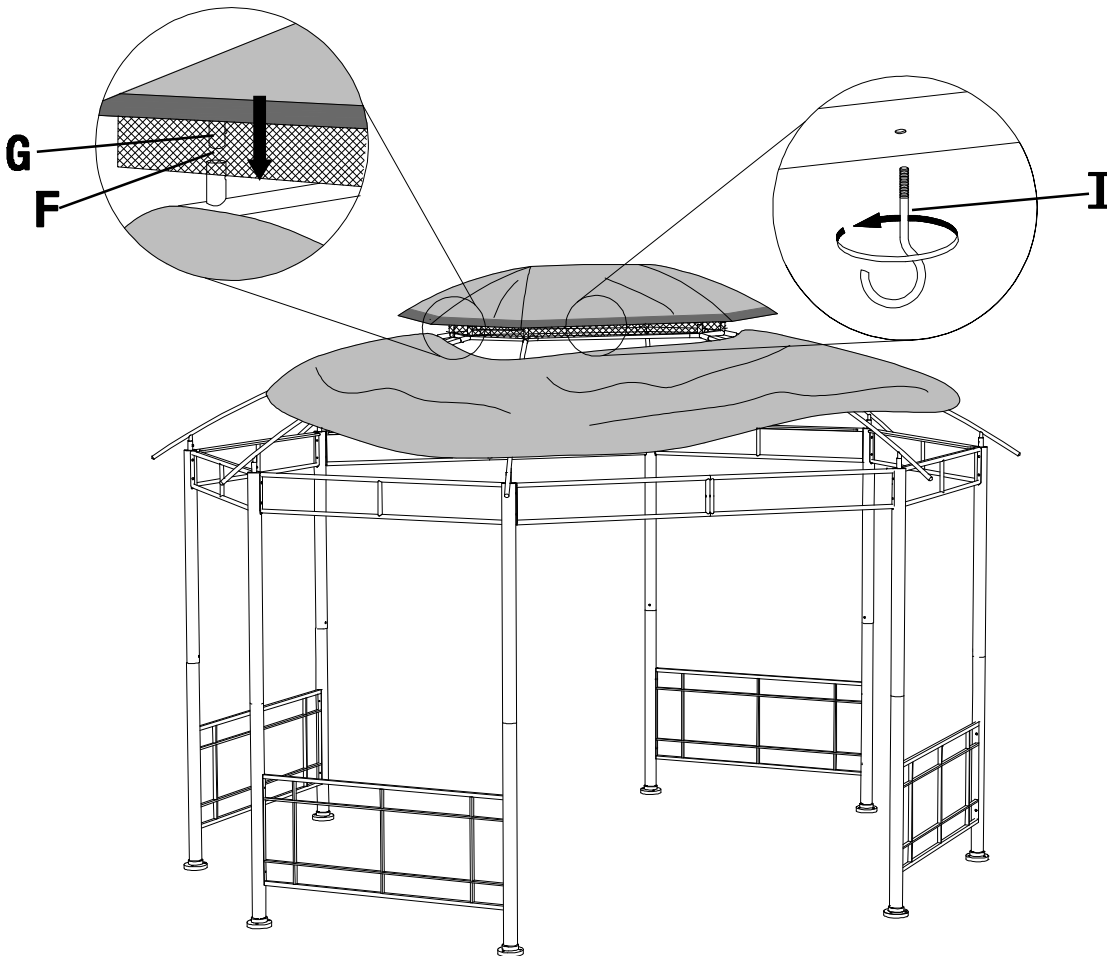
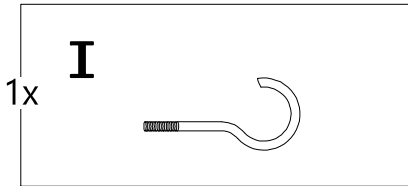

Assembly (continued)

12 Spreading the Big Canopy

- Spread the large roof canopy (N), attach the corner (without handle) to the adjust tube (D3), then attach the final canopy corner (with handle) to the adjust tube (D3).



NOTE: To avoid destroying the finish, do not put the parts on the ground directly.

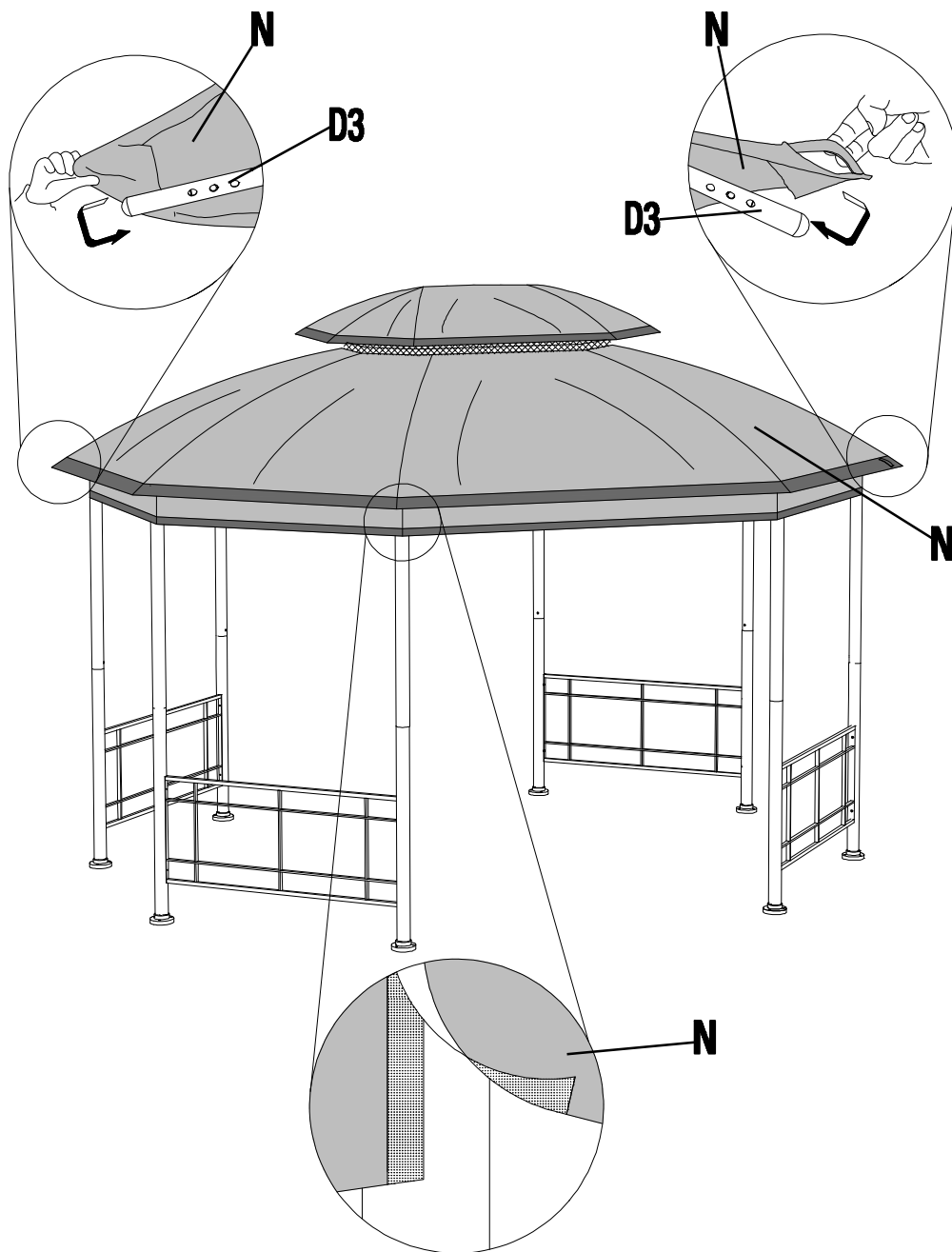

Assembly (continued)

13 Attaching the Mosquito Netting

- Hang the mosquito netting (O) to the netting tube with rings (DD).



NOTE: Ensure you match the zippers for the different panels as shown.

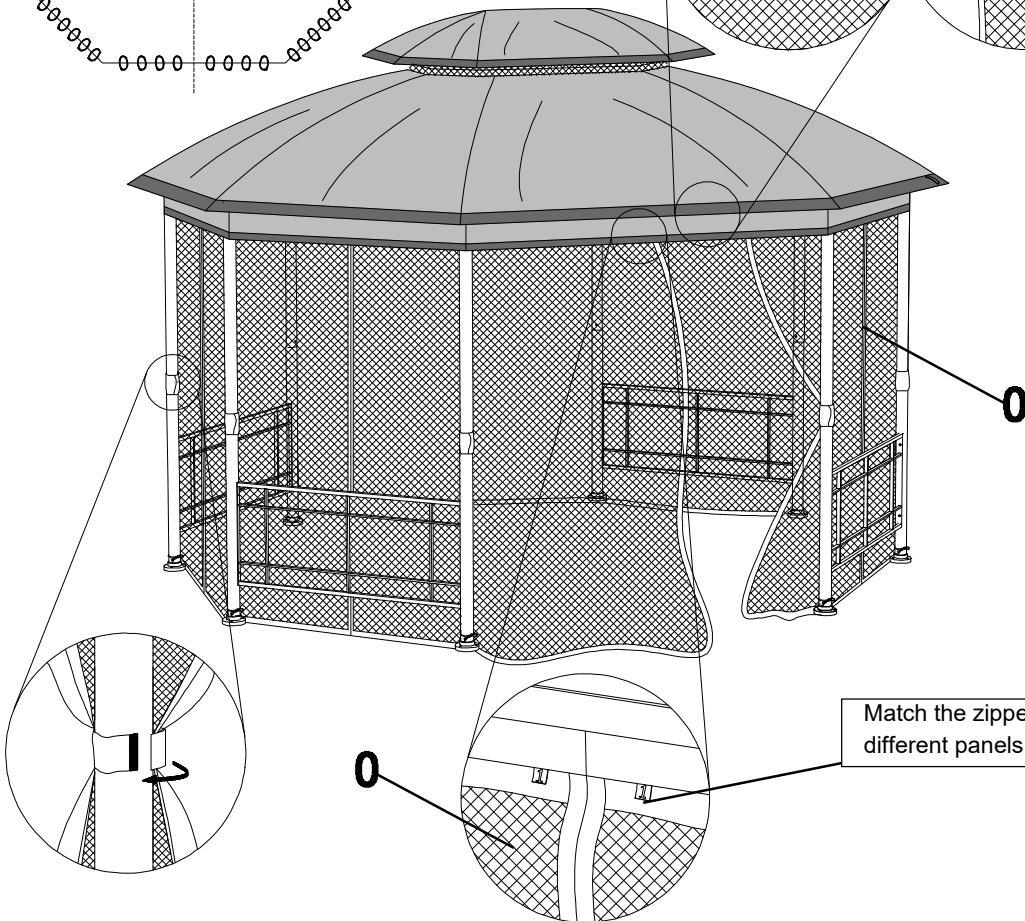
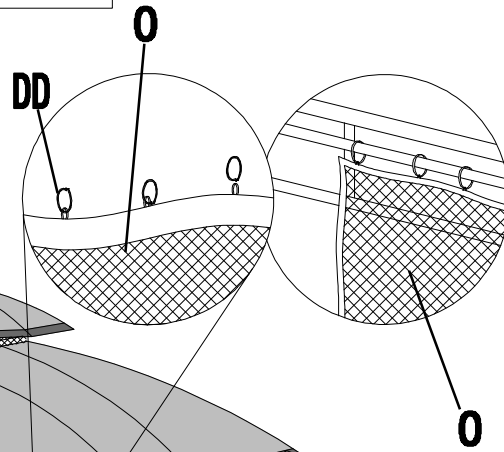
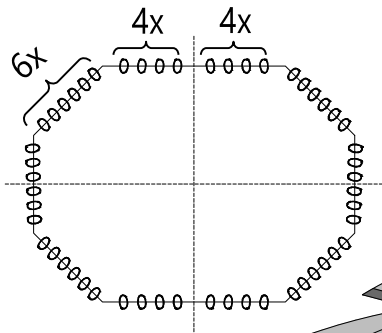
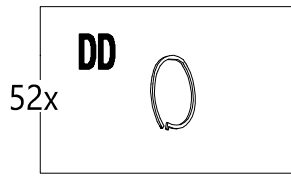
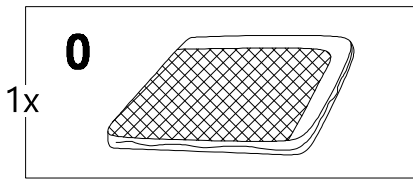

Assembly (continued)

14 Securing the Gazebo

- Secure the assembled gazebo to the lawn with the stakes (EE).
- It is recommended for anchoring on wood or concrete surface for more stability using setscrews (Purchased separately).



NOTE: To avoid destroying the finish, do not put the parts on the ground directly.

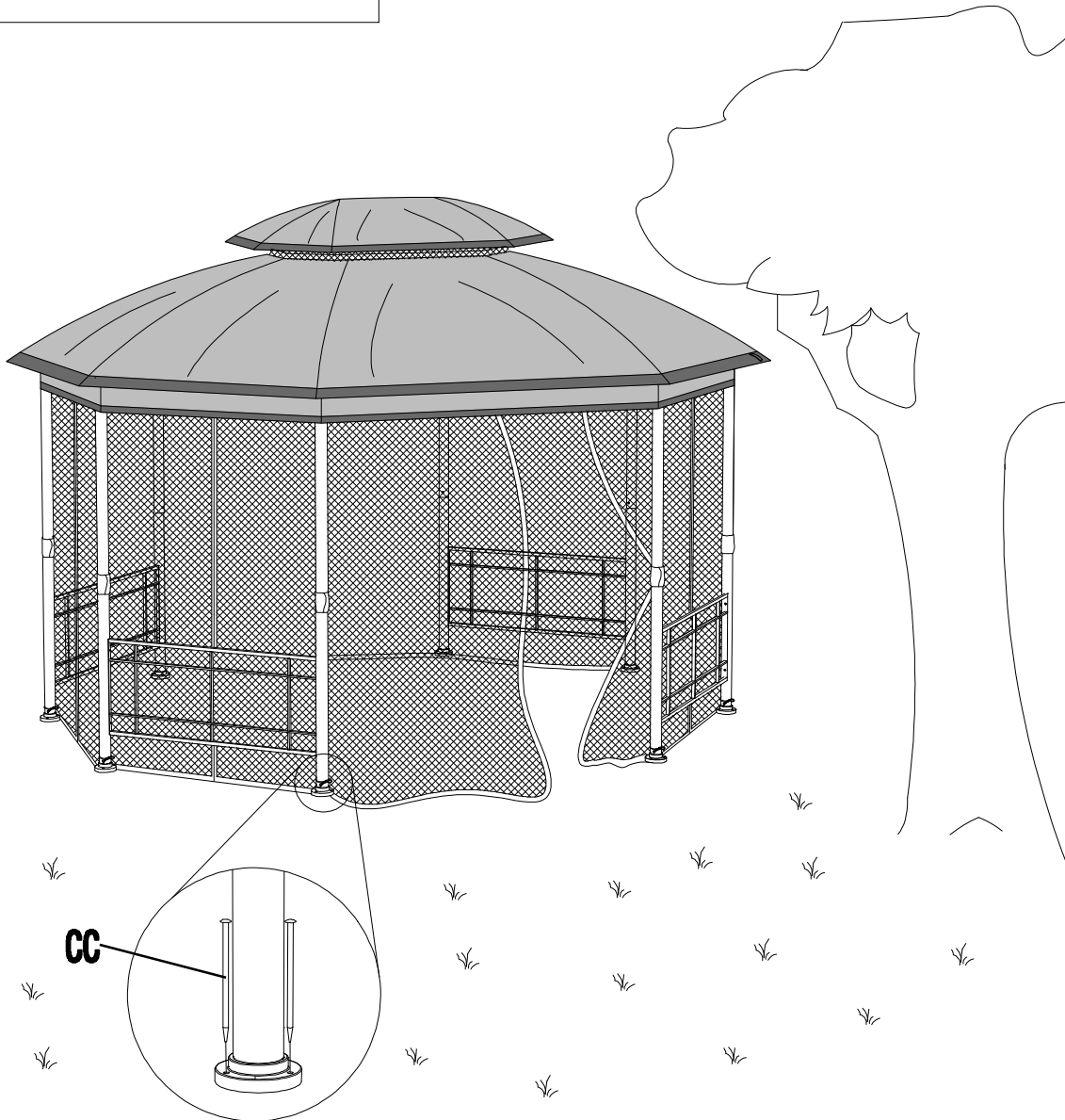
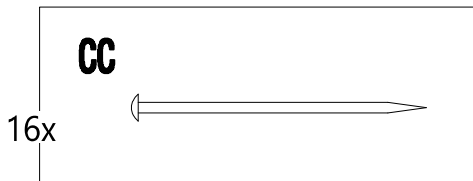

Care and Cleaning

- Check all screws and nuts periodically for tightness, fastening them again as required.
- Disassemble the gazebo in the reverse order of the assembly steps. Always disassemble the gazebo completely. A partially disassembled gazebo is not stable enough to resist wind and bad weather, and therefore can be damaged and/or cause damage.
- Clean the gazebo with mild soap and water. Rinse thoroughly and wait until the product is dry before reassembling it.
- Snow must be cleared off regularly during snowy days. Remove the snow at the roof top when it is thicker than 2 inches. In order to avoid damage, use a plastic snow rake to remove excessive snow and ice buildup from roof and keep away from falling debris.
- Do not use bleach, acid, or other abrasive cleaners on the canopies or frame parts.
- Steel components for this gazebo are treated with rust inhibiting paint to prevent from rusting. However, due to the nature of steel, surface oxidation (rusting) will occur if these protective coatings are scratched. This is not a defect and thus not covered by the warranty. To minimize this condition, it is recommended to use care when assembling and handling the product to prevent scratching the paint. Should any scratching or damage occur, it is recommended to cover the scratch immediately with rust inhibiting paint not included. Surface rust can also be easily removed with a very light application of regular cooking oil or WD-40. If surface oxidation (rusting) occurs and if no measure is taken to prevent this, the oxidation may start dripping onto deck or patio and cause damaging stains, which may be difficult to remove. This can be prevented if the above-mentioned measures are taken to keep the product from oxidizing.
- Keep instruction manual for future reference.
- Keep the original packaging to store the gazebo.

HAMPTON BAY[®]

Questions, problems, missing parts? Before returning to the store,
call Hampton Bay Customer Service
8 a.m. – 7 p.m., EST, Monday – Friday, 9 a.m. – 6 p.m., EST, Saturday

1-800-841-1350

HAMPTONBAY.COM

Retain this manual for future use.
