

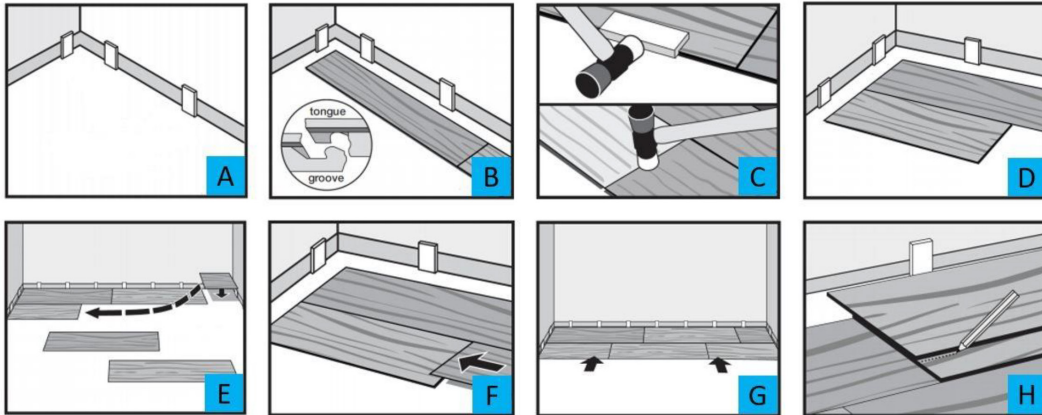

**Please Carefully Read All Instructions Before You Begin Your Installation. Improper Installation Will Void The Warranty.**

1. Read enclosed detailed installation instructions before beginning install.
2. A flat subfloor is a must!
3. Proper moisture testing is a must!
4. Proper expansion around all permanent structures is a must!
5. Molding, trim, transition, and finish pieces must not prevent the floor from floating.
6. Failure to follow installation instructions will void warranty.
7. No acclimation is required under proper conditions.



Always check flooring planks for defects such as chips and color variations under good light conditions. Check that groove are free of debris. Use planks from multiple boxes during installation to insure random pattern variation.



**WARNING:** Drilling, sawing, sanding, or machining wood products can expose you to wood dust, a substance known to the state of California to cause cancer. Avoid inhaling wood dust or use a dust mask or other safeguards for personal protection. For more information go to [www.P65Warnings.ca.gov/wood](http://www.P65Warnings.ca.gov/wood)

## NO ACCLIMATION REQUIRED

No acclimation is required under proper conditions. However, if the flooring is exposed to temperatures less than 40° F (5° C) or more than 95° F (35° C) and/or if the flooring is exposed to relative humidity below 35% or above 70%, flooring must be conditioned by spreading them out in unopened cartons, not stacked, in the room where they will be installed, for minimum 12 hours under the recommended temperature and humidity ranges specified in this installation guide.

The area in which the flooring is installed must remain \*climate controlled with the temperature between 65-85°F (18-25°C) for the life of the product.

\* **Lofeproof's Everlife SPC flooring may be installed in a vacation home, three-seasons room, etc., with a temperature between 55-95° (13-35°C) at least 48-hours before and during the installation, even if temporary temperatures must be taken. Thereafter, the temperature cannot fall to below 40°F (5°C) or higher than**

**95°F (35°C) and RH must maintain between 35-70%. In these installations, you must use transition moldings at doorways and in any span greater than 40' in any direction, as is true in light commercial and radiant heat installations.**

Installation spanning greater than 40 feet in length or width must have a T-molding installed across the width of the room, archway or at the beginning of the hallway to provide proper expansion space. Doorways of less than 4 feet must always have a T-molding or other transition molding regardless of floor length or width. While this flooring can be installed above, on, or below grade, below grade must not have a sump pump or floor drains.

This product is a floating floor and should NOT be secured to the floor. Do not install fixed objects, such as cabinets, on top of the flooring unless it is fully adhered and do not fasten trim/molding/transition pieces directly to the floor.

## REQUIRED TOOLS AND SUPPLIES

- Saw
- Safety glasses
- 1/2" spacers
- Utility knife
- Straight edge ruler or T-square
- Pencil
- Tape measure
- Adhesive Tape
- Soft Rubber Mallet
- Dust Mask or Respirator

**If existing baseboard molding is difficult to remove, Quarter Round molding likely will be required to cover the expansion space need between flooring and baseboard.**

## SUITABLE TYPES OF FLOORS AND FLOOR PREPARATION

The sub floor must be **flat, dry, and clean**. Carpet staples or any/all adhesive residue must be removed and floor must be clean to ensure proper installation. All wooden subfloors must be structurally sound and must be installed following the American Plywood Association's (APA) and the manufacturer's recommendations. If it is uncertain that any old adhesive residue may cause issues, use **Lifeproof's** MS005 Adhesive Encapsulator.

To check for flatness, hammer a nail into the center of the floor. Tie a string to the nail and push the knot against the floor. Pull the string tight to the farthest of the room and examine the floor for any high/lows relative to the string. Subfloors must be flat to 1/8" per 6' (3mm per 0.92 meter). Any areas in excess of the flatness specification must be sanded down or filled with an appropriate leveler.

This product can be installed over most existing floors including wood, non-cushioned vinyl or linoleum, and ceramic/porcelain tile if the existing flooring is intact and properly secured to the subfloor. If installing over ceramic/porcelain tile, grout lines in excess of 1/16" (0.625) must be filled with a Portland based skim coat/floor leveler according to the manufacturer's guidelines.

**Warning: This product should not be installed over carpet. Installation over carpet will void the warranty.** If an additional underlayment beyond what is already attached to the product is required, an **Lifeproof** approved underlayment should be used (Abatec or Mititec). When installed in rooms with direct sunlight, during the peak hours of sunlight, the use of blinds/shades or drapes to avoid prolonged direct sunlight period is recommended.

This product is waterproof but is not a moisture barrier. The product can withstand topical water and water penetration for us to 16 hours without being damaged. However, water leaking over or around the outer edges of the flooring can damage a wood subfloor and breed mold/mildew growth on subfloor and walls. This is not considered a defect in the flooring.

## INSTALLATION

- Set spacers to allow an expansion gap of 1/2" (10mm) around the perimeter of the subfloor for movement or product expansion. Do not remove the spacers until the installation is complete. The expansion gaps should be covered by molding (Figure A).
- Measure the length of the room in inches. Divide it by the length of the planks. If the resulting number is less than 8", you will need to cut your first plank accordingly to avoid having planks that are less than 8" on the opposite end of the room.

**Note:** Use saw to cut plank to size. If cutting with a jig saw, the wood surface should be turned down. If cutting with a hand saw, the wood surface should be face up.

- Installation should start in a left-hand corner and proceed from the wall with the tongue facing the wall. Position the first plank 6" (15.2cm) from the starting wall but not up against the spacers (Figure B). The entire row will be moved against the spacers in a later step.
- Interlock the next plank at the end joint of the first plank by inserting the tongue into the groove of the adjoining planks.

Moisture in concrete subfloors can create high moisture vapor emission levels, hydrostatic pressure, and high alkalinity levels. This combination is highly corrosive and damaging to flooring, over time. To avoid this, ensure that concrete subfloors are constructed according to the American Concrete Institution's guidelines (ACI's 302.2 Guide). To check current conditions, an RH test using in situ Probes (ASTM F2170) is necessary. If the level of hydrostatic pressure is over 90% RH, or will be above 90% RH during the life of the slab, our warranty requires moisture mitigation, such as the use of a moisture barrier, like a 6-mil poly film or **Lifeproof** underlayment, or you must use **Lifeproof** adhesive designed to support 95%+ RH. There also is calcium chloride testing (ASTM F1869) but the in situ Probe (ASTM F2170) is the preferred test. Lightweight concrete (minimum density of 90 lbs. per cubic foot) is acceptable if installed according to the manufacturer's instructions and primed with **Lifeproof's** MS003 primer.

**Note: New concrete needs to cure for at least 60 days before installing flooring materials.**

If considering **Radiant heat**, only Hydronic radiant heat is allowed. The heating components must have a minimum of 3/8" separation from the product. System must be operational for a minimum of two weeks prior to installation. Five days prior to installation, the temperature should be reduced to 65°F (18°C). After installation, the temperature can be raised gradually (5°F per hour) to a maximum operation temperature of 85°F (29°C). An in-floor thermostat is recommended to avoid overheating and a transition strip must be used for any installation longer than 40' in any direction. It is also suggested to use T-Molding in doorways.

**Warning:** Electric heating mats that are not embedded into the subfloor are not recommended for use underneath the flooring. **Using electric heating mats that are not embedded and applied directly underneath the flooring will void the warranty.**

Square the joints by tapping the long edge with the profiled tapping block and soft-faced hammer. Next, lightly tap down on top of the plank at the short joint with the soft-faced hammer (Figure C). Continue this method to finish the first row. Cut the last piece of the row to fit, and allow for the 1/2" (10mm) expansion gap. Install as above.

- To install the second and remaining rows, cut the first plank of the second row to two-thirds its length or make sure there will be at least an 8" (20.3cm) stagger between end joints. Angle the long tongue edge of the plank into the long groove edge of the first plank. Drop and lock the end joints together (Figure D). Make sure there are no gaps and, if necessary, tap along the long groove edge using the soft-faced hammer and profiled tapping block to ensure a tight fit (Figure C). Do not tap the short end into place if the long joint is not properly engaged, as doing so can cause damage to the tongue and groove.

**Note:** When starting a new row, you can use the cut piece from the previous row (Figure E), as long as it is more than 8" (20.3cm) and the stagger between seams still is greater than 8" (20.3cm).

## INSTALLATION CONTINUED

- Attach the second plank by connecting the long side to the first row and sliding it up to the short end of the first plank (Figure F). Check that the long joints of the planks are properly engaged and then press the short joint into place with your fingers.
- Continue to square the joints by tapping the long edge with the profiled tapping block and soft-faced hammer. Then, lightly tap down on top of the plank at the short joint with the soft-faced hammer (Figure C). Continue installing the remainder of the row in this fashion.
- After installing the last piece of the second row, slide the entire assembly against the spacer on the starting wall, maintaining the required 1/2" (10mm) expansion gap (Figure G).
- Install remaining rows, one after the other, and maintain the required 8° (20.3cm) stagger throughout the install. Tap and square each plank as in the previous steps.
- To install the last row, most often, the entire length of the last row will need to be cut so that it is narrow enough to fit the remaining space. Cut the first plank of the last row to length (if necessary to follow stagger pattern). Place directly on top of the previously installed row. Then, take another plank and place it against the wall on top of the plank to be cut for width. Mark the plank (length-wise), cut to size (Figure H). Remember to allow for the 1/2" (10mm) expansion gap against fixed objects.
- Install the plank with the cut side always facing the wall. Use a pull bar to lock the long edges together. Do not use the pull bar on the short edges. Continue to cut and install remainder of the planks in the last row.
- Door Frames and heating vents also require expansion room. Cur the planks to the correct length. Place the cut plank next to its actual position, use a ruler to measure the areas to be cut out and mark them. Cut out the marked points allowing the correct expansion distance on each side. T-molding is suggested in all doorways.
- To trim doorframes, turn a panel upside down to use as a height guide. Using a handsaw, cut door frames to the necessary height so that the planks slide easily under them.
- To make holes for pipes, measure the diameter of the pipe and drill a hole that is 7/8" (20mm) larger into the plank. Saw the plank into two pieces perpendicular to the length and bisecting the previously drilled hole. Then lay the pieces in place around the pipe.
- To finish the perimeter of the room, install quarter round molding using finishing nails. Nail quarter round directly into the baseboard not the flooring. Do not install over multiple layers of underlayment.

## MAINTENANCE

Dust-mop or broom can be used for daily maintenance. When necessary, clean with a MOIST cloth or mop and a neutral PH cleaner – heavy use of detergent cleaners will leave a residue and, over time, lead to a cloudy film.

## TIPS

- Always use felt tip protectors on all furniture legs/feet, and regularly clean any gathered dirt/grit from the pads
- Walk off mats should be placed at all exterior entrances to protect the Flooring from soil, grit, deicers, asphalt sealers, and other contaminants capable of damaging the Flooring. Suitable walk off mats should contain both soft and firm fibers to facilitate removal of wet or solid contaminants from shoe soles. An extra set of walk off mats should be available for each entrance so walk off mats can be replaced and cleaned weekly during routine maintenance or more often depending upon site and weather conditions.

## WARRANTIES

**Joint Integrity:** During the period of the warranty the locking system will not fail when properly installed and maintained according to the manufacturer's instructions. Installed flooring must remain climate controlled with the temperature of 55-95°F (13-35°C) for the life of the produce, with the herein listed exceptions.

**Manufacturing Defect:** During the period of the warranty, this product will be free from manufacturing defects.

**NEVER USE** floor polish or floor cleaning wax, oils, soaps, etc. These products can damage and/or leave a film on the flooring. This is not a flooring defect.

- Warning:** Never use vinyl/latex/rubber backed protective mats
- Area rugs are recommended
  - Keep pet nails trimmed
  - Sharp shoe-heels (e.g. high-heels) may dent the floors
  - Never slide furniture across a floor without pads
  - Keep floors clean
  - For wet areas such as bathrooms, caulk/completely seal the perimeter of the floor with a flexible silicon caulk

**Water Proof:** During the period of the warranty, this product is 100% waterproof and the structural integrity of the floor will not be diminished by exposure to water as herein described.

**Wear Resistance:** During the period of the warranty, this product's wear layer will not wear through to the decorative layer under normal use. Excessive wear due to improper maintenance or care is not a wear layer or product defect.



## WATERPROOF WOOD FLOORING INSTALLATION

### WHAT IS NOT COVERED BY THIS WARRANTY (Item list is not exhaustive)

- Improper Installation: Material that is not installed in accordance with the Installation Instructions is not a manufacturing related defect. Installer workmanship is not warranted.
- Labor cost to repair or replace material installed with visible defects/imperfections.
- Improper maintenance, resulting in gloss level loss.
- Damage resulting from use of strong detergents, chemicals, paints, dyes, improper mats, fertilizers, or other similar materials.
- Damage caused by rolling loads, including but not limited to chairs, appliances, or other objects are not covered by the warranty.
- Damage caused by moving appliances or heavy furniture without protecting the floor. (Always protect flooring by using protective covering when moving heavy objects.).
- Damage or scratches resulting from accidents, casualty events, abuse or improper usage (including damage from pet claws or teeth, urine, etc.). Accidents, abuse, and improper usage are defined as, but are not limited to damage caused by: casters on furniture, rotating beater bars on vacuum cleaners, burns, cuts, impact from heavy and sharp objects –with the Prescott exception, narrow or spike heels, cleats, etc., as well as, damage resulting from unprotected furniture legs. Chairs, sofas, or furniture with castors must be fitted with soft rubber wheels and have an adequate protective mat or protective castor cups to prevent rolling load damage.
- Damage caused by leaks from appliances or plumbing.
- Construction damage after installation.
- Installation-related errors or damage including improper conditioning of jobsite and flooring materials, when necessary, and/or poor subfloor performance or failure.
- Fading, discoloration, or other damage due to excessive temperatures or sunlight. Radiant heat must not exceed 85°F (29°C) and be approved by the manufacturer for the use of their product with resilient vinyl flooring applications.
- Problems or damage due to excessive moisture or hydrostatic pressure from the sub-floor.
- Discoloration caused by use of vinyl, latex, or rubber-backed floor mats. Note: some synthetic backed carpets contain latex in the manufacturing process that may discolor vinyl. Always use mats marked as "non-staining".
- Discoloration caused by rubber pads, rubber wheels, rubber tires, rubber rollers, automotive tires, etc.
- Flooring installed on stair is excluded from warranty coverage.
- Installation of residential product in a commercial environment.

If the product fails to perform as stated in the warranty, **Lifeproof** reserves the right to have the product inspected by a certified inspector. Should product be determined to be defective, **Lifeproof** reserves the right to either repair or replace the defective area with the same color, design, and grade product, if available. If product is unavailable or discontinued, **Lifeproof** reserves the right to select and supply similar material.

- If repairs or replacement of a section is deemed necessary, all items must be cleared from the affected area subsequent to the original installation. The cost associated with the removal of those items will not be credited or reimbursed.
- Product costs will be covered for the length of the warranty.
- Labor costs will not be covered.
- Warranty coverage for the replacement floor is limited to the remaining portion of the original warranty.
- Any additional claims for loss of profit or incidental losses due to defective product will not be considered. Some examples of incidental damages are: replacement of subfloors or underlayment, trim moldings, disconnecting /reconnecting appliances, moving of furniture or any other losses deemed incidental by **Lifeproof**.

Failure to follow these procedures may result in voiding some or all of the warranty. This limited warranty is non-transferable and extends only to the original end user. **Please note: Some jurisdictions do not allow exclusion or limitation of incidental or consequential damages or limitations on how long an implied warranty lasts, so the above limitation and exclusion may not apply to you.**

This warranty gives you specific right and you may also have other right, which vary from state to state.