

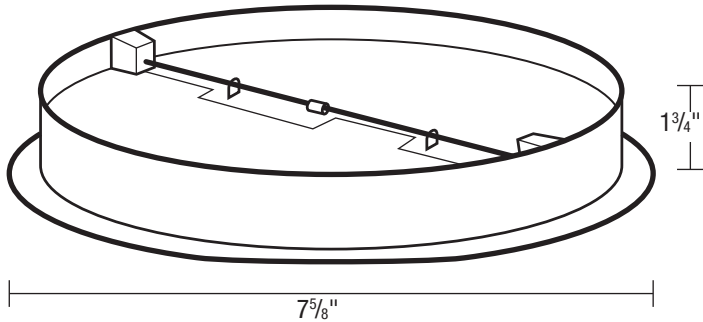

SPECIFICATIONS
ARD7R
 ADAPTER

Round Ducting Adapter

- **Construction**
Aluminum with mounting flange
- **Damper**
Painted, aluminum ring with butterfly type damper blades.
- **Uses**
For use with Air King AR, AV, DS, QZ and ESQZ series range hoods.
- **Shipping Information**
 Product Weight: 0.4 lbs.
 Dimensions: 7"D x 1 3/4"H x 7 5/8"L
 Shipping Weight: 0.5 lbs.
 UPC: 0-8316232201-2



PROJECT							ARCHITECT			
LOCATION							ENGINEER			
CONTRACTOR							SUBMITTED BY			DATE
FAN NUMBER	MODEL NUMBER	CFM	IN W.C.	RPM	WATTS	AMPS	SONES	QTY	OPTIONAL EQUIPMENT & REMARKS	

Air King: 820 Lincoln Avenue
 West Chester, Pennsylvania 19380-4466
 Tel: (610) 692-7400 • 877-304-3785
 Fax: (610) 696-8048