

UV AIR PURIFIER **UV**



MANUAL

TPP220H

thera|pure®

UV AIR PURIFIER **UV**

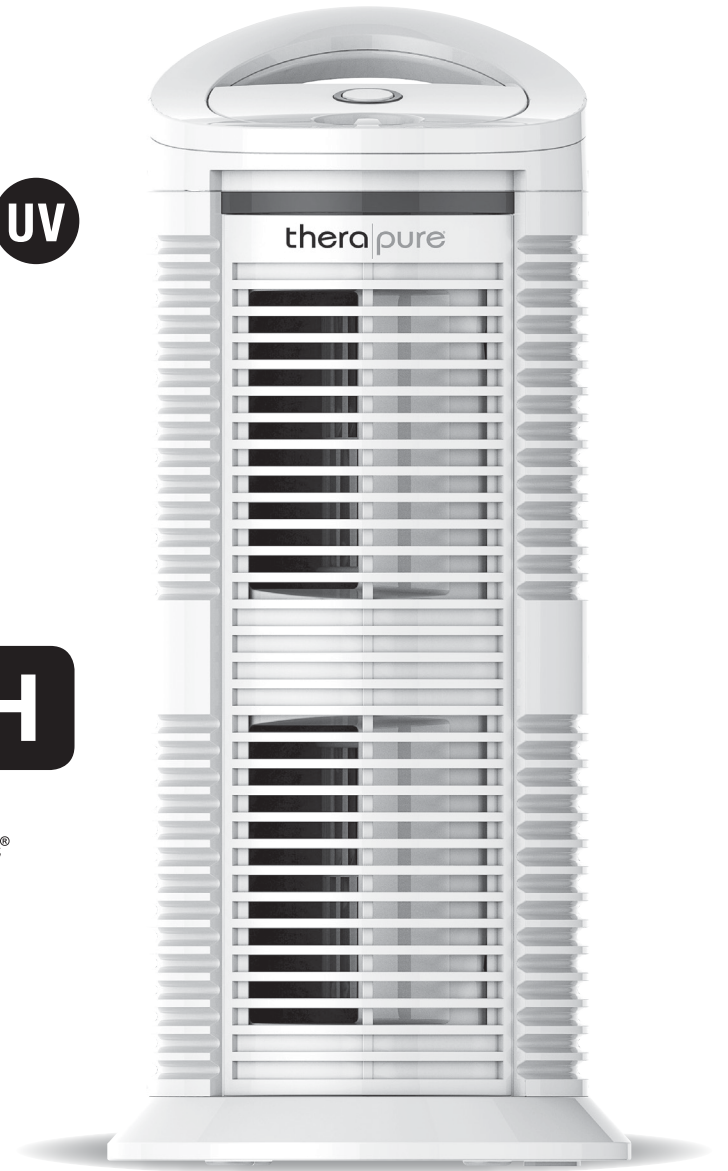

MANUAL

TPP220H

thera|pure®

TPP220H

thera|pure®

Thank you for purchasing the Therapure® 220H air purifier. With UV light and cleanable HEPA-Type filtration to clean the air, the Therapure® 220H air purifier will greatly improve the quality of the air in your home, office or other environments. We want you to be fully satisfied with your Therapure® 220H. That's why your Therapure® 220H comes with a one-year limited warranty.

Once you've experienced the purity of Therapure® 220H air, visit us at our website to find out more ways to improve the quality of your air and your life with our premium products and upgrades.

Please be sure to read the following instructions carefully to ensure optimal performance and safety.

envionproducts.com

Therapure® by BONECO North America Corp.
P.O. Box 9159
Van Nuys, CA 91409-8291
800.875.8577

by **ENVION**®

TABLE OF CONTENTS

SAFETY INSTRUCTIONS	2
IMPORTANT WARNINGS	3
UV Lamp Notice	3
Mercury Notice	3
UV Lamp Disposal Notice	3
UV Lamp Breakage	3
PRODUCT BENEFITS	4
MAIN PARTS	5
OPERATING THE THERAPURE® 220H AIR PURIFIER	6
Air Purifier Specifications	6
Getting Ready	7
Controls/Settings	8
CLEANING & MAINTENANCE	9
Cleaning the Permanent Filter	9
Maintenance UV Lamp	10
Cleaning External Surfaces	10
Replacing the UV Lamp	11
TROUBLE-SHOOTING	12
ONE-YEAR LIMITED WARRANTY	13
ARBITRATION AGREEMENT	14

SAFETY INSTRUCTIONS

READ AND SAVE THESE INSTRUCTIONS

WARNING: RISK OF ELECTRICAL SHOCK

Safety precautions should always be used when operating this or any electrical appliance. Decrease the risk of electrocution, electric shock, injury or fire by reading and following all the warnings below.

Use only as described in this Therapure® 220H manual. To reduce the risk of electric shock, do not attempt to service the product in any way other than in the manner described in the “**Cleaning & Maintenance**” section of this manual.

READ ALL INSTRUCTIONS BEFORE OPERATING THE AIR PURIFIER.

- » This product operates at 120V AC, 60Hz only.
- » Do not run cord under carpeting. Do not cover cord with throw rugs, runners, or similar coverings. Arrange cord away from traffic area and where it will not be tripped over.
- » Do not operate the product in any greasy environment, such as in the kitchen. This product is not intended to filter oil or grease from the air.
- » Do not use the Therapure® 220H air purifier in bathrooms or other humid environments. Do not use near fireplaces or in areas where flammable or combustible vapors or products may exist.
- » Always unplug the power cord from the electrical outlet when the purifier is not in use, before cleaning, inserting or removing parts or before moving to another location.
- » Never run the air purifier unless it is fully assembled.
- » This appliance has a polarized plug (one blade is wider than the other). To reduce the risk of electric shock, this plug is intended to fit in a polarized outlet only one way. If the plug does not fit fully in the outlet, reverse the plug. If it still does not fit, contact a qualified electrician. Do not attempt to defeat this safety feature.
- » Always turn off all controls before unplugging the Therapure® 220H air purifier from the outlet.
- » Attempting to service the Therapure® 220H air purifier in any way that is not described in this owner's manual will cause the warranty to be voided and could cause serious personal injury to the user and/or result in considerable damage to the unit.
- » Do not place the cord near a heated surface.
- » Do not operate this product with a damaged cord or plug. Discard the product or return to an authorized service facility for examination and/or repair.
- » Never use the power cord to pick up, carry, drag, pull, or lift the Therapure® 220H air purifier. Do not pull the cord against or around sharp corners and edges. This could result in injury to the user or damage to the cord.
- » Always remove the plug from its power outlet by holding onto the plug itself and pulling gently.
- » Never pull on the cord itself to unplug it from its power outlet.
- » Use care when operating the Therapure® 220H air purifier by keeping all foreign objects, fingers, body parts, hair, loose clothing and jewelry away from openings.
- » Never touch the Therapure® 220H air purifier or its plug when your hands are wet.
- » The Therapure® 220H air purifier is an electrical appliance. Adult supervision is required when operating the Therapure® 220H in the presence of children.
- » To reduce the risk of fire or electric shock, do not use this air purifier with any solid-state speed

IMPORTANT WARNINGS

UV Lamp Notice

UV Light is harmful to bare skin and eyes and can cause temporary or cleanable loss of vision. Never look directly at the UV lamp while it is illuminated; doing so could cause loss of vision! Only view illumination through the window at the front of the unit. To prevent exposure to ultraviolet light, disconnect the power to the unit before servicing any part of the Therapure® 220H air purifier.

UV Lamp Disposal

If the UV lamp breaks, turn off the unit. Do not operate the unit with a broken lamp. Do not use a vacuum to clean up breakage. Sweep debris into a plastic bag and dispose of properly. Contact your local waste management authority for instructions regarding recycling and the proper disposal of old lamp(s). To order a replacement lamp, call 1.800.875.8577 or go to envionproducts.com.

Mercury Notice

Because the Therapure® 220H contains a light bulb and light bulbs contain mercury, Envion is required to provide the following warning:

! WARNING: This product can expose you to Mercury, a chemical which is known to the state of California to cause birth defects or other reproductive harm. For more information, visit www.P65Warnings.ca.gov.

Do not place your used lamp(s) in the trash. Disposal of any item containing mercury must be in accordance with any hazardous waste disposal or recycling laws and regulations of your state.

TPP220H

thera|pure®

PRODUCT BENEFITS

- » Effectively reduces smoke, pollen, dust, VOCs, animal dander, dust mites, mold and bacteria.
- » 3 speed fan setting—lets you select the desired cleaning level.

TPP220H

thera|pure®

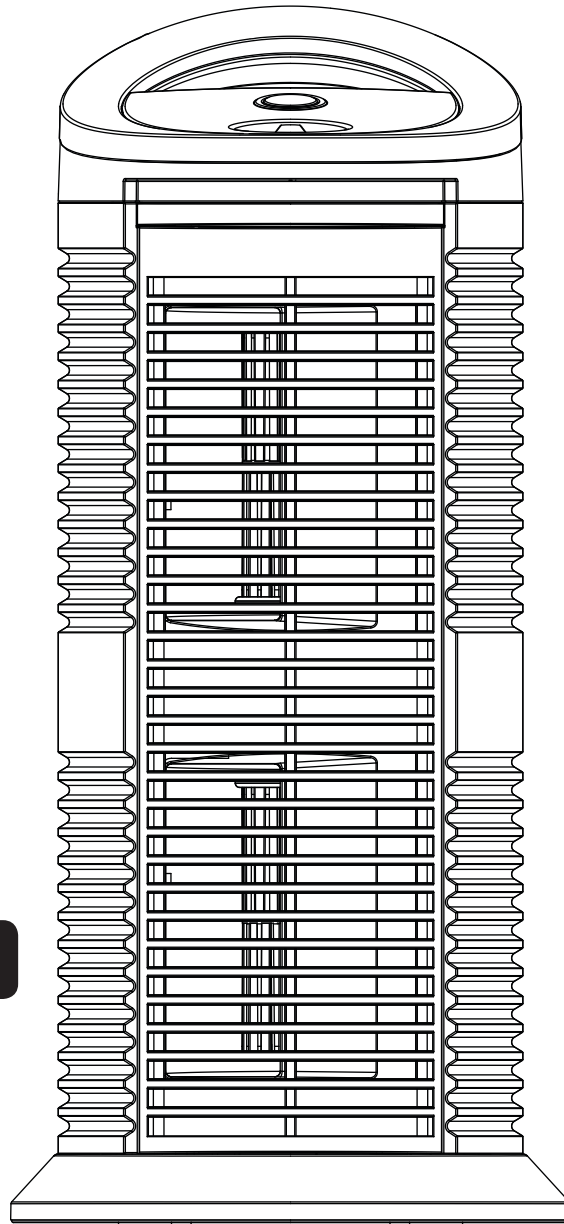

MAIN PARTS

1. Locking Latch
2. Air Inlet Grill
3. Permanent HEPA-Type filter: the permanent filter removes small visible and non-visible particles.
4. UV Lamp Cover
5. Control Panel
6. Control Dial: 3 fan speed settings: (low, medium and high).
7. UV Indicator Light
8. UV/VOC Button
9. Air Outlet Grill
10. Base of Unit
11. UV Lamp

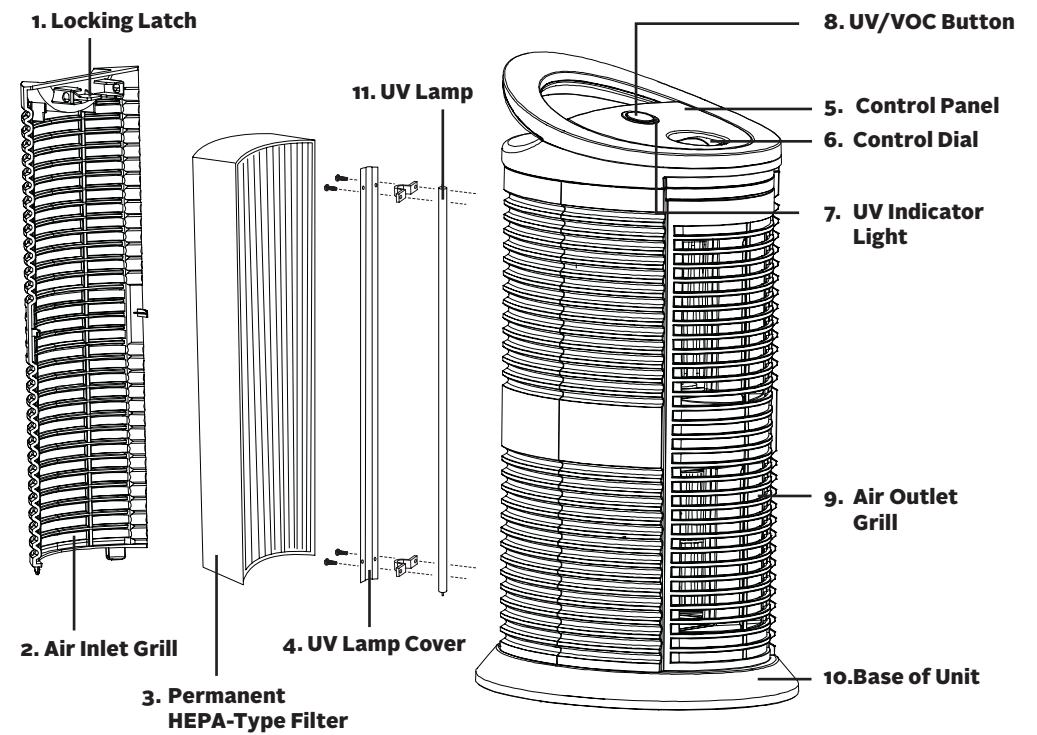

OPERATING THE THERAPURE® TPP220H

Before using the Therapure® 220H air purifier, please read the following important information.

Electrical Ratings:

- 120V Setting: 120Vac, 60 Hz
- Power consumption: 35 watts (0.5 ampere) at high fan speed,
- 3 watt UV light lamp
- Net weight: 5.2 lbs.
- Dimension (LxWxH): 9.6" x 7.9" x 17.25"

Replacement Parts:

Lamp – TPP2200

Filter – TPP220F

Locate a level surface on which to place the Therapure® 220H air purifier near a 120V outlet (follow warnings in the **"SAFETY INSTRUCTIONS"** and **"IMPORTANT WARNINGS"** sections of this manual). Position your Therapure® 220H at least one foot (12 inches) from the wall. Plug in the unit.

TPP220H

therapure®

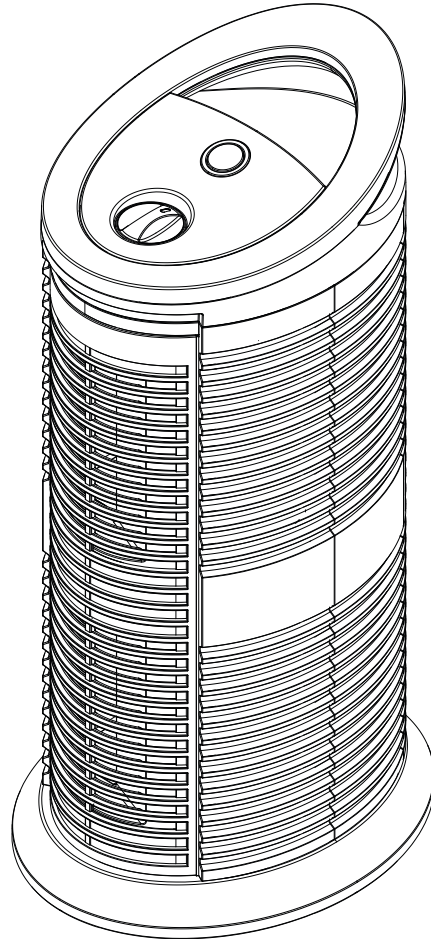

OPERATING THE THERAPURE® TPP220H

Before using the Therapure® 220H air purifier, please read the following important information.

Safety

1. Do not place near fans.
2. Keep both sides of the unit at least 1 foot away from a wall.
3. Do not place the unit near curtains.
4. Placing the unit close to the source of air pollution is an effective way to improve indoor air quality.

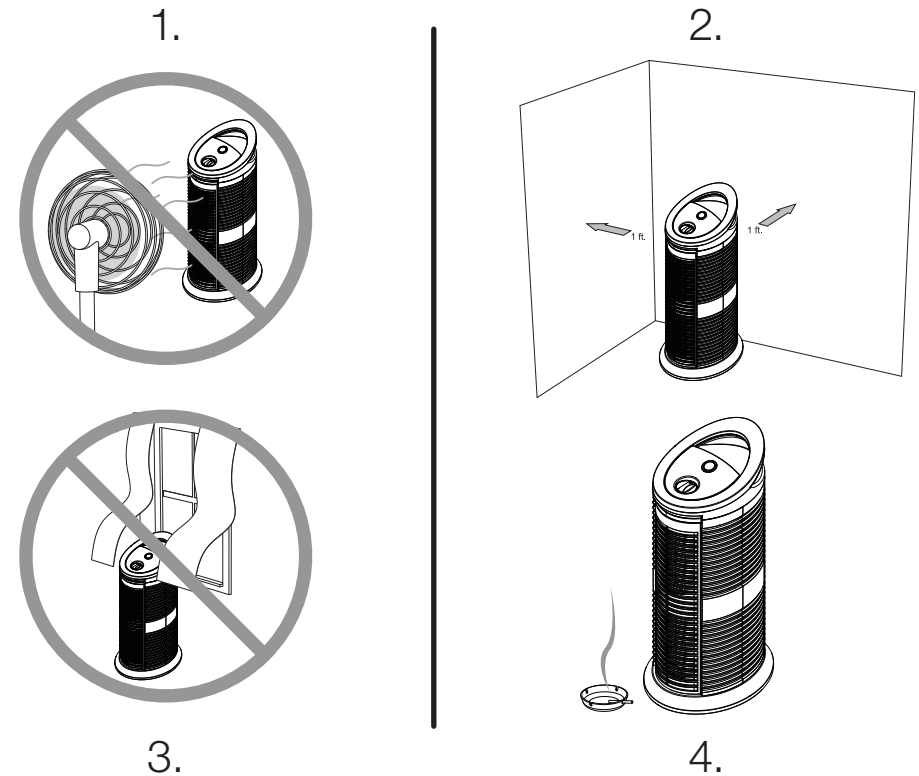

Note:

DO NOT run the Therapure® 220H with a broken filter. Replace the filter if the filter has a tear or a hole in it.

If the filter is damaged or needs replacement, please visit the Therapure® website at envionproducts.com to order for a replacement filter. Or call **1.800.875.8577**.

OPERATING THE THERAPURE® TPP220H

CONTROLS/SETTINGS:

Power Control – To operate the Therapure® air purifier, turn the Control Dial clockwise to turn on.

Speed Control – The Therapure® has three different speeds of cleaning, LOW, MED and HI. Turn the knob ONCE for LOW, TWICE for MED and THIRD for HI.

UV Control – Press the UV/VOC control button “UV/VOC” to turn on the UV lamp. Press it again to turn off the UV and VOC. A blue UV indicator light will light up around the button when UV/VOC is turned on.

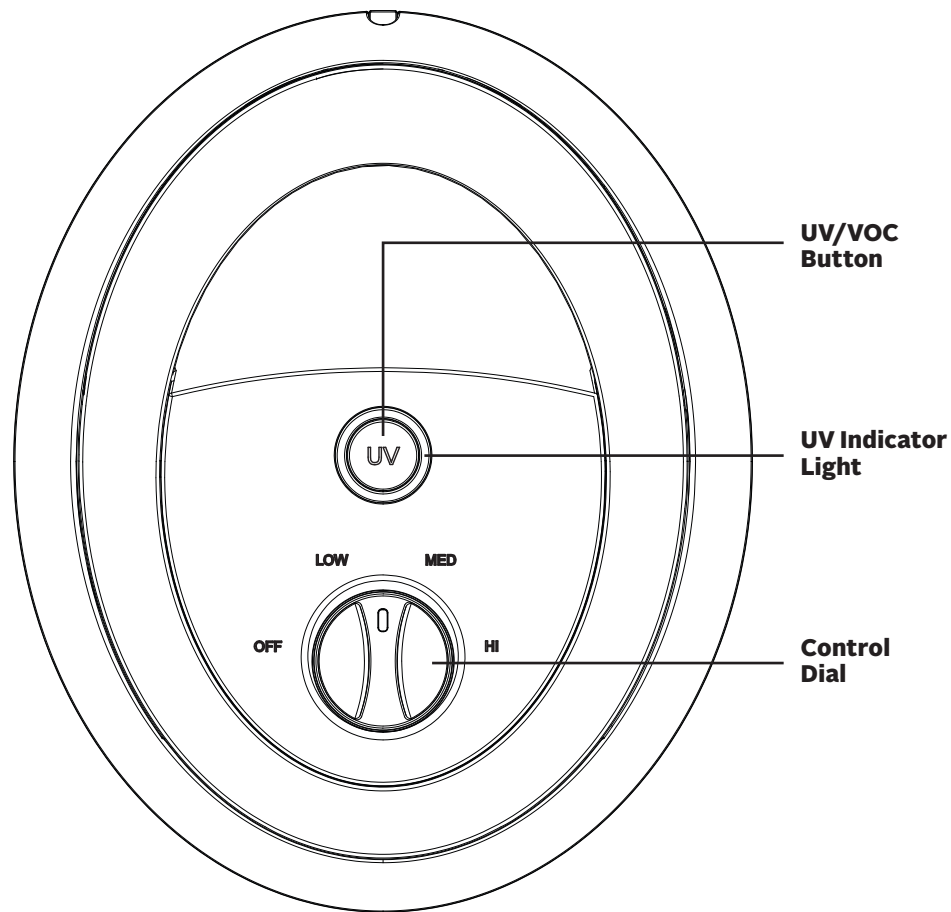

CLEANING & MAINTENANCE

Keep the Therapure® 220H functioning properly by cleaning the permanent HEPA-Type filter every four weeks. More frequent cleaning will be necessary if the unit is located in an area with a high level of airborne contaminants (excessive amounts of smoke, pet dander, etc.).

Exposing the Therapure® 220H to candle/oil/fireplace soot and smoke is not recommended and will require more frequent cleaning.

Note: Always make sure the Therapure® 220H is turned off and unplugged before cleaning.

- » **Vacuuming will restore performance of the permanent HEPA-Type filter. However, the filter may appear stained. This is normal and does not affect performance in any way.**
- » **Do not use water or any household cleaners or detergents to clean the permanent HEPA-Type filter.**
- » **The inlet grill may be cleaned (after unit is turned off and unplugged) with a vacuum or a slightly damp cloth.**

Cleaning the permanent HEPA-Type filter (steps 1-4 shown).

1. Release the inlet grill by pressing on the locking latch (see diagram of Main Parts).
2. Remove the inlet grill from the unit as shown below.
3. Grasp the left and right frames of the permanent HEPA-Type filter through the indentations on the sides of the filter enclosure and remove the filter.
4. To clean the permanent HEPA-Type filter, use the brush or crevice attachment with a vacuum cleaner. Run the attachment along the inlet and outlet side of the filter, cleaning between the crevices as much as possible. **Do not use water or any household cleaners or detergents to clean the permanent HEPA-Type filter.**
5. Once the permanent HEPA-Type filter has been cleaned and checked for any possible damage, replace the filter back in the reverse direction described here.

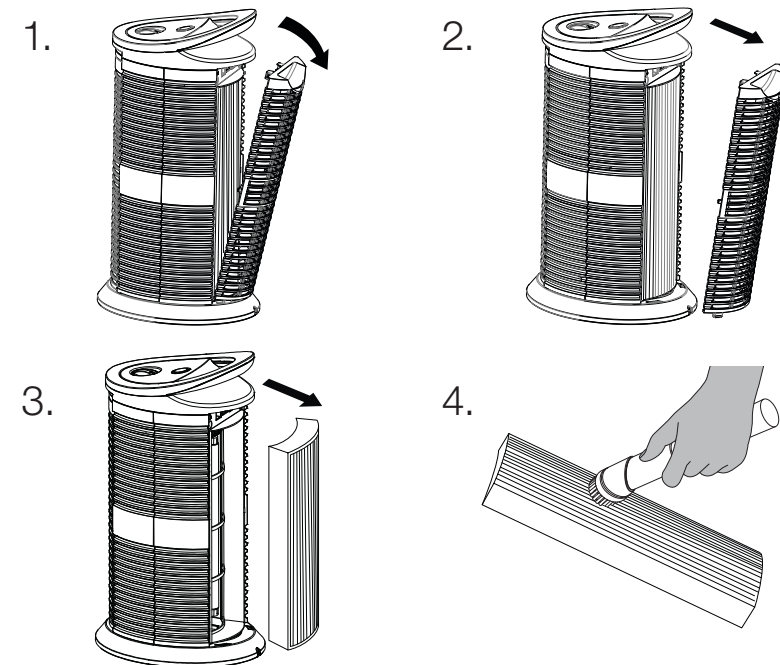

CLEANING & MAINTENANCE

Cleaning External Surfaces

1. Turn off and unplug unit.
2. Use a washcloth slightly dampened with a little water and dishwashing soap to wipe the outer case surfaces.
3. Do not allow water to slip into the internal parts as this could damage your unit and result in electrical shock and injury to you.
4. Allow the unit to thoroughly dry before use.

UV Lamp

The lifetime of the UV lamp is up to 12 months of continuous, effective operation. After this time, the bulb may remain illuminated, but its effectiveness is greatly reduced. **For maximum effectiveness, please replace the UV bulb annually.**

If the lamp stops functioning or needs replacement, please visit our web site at envionproducts.com to order a replacement lamp. Or call 1.800.875.8577.

Caution:

- Do not touch the glass part of the lamp. Oil from fingertips will decrease the effectiveness of the lamp.
- Never operate the unit without a filter or with a damaged filter. UV lamp cover must be installed at all times. The UV light from the UV lamp will result in severe damage to eyes and could cause blindness.

UV Lamp Notice Warning:

UV Light is harmful to bare skin and eyes and can cause temporary or cleanable loss of vision. Never look directly at the UV lamp while it is illuminated-doing so could cause loss of vision!

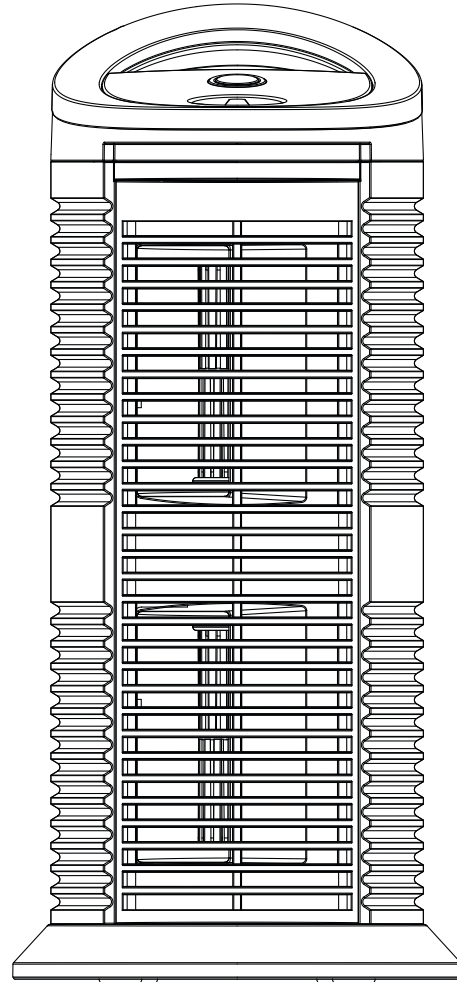

TPP220H

thera|pure®

CLEANING & MAINTENANCE

Before replacing the UV lamp, make sure the Therapure® 220H air purifier is turned off and unplugged. Let the lamp cool down for 5 minutes before replacing it.

Replacing the UV Lamp:

1. Release the inlet grill by pressing on the locking latch (see diagram of Main Parts).
2. Remove the two bolts used to fix the UV lamp cover and remove the cover out from the unit.
3. Unscrew the old UV lamp from the lamp base of the unit.
4. Install the new UV lamp into the lamp base of the unit.
5. Install the UV lamp cover with the two bolts on the unit.
6. Install the inlet grill on the unit.

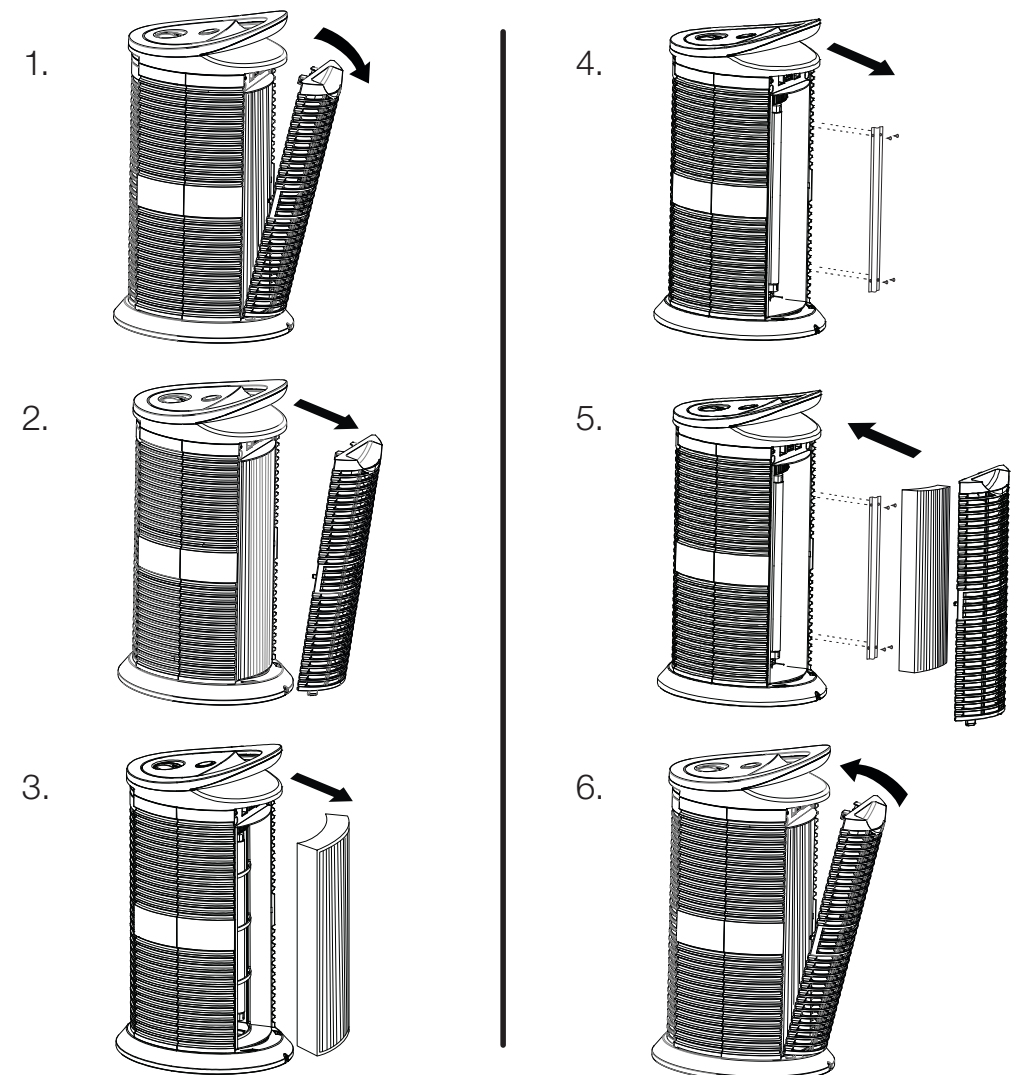

TROUBLESHOOTING

PROBLEM	REASON	SOLUTION
Unit will not operate	Power button has not been turned on.	Press the Power button.
	Unit is unpugged.	Check to ensure unit is plugged in.
	The inlet grill has not been installed & locked into place.	Check to make sure filter and inlet grill is properly installed & locked into place.
Reduced airflow or poor filtering	The inlet or outlet grill may be blocked.	Check to ensure nothing is blocking the air inlet & outlet.
	Cleanable filter may be clogged.	Check & clean the filter, if necessary.
No visible light in the UV light view window	UV button is not turned on	Check that the UV button is turned on
	UV lamp is broken	Replace the UV lamp

ONE-YEAR LIMITED WARRANTY

ONE YEAR LIMITED WARRANTY

Your Therapure® 220H air purifier is warranted to be free from defects in materials and workmanship for one year from the original purchase date. Should the product have a defect in materials or workmanship, we will repair or replace it without charge to you (a shipping and processing fee will apply). To obtain service under warranty, simply call our customer service center toll-free at **800.875.8577** | M-F 7-4 PST / 7-3 Sat.

This warranty does not cover damage caused by accident, misuse or any use other than as intended and described in this product manual, or damage resulting from failure to maintain and clean this product as specified in this product manual. This warranty applies only to the original purchaser of the Therapure® 220H air purifier.

ALL EXPRESS AND IMPLIED WARRANTIES FOR THIS PRODUCT, INCLUDING IMPLIED WARRANTIES OF MERCHANTABILITY AND FITNESS FOR A PARTICULAR PURPOSE, ARE LIMITED IN DURATION TO THE WARRANTY PERIOD, AND NO WARRANTIES, WHETHER EXPRESS OR IMPLIED, WILL APPLY AFTER THIS PERIOD.

Some states do not allow limitations on the duration of implied warranties, so the above limitation may not apply to you. While this warranty gives you specific legal rights, you may also have other rights which may vary from state to state.

Contact Info for Warranty Service:

Therapure® by BONECO North America Corp.
P.O. Box 9159 | Van Nuys, CA | 91409-8291
1.800.875.8577 | envionproducts.com

© 2019 BONECO North America Corp. All Rights Reserved. Patents Pending.

TPP220H

thera|pure®

by **ENVION**®

ARBITRATION AGREEMENT

PLEASE READ THIS AGREEMENT CAREFULLY. YOU ACCEPT THE TERMS OF THIS AGREEMENT BY RETAINING THE PRODUCT(S) SHIPPED IN CONNECTION WITH THIS AGREEMENT (THE "PRODUCTS") FOR MORE THAN THIRTY (30) DAYS AFTER RECEIPT. IF YOU DO NOT AGREE TO THE TERMS OF THIS AGREEMENT, YOU MAY RETURN THE PRODUCT TO COMPANY WITHIN THIRTY (30) DAYS OF RECEIPT FOR A FULL REFUND.

THIS ARBITRATION AGREEMENT ("AGREEMENT") CONTAINS A MANDATORY ARBITRATION PROVISION THAT AFFECTS YOUR LEGAL RIGHTS AND REMEDIES BY PROVIDING THAT DISPUTES BETWEEN YOU AND THE MANUFACTURER, DISTRIBUTOR AND/OR SELLER OF THIS PRODUCT (COLLECTIVELY, "COMPANY"), MUST BE RESOLVED THROUGH BINDING ARBITRATION AND NOT IN COURT. IT ALSO PROVIDES THAT ANY DISPUTE CANNOT BE RESOLVED IN A CLASS ACTION OR OTHER PROCEEDING WHERE YOU REPRESENT OTHER PERSONS OR OTHER PERSONS REPRESENT YOU, AND THAT NO CLASS OR REPRESENTATIVE ARBITRATIONS ARE PERMITTED. PLEASE CAREFULLY READ ALL TERMS IN THIS AGREEMENT.

1. RESOLUTION OF CLAIMS OR DISPUTES.

Any claim or dispute between you and Company (or any of Company's subsidiaries or affiliates) arising out of or relating in any way to the Product or this Agreement shall be resolved through final, binding arbitration. This arbitration obligation is reciprocally binding on both you and the Company and applies regardless of whether the claim or dispute involves a tort, fraud, misrepresentation, product liability, negligence, violation of a statute, or any other legal theory. Both you and Company specifically acknowledge and agree that you waive your right to bring a lawsuit based on such claims or disputes and to have such lawsuit resolved by a judge or jury.

2. LIMITATION OF LEGAL REMEDIES.

All arbitrations under this Agreement shall be conducted on an individual (and not a class-wide) basis, and an arbitrator shall have no authority to award class-wide relief. You acknowledge and agree that this Agreement specifically prohibits you and the Company from commencing arbitration proceedings as a representative of others or joining in any arbitration proceedings brought by any other person. The parties agree that no class or representative actions of any type are permitted.

3. ARBITRATION PROCEDURES.

- a. Before instituting an arbitration, if you have any dispute, we strongly encourage you to contact the Company to try to resolve the matter by calling 800-875-8577, although you are not required to do so.
- b. The arbitration of any claim or dispute under this Agreement shall be conducted in accordance with the expedited procedures set forth in the JAMS Comprehensive Arbitration Rules and Procedures as those Rules exist on the date you receive the Product, including Rules 16.1 and 16.2 of those Rules. These rules and procedures are available by calling JAMS or by visiting its web site at www.jamsadr.com. The arbitration of any claim or dispute under this Agreement shall be conducted by an arbitrator who has at least five years of experience conducting arbitrations.
- c. The arbitration of any claim or dispute under this Agreement shall be conducted in the State of California or the location in which you received this Agreement. For claims of \$10,000 or less, you may choose whether the arbitration proceeds in person, by telephone, or based only on submissions.
- d. The Company shall pay costs for the arbitration of claims, including any JAMS Case Management Fee and all professional fees for the arbitrator's services. The Company shall pay the fees and costs of its own counsel, experts and witnesses and shall not be able to recoup them from you even if you do not prevail in the arbitration. Unless otherwise provided by law, you acknowledge and agree that you shall pay the fees and costs of your own counsel, experts and witnesses.

4. CHOICE OF LAW.

The arbitration provisions of this Agreement and any arbitration conducted pursuant to the terms of this Agreement shall be governed by the Federal Arbitration Act (9 U.S.C. Secs. 1-16). In this respect, the parties acknowledge that this Agreement involves a transaction conducted in interstate commerce. Otherwise, this Agreement and the rights of the parties hereunder shall be governed by and construed in accordance with the laws of the State of California, exclusive of conflict or choice of law rules.

5. SEVERABILITY.

If any provision of this Agreement is declared or found to be unlawful, unenforceable or void, such provision will be ineffective only to the extent that it is found unlawful, unenforceable or void, and the remainder of the provision and all other provisions shall remain fully enforceable.



TPP220H

thera|pure®

TPP220H

thera|pure®