

Parts List Drawing - DXCM602

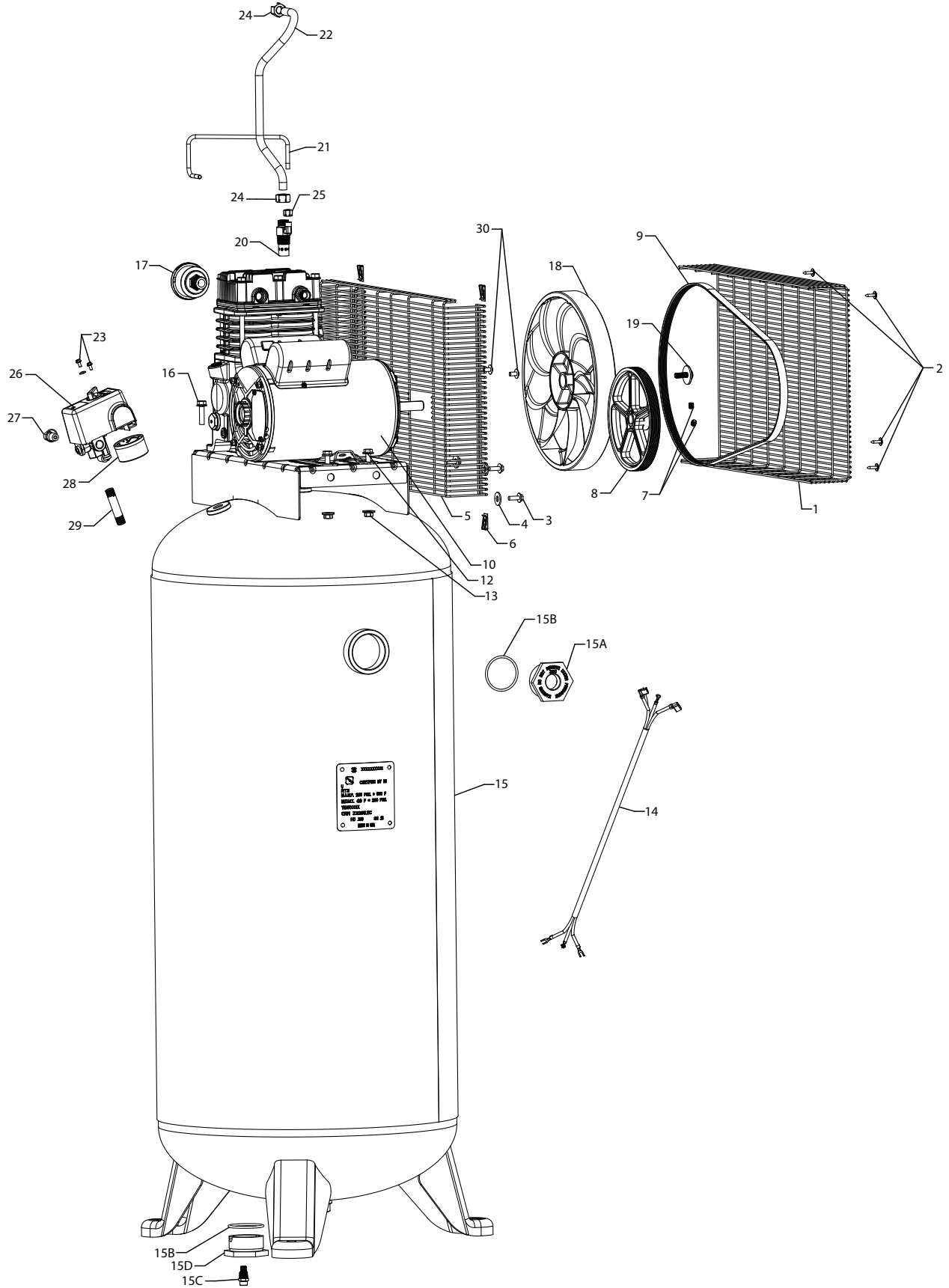

Parts List - DXCM602

ITEM	PART NO.	DESCRIPTION	QTY REQ'D
1	E110660	BELTGUARD (OUTER)	1
2	E110883	SCREW - #8-32 X .75, KIT OF 4 - TORQUE 8 - 15 IN-LBS	4
3	E106611	SCREW 1/4" - 20 X 3/4" HEX FLANGE HEAD - TORQUE 40-50 IN-LBS	3
4	E110549	WASHER 3/8" ID X 7/8" OD X .105 THK	3
5	E110587	BELTGUARD (INNER)	1
6	E110884	NUT SPEED "U" TYPE 8AB, KIT OF 4	4
7	E110558	SET SCREW 5/16"-18 X 3/8", KIT OF 2 - TORQUE 60-80 IN-LBS	2
8	E110537	KIT PULLEY 6.923" OD X 5/8" BORE INCLUDES ITEMS 7 & 11	1
9	E110538	BELT POLY-V 6 RIB-BELT TENSION ~160Hz	1
10	SEE INSERT	MOTOR	1
11	E110547	KEY 3/16" X 3/16" X 1-3/8" (NOT SHOWN)	1
12	E108112	SCREW 5/16" - 18 X 3/4", KIT OF 5 - TORQUE 20-25 FT-LBS	4
13	E108113	NUT 5/16" - 18 HEX FLANGE SERRATED, KIT OF 5	4
14	E105991	CORD MOTOR POWER	1
15	E113365	TANK ASSEMBLY PAINTED	1
15A	E106539	BUSHING 2" NPSM X 3/4" NPTF	1
15B	E105995	O-RING 2", KIT OF 2	2
15C	E109170	VALVE DRAIN 1/4" NPT	1
15D	E105994	BUSHING 2" NPSM X 1/4" NPTF	1
16	E110550	SCREW 5/16" - 18 x 1 1/4" HEX FLANGE HEAD - TORQUE 15 - 20 FT-LBS	4
17	E105207	FILTER AIR INTAKE 1/2" NPT	1
18	E110540	FLYWHEEL 12"	1
19	E110541	SCREW SEMS M8 X 1.25 X 25 MM - TORQUE 20 - 24 FT-LBS	1
20	E106027	VALVE CHECK 1/2" NPT X 1/2" OD TUBE	1
21	E106001	TUBE 1/4" PRESSURE RELIEF	1
22	E113329	TUBE 1/2" OUTLET INCLUDES ITEM 24 - TORQUE 100-200 IN-LBS	1
23	E106643	GROUND SCREW #8-32 X 3/8", KIT OF 2	2
24	E106641	NUT COMPRESSION 1/2" OD TUBE - TORQUE 100-200 IN-LBS	2
25	E105999	NUT COMPRESSION 1/4" OD TUBE - TORQUE 35-65 IN-LBS	1
26	E106003	SWITCH PRESSURE 145-175 PSI	1
27	E108520	VALVE SAFETY RELIEF 200 PSI	1
28	E106005	GAUGE 2" 300 PSI 1/4" - 18 NPT	1
29	E110559	NIPPLE 1/4" - 18 NPT X 2.50"	1
30	E108246	SCREW 1/4" - 20 X 1/2" PAN HEAD - TORQUE 45-60 IN-LBS	2
31	E110586	PADS VIBRATION ISOLATOR (NOT SHOWN), KIT OF 4	3
32	E106631	WARNING LABEL (NOT SHOWN)	1
33	E106630	WARNING LABEL HOT SURFACE (NOT SHOWN)	1

Pump Parts Drawing - DXCM602

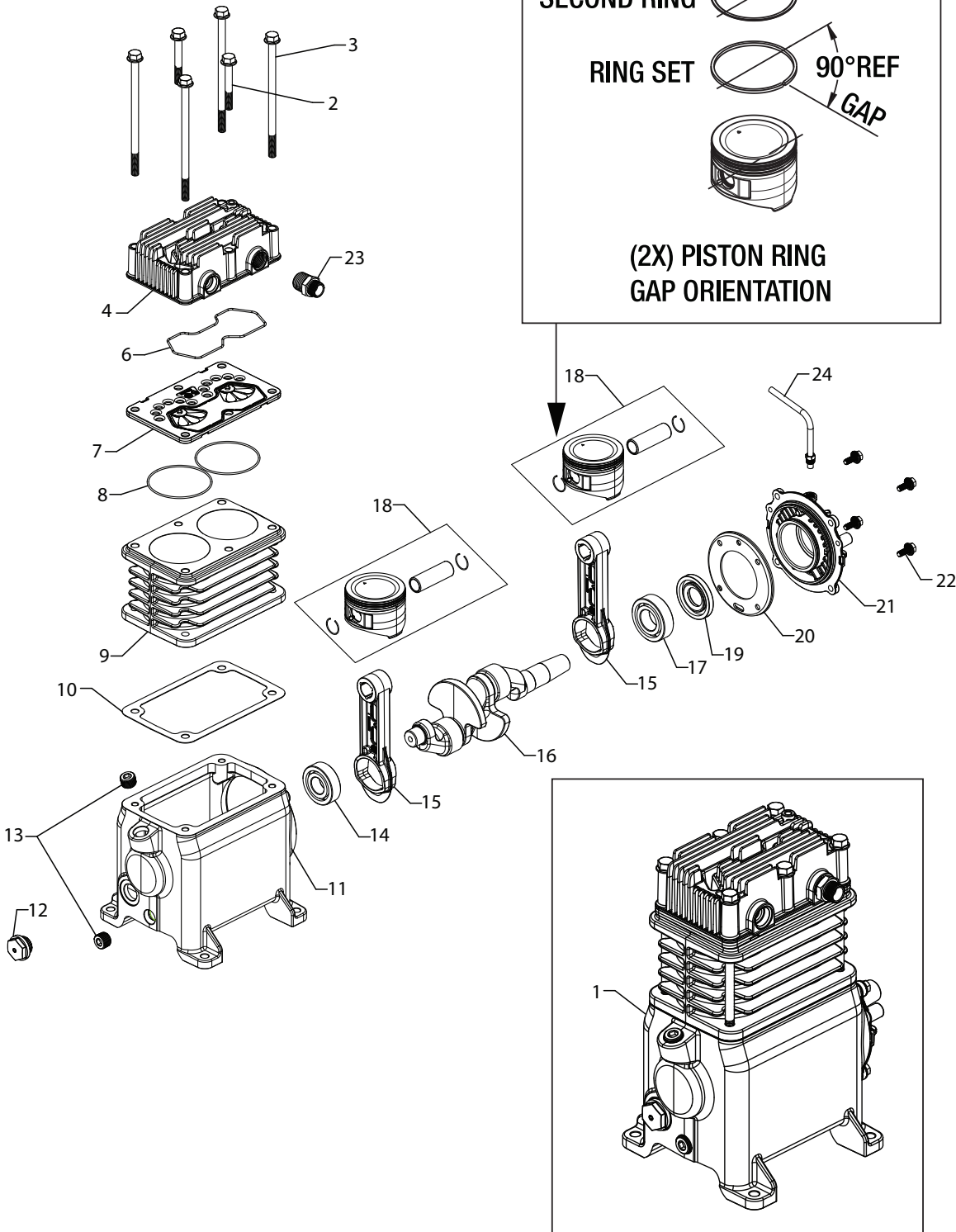

Pump Parts List - DXCM602

ITEM	PART NO.	DESCRIPTION	QTY REQ'D
1	E113242	PUMP I11 WITH THREADED EXHAUST PORT	1
2	E110560	SCREW M8 X 1.25 X 60 MM HEX FLANGE HEAD, KIT OF 2 - TORQUE 15-20 FT-LBS	2
3	E110561	SCREW M8 X 1.25 X 150 MM HEX FLANGE HEAD, KIT OF 4 - TORQUE 15-20 FT-LBS	4
4	E113241	HEAD PUMP WITH THREADED EXHAUST PORT	1
5	E110580	GASKET KIT INCLUDES ITEMS 6,8,10,12,19 & 20	1
6	E110563	O-RING FORMED	1
7	E110564	ASSEMBLY VALVE PLATE	1
8	E110565	O-RING, KIT OF 2	2
9	E110566	CYLINDER	1
10	E110567	GASKET	1
11	E110568	CRANKCASE	1
12	E110542	OIL SIGHTGLASS - TORQUE 40-50 IN-LBS	1
13	E110543	PLUG 3/8" NPT, KIT OF 2 - TORQUE 60-72 IN-LBS	2
14	E110569	BEARING 20 MM (6204)	1
15	E110571	CONNECTING ROD, KIT OF 1	2
16	E110570	CRANKSHAFT	1
17	E110574	BEARING 25 MM (6205)	1
18	E110575	PISTON ASSEMBLY, KIT OF 2	2
19	E110576	SEAL OIL	1
20	E110577	BAFFLE	1
21	E110578	COVER BEARING	1
22	E110579	SCREW M6 X 1 X 16 MM HEX FLANGE HEAD SERRATED, KIT OF 4 - TORQUE 140-160 IN-LBS	4
23	E113222	CONNECTOR FITTING 1/2"NPT X 1/2" TUBE - TORQUE 15-25 FT-LBS	1
24	E114247	VENT TUBE ASSEMBLY - TORQUE 20-25 IN-LBS	1

Nomenclature des pièces - DXCM602

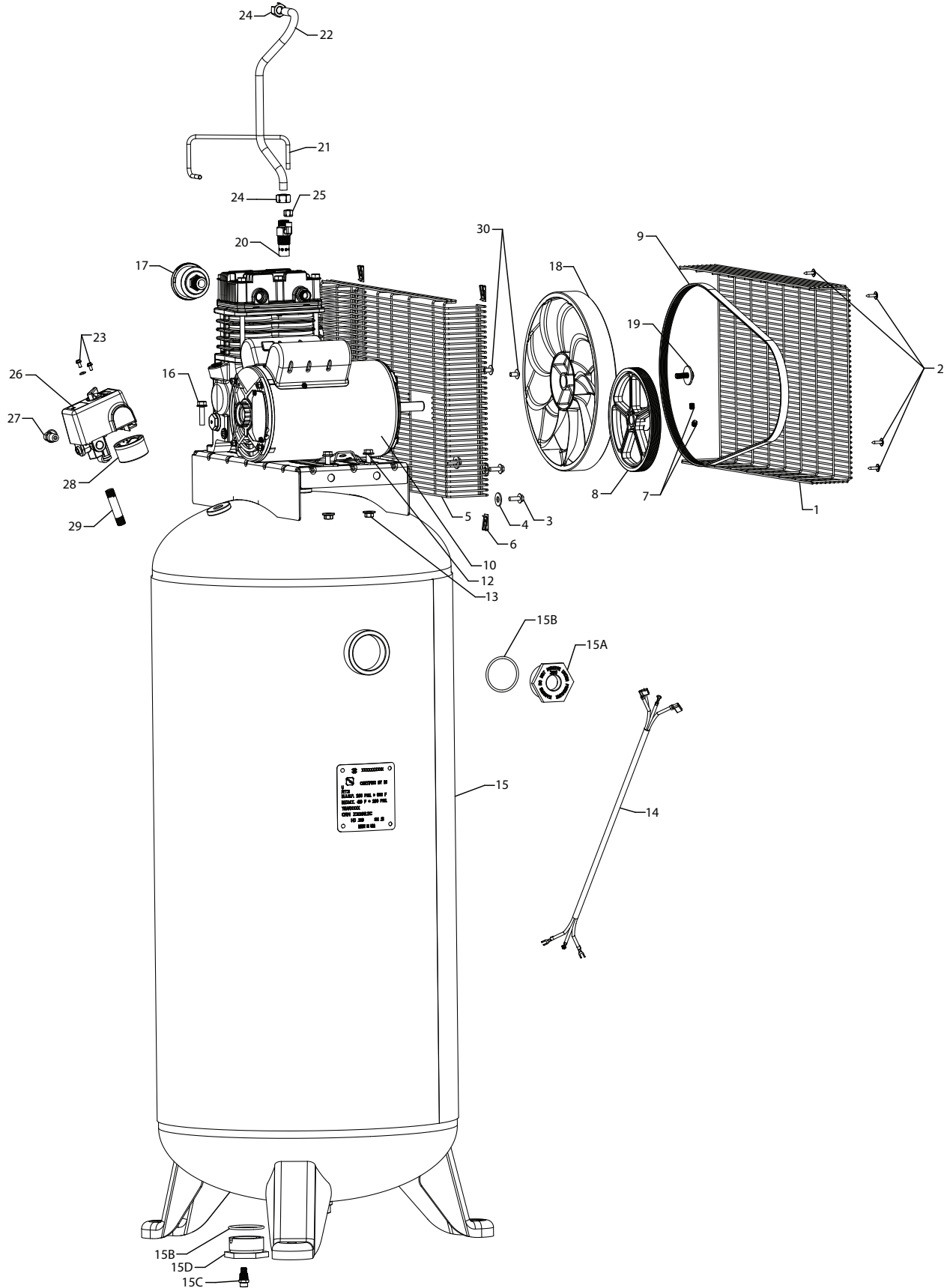

Nomenclature des pièces - DXCM602

NO. RÉF.	NO. PIÈCE	DESCRIPTION	QTÉ
1	E110660	GARDE-COURROIE (EXTÉRIEUR)	1
2	E110883	VIS AUTOTARODEUSE N° 8-32 X 0,75, JEU DE 4, COUPLE 8-15 PO-LB (1-1.7 Nm)	4
3	E106611	VIS TÊTE HEX À ÉPAULEMENT ¼ po - 18 x 3/4 po - COUPLE 40-50 PO-LB (4.5-5.6 Nm)	3
4	E110549	RONDELLE 3/8 po DIAM. INT. X 7/8 po DIAM. EXT. X .105 THK	3
5	E110587	GARDE-COURROIE (INTÉRIEUR)	1
6	E106733	ÉCROU DE SÉCURITÉ TYPE "U" - M5 X .8 - EXTRUDÉ	4
7	E110558	JEU DE VIS DE RÉGLAGE 5/16 po -18 X 3/8 po - COUPLE 120-130 PO-LB (13.6-14.7 Nm)	2
8	E110537	JEU DE POULIE 6.923 DIAM. EXT. X 5/8 po ALÉSAGE - INCLUT PCES # 7 et 11	1
9	E110538	COURROIE POLY EN "V" – 6 RAINURES / TENSION DE COURROIE ~160Hz	1
10	VOIR L'INSERTION	MOTEUR	1
11	E110547	CLÉ 3/16 po X 3/16 po X 1-3/8 po (NON ILLUSTRÉE)	1
12	E108112	VIS 5/16 po - 18 X ¾ po - COUPLE 20-25 PI-LB (27-32 Nm)	4
13	E108113	ÉCROU 5/16 po - 18 HEX ÉPAULEMENT DENTELÉ, TROUSSE DE 5	4
14	E105991	MOTEUR, CORDON ÉLECTRIQUE	1
15	E113365	ASSEMBLAGE DE RÉSERVOIR, PEINT	1
15A	E106539	ANNEAU 2 po NPSM X ¾ po NPTF	1
15B	E105995	ANNEAU "O" 2 po, TROUSSE DE 2	2
15C	E109170	SOUPAPE DE VIDANGE ¼ po NPT	1
15D	E105994	ANNEAU 2 po NPSM X ¼ po NPTF	1
16	E110550	VIS TÊTE HEX À ÉPAULEMENT 5/16 po - 18 x 1 ¼ po - COUPLE 15-20 PI-LB (20-27 Nm)	4
17	E105207	FILTRE D'ENTRÉE D'AIR 1/2 po NPT	1
18	E110540	VOLANT MOTEUR 12 po	1
19	E110541	VIS SEMS (à rondelle) M8 X 1.25 X 25 MM - COUPLE 20-24 PI-LB (27-32 Nm)	1
20	E106027	CLAPET ANTI-RETOUR ½ po NPT X ½ po TUBE DIAM. EXT.	1
21	E106001	CONDUITE DE DÉCHARGE DE PRESSION - ¼ po	1
22	E113329	JEU DE TUBES DE SORTIE – ½ po - INCLUT PCE. 24- COUPLE 100-200 PO-LB (11.3-22.6 Nm)	1
23	E106643	VIS DE MISE À LA TERRE #8-32 x 3/8 po, TROUSSE DE 2	2
24	E106641	ÉCROU DE COMPRESSION ½ po DIAM. EXT. POUR TUBE - COUPLE 100-200 PO-LB (11.3-22.6 Nm)	2
25	E105999	ÉCROU DE COMPRESSION ¼ po DIAM. EXT. POUR TUBE - COUPLE 35-65 PO-LB (4-7 Nm)	1
26	E106003	MANOSTAT 1000-1207 kPa / 145-175 PSI	1
27	E108520	SOUPAPE DE DÉCHARGE DE SÉCURITÉ 200 PSI	1
28	E106005	MANOMÈTRE 2 po - 300 PSI ¼ po - 18 NPT	1
29	E110559	RACCORD FILETÉ ¼ po NPT-18 X 2.50 po	1
30	E108246	VIS À PANS CREUX ¼ po -20 X ½ po – COUPLE 45-60 PO-LB (5-6.8 Nm)	2
31	E110586	TAMPONS ANTI-VIBRATION (NON ILLUSTRÉS), TROUSSE DE 4	3
32	E106631	ÉTIQUETTE D'AVERTISSEMENT (NON ILLUSTRÉE)	1
33	E106630	ÉTIQUETTE D'AVERTISSEMENT - SURFACE CHAUDE (NON ILLUSTRÉE)	1

Dessin de pièces - Pompe - DXCM602

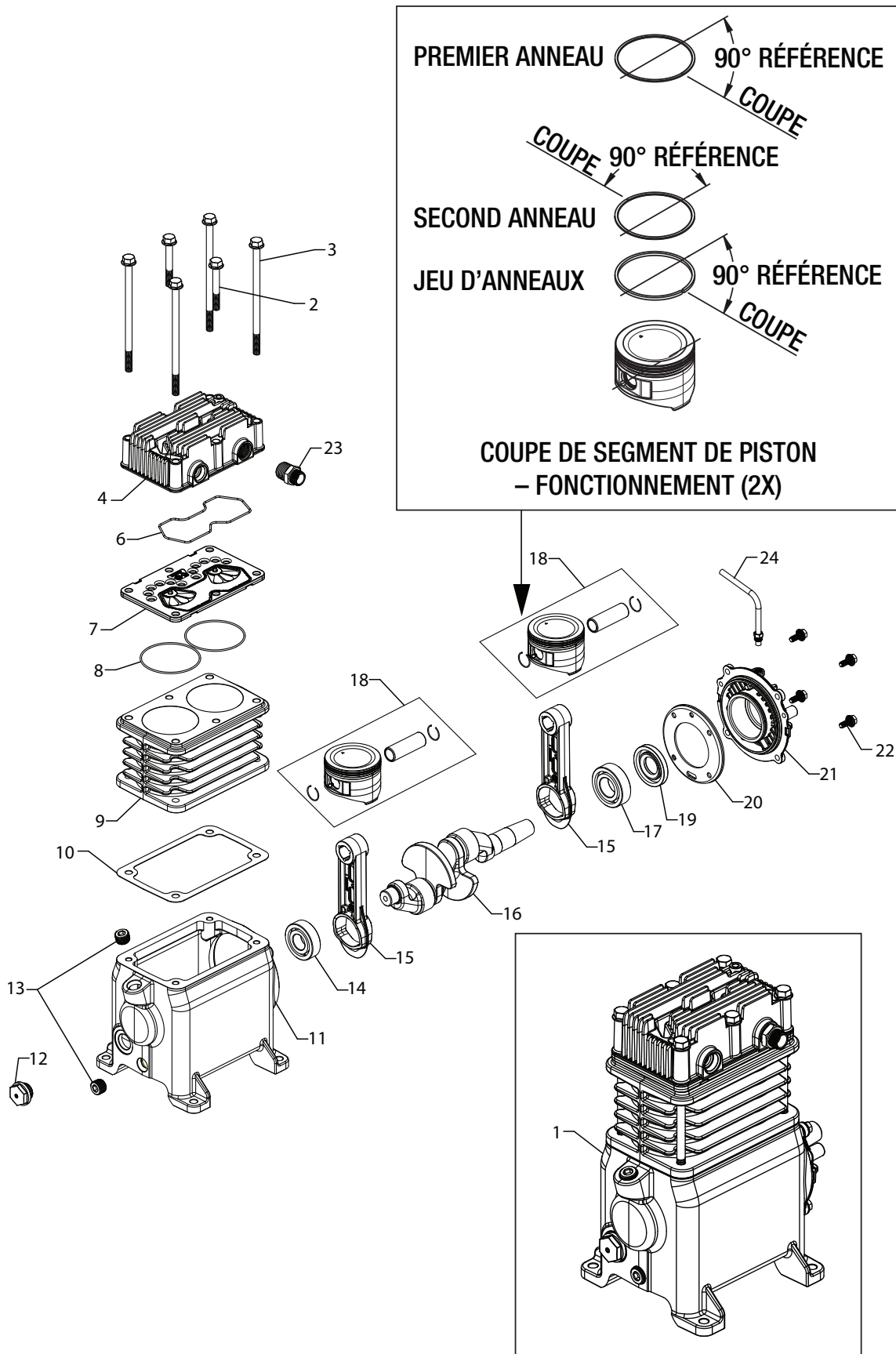

Liste de pièces - Pompe - DXCM602

NO. RÉF.	NO. PIÈCE	DESCRIPTION	QTÉ
1	E113242	POMPE I11 DOTÉE D'UN ORIFICE D'ÉCHAPPEMENT FILETÉ	1
2	E110560	VIS M8 X 1.25 X 60 MM TÊTE HEX ÉPAULEMENT, TROUSSE DE 2 - COUPLE 15-20 PI-LB (20-27 Nm)	2
3	E110561	VIS M8 X 1.25 X 150 MM TÊTE HEX ÉPAULEMENT, TROUSSE DE 4 - COUPLE 15-20 PI-LB (20-27 Nm)	4
4	E113241	POMPE DE PRESSION DOTÉE D'UN ORIFICE D'ÉCHAPPEMENT FILETÉ	1
5	E110580	TROUSSE DE JOINTS COMPRENANT LES PIÈCES 6,8,10,12,19 ET 20	1
6	E110563	BAGUE EN "O", FORMÉE	1
7	E110564	ASSEMBLAGE, PLAQUE PORTE-SOUPAPE	1
8	E110565	ANNEAU "O", TROUSSE DE 2	2
9	E110566	CYLINDRE	1
10	E110567	JOINT	1
11	E110568	CARTER	1
12	E110542	VOYANT, HUILE - COUPLE 40-50 PO-LB (4.5-5.6 Nm)	1
13	E110543	BOUCHON 3/8" NPT, TROUSSE DE 2 - COUPLE 60-72 PO-LB (6.8-8.1 Nm)	2
14	E110569	ROULEMENT 20 MM (6204)	1
15	E110571	BIELLE, TROUSSE DE 1	2
16	E110570	JOINT ÉTANCHE À L'HUILE	1
17	E110574	ROULEMENT 25 MM (6205)	1
18	E110575	ASSEMBLAGE DE PISTON, TROUSSE DE 2	2
19	E110576	JOINT ÉTANCHE À L'HUILE	1
20	E110577	DÉFLECTEUR	1
21	E110578	ROULEMENT, PROTECTEUR	1
22	E110579	VIS M6 X 1 X 16 MM TÊTE HEX ÉPAULEMENT, DENTELÉE, TROUSSE DE 4 - COUPLE 140-160 PO-LB (15.8-18 Nm)	4
23	E113222	CONNECTEUR NPT 1/2 PO X TUYAU 1/2 PO — COUPLE DE 15-25 PI-LB (20-34 Nm)	1
24	E114247	ASSEMBLAGE DE TUBES D'AÉRATION - COUPLE 20-25 PO-LB (2.2-2.8 Nm)	1

Lista de las piezas - DXCM602

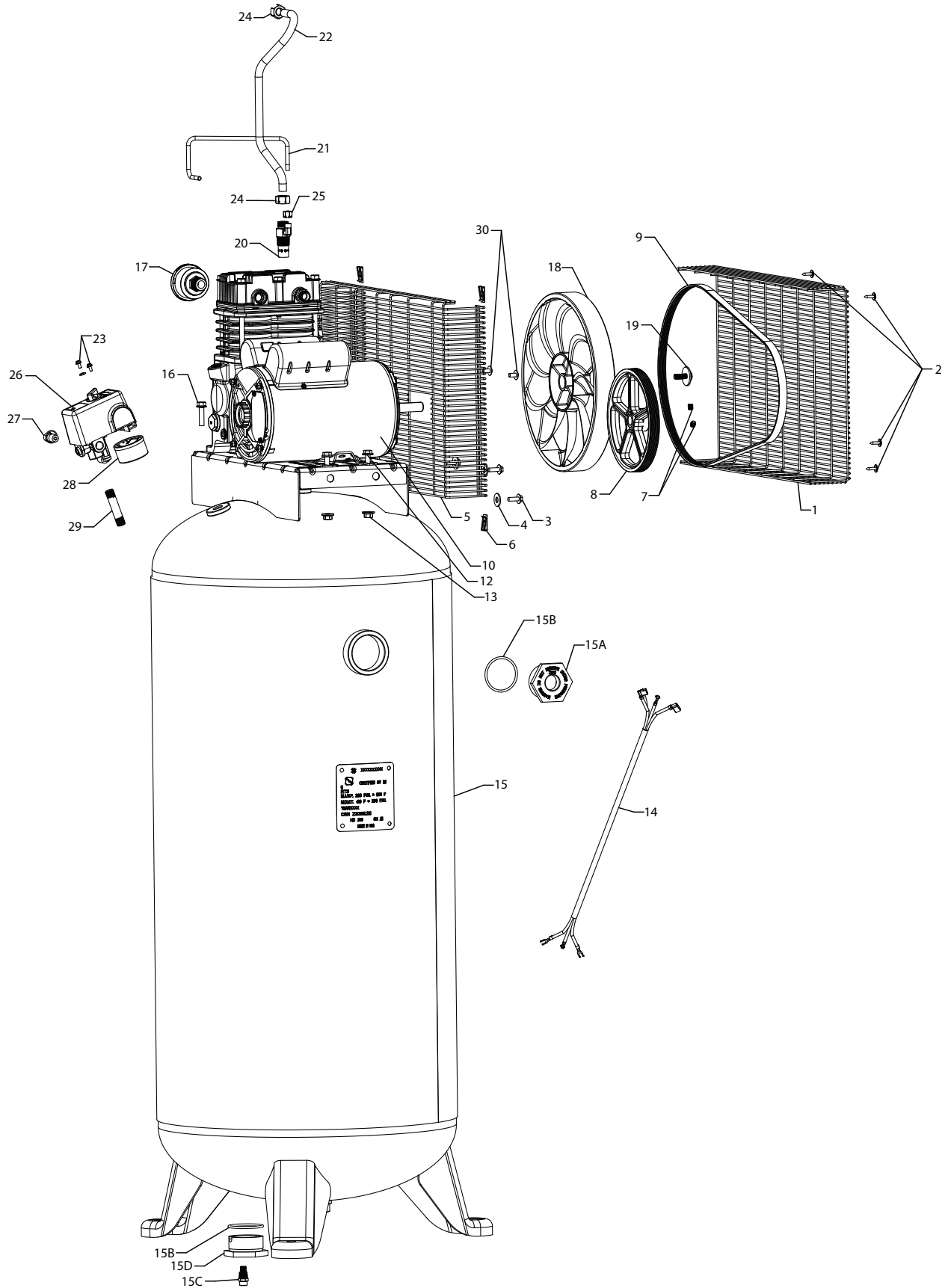

Lista de las piezas - DXCM602

NO° REF	NO° PIEZA	DESCRIPCIÓN	CANT
1	E110660	PROTECTOR DE CORREA (EXTERIOR)	1
2	E110883	KIT DE TORNILLOS M5 X 0.8 X 20 MM - TORQUE 8-15 IN-LBS (1-1.7 Nm)	4
3	E106611	TORNILLO CABEZA HEX DE RESALTO ¼ pulg. - 18 x 3/4pulg. - TORQUE 40-50 IN-LBS (4.5-5.6 Nm)	3
4	E110549	ARANDELA 3/8 pulg. DIÁM. INT. X 7/8 pulg. DIÁM. EXT. X .105 THK	3
5	E110587	PROTECTOR DE CORREA (INTERIOR)	1
6	E106733	TUERCA DE SEGURIDAD TIPO "U" - M5 X .8 - EXTRUDIDO	4
7	E110558	KIT DE TORNILLOS DE AJUSTE 5/16 pulg. -18 X 3/8 pulg. - TORQUE 120-130 IN-LBS (13.6-14.7 Nm)	2
8	E110537	KIT DE POLEA 6.923 DIÁM. EXT. X 5/8 pulg. AGUJERO - INCLUYE PZAS # 7 y 11	1
9	E110538	CORREA POLI EN "V" - 6 RANURAS / TENSIÓN DE CORREA ~160Hz	1
10	VEA LA INSERCIÓN	MOTOR	1
11	E110547	LLAVE 3/16 pulg. X 3/16 pulg. X 1-3/8 pulg. (NO ILUSTRADAS)	1
12	E108112	TORNILLO 5/16 pulg. - 18 X ¾ pulg. - TORQUE 20-25 FT-LBS (27-32 Nm)	4
13	E108113	TUERCA 5/16 pulg.- 18 HEX RESALTO, DENTADO, KIT DE 5	4
14	E105991	MOTOR, CORDÓN ELÉCTRICO	1
15	E113365	CONJUNTO DE TANQUE, PINTADO	1
15A	E106539	ANILLO 2 pulg. NPSM X ¾ pulg. NPTF	1
15B	E105995	ANILLO "O" 2 pulg, KIT DE 2	2
15C	E109170	VÁLVULA DE DRENAJE ¼ pulg. NPT	1
15D	E105994	ANILLO 2 pulg. NPSM X ¼ pulg. NPTF	1
16	E110550	TORNILLO CABEZA HEX DE RESALTO 5/16 pulg. - 18 x 1 ¼ pulg. - TORQUE 15-20 FT-LBS (20-27 Nm)	4
17	E105207	FILTRO DE ENTRADA DEL AIRE 1/2 pulg. NPT	1
18	E110540	VOLANTE DE COMPRESOR 12 pulg.	1
19	E110541	TORNILLO SEMS (con arandela) M8 X 1.25 X 25 MM - TORQUE 20-24 FT-LBS (27-32 Nm)	1
20	E106027	VÁLVULA DE RETENCIÓN ½ pulg. NPT X ½ pulg. TUBO DIÁM. EXT.	1
21	E106001	TUBE DE ALIVIO DE PRESIÓN - ¼ pulg.	1
22	E113329	CONJUNTO DE TUBOS DE SALIDA - ½ pulg.- INCLUYE PZA. 24- TORQUE 100-200 IN-LBS (11.3-22.6 Nm)	1
23	E106643	TORNILLO DE TIERRA #8-32 x 3/8 pulg., KIT DE 2	2
24	E106641	TUERCA DE COMPRESIÓN ½ pulg. DIÁM. EXT. PARA TUBO - TORQUE 100-200 IN-LBS (11.3-22.6 Nm)	2
25	E105999	TUERCA DE COMPRESIÓN ¼ pulg. DIÁM. EXT. PARA TUBO - TORQUE 35-65 IN-LBS (4-7 Nm)	1
26	E106003	INTERRUPTOR DE PRESIÓN 1000-1207 kPa / 145-175 PSI	1
27	E108520	VÁLVULA DE DESCARGA DE SEGURIDAD 200 PSI	1
28	E106005	MANÓMETRO 2 pulg. - 300 PSI ¼ pulg. - 18 NPT	1
29	E110559	BOQUILLA ¼ pulg. NPT-18 X 2.50 pulg.	1
30	E108246	TORNILLO CON CABEZA REDONDA ¼ pulg. - 20 X ½ pulg. - TORQUE 45-60 IN-LBS (5-6.8 Nm)	2
31	E110586	ALMOHADILLAS ANTI-VIBRACIÓN (NO ILUSTRADAS), KIT DE 4	3
32	E106631	ETIQUETA DE ADVERTENCIA (NO ILUSTRADAS)	1
33	E106630	ETIQUETA DE ADVERTENCIA -SUPERFICIE CALIENTE (NO ILUSTRADAS)	1

Dibujo de piezas - Bomba - DXCM602

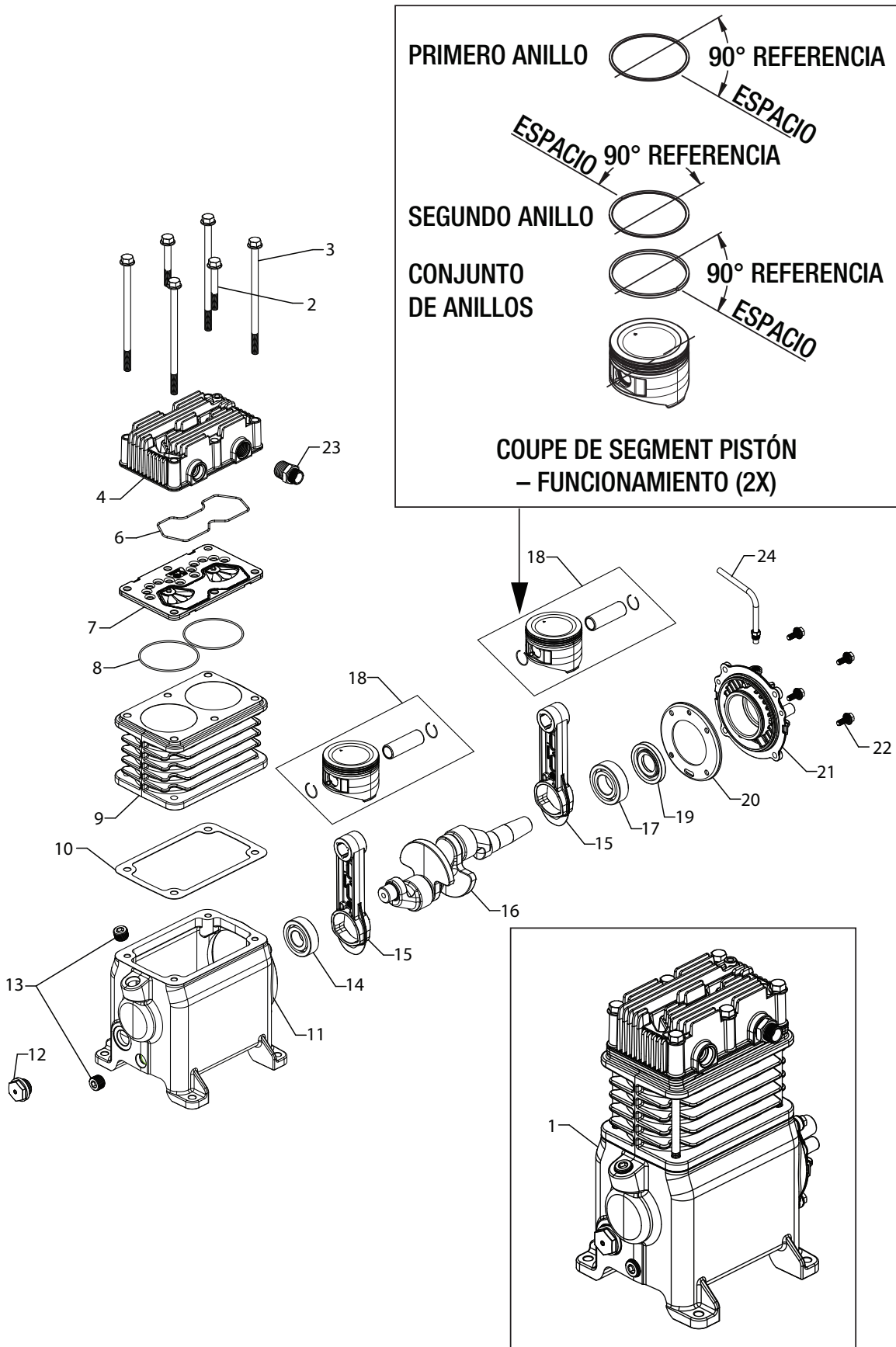

Lista de piezas - Bomba - DXCM602

NO° REF	NO° PIEZA	DESCRIPCIÓN	CANT
1	E113242	BOMBA I11 CON PUERTO DE ESCAPE ROSCADO	1
2	E110560	TORNILLO M8 X 1.25 X 60 MM CABEZA HEX RESALTO, KIT DE 2 - TORQUE 15-20 FT-LBS (20-27 Nm)	2
3	E110561	TORNILLO M8 X 1.25 X 150 MM CABEZA HEX RESALTO, KIT DE 2 - TORQUE 15-20 FT-LBS (20-27 Nm)	4
4	E113241	BOMBA DE ALTURA CON PUERTO DE ESCAPE ROSCADO	1
5	E110580	KIT DE JUNTAS QUE INCLUYE LAS PIEZAS 6,8,10,12,19 Y 20	1
6	E110563	ANILLO "O", FORMADO	1
7	E110564	CONJUNTO, PLACA DE VÁLVULA	1
8	E110565	ANILLO "O", KIT DE 2	2
9	E110566	CILINDRO	1
10	E110567	JUNTA	1
11	E110568	CÁRTER	1
12	E110542	MIRILLA, ACEITE - TORQUE 40-50 IN-LBS (4.5-5.6 Nm)	1
13	E110543	TAPÓN 3/8" NPT, KIT DE 2 - TORQUE 60-72 IN-LBS (6.8-8.1 Nm)	2
14	E110569	COJINETE 20 MM (6204)	1
15	E110571	BIELA, KIT DE 1	2
16	E110570	CIGÜEÑAL	1
17	E110574	COJINETE 25 MM (6205)	1
18	E110575	ENSAMBLAJE DE PISTÓN, KIT DE 2	2
19	E110576	SELLO DE ACEITE	1
20	E110577	DEFLECTOR	1
21	E110578	COJINETE, PROTECTOR	1
22	E110579	TUERCA M6 X 1 X 16 MM CABEZA HEX RESALTO, DENTADO, KIT DE 4 - TORQUE 140-160 IN-LBS (15.8-18 Nm)	4
23	E113222	CONECTOR NPT DE 1/2" X TUBO DE 1/2" - TORQUE 15-25 FT-LB (20 - 34 Nm)	1
24	E114247	ENSAMBLAJE DE TUBOS DE AIREACIÓN - TORQUE 20-25 IN-LB (2.2-2.8 Nm)	1