

# 6898-10159 2-Tier Garment Rack ©2019 Whitmor, Inc.

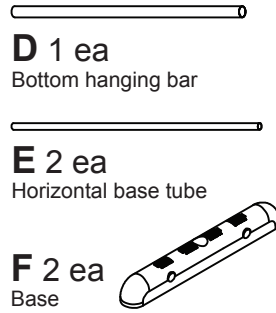
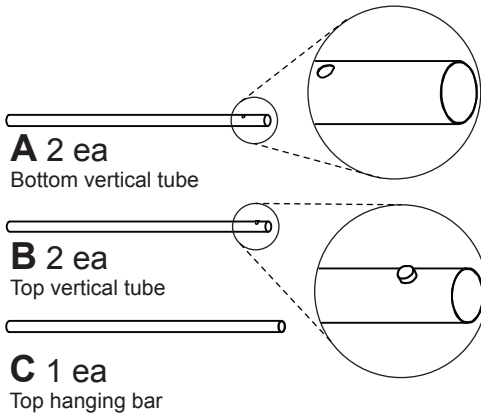

Part	Reference
A	F10250
B	F10251
C	F10253
D	F10254
E	F10252
F	F10249
G	F10255
H	F10256
I	F10257
J	F10258

**Tools Needed:**  
No tools required.

**NOTE:** Wheels should be inserted last.

**STEP 1:** Start by assembling the base. Insert two horizontal base tubes (E) into two bases (F).

**STEP 2:** Firmly insert bottom vertical tubes (A) into the base, make sure the pinholes are on top and facing each other.

**STEP 3:** Insert bottom hanging bar (D) into two middle connectors (H).

**STEP 4:** Place assembled hanging bar section on bottom vertical tubes (A).

**STEP 5:** Slide top vertical tube (B) through middle connectors (H) into the pinholes at the top of bottom vertical tubes (A). Align pinhead with the pinhole, press on pinhead and push until locked.

**STEP 6:** Insert top hanging bar (C) into the corner connectors (G).

**STEP 7:** Place assembled top horizontal bar section on tubes (B) and press down firmly.

**STEP 8:** Insert wheels (I) and (J) into bottom of base.

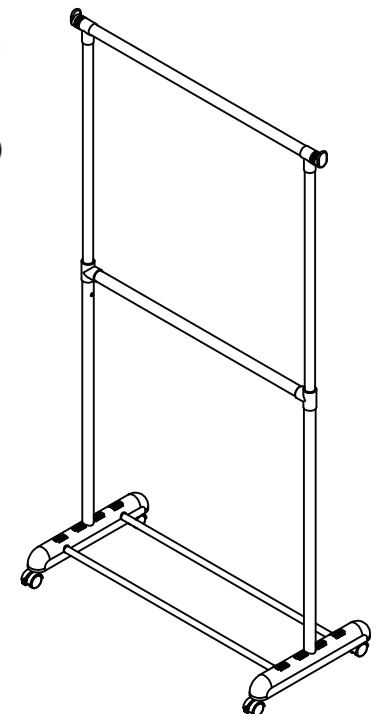
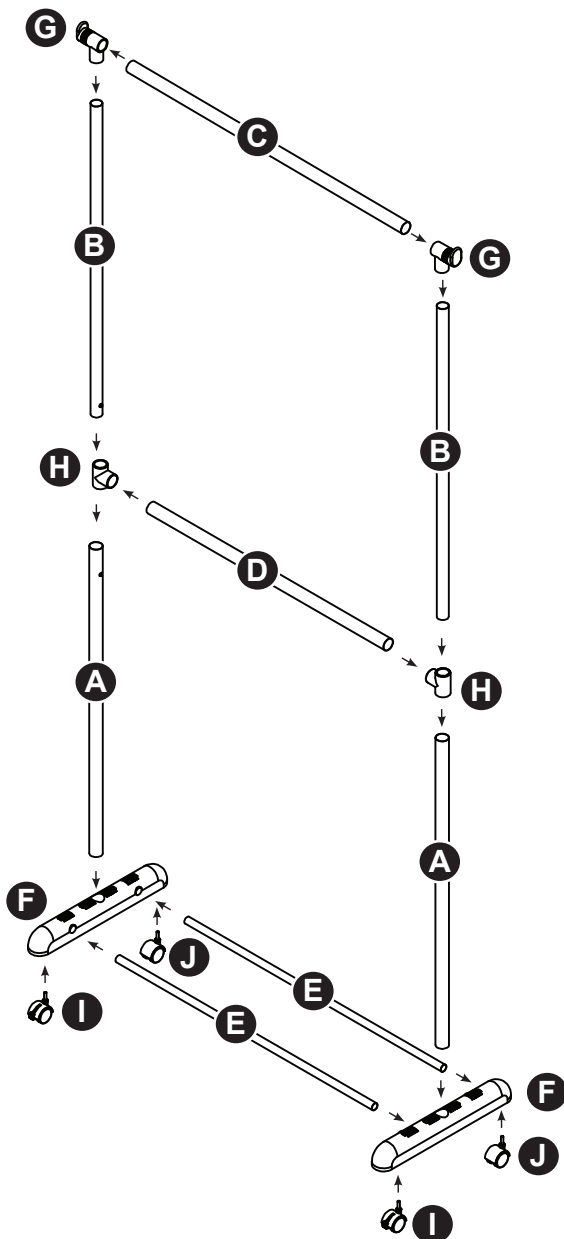

8680 Swinnea Road • Suite 103 • Southaven, MS • 38671

**NEED HELP?** For help with assembly, or if you are missing a part, please call Whitmor's Customer Service Department, 1-888-944-8667 between 8 a.m. and 4:30 p.m. (Central Standard Time) Monday through Friday. Or email: [help@whitmor.com](mailto:help@whitmor.com). Visit us online at [www.whitmor.com](http://www.whitmor.com)