



230V 195AMP DUAL MIG195 WELDING WELDER

ITEM: 55016



OWNER'S MANUAL AND SAFETY INSTRUCTIONS

SAVE THIS MANUAL: KEEP THIS MANUAL FOR SAFETY WARNINGS, PRECAUTIONS, ASSEMBLY, OPERATING, INSPECTION, MAINTENANCE AND CLEANING PROCEDURES. WRITE THE PRODUCT'S SERIAL NUMBER ON THE BACK OF THE MANUAL NEAR THE ASSEMBLY DIAGRAM (OR MONTH AND YEAR OF PURCHASE IF PRODUCT HAS NO NUMBER).

FOR QUESTIONS PLEASE CALL OUR CUSTOMER SUPPORT: (909) 628 4900 MON-FRI 9AM TO 3PM PST

IMPORTANT SAFETY INFORMATION



GENERAL SAFETY WARNINGS

Read all safety warnings and instructions. Failure to follow the warnings and instructions may result in electric shock, fire and/or serious injury. Save all warnings and instructions for future reference.

SAFETY

The warnings, precautions, and instructions discussed in this instruction manual cannot cover all possible conditions and situations that may occur. It must be understood by the operator that common sense and caution are factors which cannot be built into this product, but must be supplied by the operator. Read carefully and understand all ASSEMBLY AND OPERATIONC INSTRUCTIONS before operating. Failure to follow the safety rules and other basic safety precautions may result in serious personal injury.

- **Read and understand all instructions.** Failure to follow all instructions may result in serious injury or property damage.
- **DO NOT** allow persons to operate or assemble the product until they have read this manual and have developed a thorough understanding of how it works.
- **DO NOT modify this product in any way.** Unauthorized modification may impair the function and/or safety and could affect the life of the product. There are specific applications for which the product was designed.
- **Use the right tool for the job. DO NOT** attempt to force small equipment to do the work of larger industrial equipment. There are certain applications for which this equipment was designed. This product will be safer and do a better job at the capacity for which it was intended. **DO NOT** use this equipment for a purpose for which it was not intended.
- **Inspect the work area before each use.** Keep work area clean, dry, free of clutter, and well-lit. Cluttered, wet, or dark work areas can result in injury.
- **Keep children and bystanders away from the work area while operating this product. DO NOT** allow children to handle the product.
- Stay alert, watch what you are doing, and use common sense when operating the tool. **DO NOT** use the tool while you are tired or under the influence of drugs, alcohol, or medication.
- **Check for damaged parts before each use.** Carefully check that the product will operate properly and perform its intended function. Replace damaged or worn parts immediately. Never operate the product with a damaged part.
- **Wear the proper personal protective equipment when necessary.** Use ANSI Z87.1 compliant safety goggles (not safety glasses) with side shields. Leather leggings, fire resistant shoes or boots should be worn when using this product This applies to all persons in the work area. Keep clothing free of grease, oil, solvents, or any flammable substances Wear dry, insulating gloves and protective clothing.
- Always keep guards in position, in good working order, correctly adjusted and aligned. Never attempt to use a power tool without any guard supplied with it.

- Keep head out of fumes. **DO NOT** breathe exhaust fumes
- Use enough ventilation, exhaust at arc, or both, to keep fumes and gases from breathing zone and general area. If engineering controls are not feasible, use an approved respirator.
- Always check to see that keys and adjusting wrenches are removed from power tool before turning on.
- Standing on your power tool or its stand could cause serious injury if the tool is tipped or if the cutting tool is accidentally contacted. **DO NOT** store materials above or near the tool so that it is necessary to stand on the tool or its stand to reach them.
- **INHALATION HAZARD:** Exposure to welding or cutting exhaust fumes can increase the risk of developing certain cancers, such as cancer of the larynx and lung cancer. Also, some diseases that may be linked to exposure to welding or cutting exhaust fumes are: Early onset of Parkinson's Disease • Heart disease • Ulcers • Damage to the reproductive organs • Inflammation of the small intestine or stomach • Kidney damage • Respiratory diseases such as emphysema, bronchitis, or pneumonia. Use natural or forced air ventilation and wear a respirator approved by NIOSH to protect against the fumes produced to reduce the risk of developing the above illnesses.
- Feed work into a blade or cutter against the direction of rotation of the blade or cutter only.
- **DO NOT** touch energized electrical parts. Wear dry, insulating gloves. **DO NOT** touch electrode holder, electrode, welding torch, or welding wire with bare hand. **DO NOT** wear wet or damaged gloves.
- Connect to grounded, GFCI-protected power supply only.
- People with pacemakers should consult their physician(s) before use. Electromagnetic fields in close proximity to heart pacemaker could cause pacemaker interference or pacemaker failure.
- **DO NOT** expose welders to rain or wet conditions. Water entering a welder will increase the risk of electric shock.
- **DO NOT** abuse the cord. Never use the cord for carrying, pulling or unplugging the welder. Keep cord away from heat, oil, sharp edges or moving parts. Damaged or entangled cords increase the risk of electric shock.
- Insulate yourself from the work piece and ground. Use non-flammable, dry insulating material if possible, or use dry rubber mats, dry wood or plywood, or other dry insulating material large enough to cover your full area of contact with the work or ground.
- Clear away or protect flammable objects. Remove or make safe all combustible materials for a radius of 35 feet (10 meters) around the work area. Use a fire resistant material to cover or block all open doorways, windows, cracks, and other openings.
- **ALWAYS** keep a fire extinguisher nearby whenever operating the machine.
- **DO NOT** operate welders in atmospheres containing dangerously reactive or flammable liquids, gases, vapors, or dust. Provide adequate ventilation in work areas to prevent accumulation of such substances. Welders create sparks which may ignite flammable substances or make reactive fumes toxic.
- If working on a metal wall, ceiling, etc., prevent ignition of combustibles on the other side by moving the combustibles to a safe location.

- **DO NOT** weld or cut on materials having a combustible coating or combustible internal structure, as in walls or ceilings, without an approved method for eliminating the hazard.
- **DO NOT** dispose of hot slag in containers holding combustible materials.
- After welding, make a thorough examination for evidence of fire. Be aware that easily visible smoke or flame may not be present for some time after the fire has started.
- **DO NOT** apply heat to a container that has held an unknown substance or a combustible material whose contents, when heated, can produce flammable or explosive vapors. Clean and purge containers before applying heat. Vent closed containers, including castings, before preheating, welding, or cutting.
- **DO NOT** use the welder if the switch does not turn it on and off. Any welder that cannot be controlled with the switch is dangerous and must be repaired.
- Disconnect the plug from the power source before making any adjustments, changing accessories, or storing welders. Such preventive safety measures reduce the risk of starting the welder accidentally.
- Prevent unintentional starting. Ensure the switch is in the off position before connecting to power source or moving the welder.
- Store idle welders out of the reach of children and do not allow persons unfamiliar with the welder or these instructions to operate the welder.
- Use the welder and accessories in accordance with these instructions, taking into account the working conditions and the work to be performed. Use of the welder for operations different from those intended could result in serious injury or property damage.
- **DO NOT** use the welder for pipe thawing.
- Maintain welders. Check for misalignment or binding of moving parts, breakage of parts and any other condition that may affect the welder's operation. If damaged, have the welder repaired before use.
- Have your welder serviced by a qualified repair person using only identical replacement parts.
- Maintain labels and nameplates on the Welder. These carry important information. If unreadable or missing, contact Stark Tools for a replacement.
- Unplug the Welder from its electrical outlet before any inspection, maintenance, or cleaning procedures.
- **NEVER** weld on a pressurized or a closed cylinder.
- **NEVER** allow an electrode holder, electrode, welding torch, or welding wire to touch the cylinder.
- Keep cylinders away from any electrical circuits, including welding circuits.
- Keep protective cap in place over the valve except when the cylinder is in use.
- Use only correct gas shielding equipment designed specifically for the type of welding you will do.
- Protect gas cylinders from heat, being struck, physical damage, slag, flames, sparks, and arcs.
- **ALWAYS** use proper procedures to move cylinders.

**SAVE THESE INSTRUCTIONS.**

SPECIFICATIONS AND IMPORTANT INFORMATION

1. ON/OFF SWITCH
2. OUTPUT SETTINGS
3. AMP SELECTOR
4. EARTH CLAMP
5. TORCH

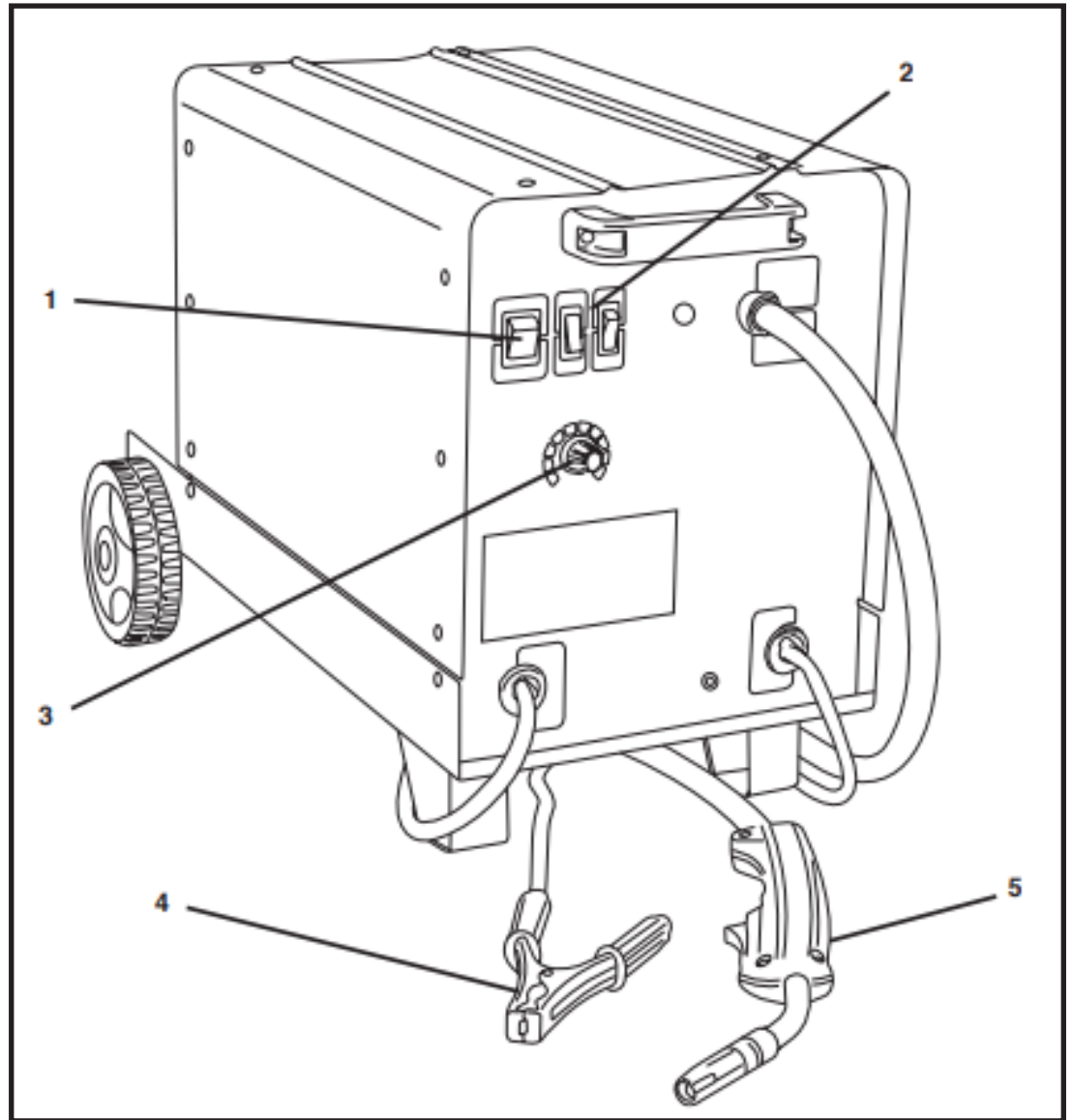

FEATURES

- Variable Feed Speed Control
- Torch With Full On / Off Safety Control
- Automatic Thermal Safety Protection
- Simple to operate-fan cooled
- Easily converted to gas operation
- Weld mild steel, aluminum, stainless steel and cast iron

CONTENTS

- 1X welder machine
- 1X welding gun
- 1X Welding Wire
- 1X welding mask
- 1X hammer brush
- 1X torch
- 1X ground cord with clamp

SPECIFICATIONS

- Input voltage: 230V/60Hz AC, single phase
- Welding current: 60 to 190 amps
- Duty cycle: 10% @ 180amps, 60% @ 74amps, 100% @ 60 amps
- Max open circuit voltage: 37v
- Wire capacity: 0.031 (0.8mm) steel & stainless steel, 0.030" to 0.039" (1.0mm) aluminum, 0.047(1.2mm) flux core

OPERATION

ELECTRICAL SAFETY INFORMATION

The wires in this product are color coded:

- **BLUE:** Neutral (N)
- **BROWN:** Live (L)
- **GREEN/YELLOW:** Earth (E)

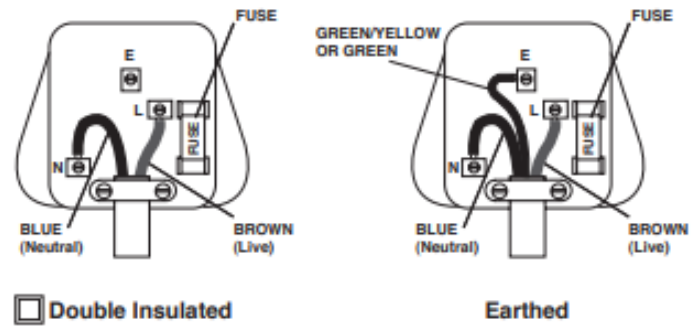

- As the colours may not correspond with the coloured markings identifying the terminals in your plug, proceed as follows.
- The wire which is coloured blue must be connected to the terminal which is marked with the letter N or coloured black, the wire which is coloured brown must be connected to the terminal which is marked L or coloured red.
- This appliance must be protected by a suitable fuse.
- To prevent fire or shock hazard, do not expose this product to rain/water or moisture. There are no user serviceable parts inside except those referred to in this manual. Always refer servicing to qualified service personnel. Never remove any part of the casing unless qualified to do so; this unit contains dangerous voltages.
- Use of a residual current device (RCD) will reduce the risk of electric shock.

NEVER CONNECT THE BROWN OR BLUE WIRE TO THE EARTH PIN OF THE 13 AMP PLUG. IF IN DOUBT CONSULT A QUALIFIED ELECTRICIAN.

THE FOLLOWING INSTRUCTIONS REFER ONLY TO MACHINES WHICH USE GAS.

- Cylinder mounting brackets should be fitted to the rear of the machine (where provided)
- Connect the gas tube by pushing the free end into the connector on the regulator.
- To fit the gas cylinder to the regulator remove the cover from the cylinder thread, and carefully screw on the regulator, gas will escape until the regulator is fully fitted. Important always remove the gas cylinder from the regulator when you have finished welding.
- To set the gas flow regulator turn the knob fully clockwise and then anti-clockwise half to one turn depending on welding conditions.
- Voltage settings, the machine will have either two or four output settings depending on the model. These are controlled by the switches on the front panel (see fig. A). Switching from one setting to another automatically increases or decreases the wire speed and therefore weld output. On materials from 0.6mm to 1.3mm select 'low' settings and 'high' for thicker materials.

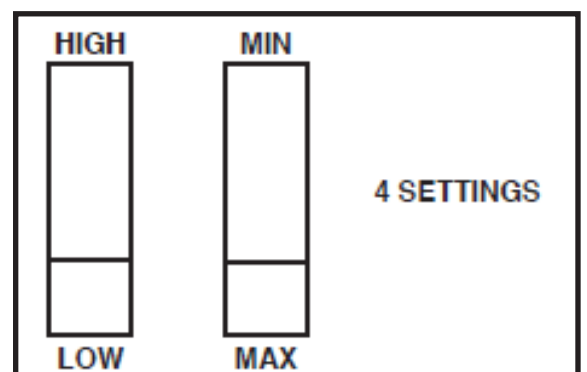
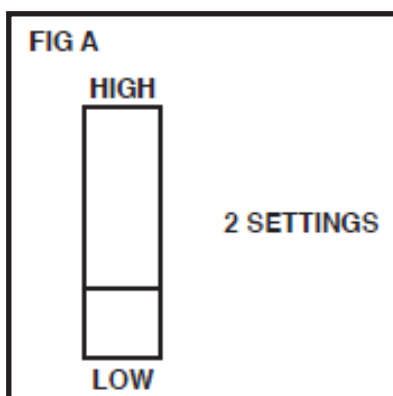

TROUBLESHOOTING

Weld deposit too thick	Welding voltage too low
	Torch moved over the work piece too slowly
Weld deposit incomplete and stringy	Gas flow incorrect
	Torch moved over the work piece too quickly
Arc unstable, excessive spatter and weld porosity	Rust, paint or grease on the work piece
	Torch held too far from the work piece
	No gas - check bottle content, connections regulator settings
	Incorrect gas for material
Wire repeatedly burns back	Torch held too close to the work piece
	Break in the welding circuit
	Incorrect size of contact tip for wire
	Contact tip damaged - replace
	Contact tip loose - tighten
	Feed rollers worn - replace
	Welding wire corroded - replace
	Pressure roller adjustment incorrect - adjust
	Pressure roller sticking - lubricate or replace
	Wire tangled on reel
Lack of weld penetration	Welding output too low
	Wire feed speed too low
	Torch moved too fast
Burning holes in work piece	Welding output too high
	Torch moved erratically or too slowly
No arc produced	Earth lead or torch cable in open circuit
	Poor earth clamp connection
Welder does not operate (mains indicator not lit).	Check mains connection
	Check supply fuse
Welder does not operate with trigger pressed.	Check torch trigger and its connections
	Thermal overload cut out - allow to cool

PLEASE READ THE FOLLOWING CAREFULLY

THE MANUFACTURER AND/OR DISTRIBUTOR HAS PROVIDED THE PARTS LIST AND ASSEMBLY DIAGRAM IN THIS MANUAL AS A REFERENCE TOOL ONLY. NEITHER THE MANUFACTURER OR DISTRIBUTOR MAKES ANY REPRESENTATION OR WARRANTY OF ANY KIND TO THE BUYER THAT HE OR SHE IS QUALIFIED TO MAKE ANY REPAIRS TO THE PRODUCT, OR THAT HE OR SHE IS QUALIFIED TO REPLACE ANY PARTS OF THE PRODUCT. IN FACT, THE MANUFACTURER AND/OR DISTRIBUTOR EXPRESSLY STATES THAT ALL REPAIRS AND PARTS REPLACEMENTS SHOULD BE UNDERTAKEN BY CERTIFIED AND LICENSED TECHNICIANS, AND NOT BY THE BUYER. THE BUYER ASSUMES ALL RISK AND LIABILITY ARISING OUT OF HIS OR HER REPAIRS TO THE ORIGINAL PRODUCT OR REPLACEMENT PARTS THERETO, OR ARISING OUT OF HIS OR HER INSTALLATION OF REPLACEMENT PARTS THERETO.

Record Product's Serial Number Here: _____

Note: If product has no serial number, record month and year of purchase instead.

Note: Some parts are listed and shown for illustration purposes only and are not available individually as replacement parts.



Questions, problems, missing parts?

Before returning to your retailer, our exceptional customer service is available.

Call us Tel: **909 628 4900**

Hour : **9am To 3pm PST (Monday to Friday)**

Email : **info@starktoolsusa.com**