

# Oasis Eclipse Mailbox (Model 6400) Instructions

If you have any questions about how to mount or use this mailbox, or if you need any replacement parts, please call us directly at (310) 374-5700 or contact us at support@architecturalmailboxes.com.

## Mounting Instructions

Your new mailbox comes completely assembled. To begin using your mailbox, it must be properly mounted in accordance with USPS requirements to facilitate carrier access, described below. You can mount your mailbox on one of the optional mailbox posts we offer (sold separately), or you can mount it to a wooden post using the optional 4X4 Adapter (item 7540B-10; also sold separately).

CUSTOMERS ARE REQUIRED TO CONTACT THE LOCAL POST OFFICE BEFORE INSTALLING THE MAILBOX TO ENSURE ITS CORRECT PLACEMENT AND HEIGHT AT THE STREET. GENERALLY, MAILBOXES ARE INSTALLED AT A HEIGHT OF 41-45 INCHES FROM THE ROAD SURFACE TO INSIDE FLOOR OF THE MAILBOX OR POINT OF MAIL ENTRY (LOCKED DESIGNS) AND ARE SET BACK 6-8 INCHES FROM THE FRONT FACE OF CURB OR ROAD EDGE TO THE MAILBOX DOOR.

1

**For 3" Round In-ground Post (item 7507 or 7516) or Standard In-ground Post (item 5105 or 5525):** Dig a hole deep enough to allow the box to sit at the specified height, as required by your local post office. The height from the road level to the mailbox floor is typically between 41 and 45 inches. Make sure the hole is set back from the road such that the distance from the curb or the road edge to the mailbox face meets local post office requirements, typically between 6 and 8 inches.

**For Standard Surface Mount Post item 5526:** If using j-bolts, dig a hole deep enough to properly support the box (about 18") and to allow the box to sit at the specified height. If using concrete anchors in preexisting concrete, make sure the anchor positions allow the box to sit at the specified height. Also, make sure the bolt or anchor positions allow for the specified set-back, typically 6 to 8 inches from curb.

2

**For 3" Round In-ground Post (item 7507 or 7516) or Standard In-ground Post (item 5105 or 5525):** Pour the concrete (at least 1 cubic foot recommended) completely around the post, making sure the post and mailbox are level and correctly positioned according to your local post office.

**For Standard Surface Mount Post (item 5526):** Pour concrete around j-bolts held in the correct pattern, or install anchors in the correct pattern into dry concrete.

3

**For 3" Round In-ground Post (item 7507 or 7516), or Standard Posts (items 5105, 5525 or 5526):** Attach the mailbox to the post using the hardware included with the post.

**Note - If you are using a mounting method other than one of our optional post (items 5105, 5525, 5526, 7507 or 7516):** The mailbox has mounting bolt patterns on the bottom that are designed to provide adequate mounting strength and stability for long term use. Do not drill new mounting holes into the mailbox floor. Instead, create a bracket to attach the mailbox to the post using the existing holes in the mailbox floor. Drilling new holes or modifying the mailbox in any way may compromise the function, strength or corrosion resistance of the product, and void the warranty.

4

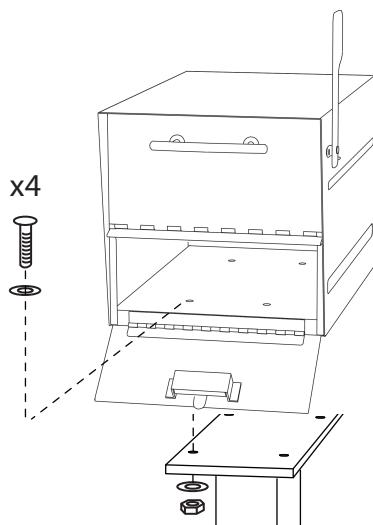

Attach the mailbox to the post using the hardware included with the post.



**NOTE:** The mounting hardware to attach this mailbox to your existing post or to a post from another manufacturer is not included. Compatible mounting hardware is included with all Architectural Mailboxes posts, sold separately.



ARCHITECTURAL  
MAILBOXES®

www.architecturalmailboxes.com (310) 374-5700

# Oasis Eclipse Mailbox (Model 6400) Instructions

## Using your new mailbox

**INCOMING DELIVERIES** - Your Oasis Eclipse Mailbox is designed to accept delivery of mail and small parcels. This mailbox provides some security until you are able to retrieve your deliveries at the end of the day. Although this box is locking and provides a front line deterrent for thieves, it is not a safe and you should take reasonable precautions to make sure your deliveries remain secure. Here are some suggestions:

Do not leave mail in your box for extended periods of time. Collect your mail every day and do not leave it overnight.

Do not let your mail stack up in the receptacle.

When away for an extended period of time, request your local Post Office to hold your mail until you return. Your mail is safest behind the walls of your local Post Office.

If you are receiving very valuable or sensitive deliveries, consider a means for their delivery consistent with their nature, such as through registered mail or a trackable courier.

**KEYS** - Your new mailbox comes with two keys. Contact us directly if you need additional key blanks. To retrieve incoming deliveries, simply open the front access door. **IT IS IMPORTANT TO NOTE THAT IT IS NOT THE RESPONSIBILITY OF MAIL CARRIERS TO OPEN MAILBOXES THAT ARE LOCKED, ACCEPT KEYS FOR THIS PURPOSE, OR LOCK MAILBOXES AFTER DELIVERY OF THE MAIL.**

**OUTGOING MAIL** - If you want to leave mail for your carrier to pick up, place the mail under the outgoing clip and raise the flag. Upon your carrier's next delivery, he or she will retrieve your outgoing mail and lower the flag.

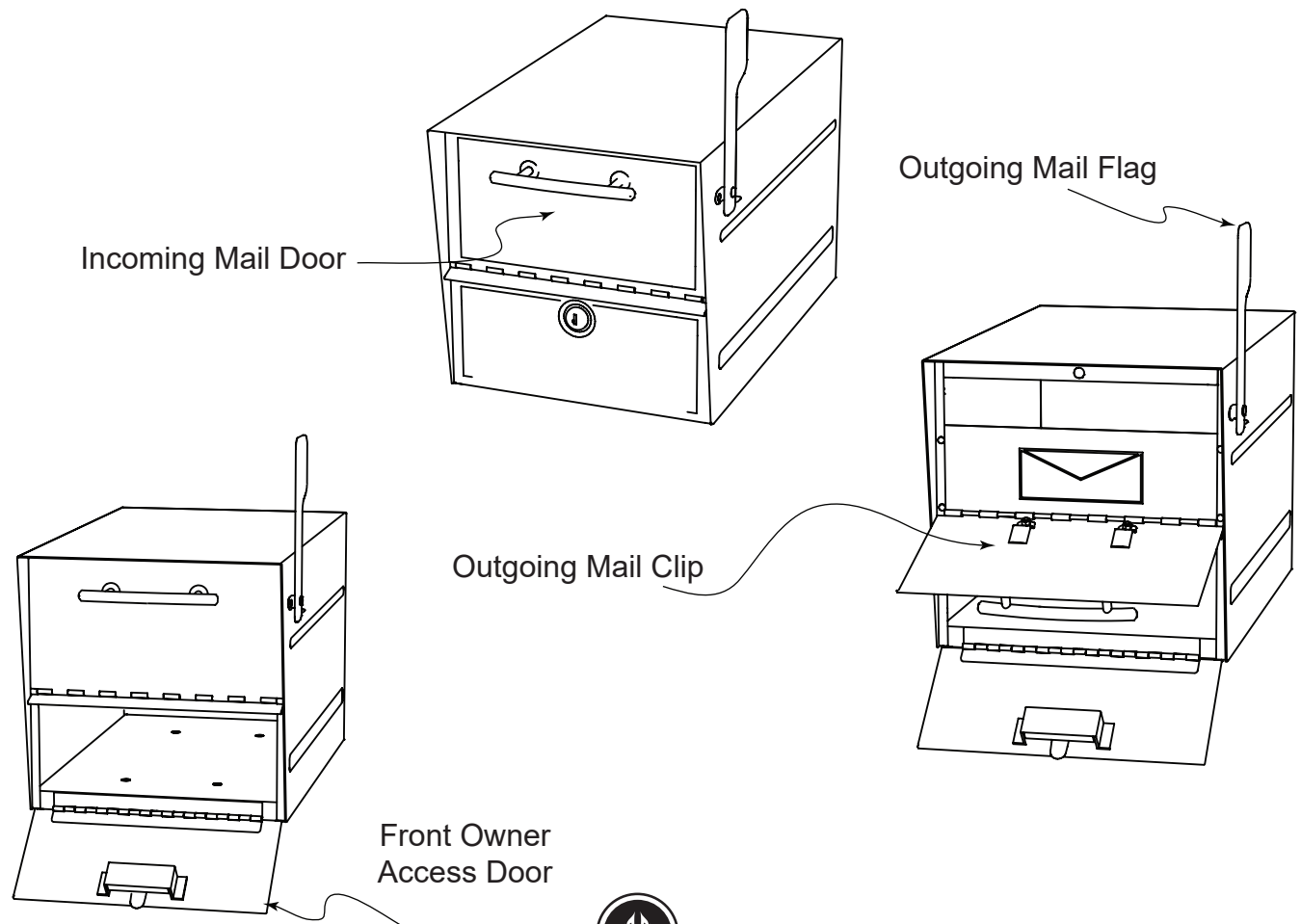

ARCHITECTURAL  
MAILBOXES®