

Installation Guide

Model: ML200/ML300 Series

Lock Body: American Standard Single Latch

Version: 1.1

English

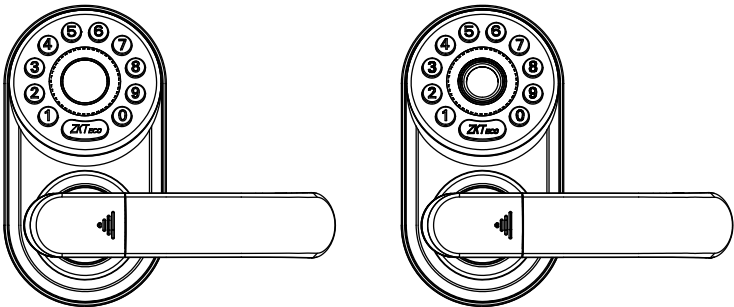

Important Notes

1. Please read this Installation Guide carefully or contact the Customer Care for any queries regarding installation.
2. Installation is recommended to be performed by a professional to avoid any additional service charges that may cause due to improper product installation.
3. We constantly revise the contents of this Installation Guide and update our products to improve the quality and performance without any prior notice.
4. Do not insert batteries before installing the lock.

Table of Contents

What's in the Box.....	1
Installation Diagram.....	2
Installation Procedure.....	2
1. Door Properties.....	2
2. *Drilling Holes on the Door.....	3
3. Installing Latch.....	4
4. Installing Outdoor Assembly.....	5
5. Installing Mounting Plate and Gasket.....	6
6. Installing Indoor Assembly.....	6
7. Installing Batteries and Cover.....	7
8. Installing Strike Plate and Box.....	8
9. Physical Testing.....	8

What's in the Box



Outdoor Assembly

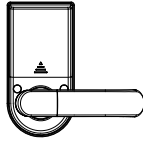

Indoor Assembly

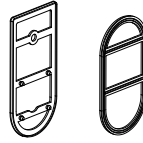

Gasket



Mounting Plate

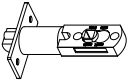

Latch

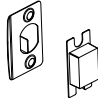

Strike Plate
and Box



Stud

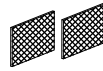

Double Sided
Tapes



Keys



Hex Wrench

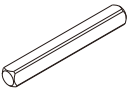

Spindle



Screw A



Screw B



Screw C



Screw D



Screw E

Door Thickness	Spindle	Screw B	Screw C
30 to 37 mm	56 mm	20 mm	25 mm
38 to 45 mm	64 mm	30 mm	35 mm
46 to 53 mm	72 mm	35 mm	40 mm
54 to 60 mm	80 mm	45 mm	50 mm

Note: Screws and Spindles for the doors of thickness from **30 to 60** mm are included in the standard package. Please use the appropriate set of Screws and Spindles as per your door's thickness, to assure the proper functioning of the lock.

Installation Diagram

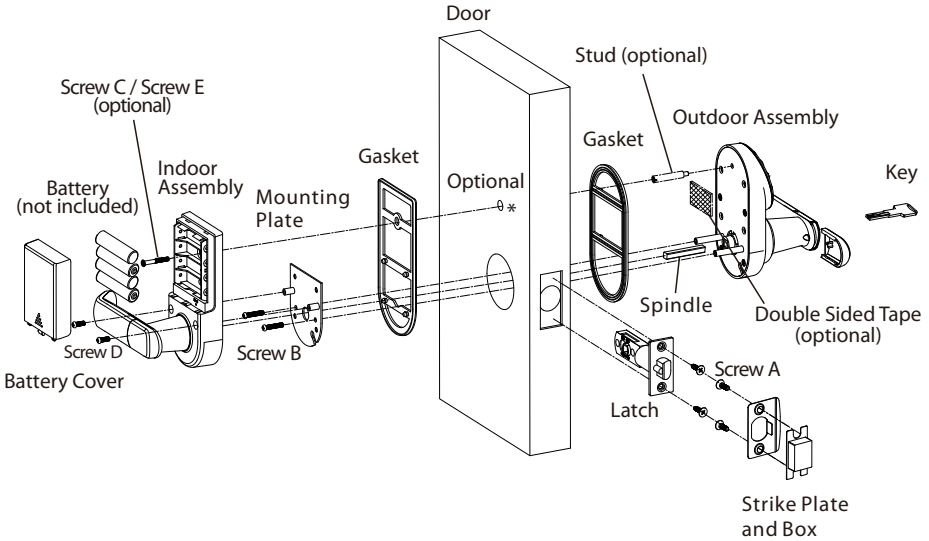

Important Notice

You can either use the provided Double Sided Tapes or Stud to stabilize the Outdoor Assembly. Stud requires drilling an extra hole.

Installation Procedure

1 Door Properties

A. Measure the door thickness

Measure the door thickness and select the proper Spindle and Screw length. For details, please refer to the table contents of Page 1.

B. Check the door opening direction

The position of the handle is determined by the opening direction of the door. Below is the graphical representation of door opening direction in reference to your location outside the room.

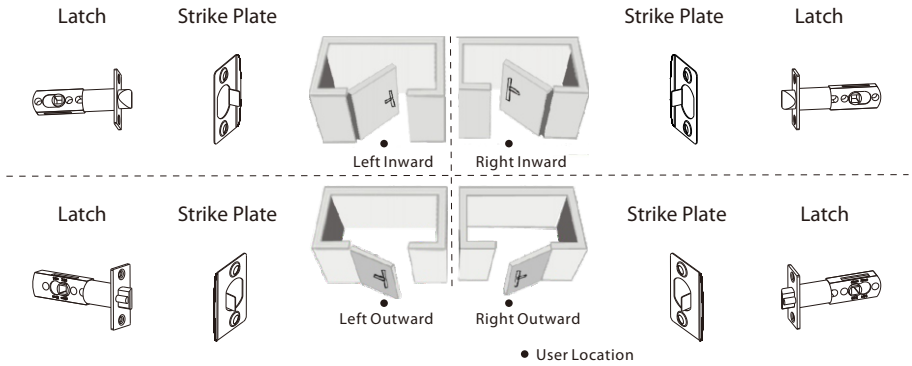

C. Change the handle direction (if needed)

- 1) Use the Hex Wrench to remove the Screw of the handle. Take the handle out from the lock.
- 2) Change the handle direction and place it again and fix it by using the Screw.

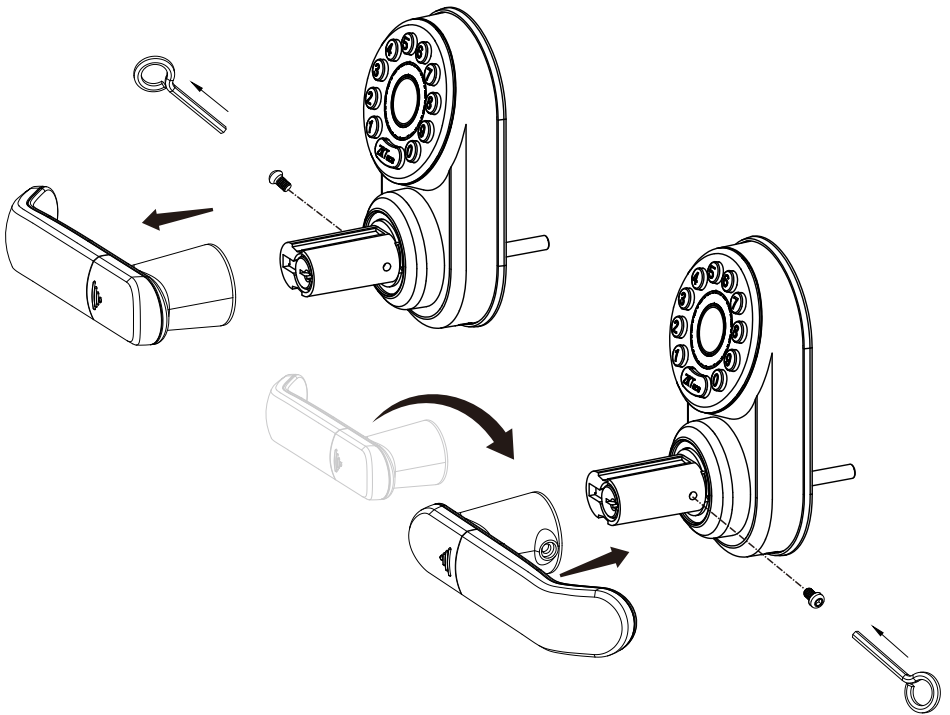

2 *Drilling Holes on the Door

- 1) Place the Installation Template at the desired handle height.
- 2) Mark for the holes to be drilled and drill the marked places.

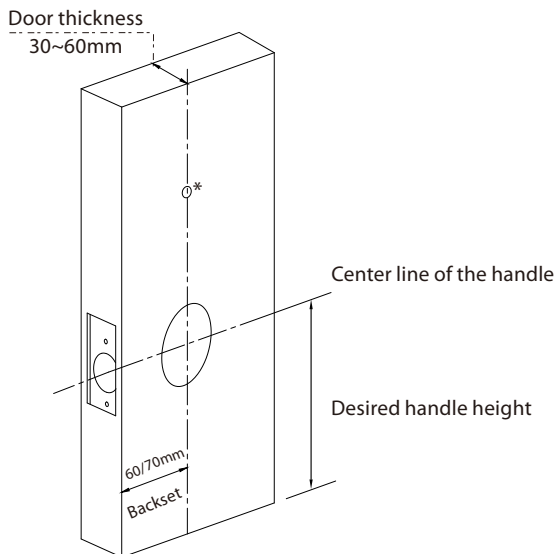

⚠ NOTE

- 1) * If you don't want to drill an extra hole on your door, you can just skip this step.
- 2) If you wish to have added stability, drill for the hole by referring to the provided Installation Template.

3 Installing Latch

- 1) Adjust the backset of the lock. (if needed)
- 2) Fix the Latch with the Screw A. Make sure the Latch angle faces the door jamb.

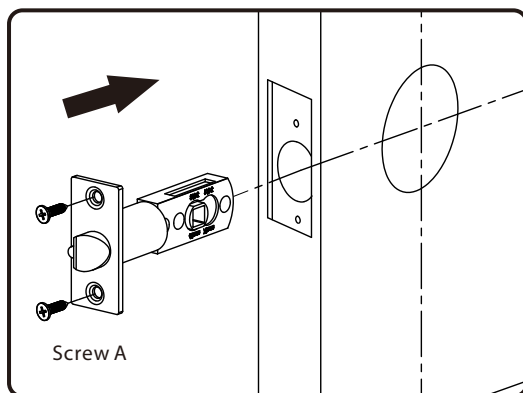
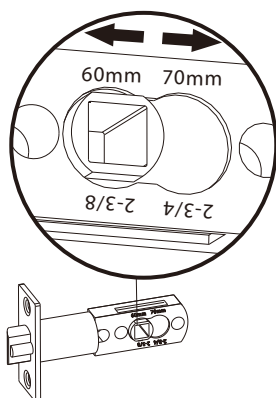

4 Installing Outdoor Assembly

There are two methods to install the Outdoor Assembly.

Method 1: Installing with Double Sided Tapes

- 1) Paste a Double Sided Tape on the Mounting Plate of the Outdoor Assembly.
- 2) Insert the Spindle into the clutch. **Make sure the triangle mark points to the vertically centred position.**
- 3) Attach the Outdoor Assembly to the door by inserting the cable through the drilled holes.

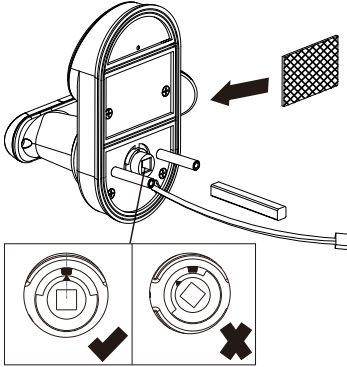

Clutch correct position:
The triangle must be vertically centered.

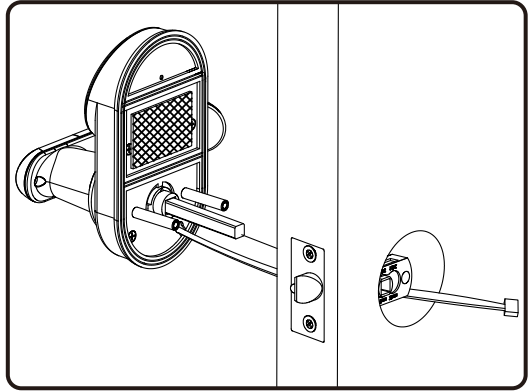

Method 2: Installing with Stud

- 1) Fix the Stud on the Mounting Plate of the Outdoor Assembly.
- 2) Insert the Spindle into the clutch. **Make sure the triangle mark points to the vertically centred position.**
- 3) Attach the Outdoor Assembly to the door by inserting the cable through the drilled holes.

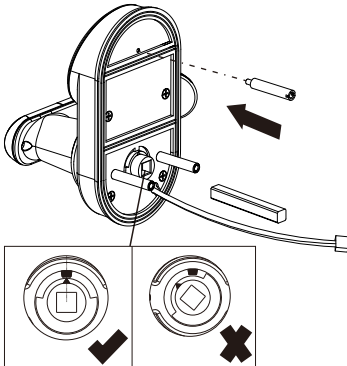

Clutch correct position:
The triangle must be vertically centered.

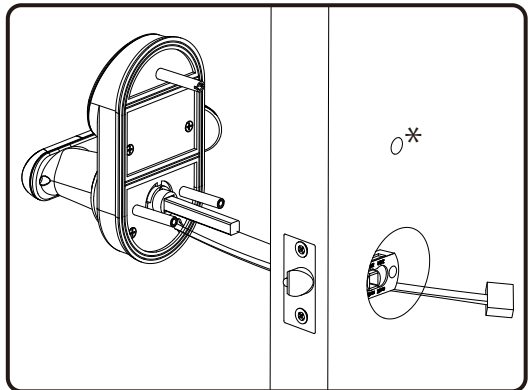

5 Installing Mounting Plate and Gasket

- 1) Attach the Mounting Plate to the Gasket and route the cable through the hole.
- 2) Place the Gasket and Mounting Plate on to the door and use Screw B to fix them.

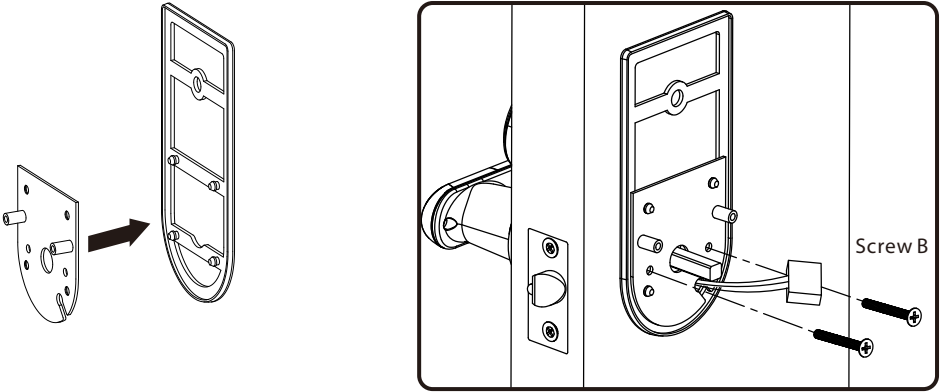

6 Installing Indoor Assembly

Select the **Indoor Assembly Installation** method according to the previously selected **Outdoor Assembly Installation** method in Step 4.

vMethod 1: Installing with Double Sided Tapes

- 1) Connect the cables to the port on the Indoor Assembly.
- 2) Place the Indoor Assembly properly on the Mounting Plate. Then use **Screw D & Screw E** to fix the Indoor Assembly.

Note: Fix the **Screw E** into the wooden door with the Screwdriver.

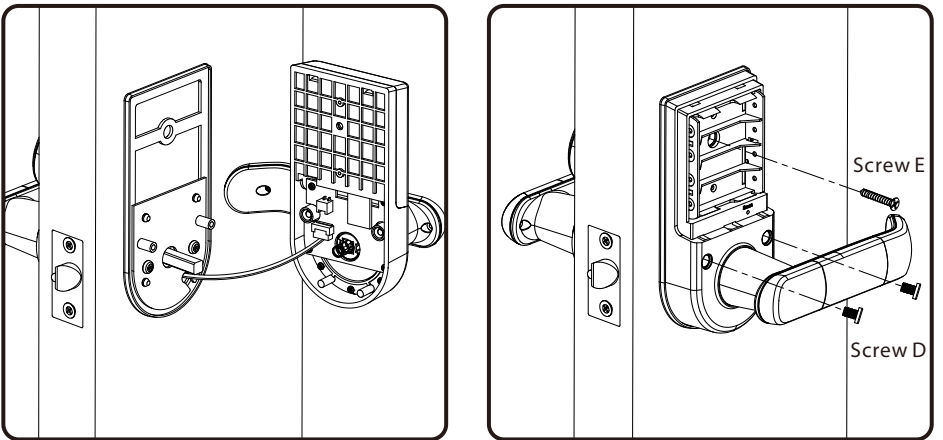

vMethod 2: Installing with Stud

- 1) Connect the cable to the port on the Indoor Assembly.
- 2) Place the Indoor Assembly properly on the Mounting Plate. Then use **Screw C** & **Screw D** to fix the Indoor Assembly.

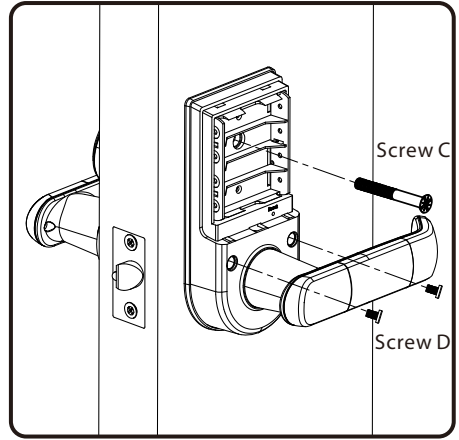
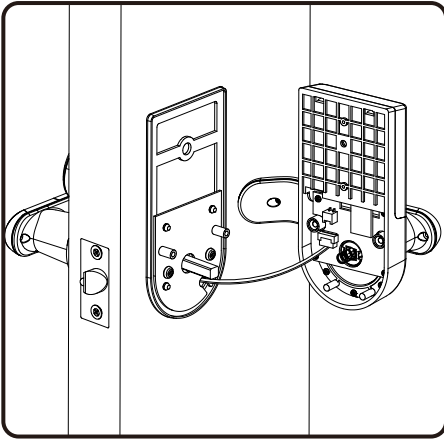

7 Installing Batteries and Cover

Insert four **Alkaline AA batteries** and cover them with a battery cover.

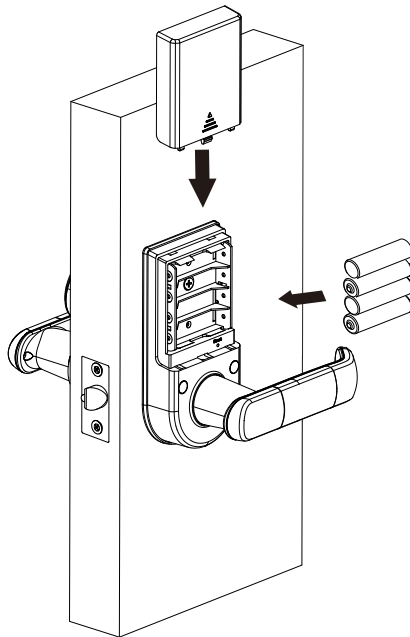

8 Installing Strike Plate and Box

- 1) Make sure that the Strike Box is aligned with the Latch bolt. Then, use the Installation Template to drill holes.
- 2) Align the Strike Plate and Box with the drilled holes and fix them with **Screw A**.

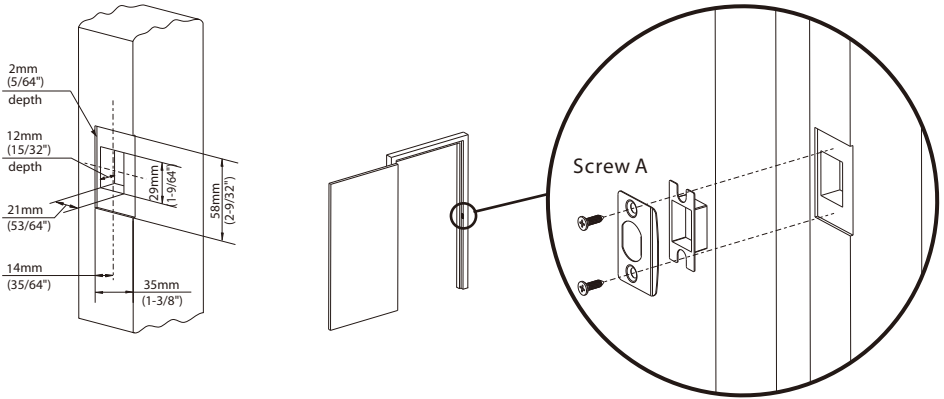

9 Physical Testing

A. Test the lock by rotating the handle.

Note: When the door is locked, the front handle can be turned, but the door will remain locked.

B. Test the lock by using the mechanical key.

Insert the Key into key hole and rotate 90°, then rotate down the handle to open the door.

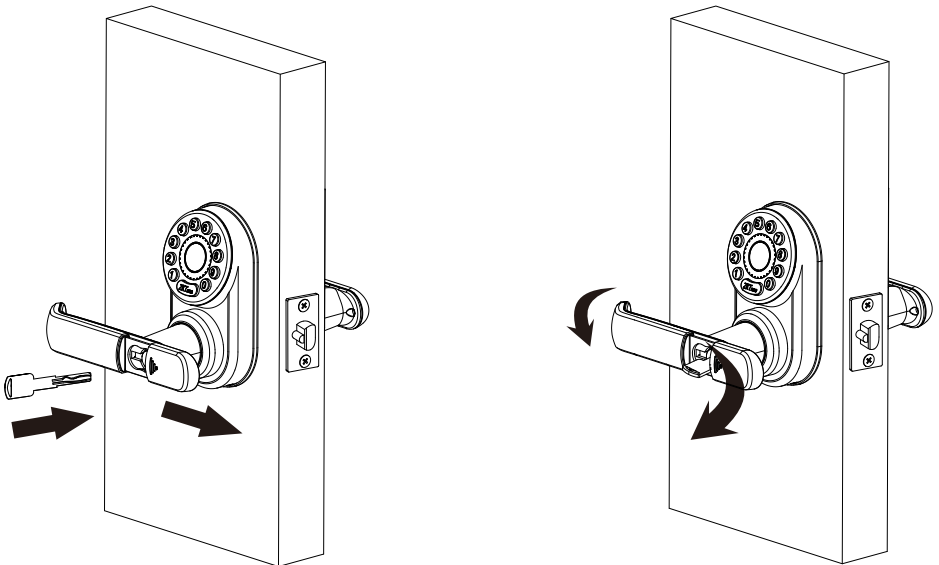

Guía de Instalación

Modelo: Series ML200/ML300

Estándar de la Cerradura: Estándar Americano

Versión: 1.1

Español

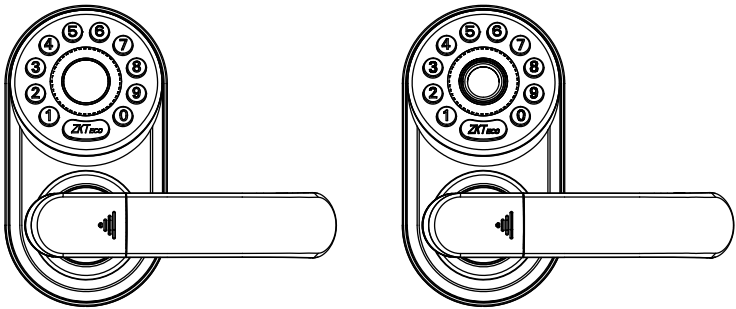

Notas Importantes

1. Lea atentamente esta guía de instalación o póngase en contacto con el servicio de atención al cliente si tiene alguna pregunta relacionada con la instalación.
2. Se recomienda que la instalación la realice un profesional para evitar cualquier cargo de servicio adicional que pueda causar debido a una instalación incorrecta del producto.
3. Revisamos constantemente el contenido de esta guía de instalación y actualizamos nuestros productos para mejorar la calidad y el rendimiento sin previo aviso.
4. No inserte las pilas antes de instalar la cerradura.

Tabla de Contenido

Contenido de la Caja.....	1
Diagrama de Instalación.....	2
Pasos de Instalación.....	2
1. Propiedades de las Puertas.....	2
2. Taladrar agujeros en la puerta	3
3. Instalar el pestillo.....	4
4. Instalación de la unidad exterior.....	5
5. Instalación de la placa de montaje y junta.....	6
6. Instalación de la unidad interior.....	6
7. Instalación de la batería y la cubierta.....	7
8. Instalación de la placa metálica y la contra chapa.....	8
9. Prueba física.....	8

Contenido de la Caja



Unidad Exterior

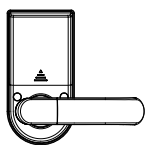

Unidad Interior

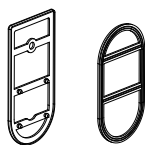

Junta



Placa de Montaje

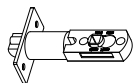

Pestillo

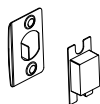

Placa Metálica y Contrachapa



Taquete

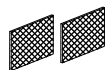

Cinta Doblecara



Llaves



Llave Hexagonal

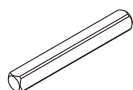

Perno



Tornillo A



Tornillo B



Tornillo C



Tornillo D



Tornillo E

Grosor de la puerta	Perno	Tornillo B	Tornillo C
30 a 37 mm	56 mm	20 mm	25 mm
38 a 45 mm	64 mm	30 mm	35 mm
46 a 53 mm	72 mm	35 mm	40 mm
54 a 60 mm	80 mm	45 mm	50 mm

Nota: Los tornillos y pernos para las puertas de espesor de **30 a 60** mm están incluidos en el paquete estándar. Utilice el juego de tornillos adecuado según el grosor de su puerta, para asegurar el correcto funcionamiento de la cerradura.

Diagrama de Instalación

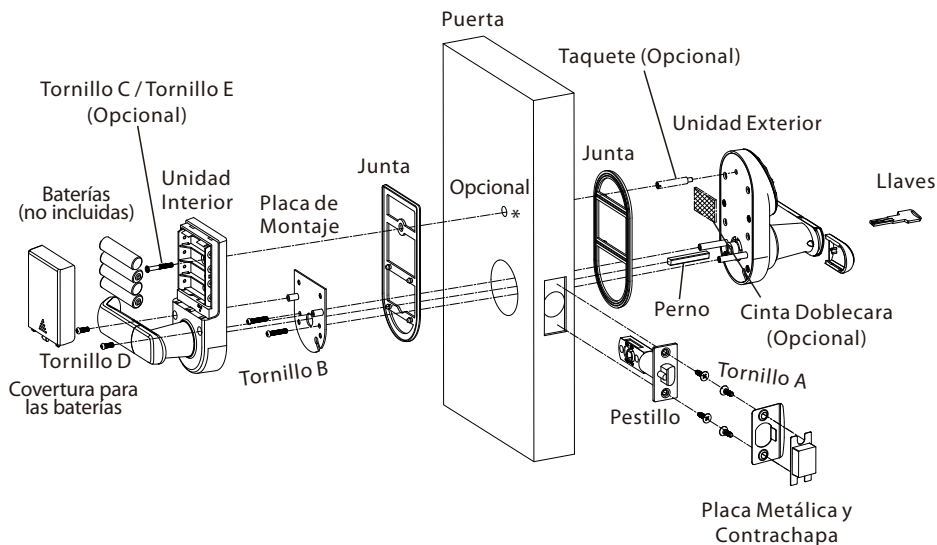

⚠ Nota Importante

Puede utilizar las cintas o taquete suministrados para estabilizar la unidad exterior. El taquete requiere perforar un orificio adicional.

Pasos de Instalación

1 Propiedades de las Puertas

A. Medidas y grosor de la puerta

Mida el grosor de la puerta y seleccione el perno y la longitud de tornillo adecuados. Para más detalles, consulte el contenido de la tabla de la página 1.

B. Verifique la dirección de apertura de la puerta

La posición de manija es determinada por la dirección de apertura de la puerta. Debajo se encuentra la representación gráfica de la apertura de la puerta, referencia a su ubicación fuera de la habitación.

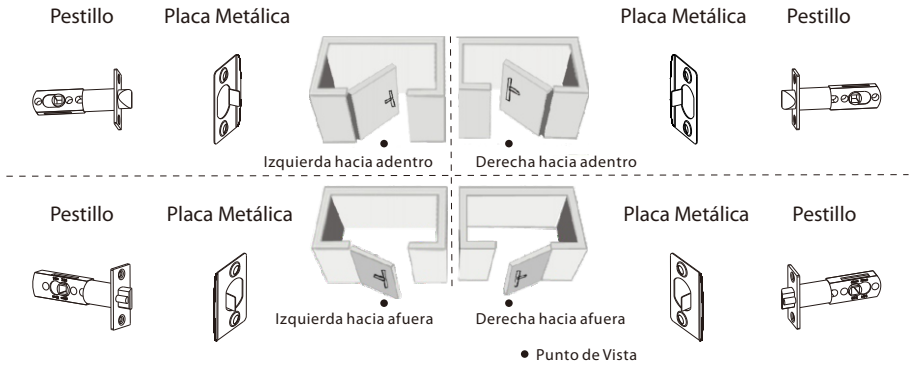

C. Cambie la dirección de la manija (si es necesario)

- 1) Use una Llave Hexagonal para quitar el tornillo de la manija. Retire la manija de la cerradura.
- 2) Cambie la dirección y vuelva a colocar la manija en su posición. De nuevo asegure la manija con el tornillo.

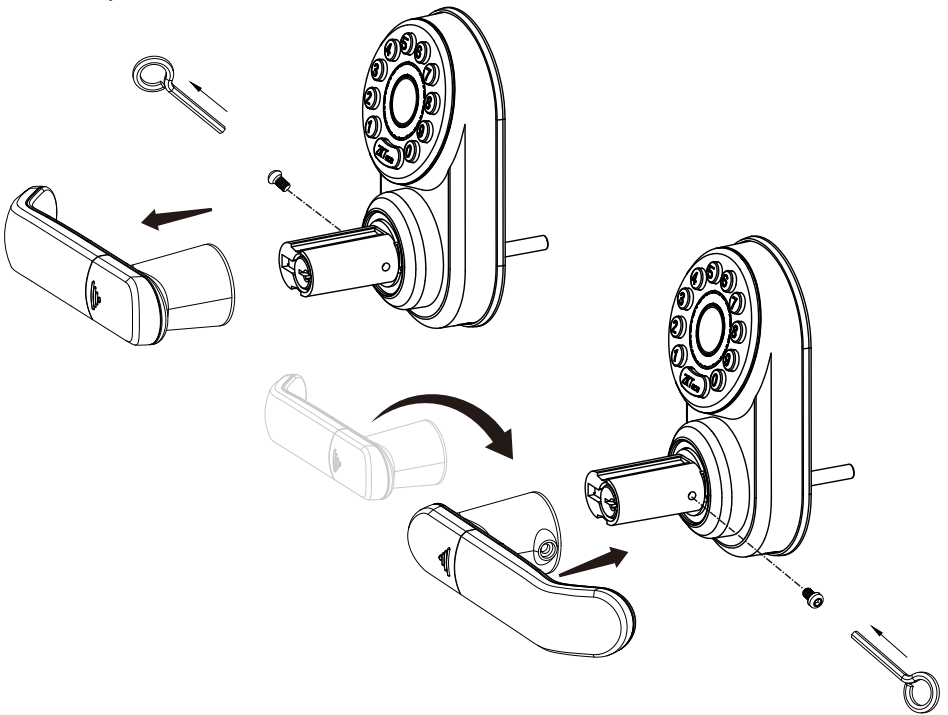

2 *Taladrar agujeros en la puerta

- 1) Coloque la plantilla de instalación a la altura deseada de la manija.
- 2) Marcar los agujeros y perforar los lugares marcados.

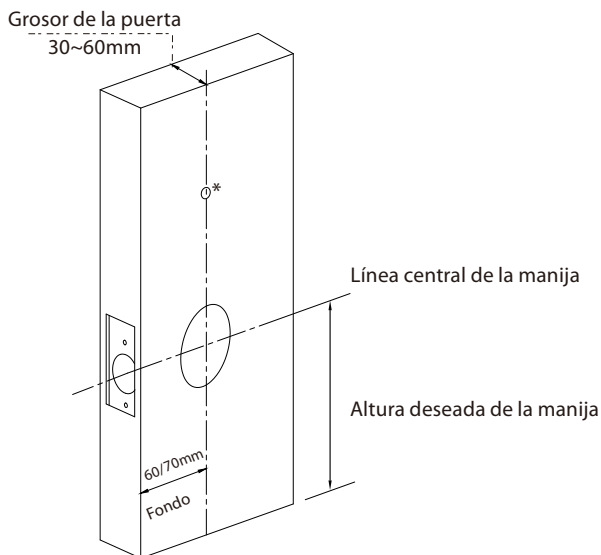

⚠ NOTA

- 1) * Si no desea perforar este orificio adicional en su puerta, puede omitir este paso.
- 2) Si desea tener mayor estabilidad, perforo el orificio consultando la plantilla de instalación proporcionada.

3 Instalar el pestillo

- 1) Ajuste el fondo de la cerradura. (si es necesario)
- 2) Asegure el pestillo con el tornillo A.

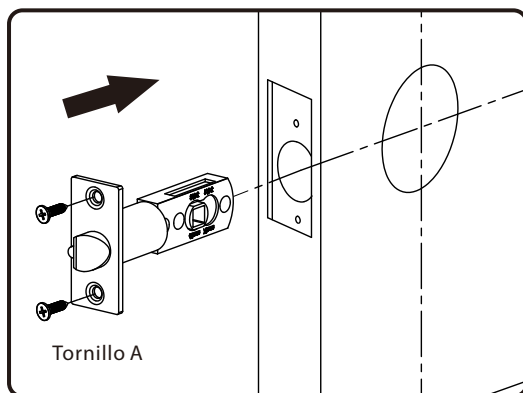
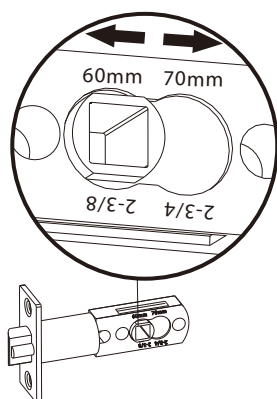

4 Instalación de la unidad exterior

Hay dos métodos para instalar la unidad exterior.

vMétodo 1: Instalación con cinta doblecara

- 1) Pegue una cinta en la placa de montaje de la unidad exterior.
- 2) Inserte el perno en el embrague. **Asegúrese de que la marca del triángulo apunte a la posición centrada verticalmente.**
- 3) Conecte la unidad exterior a la puerta insertando el cable a través de los orificios perforados.

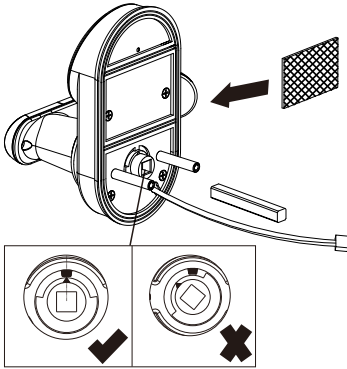

Posición correcta del embrague:
El triángulo debe estar centrado verticalmente.

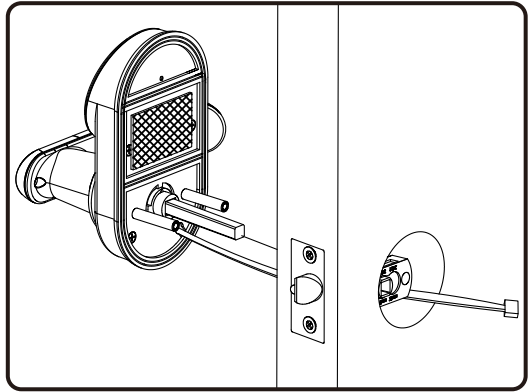

vMétodo 2: Instalación con taquete

- 1) Fije el taquete en la placa de montaje de la unidad exterior.
- 2) Inserte el eje en el embrague. **Asegúrese de que la marca del triángulo apunte a la posición centrada verticalmente.**
- 3) Conecte la unidad exterior a la puerta insertando el cable a través de los orificios perforados.

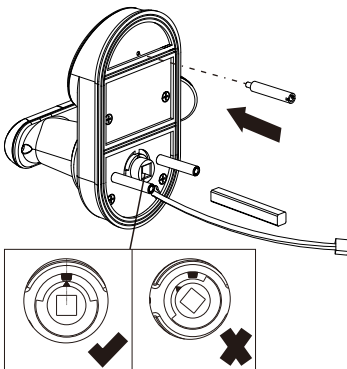

Posición correcta del embrague:
El triángulo debe estar centrado verticalmente.

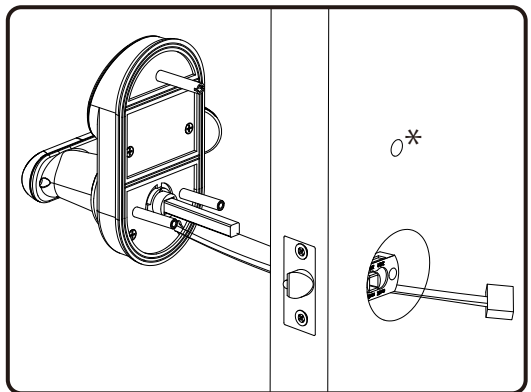

5 Instalación de la placa de montaje y junta

- 1) Fije la placa de montaje a la junta y pase el cable a través del orificio.
- 2) Coloque la junta y la placa de montaje en la puerta y use el tornillo B para asegurarlos.

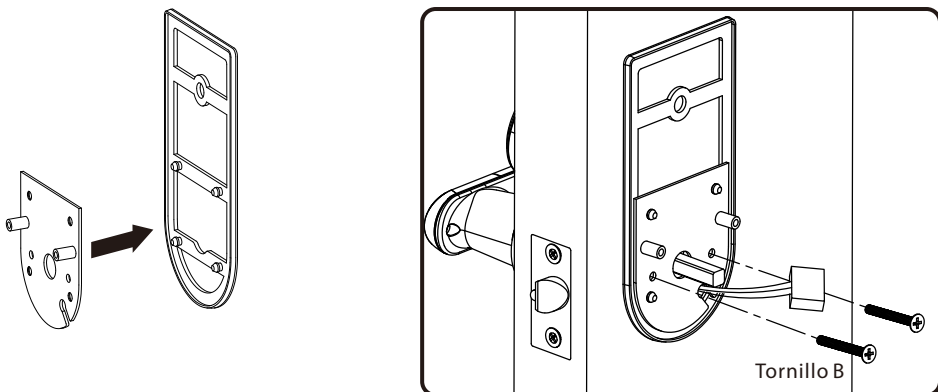

6 Instalación de la unidad interior

Seleccione el método de instalación de la unidad interior de acuerdo con el método de instalación de la unidad exterior seleccionado anteriormente en el paso 4.

vMétodo 1: Instalación con cinta doblecara

- 1) Conecte los cables al puerto de la unidad interior.
- 2) Coloque la unidad interior correctamente en la placa de montaje. Luego use el **tornillo D** y el **tornillo E** para fijar la unidad interior.

Nota: Fije el **tornillo E** en la puerta de madera con el destornillador.

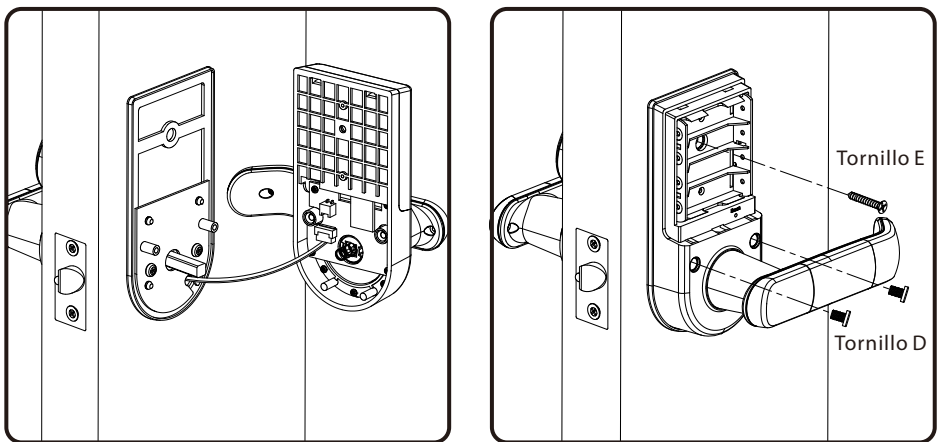

vMétodo 2: Instalación con Taquete

- 1) Conecte el cable al puerto de la unidad interior.
- 2) Coloque la unidad interior correctamente en la placa de montaje. Luego use el **tornillo C** y el **tornillo D** para fijar la unidad interior.

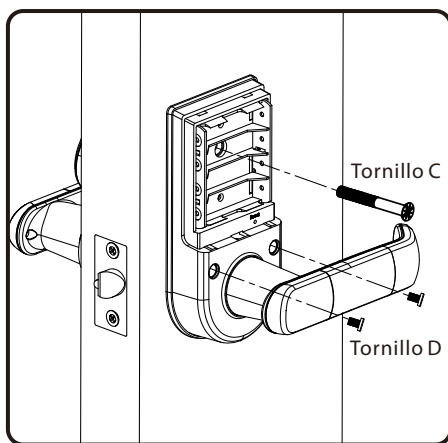
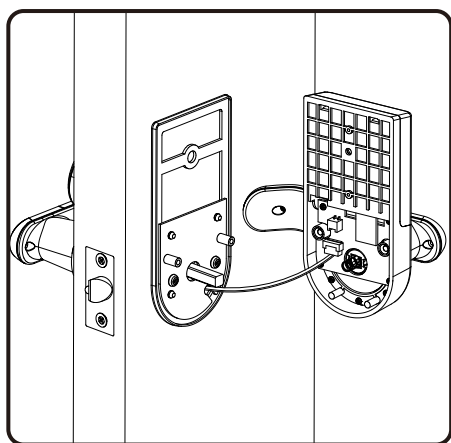

7 Instalación de la batería y la cubierta

Inserte cuatro pilas alcalinas AA y cúbralas con la tapa de la batería.

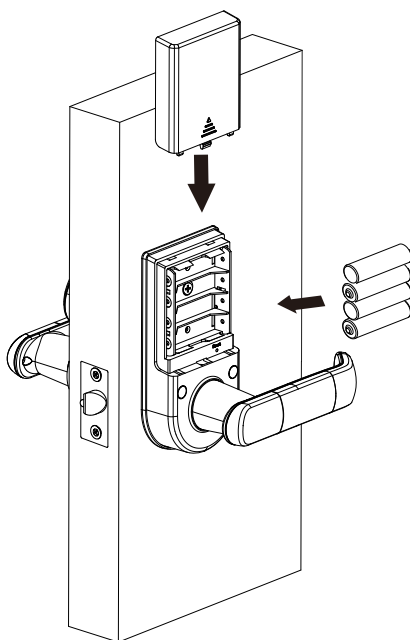

8 Instalación de la placa metálica y la contrachapa

- 1) Asegúrese de que la caja esté en el mismo nivel que el pestillo del cerrojo. Utilice la plantilla de instalación para perforar orificios.
- 2) Alinee la placa metálica y la contrachapa con los agujeros perforados y asegúrelos con el tornillo A.

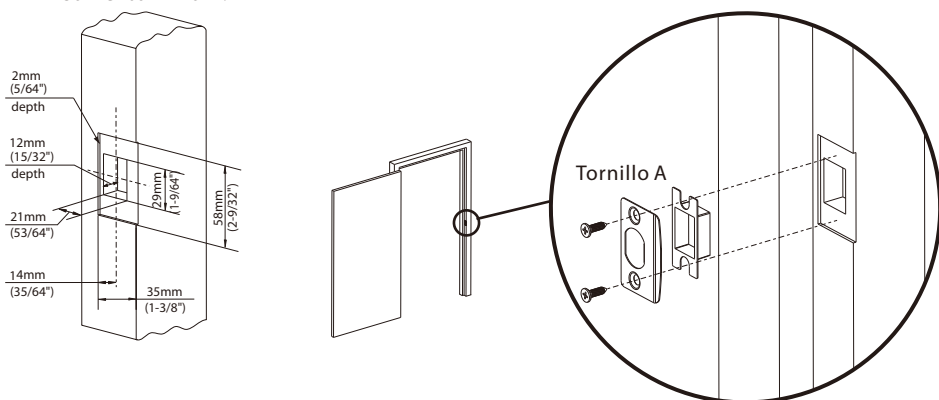

9 Prueba física

A. Pruebe la cerradura girando la manija

Nota: Cuando la puerta está cerrada, la manija delantera puede girar, pero la puerta permanece bloqueada.

B. Pruebe la cerradura usando la llave mecánica

Inserte la llave en el orificio de la llave y gire 90°, luego gire la manija hacia abajo para abrir la puerta.

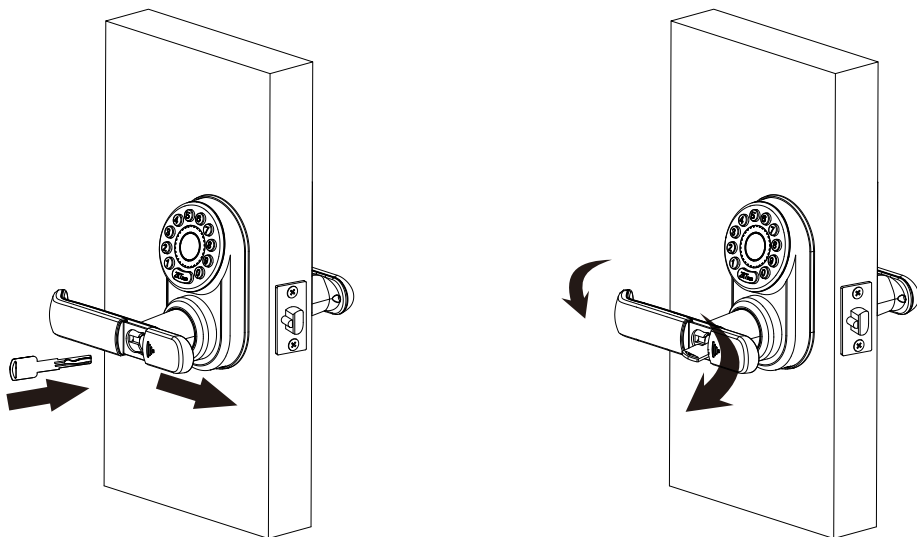

Guia de Instalação

Modelo: Série ML200/ML300

Fechadura de trava única modelo americano

Versão: 1.1

Português

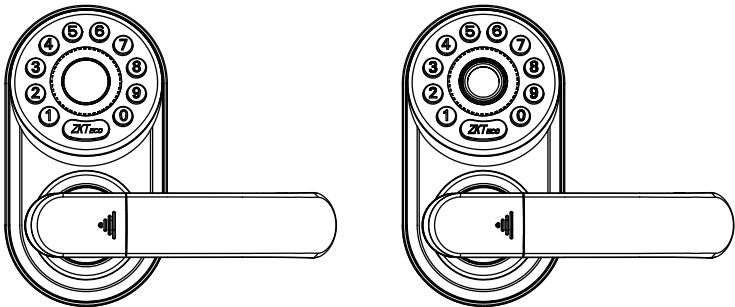

Informações importantes

1. Por favor, leia este Guia de Instalação cuidadosamente ou entre em contato com o Atendimento ao Cliente para qualquer dúvida sobre a instalação.
2. Recomenda-se que a instalação seja realizada por um profissional para evitar quaisquer encargos de serviço adicionais que podem causar devido à instalação inadequada do produto.
3. Nós revisamos constantemente o conteúdo deste Guia de Instalação e atualizamos nossos produtos para melhorar a qualidade e o desempenho sem qualquer aviso prévio.
4. Não coloque as pilhas antes de instalar a fechadura.

Índice

O que tem na caixa.....	1
Diagrama de instalação.....	2
Procedimento de instalação.....	2
1. Propriedades da porta.....	2
2. *Fazendo os furos na porta.....	3
3. Instalando a trava.....	4
4. Instalando Unidade Externa.....	5
5. Instalação da placa de montagem e borracha.....	6
6. Instalação da unidade interna.....	6
7. Instalação das pilhas e tampa traseira da bateria.....	7
8. Instalando a o batente e a caixa.....	8
9. Testes funcionais.....	8

O que tem na caixa



Unidade externa

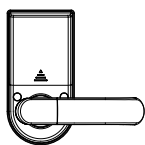

Unidade interna

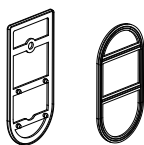

Borrachas



Placa montagem

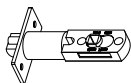

Trava

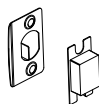

Batenete e caixa



Pino

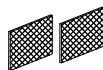

Fita



Chave



Chave Hex



Chaveta



Parafuso A



Parafuso B



Parafuso C



Parafuso D



Parafuso E

Espessura da porta	Chaveta	Parafuso B	Parafuso C
30 a 37 mm	56 mm	20 mm	25 mm
38 a 45 mm	64 mm	30 mm	35 mm
46 a 53 mm	72 mm	35 mm	40 mm
54 a 60 mm	80 mm	45 mm	50 mm

Nota: Parafusos e chavetas para portas de espessura de **30 a 60** mm estão incluídos no pacote padrão. Use o conjunto apropriado de parafusos de acordo com a espessura da porta, para garantir o funcionamento adequado da fechadura.

Diagrama de instalação

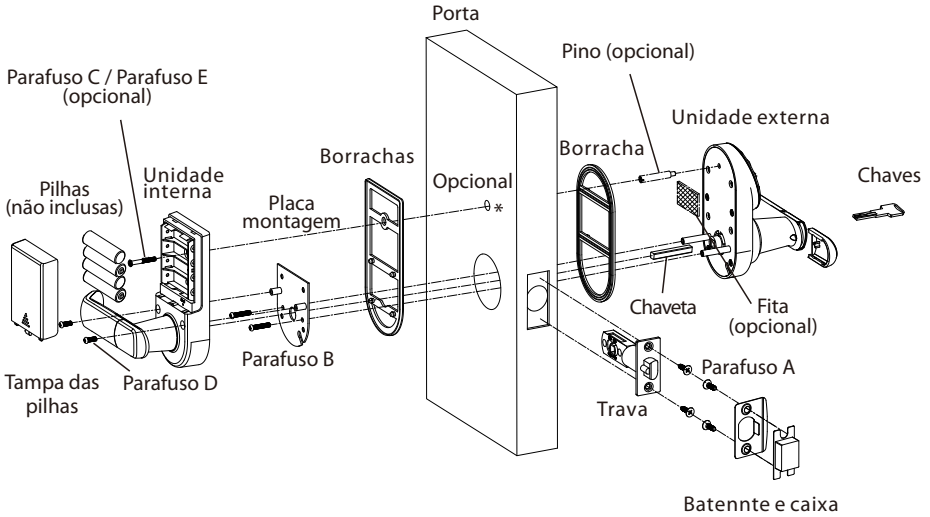

⚠ Importante

Você pode usar as fitas fornecidas ou pino para estabilizar a unidade externa. O pino requer a perfuração de um furo extra.

Procedimento de instalação

1 Propriedades da porta

A. Meça a espessura da porta

Meça a espessura da porta e selecione o comprimento adequado do eixo e do parafuso. Para obter detalhes, consulte o conteúdo da tabela da Página 1.

B. Verifique a direção de abertura da porta

A posição da maçaneta é determinada pela direção de abertura da porta. Abaixo está a representação gráfica da direção de abertura da porta em referência à sua localização fora da sala.

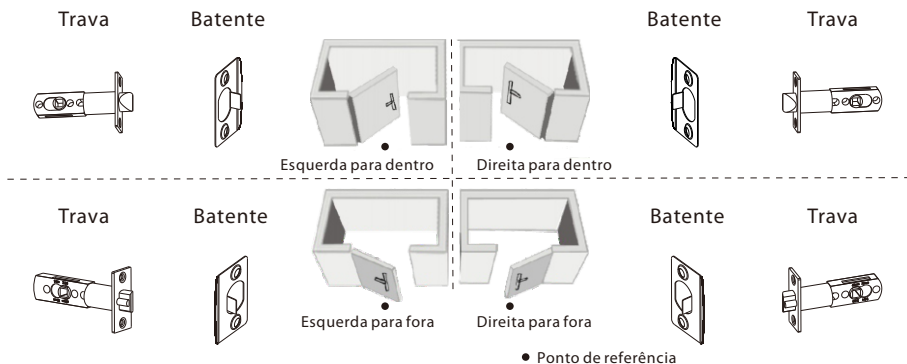

C. Mude a direção da maçaneta (se necessário)

- 1) Use a chave hexagonal para remover o parafuso da maçaneta e a remova.
- 2) Mude a direção da maçaneta, coloque-a novamente e fixe-a usando o parafuso.

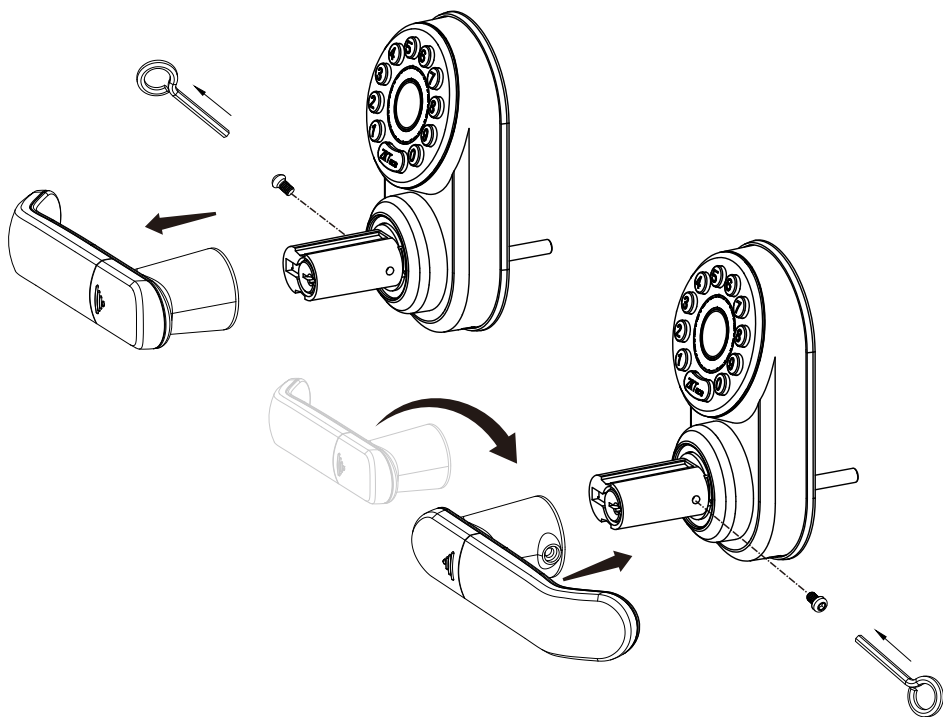

2 *Fazendo os furos na porta

- 1) Coloque o gabarito de instalação na altura desejada da maçaneta.
- 2) Marque os furos a serem feitos e os faça nos locais marcados.

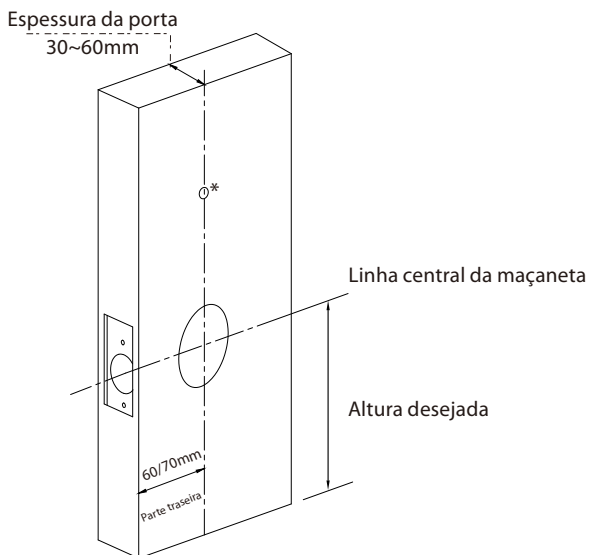

NOTA

- 1) * Se você não quiser fazer um furo extra em sua porta, pule esta etapa.
- 2) Se você deseja ter estabilidade adicional, faça o furo consultando o gabarito de instalação fornecido.

3 Instalando a trava

- 1) Ajuste o "backset" da fechadura. (se necessário)
- 2) Fixe a trava com o parafuso A. Certifique-se de que o ângulo da trava esteja voltado para o batente da porta.

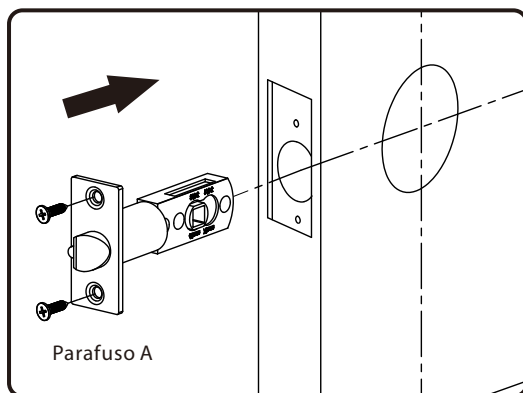
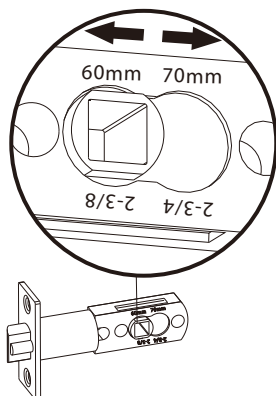

4 Instalando Unidade Externa

Existem dois métodos para instalar a unidade externa.

vMétodo 1: Instalando com fitas dupla face

- 1) Cole uma fita dupla face na placa de montagem da unidade externa.
- 2) Insira o eixo na embreagem. **Certifique-se de que a marca do triângulo aponta para a posição centralizada verticalmente.**
- 3) Conecte a unidade externa à porta inserindo o cabo através dos furos.

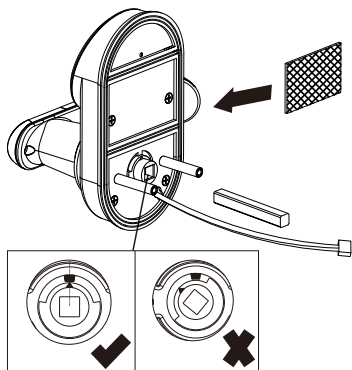

Nota: O triângulo deve estar centrado verticalmente.

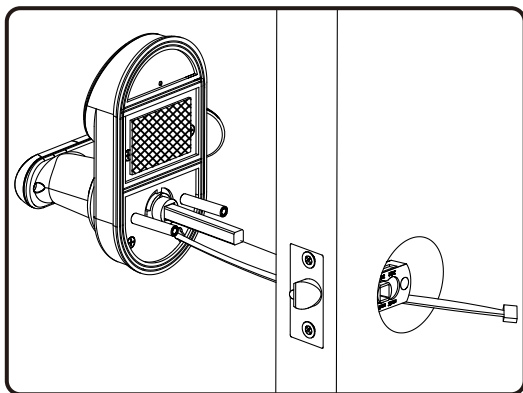

vMétodo 2: instalação com pino

- 1) Fixe o pino na placa de montagem da unidade externa.
- 2) Insira o eixo na embreagem. **Certifique-se de que a marca do triângulo aponta para a posição centralizada verticalmente.**
- 3) Conecte a unidade externa à porta inserindo o cabo através dos furos.

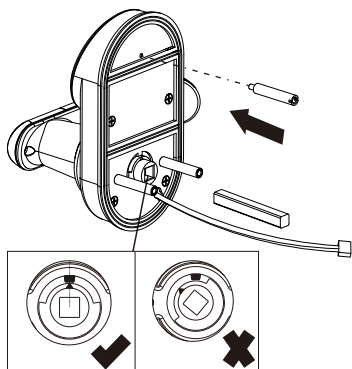

Nota: O triângulo deve estar centrado verticalmente.

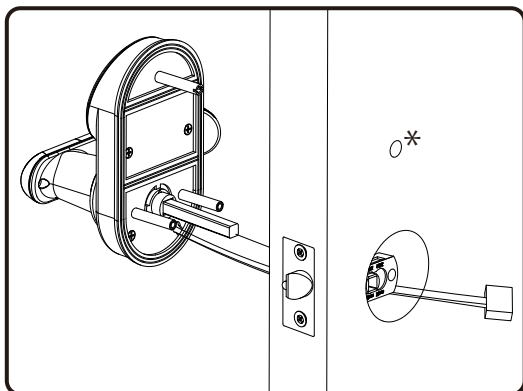

5 Instalação da placa de montagem e borracha

- 1) Fixe a placa de montagem à borracha e direcione o cabo através do furo.
- 2) Coloque a borracha e a placa de montagem na porta e use o parafuso B para fixá-las.

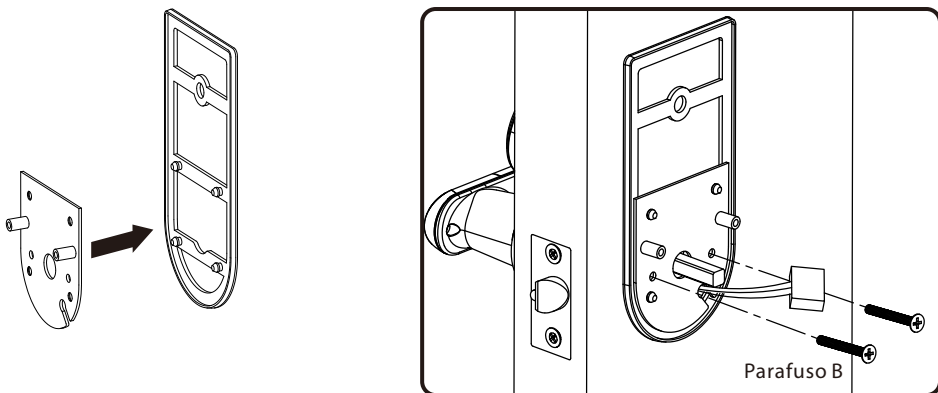

6 Instalação da unidade interna

Selecione o método de instalação da unidade interna de acordo com o previamente selecionado na etapa 4 **Método de instalação de unidade externa**.

vMétodo 1: Instalando com fitas dupla face

- 1) Conecte os cabos à porta na unidade interna.
- 2) Coloque a unidade interna corretamente na placa de montagem. Em seguida, use o **parafuso D** e **parafuso E** para fixar a unidade interna.

Nota: Fixe o **parafuso E** na porta de madeira com a chave de fenda.

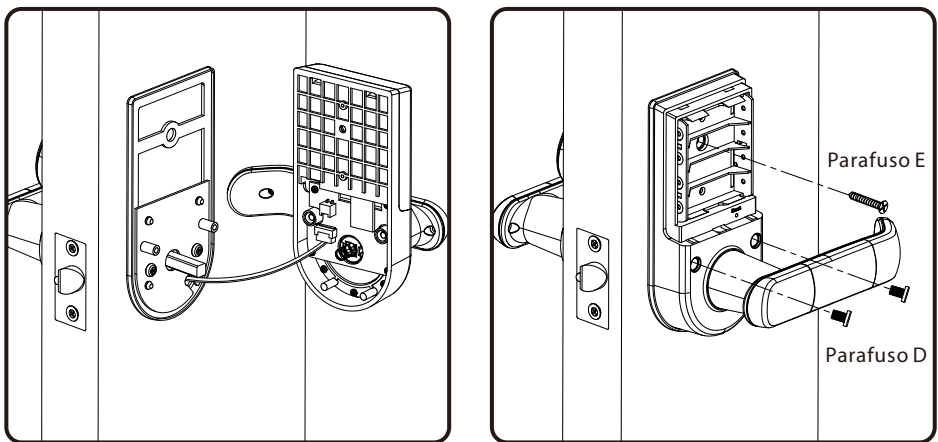

vMétodo 2: Instalação com pino

- 1) Conecte o cabo à porta na unidade interna.
- 2) Coloque a unidade interna corretamente na placa de montagem. Em seguida, use o **parafuso C** e o **parafuso D** para fixar a unidade interna.

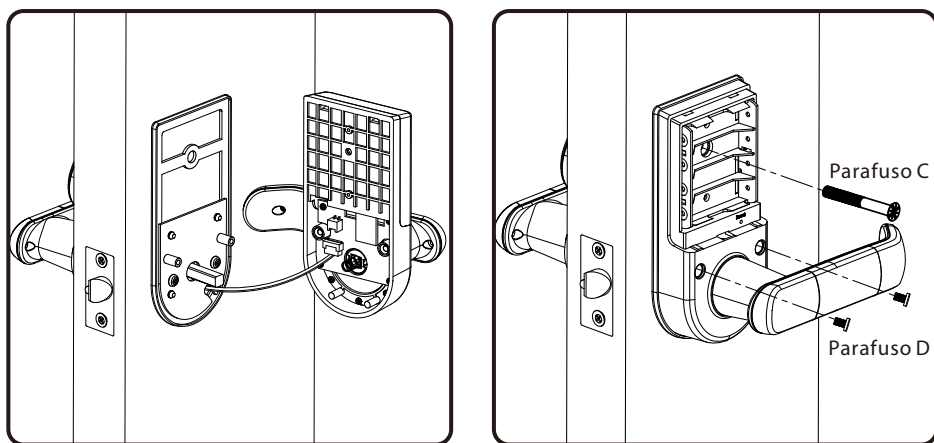

7 Instalação das pilhas e tampa traseira da bateria

Coloque quatro **pilhas AA alcalinas** e feche-as com uma tampa traseira de bateria.

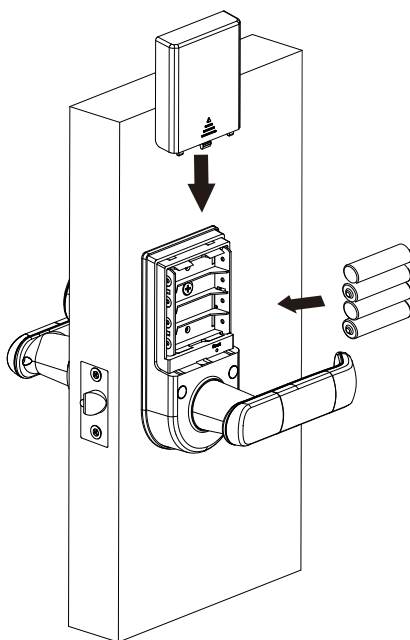

8 Instalando a o batente e a caixa

- 1) Certifique-se de que a caixa está alinhada com o parafuso da trava. Em seguida, use o gabarito de instalação para fazer furos.
- 2) Alinhe a o batente e a caixa com os furos e fixe-os com o parafuso A.

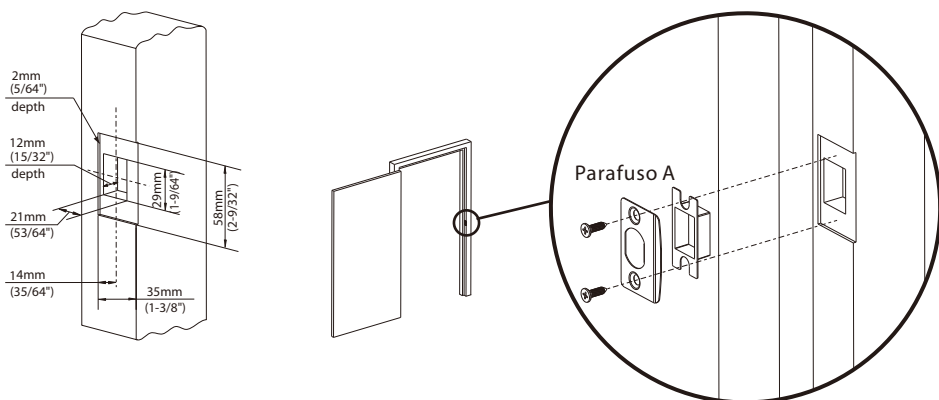

9 Testes funcionais

A. Teste a fechadura girando a alça.

Nota: Quando a porta está trancada, a maçaneta frontal pode ser girada, mas a porta permanecerá trancada.

B. Teste a fechadura usando a chave mecânica.

Insira a chave no orifício da fechadura e gire 90°, depois gire para baixo a maçaneta para abrir a porta.

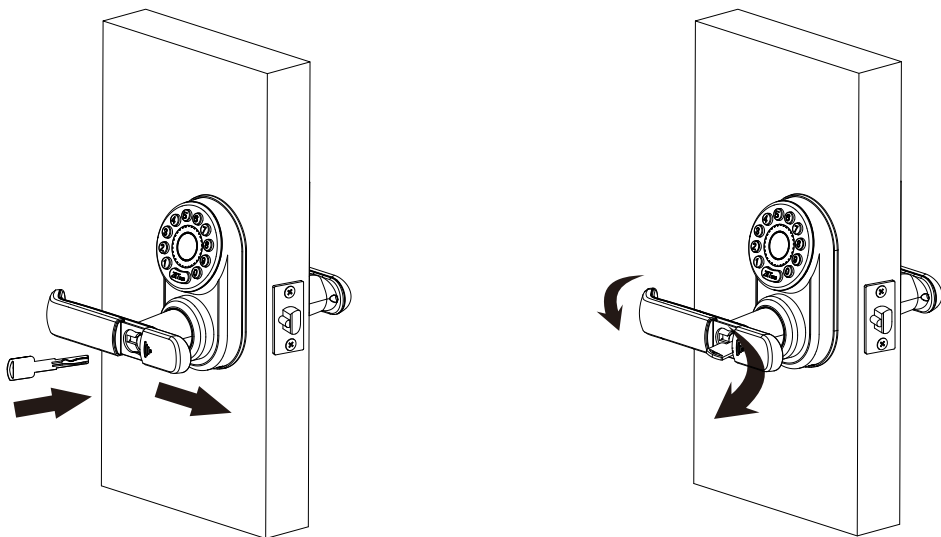



Warning:

This device complies with Part 15 of the FCC Rules. Operation is subject to the following two conditions: (1) This device may not cause harmful interference, and (2) this device must accept any interference received, including interference that may cause undesired operation.

This equipment has been tested and found to comply with the limits for a Class B digital device, pursuant to Part 15 of the FCC Rules. These limits are designed to provide reasonable protection against harmful interference in a residential installation. This equipment generates, uses, and can radiate radio frequency energy and, if not installed and used in accordance with the instructions, may cause harmful interference to radio communications. However, there is no guarantee that interference will not occur in a particular installation. If this equipment does cause harmful interference to radio or television reception, which can be determined by turning the equipment off and on, the user is encouraged to try to correct the interference by one or more of the following measures:

- Reorient or relocate the receiving antenna.
- Increase the separation between the equipment and receiver.
- Connect the equipment into an outlet on a circuit different from that to which the receiver is connected.
- Consult the dealer or an experienced radio/TV technician for help.

FCC RF Radiation Exposure Statement:

- This Transmitter must not be co-located or operating in conjunction with any other antenna or transmitter.
- This equipment complies with RF radiation exposure limits set forth for an uncontrolled environment.

IMPORTANT! Any changes or modifications not expressly approved by the party responsible for compliance could void the user's authority to operate the equipment.

ZKTeco Industrial Park, No. 32, Industrial Road,

Tangxia Town, Dongguan, China.

Phone : +86 769 - 82109991

Fax : +86 755 - 89602394

www.zkteco.com

