

**VORNADO**<sup>®</sup>

ENERGY  
  
SMART

we expect  
this product  
to be **PERFECT**

Esperamos que este producto sea perfecto  
Si no lo es, ayúdenos a corregirlo

---

Nous exigeons de nos produits qu'ils soient parfaits  
Si celui-ci ne l'est pas, nous corrigerons la situation

if it's not,  
**WE** will make  
it right

vornado.com

800-234-0604

help@vornado.com

## MODELS 5303DC, 6303DC, 6803DC OWNER'S GUIDE

GUÍA DEL PROPIETARIO DE MODELOS 5303DC, 6303DC, 6803DC

GUIDE D'UTILISATION – MODÈLES 5303DC, 6303DC, 6803DC

# CONTENTS

Important Instructions .....	2
Getting Started .....	6
Features .....	8
Controls.....	9
How To Use .....	11
Remote Control.....	12
Grille & Blade Removal .....	13
Cleaning .....	14
Troubleshooting .....	15

Español p. 16    Français p. 32



5303DC

6303DC

6803DC

# READ AND SAVE THESE INSTRUCTIONS

## IMPORTANT SAFETY INSTRUCTIONS

This owner's guide and any additional inserts are considered part of the product. They contain important information about safety, use and disposal. Before using the product, please familiarize yourself with all operating and safety instructions. Please keep all documents for future reference and pass these documents on, together with the product, to any future owner. See [www.vornado.com/circulators-manuals](http://www.vornado.com/circulators-manuals) to view, download and print the most current version of these instructions.

**INTENDED USE:** This product is intended to circulate the air in indoor living spaces only in the United States and Canada. This product is not intended for commercial or industrial use. The manufacturer assumes no responsibility for damage or injury due to unauthorized use or product modification. Failure to follow these directions will void the product warranty.

### **WARNING: Risk to Children and Impaired Persons**

Supervision is required during the installation, operation, cleaning and maintenance of this product by children 12 years of age and younger and anyone with reduced physical, sensory or mental capabilities. Children should be supervised to ensure that they do not play with the appliance, its parts and packaging material.



**WARNING: Chemical burn hazard. Keep batteries away from children.**

**WARNING: KEEP NEW AND USED BATTERIES AWAY FROM CHILDREN.** This product contains a lithium button/coin cell battery. If a new or used lithium button/coin cell battery is swallowed or enters the body, it can cause severe internal burns and can lead to death in as little as 2 hours. Always completely secure the battery compartment. If the battery compartment does not close securely, stop using the product, remove the batteries, and keep it away from children. If you think batteries might have been swallowed or placed inside any part of the body, seek immediate medical attention. In the US call the National Poison Control Center at 1-800-222-1222 or 202-625-3333. In Canada call 416-813-5900.

### **INSTALLATION WARNING—To reduce risk of fire, electrical shock and injury to persons, observe the following:**

- Place this product away from curtains, draperies, tablecloths and other fabrics, since they may be drawn into the product, damage the motor and/or cause a fire.
- No part of this product (the appliance, power cord, plug, packaging, etc.) should be placed near furnaces, fireplaces, stoves or other high temperature heat sources. Do not use this product in a window, on an uneven or unstable surface, or near water.
- The appliance, power supply, power cord and plug cannot come into contact with water. Do not use this product on wet surfaces. Do not use this product in a bathtub or shower or position product where it may fall into a bathtub, laundry, swimming pool or other water container. Do not use this product outdoors or expose it to weather or elements.
- Do not run cord under carpeting. Do not cover cord with throw rugs, runners, or similar coverings. Do not route cord under

furniture or appliances. Arrange cord away from traffic area and where it will not be tripped over. The cord should not hang over edges of counters or be placed where it can be crimped or closed in doors. Place appliance near an easily accessible outlet so the product can be unplugged quickly during an emergency.

**SAFE USE WARNING—To reduce risk of fire, electrical shock and injury to persons, observe the following:**

- **WARNING:** To reduce likelihood of circuit overload, fire and electric shock, do not operate with a solid state speed device, such as a dimmer control switch.
- Do not operate any fan with a damaged cord or plug. Discard fan or return to an authorized service facility for examination and/or repair.
- Do not operate unit if the unit has been dropped or damaged. Do not use this product if it has a damaged power cord or plug. To avoid risk of electrical shock, do not attempt to repair or replace parts. Only original replacement parts may be used. If the power cord is damaged, it must be replaced by the manufacturer, its service agent, or similarly qualified persons in order to avoid a hazard. Contact Vornado Consumer Service at 1-800-234-0604 (phone) or consumerservice@vornado.com (email) for further instructions about replacement and repair.
- Risk of fire. Your appliance may be equipped with a detachable power supply or a cord/plug with a safety device such as a fuse. Use only the power cord and plug provided. The detachable external power supply and cord have no user replaceable parts.
- Before plugging power cord into electrical outlet, be sure that all electrical information on the rating label, including voltage, is compatible with your outlet's power supply.
- Do not sit or stand on product.

- Never use the cord as a handle or otherwise yank, strain or stretch the power cord.
- While the product is plugged in, do not insert or allow foreign objects to enter any input or output opening as this may cause risk of electric shock or fire, or damage the product.
- A loose fit between wall outlet (receptacle) and plug may cause overheating and distortion of the plug. Discontinue use of the product in this outlet. Contact a qualified electrician to replace loose or worn outlets.
- This appliance (models 5303DC, 6303DC only) has a polarized plug (one blade is wider than the other). To reduce the risk of electric shock, this plug is intended to fit in a polarized outlet only one way. If the plug does not fit fully in the outlet, reverse the plug. If it still does not fit, contact a qualified electrician. Do not attempt to defeat this safety feature.
- Before moving, repositioning, servicing, cleaning and when not in use, use the product controls to turn off the power and then unplug. To disconnect from outlet, grasp and pull only the plug. Also, power off and unplug if the product will be left unattended for an extended period of time or during electrical storms.

**SERVICING WARNING—To reduce risk of fire, electrical shock and injury to persons, observe the following:**

- Clean your product regularly, only as is instructed in this manual. Prior to cleaning, turn off the power on your product and unplug. Do not use gasoline, thinners, solvents, ammonias or other chemicals for cleaning. Refer to the CLEANING instructions provided.
- Do not open appliance housing while product is plugged in. To avoid risk of shock, all service and/or repairs must be done by a Vornado Authorized Service Center.
- This product (models 5303DC, 6303DC only) employs overload

protection (fuse). A blown fuse indicates an overload or short-circuit situation. If the fuse blows, unplug the product from the outlet. Replace the fuse as per the user servicing instructions (follow product marking for proper fuse rating) and check the product. If the replacement fuse blows, a short-circuit may be present and the product should be discarded or returned to an authorized service facility for examination and/or repair.

### User Servicing Instructions

1. Using the product controls, turn off the appliance.
2. Grasp the plug (not the cord) and disconnect from the outlet.
3. Risk of Fire. Replace fuse only with 2.5 Amp, 125 Volt fuse as approved by Vornado Consumer Service. For an authorized replacement fuse, please contact Vornado Consumer Service.
4. Once the replacement is received, use a small flat-head screwdriver to slide open the fuse cover (located on the plug) (See Fig. A).
5. Remove fuse by using the screwdriver to gently lift each end of the fuse (See Fig. B).
6. Install the replacement fuse by using the screwdriver to gently push each metal end of the fuse into the receptacle one at a time. Do not push on the center of the fuse—it is fragile and may break.
7. Slide the fuse cover closed using the screwdriver. When closed, the cover should fit completely in the plug. No part of the cover should stick out (See Fig. C).
8. Plug your appliance into the outlet and turn the power on.
9. If the replacement fuse blows, a short-circuit may be present and the product should be discarded or returned to an authorized service facility for examination and/or repair.

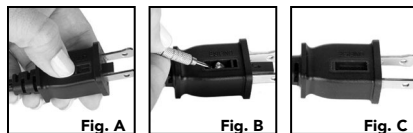

Risk of fire. Do not replace attachment plug. Contains a safety device (fuse, AFCI, LCDI) that should not be removed. Discard product if the attachment plug is damaged.

### FCC Compliance Statement

**NOTE:** This equipment has been tested and complies with Part 15 of the FCC Rules. Operation is subject to the following two conditions: (1) This device may not cause harmful interference, and (2) this device must accept any interference received, including interference that may cause undesired operation.

This equipment has been tested and found to comply with the limits for a Class B digital device, pursuant to Part 15 of the FCC Rules. These limits are designed to provide reasonable protection against harmful interference in a residential installation. This product generates, uses and can radiate radio frequency energy and, if not installed and used in accordance with the instructions, may cause harmful interference to radio communications.

However, there is no guarantee that interference will not occur in a particular installation. If this product does cause harmful interference to radio or television reception, which can be determined by turning the product off and on, the user is encouraged to try to correct the interference by one or more of the following measures:

- Reorient or relocate the receiving antenna.
- Increase the separation between the product and the receiver.

- Connect the product into an outlet on a circuit different from that to which the receiver is connected.
- Contact Vornado Consumer Service or dealer or an experienced radio/TV technician for help.

This Class B digital apparatus complies with Canadian ICES-003.

Changes or modifications to this unit not expressly approved by the party responsible for compliance could void the user's authority to operate the product.

### **Supplier's FCC Declaration of Conformity**

Unique Identifier: Vornado Models 5303DC, 6303DC, 6803DC

Responsible Party: Vornado Air LLC

Mailing Address : 415 E. 13th St., Andover, KS 67002

Contact: [www.vornado.com](http://www.vornado.com)

**WARNING: Batteries may pose a choking hazard. Do not let children handle batteries.**

**BATTERY DISPOSAL:** Please dispose of batteries according to the local laws and regulations of your region, and while keeping them away from children. Some batteries may be recycled and accepted for disposal at your local recycling center. **DO NOT DISPOSE OF BATTERIES IN FIRE. BATTERIES MAY EXPLODE OR LEAK.** New and used batteries may cause injury. Keep new and used cells (or batteries) away from children.

## **SAVE THESE INSTRUCTIONS**

# GETTING STARTED

## Installing Circulator Head (Model 6803DC Only)

*No tools required!*

1. Gently place the circulator head face down on the ground on a soft cloth to avoid scratches or damages to the unit. Insert power cord into the top of pole (A) and pull through the bottom (B). Align the Lock Release Button (C) on circulator head with the hole (D) located on the pole. Push the pole onto the circulator head until the Lock Release Button snaps into place.

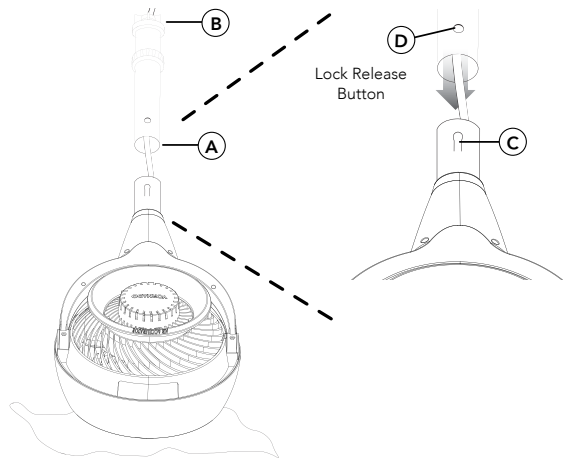

## Stand Assembly (Model 6803DC Only)

1. The upper pole and lower pole are pre-assembled, with the fastening nut (E) secured on the underside of the base. Rotate fastening nut counter-clockwise to remove.
2. The legs are designed to fit into the grooves (F) on the underside of the base cap. Assemble all the legs onto the pole, then replace fastening nut by rotating clockwise to secure all the legs in place.

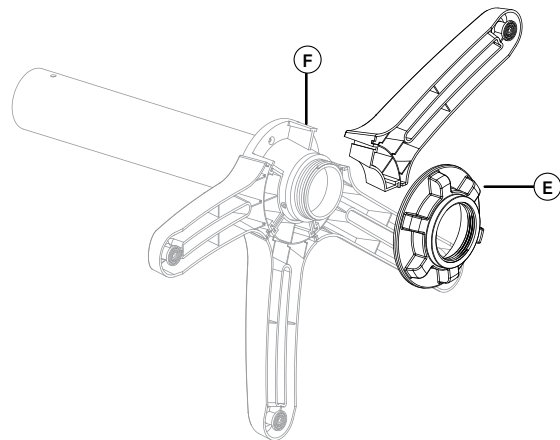



# GETTING STARTED

(Continued)

## Cord Management (Models 5303DC, 6303DC Only)

1. Wrap cord around Air Accelerator, located on back of unit. Secure cord with three clips (G) located at 2, 6 and 10 o'clock positions.

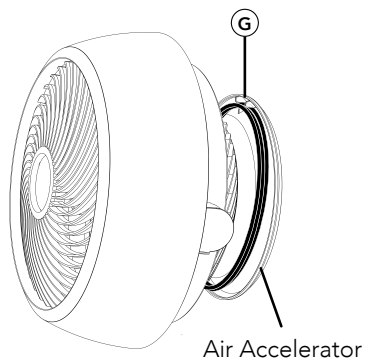

## Adjusting Height (Model 6803DC Only)

1. Before adjusting the height of the circulator, support the circulator head with one hand. Use your other hand to loosen the height adjustment collar by gently rotating it counter-clockwise.
2. Slowly raise or lower the pole to the desired height and secure into position by rotating the adjustment collar clockwise until tight.

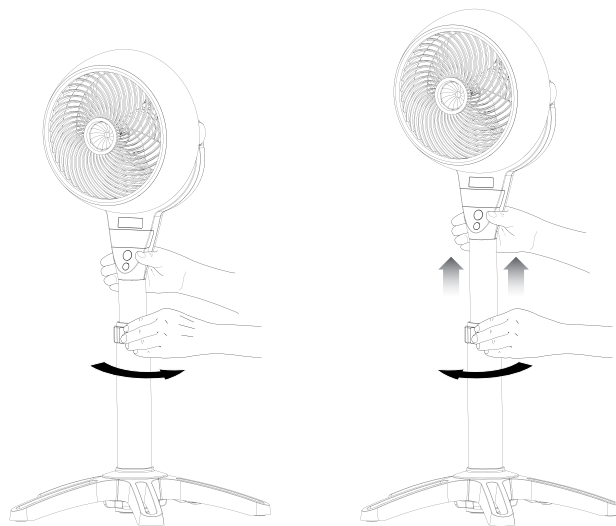

# FEATURES

## DIRECTABLE AIRFLOW

Direct the airflow where you want it.

## ENERGY-SAVING TIMER

1–12 hour timer.

## TOUCH-SENSITIVE CONTROLS (99 SPEEDS)

A speed setting for every comfort level.

## REMOTE CONTROL

Convenience at your fingertips.

## CORD MANAGEMENT

Integrated cord wrap.

## FINGER FRIENDLY DESIGN

Resists curious fingers.

## SILICON FEET

Non-marking feet added for stability.



# CONTROLS

Models 5303DC, 6303DC Only



TIMER BUTTON 

POWER ON/OFF 

SPEED/TIMER  
INDICATOR DISPLAY

SPEED/TIMER  
ADJUSTMENT BUTTONS -/+



# CONTROLS

Model 6803DC Only

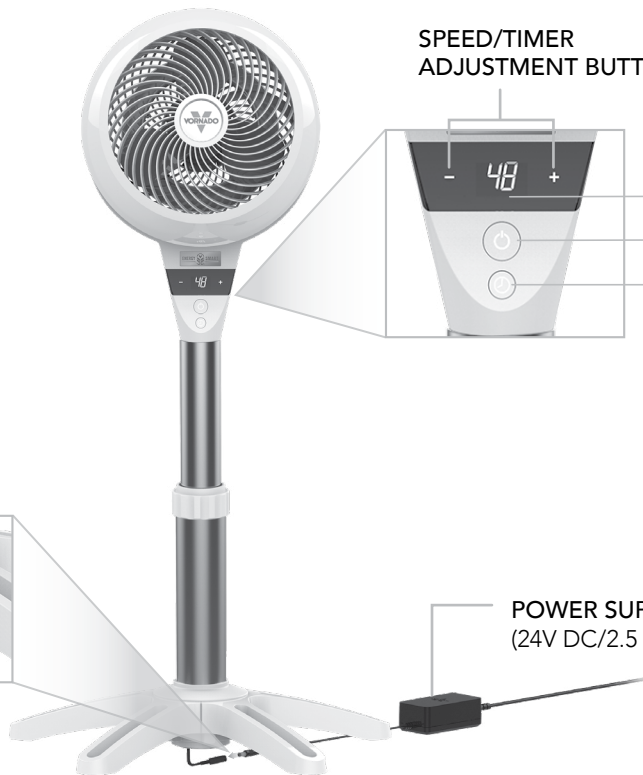
1. Insert DC power cord plug into port that extends from the bottom of circulator.
2. Connect the AC power cord to the power supply.
3. Plug the power cord into a power outlet.



SPEED/TIMER  
ADJUSTMENT BUTTONS -/+

SPEED/TIMER  
INDICATOR DISPLAY  
POWER ON/OFF   
TIMER BUTTON 

POWER SUPPLY  
(24V DC/2.5 AMP)



**Note:** The external power supply may become slightly warm to the touch during normal operation.

# HOW TO USE

1. Touch  to power on.



Your circulator returns to last saved memory setting.

2. Select desired speed by pressing **-/+**. Press and hold **-/+** to adjust speed up or down in 5 speed increments. Speed is indicated by number shown on Speed/Timer Indicator Display.
3. Press  to activate timer. The  illuminates and Speed/Timer Indicator Display flashes **0** to indicate Timer Adjustment Mode. While in this mode, select amount of time in one-hour intervals by pressing **-/+**. After three seconds, flashing stops and display shows hours to indicate timer is set. The display returns to the last speed selected. Touch  to quickly tell how many hours are remaining on the timer.



4. To adjust timer, repeat Step Three.
5. To cancel timer, repeat Step Three and set timer for **0**.

## CORD MANAGEMENT

1. Wrap cord around Air Accelerator, located on back of unit. Secure cord with three clips located at 2, 6 and 10 o'clock positions.

# REMOTE CONTROL

Screwdriver required. 

Your circulator remote includes (1) coin style 3V CR2032 battery. Battery comes pre-installed. Remove battery pull tab before first use.

1. For battery replacement, the remote requires one coin style 3V CR2032 battery. Always use the correct size and grade of battery for this product.
2. To replace battery, open battery door on the back side of the remote control (you will need to loosen the small screw on door using a #1 Phillips screwdriver). If necessary, clean the battery contacts and also those of the device prior to battery installation. Remove any plastic protection from the battery and place it in the remote with the + side facing out. Ensure the battery is installed correctly with regard to polarity. Replace the battery door and screw.

**Note:** Remove battery from the remote control when not in use for an extended period of time and always remove dead battery immediately and replace with fresh. Do not store dead battery in remote.

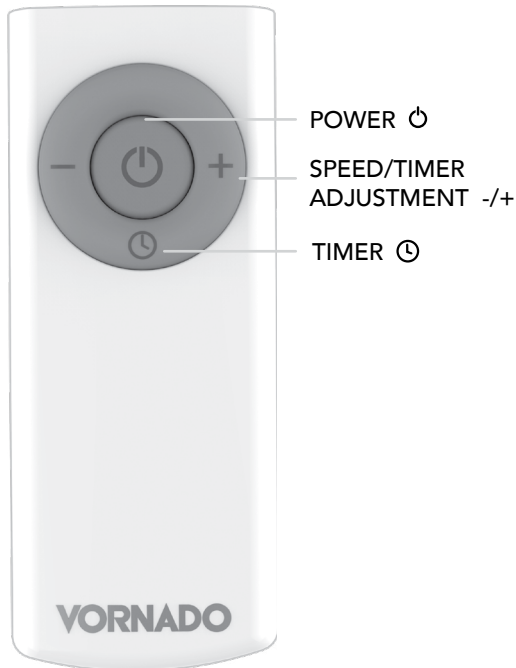

The remote control functions are the same as the control panel on the circulator.

The remote requires a line-of-sight path to allow for the signal to be received by the circulator. Point the remote control at the display panel for best reception.

 **WARNING:** This product contains a button battery. If swallowed, it could cause severe injury or death in just 2 hours. Seek medical attention immediately.

# GRILLE & BLADE REMOVAL

Screwdriver required. 

 **WARNING:** To reduce the risk of electrical shock and injury to persons, unplug the circulator before removing grille or blade.

## REMOVABLE GRILLE

1. Using a phillips head screwdriver, remove grille by unscrewing the 4 screws located along the perimeter of the inlet grille at roughly 2, 5, 7, and 10 o'clock positions. This will release the grille. To reattach, position grille so the logo in the center of the grille is straight. Align the Locator Pin to reconnect grille. Once aligned replace screws.
2. Dust or wash with a mild dishwashing soap. Do not place grille in the dishwasher. The excessive heat can distort the plastic.

## BLADE REMOVAL

1. It is possible to remove the blade should something accidentally get wrapped around the motor shaft. First, remove the nut from the shaft. Turn the nut **clockwise** to loosen. Pull the blade straight out from the shaft. When replacing, the blade can only go on the shaft one way. Be certain the flat side of the shaft aligns directly with the corresponding flat side on the blade's socket. Push the blade all the way on the shaft until it bottoms out. Do not use a hammer as this could result in bearing damage. Reinstall nut.
2. Wipe blade with a damp cloth. If your Air Circulator is used in a greasy environment, such as a kitchen, mild soap or a common household cleaner may be necessary. Do not use solvents.

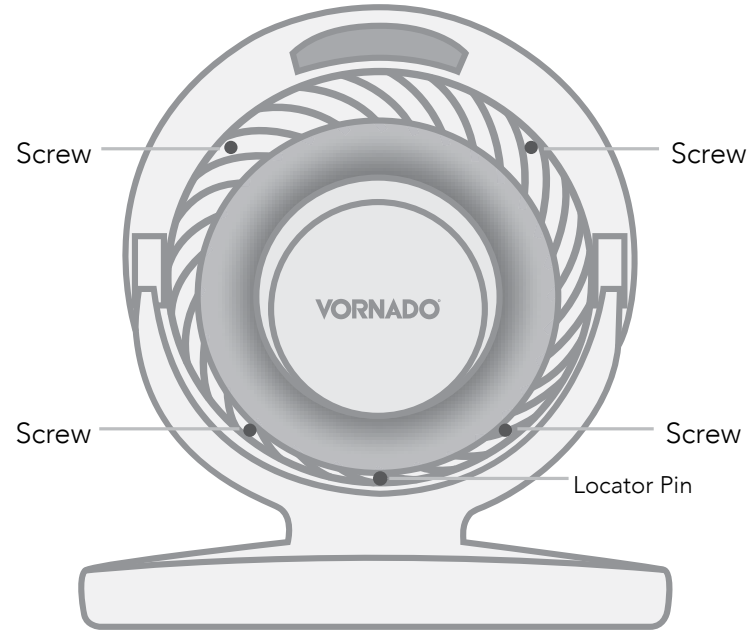

# CLEANING

Because your product moves a substantial amount of air, it will need regular cleaning to remove lint, dust and grime. Never clean the product in any manner other than instructed in this owner's guide.



## WARNING

**Observe the following safety information to avoid risks and property damage.**

- **Do** unplug your product before cleaning.
- **Do Not** use gasoline, thinners, solvents, ammonias or other chemicals for cleaning.
- **Do Not** attempt to repair or replace parts.



The motor is permanently lubricated and requires no oiling.

1. Dust or wipe the circulator with a damp cloth.
2. Use the brush attachment on your household vacuum cleaner to vacuum any accumulated dust.

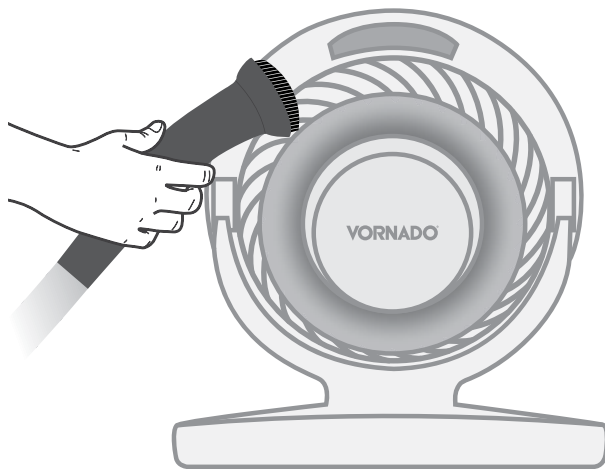



# TROUBLESHOOTING

## PROBLEM

## POSSIBLE CAUSE AND SOLUTION

The unit fails to power on.

Unit is not plugged in. Plug Power Cord into electrical outlet. Model 6803DC Only - Ensure the AC power cord is plugged into the power supply and ensure DC power cord is plugged into the circulator.

Ensure unit fan speed setting is selected.

Plug fuse has blown (USA Models 5303DC, 6303DC Only). Replace fuse. See USER SERVICING INSTRUCTIONS.

Unit is damaged or in need of repair. Cease usage and unplug. Contact Consumer Service for assistance.

The outlet is worn or damaged. Try another outlet or contact a qualified electrician.

Airflow is weak or slow.

Unit set to a low speed setting. Adjust to a higher speed setting.

Airflow is blocked. Remove obstruction.

Adjust direction of airflow towards the user.

GFCI has tripped.

Under certain conditions, it is possible for a reset GFCI (Ground Fault Circuit Interrupter) outlet to trip when the user is changing speeds on a Vornado circulator. In this event, change to an outlet that is not connected to a GFCI device. It could also indicate a weak or defective GFCI outlet. Contact a qualified electrician to check the GFCI outlet.

Remote control is not working.

The battery is dead. Replace with (1) new 3 volt CR2032 battery. Refer to REMOTE CONTROL.

The remote requires a line-of-sight path to allow for the signal to be received by the unit. Position the unit so the receiver lens (located inside the display panel) is visible from the remote control.

# DÉPANNAGE

## PROBLÈME

## CAUSE POSSIBLE ET SOLUTION

L'appareil ne se met pas sous tension.

L'appareil n'est pas branché. Branchez le cordon d'alimentation dans une prise électrique. Modèle 6803DC seulement – Assurez-vous que le cordon d'alimentation CA est branché dans le bloc d'alimentation et que le cordon d'alimentation CC est branché dans le ventilateur.

Assurez-vous d'avoir sélectionné un réglage de vitesse.

Le fusible de la fiche électrique a sauté (modèles des É.-U. seulement 5303DC, 6303DC, 7503DC). Remplacez le fusible (voir INSTRUCTIONS DE RÉPARATION À L'INTENTION DE L'UTILISATEUR).

L'appareil est endommagé ou il doit être réparé. Cessez d'utiliser l'appareil et débranchez-le. Contactez le service à la clientèle pour obtenir de l'aide.

La prise est usée ou endommagée. Utilisez une autre prise ou contactez un électricien compétent.

La circulation d'air est faible ou lente.

L'appareil a été réglé à vitesse faible. Utilisez une vitesse plus élevée.

La circulation d'air est entravée. Enlevez ce qui entrave la circulation d'air.

Dirigez la circulation d'air vers l'utilisateur.

Le DDFT a été déclenché.

Dans certaines conditions, il est possible qu'un DDFT (disjoncteur de fuite de terre) avec touche de réinitialisation soit déclenché quand l'utilisateur change la vitesse d'un ventilateur Vornado. Dans ce cas, branchez l'appareil dans une prise non reliée à un DDFT. Le problème peut aussi indiquer que la prise reliée au DDFT est faible ou défectueuse. Contactez un électricien compétent pour faire vérifier la prise reliée au DDFT.

La télécommande ne fonctionne pas.

La pile est morte. Remplacez-la par une (1) nouvelle pile CR2032 de 3 volts. Voir TÉLÉCOMMANDE.

Pour que l'appareil capte le signal de la télécommande, aucun obstacle ne doit entraver la portée optique de la télécommande. Placez l'appareil de façon que la lentille du récepteur (située à l'intérieur du tableau de l'afficheur) soit visible à partir de la télécommande.



# GARANTIE

Nous espérons que ce produit est parfait. Si vous n'êtes pas satisfait avec ce produit, faites-nous savoir.

Nous Sommes Là Pour Aider  
800.234.0604  
vornado.com  
help@vornado.com

Vornado Air LLC ("Vornado") garantit au consommateur ou acheteur original cela Vornado ® ensemble salle circulateur ("produit") est exempt de tout défaut de matériau ou de fabrication pendant une période de dix (10) ans à compter de la date d'achat. Si un tel défaut est découvert pendant la période de garantie, Vornado, à son gré, réparera ou remplacera le produit sans frais.

#### Pour réparation sous garantie ou service :

Appelez le 1-800-234-0604 ou par courriel [help@vornado.com](mailto:help@vornado.com) pour obtenir un formulaire d'autorisation de retour ("RA"). S'il vous plaît avoir ou inclure le numéro de modèle de votre produit et le numéro de série, ainsi que votre nom, adresse, ville, État, code postal et numéro de téléphone lorsque vous communiquez avec Vornado service sous garantie.

#### Après avoir reçu le formulaire RA, expédier votre produit à :

Vornado Air LLC Attn: Garantie & réparation 415 East 13th Street Andover, KS 67002. Pour votre commodité, veuillez avoir votre numéro de modèle et le numéro de série lorsque vous communiquez avec Vornado avec les demandes de service. Afin d'assurer une gestion correcte, paquets doivent porter clairement le numéro RA. Paquets non clairement marqués du numéro RA peuvent être refusés au quai de réception. S'il vous plaît permettre 1-2 semaines pour la réparation et le retour de votre produit après réception du produit.

Réparations non couvertes par la garantie ou en dehors de la période de garantie exigera une taxe pour couvrir le coût des matériaux, main de œuvre, de manutention et d'expédition. Cette garantie ne s'applique pas aux défauts résultant de l'abus du produit, modification, altération, réparation ou entretien du produit par quiconque autre que Vornado, manipulation inadéquate, une mauvaise maintenance, commercial l'utilisation du produit, les dommages qui se

produisent lors de l'expédition ou sont attribuées aux cas de force majeure. RÉPARATION OU REMPLACEMENT SELON LES TERMES DE CETTE GARANTIE EST LE RECOURS EXCLUSIF DU CONSOMMATEUR. VORNADO DÉCLINE TOUTE RESPONSABILITÉ POUR TOUT DOMMAGE INDIRECT POUR VIOLATION DE TOUTE GARANTIE EXPRESSE OU IMPLICITE SUR CE PRODUIT. SAUF DANS LA MESURE INTERDITE PAR LA LOI APPLICABLE, TOUTE GARANTIE IMPLICITE DE QUALITÉ MARCHANDE OU D'ADEQUATION A UN USAGE PARTICULIER SUR CE PRODUIT EST LIMITÉE À LA DURÉE DE CETTE GARANTIE. Certains États ne pas permettre l'exclusion ou la limitation des dommages accessoires ou indirects, ou permettent la limitation sur la durée des garanties implicites, il est possible donc les limitations ou exclusions ci-dessus peuvent ne pas vous concerner. Cette garantie vous donne des droits légaux spécifiques et vous pouvez avoir d'autres droits qui varient d'un État à l'autre.

Tous les noms de sociétés et noms de produit sont des marques déposées de leurs propriétaires respectifs. © Tous droits réservés. Toutes les informations techniques, données et instructions pour l'installation, le raccordement et l'exploitation contenues dans ces instructions d'utilisation correspondent aux informations plus récentes disponibles au moment de l'impression. Le contenu de ce manuel peut-être différer légèrement du produit réel. Observer tous les suppléments additionnels.

Le fabricant n'assume aucune responsabilité pour les dommages résultant du non-respect de ces instructions ou produit une mauvaise utilisation. Toute cette action annulera la garantie du produit.

Toute modification du produit non homologué, réparation par un centre de réparation non autorisée, ou l'utilisation de pièces de rechange non agréée n'est pas recommandée et toutes les conséquences ne seront pas couverts par les services d'assistance ou de garanties du produit.



Conception, mise au point et soutien technique effectués à Andover, au KS.

© 2021 Vornado Air LLC Andover, KS 67002 É.U. Brevet en instance. Spécifications sujettes à modification sans préavis. Vornado ® est une marque détenue par Vornado Air LLC.

# 10 YEAR

SATISFACTION  
GUARANTEE

# OUR WARRANTY

Vornado Air LLC (“Vornado”) warrants to the original consumer or purchaser this Vornado® Whole Room Circulator (“Product”) is free from defects in material or workmanship for a period of ten (10) years from the date of purchase. If any such defect is discovered within the warranty period, Vornado, at its discretion, will repair or replace the Product at no cost.

**For warranty or repair service:** Call 1-800-234-0604 or email [help@vornado.com](mailto:help@vornado.com) to obtain a Return Authorization (“RA”) form. Please have or include your Product’s model number and serial number, as well as your name, address, city, state, zip code and phone number when contacting Vornado for warranty service.

**After receiving the RA form, ship your Product to: Vornado Air LLC Attn: Warranty & Repair** 415 East 13th Street Andover, KS 67002. For your convenience, please have your model number and serial number when contacting Vornado with service inquiries. To assure proper handling, packages must be clearly marked with the RA number. Packages not clearly marked with the RA number may be refused at the receiving dock. Please allow 1-2 weeks for repair and return of your Product after the Product is received.

Repairs not covered by the warranty or outside the warranty period will require a fee to cover the cost of materials, labor, handling and shipping.

This warranty does not apply to defects resulting from abuse of the Product, modification, alteration, mishandling, improper maintenance, commercial use or repair or service of the Product by anyone other than Vornado; damages which occur in shipment or are attributed to acts of God. Improper product use, which includes using an external device that alters or converts the voltage or frequency

of electricity, or shipping a Vornado product to a country not intended for use will void all warranties. Any unauthorized product modification, repair by unauthorized repair center, or use of non-approved replacement parts is not recommended and any consequences will not be covered by support services or product warranties. The product warranty will be honored only on models that are being used in the country intended. REPAIR OR REPLACEMENT AS PROVIDED UNDER THIS WARRANTY IS THE EXCLUSIVE REMEDY OF THE CONSUMER. VORNADO SHALL NOT BE LIABLE FOR ANY INCIDENTAL OR CONSEQUENTIAL DAMAGES FOR BREACH OF ANY EXPRESS OR IMPLIED WARRANTY ON THIS PRODUCT. EXCEPT TO THE EXTENT PROHIBITED BY APPLICABLE LAW, ANY IMPLIED WARRANTY OF MERCHANTABILITY OR FITNESS FOR A PARTICULAR PURPOSE ON THIS PRODUCT IS LIMITED IN DURATION TO THE DURATION OF THIS WARRANTY. Some states do not allow the exclusion or limitation of incidental or consequential damages, or allow limitations on how long an implied warranty lasts, so the above limitations or exclusions may not apply to you. This warranty gives you specific legal rights, and you may have other rights that vary from state to state. The manufacturer assumes no responsibility for damage caused by failure to follow these instructions or improper product use. Any such actions will invalidate the product warranty.

All company names and product names are trademarks of their respective owners. © All rights reserved. All technical information, data, and instructions for the installation, connection, and operation contained in these instructions for use correspond to the latest available information at time of printing. The contents of this manual may differ slightly from the actual product. Observe any additional supplements.



Designed, engineered and supported in Andover, KS

© 2021 Vornado Air LLC Andover, KS 67002 U.S. Patent Pending. Specifications subject to change without notice. Vornado® is a trademark owned by Vornado Air LLC.

# ENERGY SMART



## MORE ENERGY EFFICIENT

Más eficiencia energética  
Plus économe en énergie



## MORE POWERFUL AIRFLOW

Flujo de aire más potente  
Plus puissant flux d'air



## PRECISE SPEED CONTROL

Control preciso de velocidad  
Le contrôle précis de la vitesse

# 10 YEAR

## SATISFACTION GUARANTEE

Satisfacción garantizada  
Satisfaction garantie