

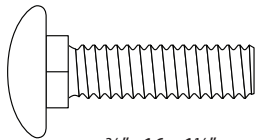

## ASSEMBLY SHEET: ULRF72-PERF

# 6' PERFORATED ROLLFORM U-LEG BENCH

parts

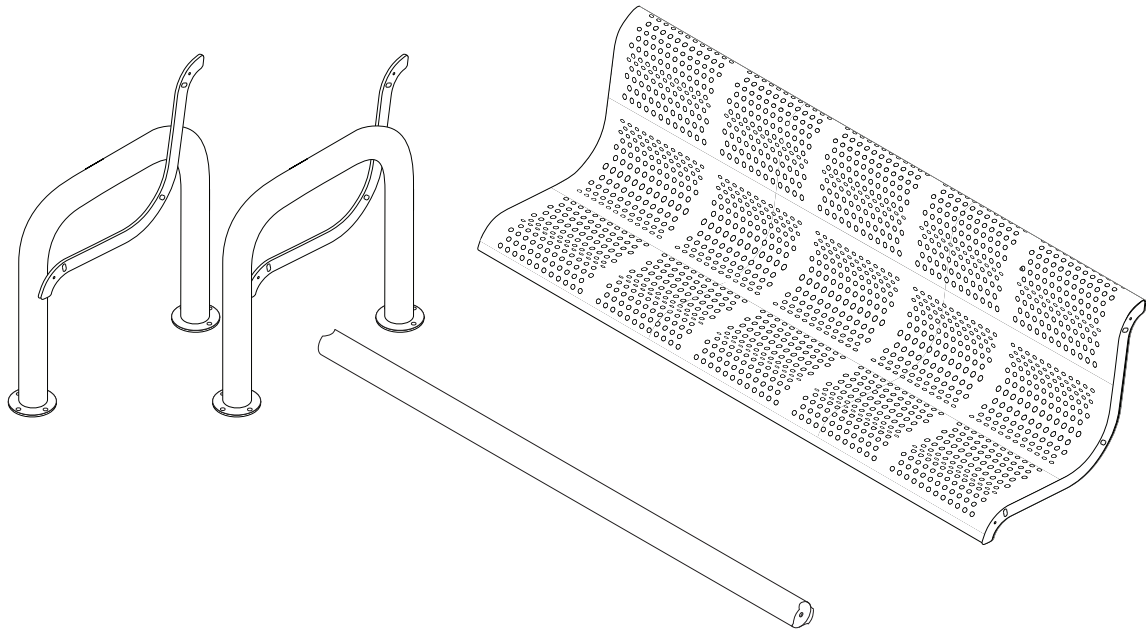

3/8" - 16 x 1 1/2"  
Carriage Bolt

**-6**

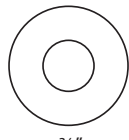

3/8"  
Washer

**-6**

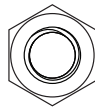

3/8"  
Nut

**-6**

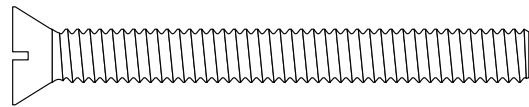

3/8" - 16 x 4"  
Slotted Machine Screw

**-2**

### tools needed

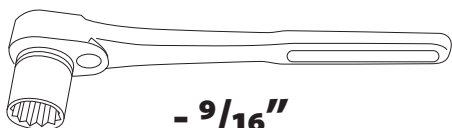

**- 9/16"**

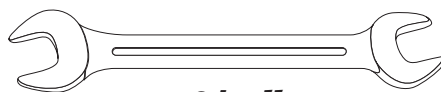

**- 9/16"**

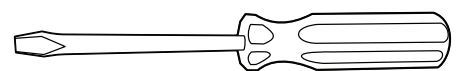

**Note:** finger tighten all bolts and nuts until parts are adjusted for fit before tightening with tools.

1

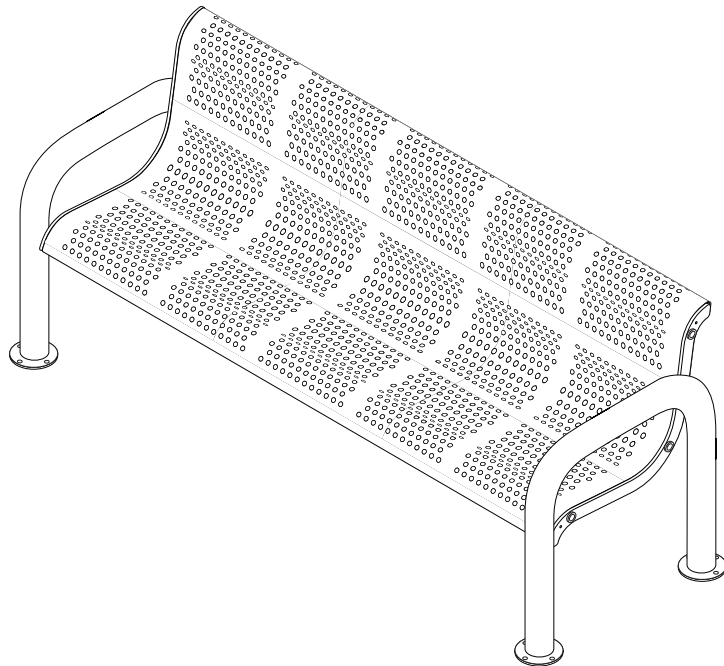
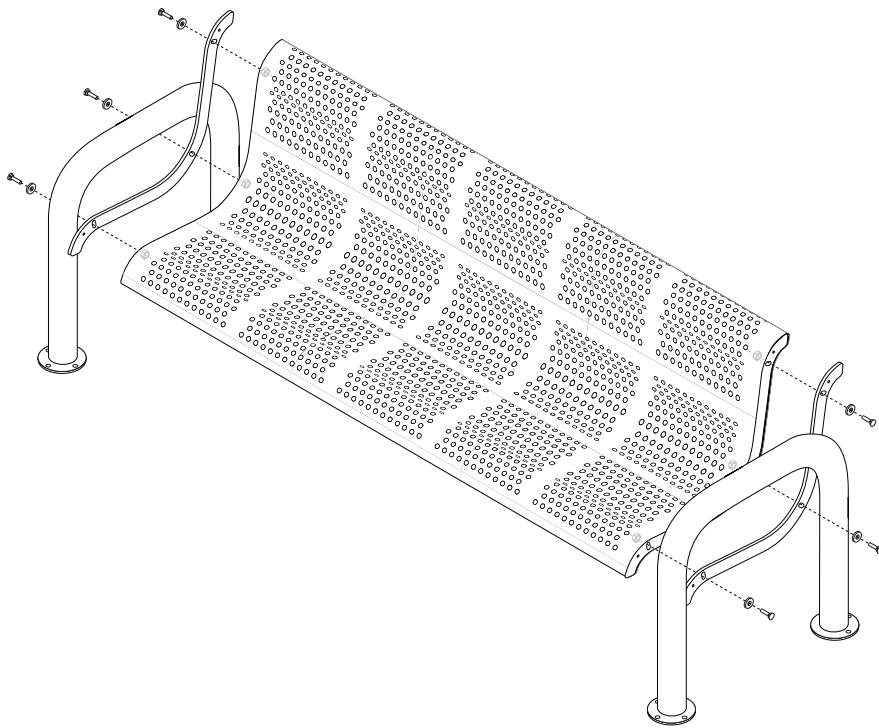

assembly - lower back brace into place & attach

2

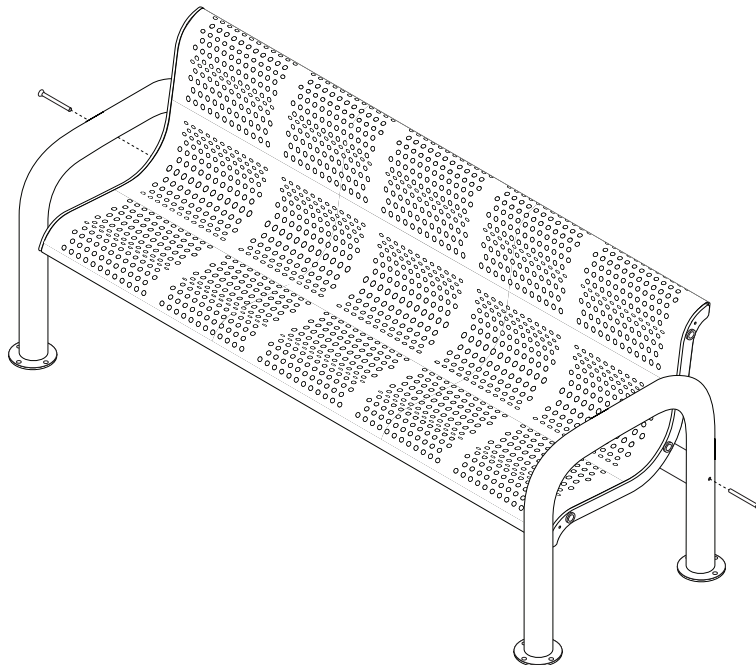
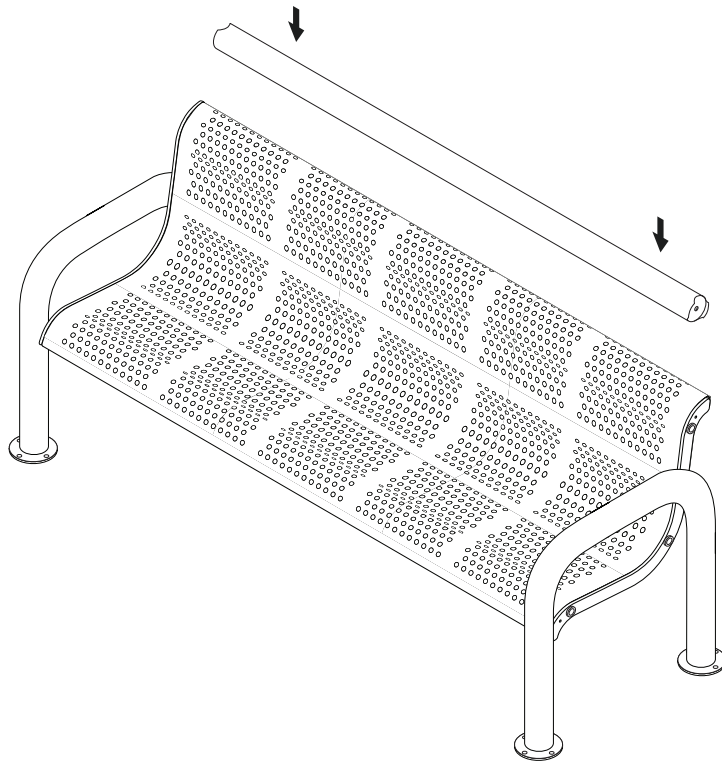

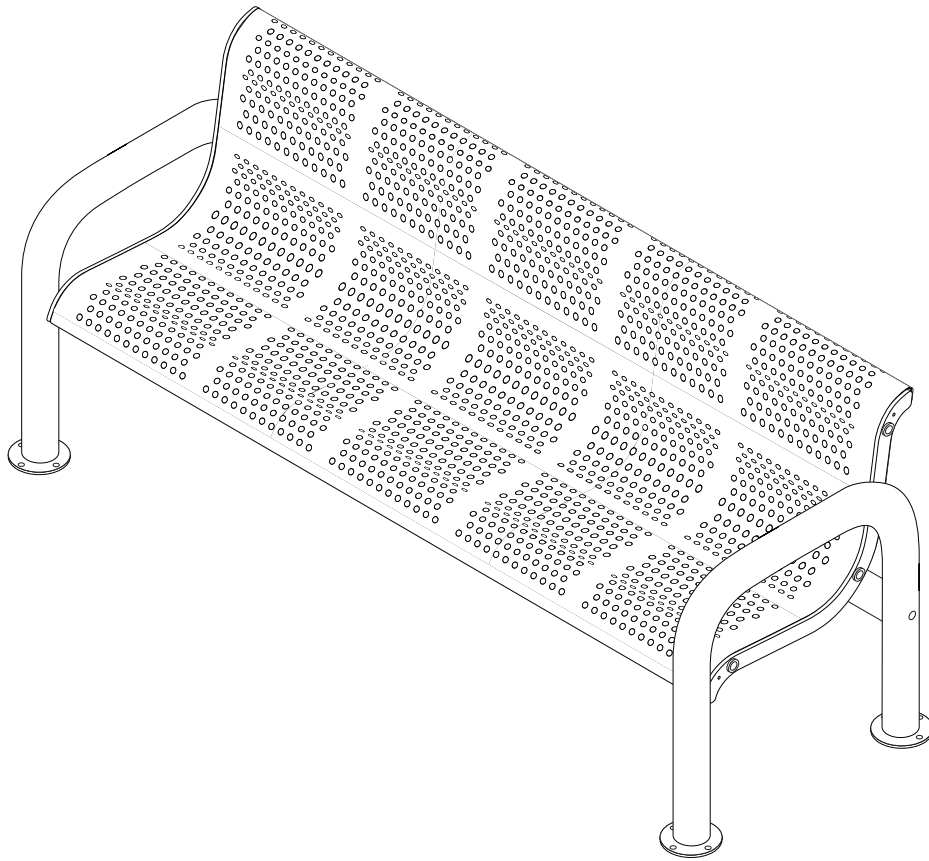

**Maintenance:**  $\frac{3}{8}$ " bolts should be tightened to 15 lbs-ft. The bench should be serviced annually to verify all bolts are tightened to correct specification and that all other parts are in working order.

