

### IMPORTANT RECEIVING INSTRUCTIONS

Visually inspect all components for shipping damage. If shipping damage is found, notify carrier at once. Shipping damage is NOT covered by warranty. The carrier is responsible for all repair and replacement costs resulting from damage in shipment.

### SAFETY ISSUES

**IMPORTANT – USER SAFETY AND PROTECTION:** In setting up systems to fit your operations, care must be taken to select the proper components and design to insure appropriate that all safety measures have been taken to avoid the risk of personal injury and property damage from your application or system.

**GARDNER BENDER IS NOT RESPONSIBLE FOR DAMAGE OR INJURY CAUSED BY UNSAFE USE, MAINTENANCE OR THE APPLICATION OF ITS PRODUCTS.** Please contact Gardner Bender for guidance when you are in doubt as to the proper safety precautions to be taken in designing and setting up your particular application.

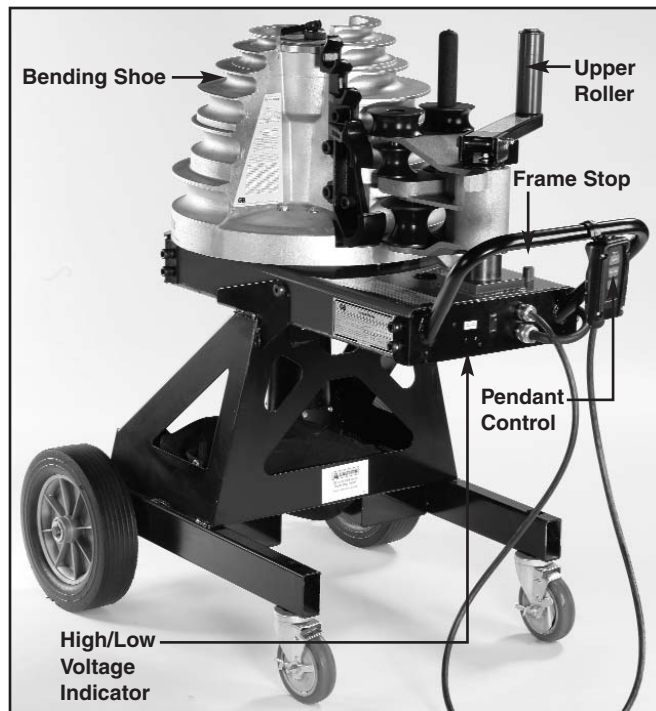

Figure 1. B2000 Cyclone® Bender

### 1.0 DESCRIPTION

The Cyclone®, GB model B2000 production bender is used to bend EMT, IMC, rigid steel or rigid aluminum conduit. A single bending shoe accommodates sizes 1/2", 3/4", 1", 1 1/4", 1 1/2" and 2" conduit. The shoe is driven by a 115 V, 15 A motor. The roller housing consists of a single urethane roller support arm, and three sets of nylon rollers.

The bender control pendant consists of a zero light, a green power light, a jog push button, a push button for "Bend and Return". An 8' electrical cord connects the pendant to the bender frame. The bender can be used in a horizontal or vertical position.

The end plate contains an ON-OFF switch which is also a circuit breaker. When the switch is turned on, the two leds will flash red, then green to indicate normal function.

To avoid damaging the bender control circuit, an input voltage sensing system is built into the control circuit. If input voltage is less than 92 VAC or higher than 132 VAC the bender will shut off. One of the two LEDs located on the end plate will light to indicate whether high or low voltage exists.

Re-set the bender by turning unit off then on again. If the incoming current voltage has not been corrected, the bender will not operate. The voltage range must be within 92 VAC to 132 VAC. Any situation which causes a voltage drop or increase must be corrected before using the B2000 Bender.

Voltage drops may be caused by:

- Extension cords that are too long.
- Extension cords made of light (16-18 gauge) wire.
- Multiple power tools on a single circuit.
- Other devices which require high amperes to operate.

### 2.0 WARNINGS

**⚠ CAUTION:** During pipe bending, stand behind the frame handle. Keep hands, clothing and control cord away from the bending shoe and rollers.

**⚠ WARNING:** Do not operate the bender on damp or wet surfaces. Do not stand on wet surfaces while operating the bender.

**⚠ CAUTION:** To prevent damage to the bending shoe, do not allow the clamping jaws to strike the upper roller support arm when the shoe is rotating. Position the roller housing against the frame stop. See Figure 1.

**⚠ CAUTION:** Select an operating area large enough to permit loading pipe section and bending without striking objects or personnel.

**⚠ WARNING:** To avoid possible injury, do not place fingers under the bottom edge of the bending shoe. See Figure 2.

**⚠ CAUTION:** Do not attempt to bend conduit or pipe other than 1/2" through 2" IMC, EMT, rigid steel or aluminum. Bending other materials will damage the bender and void the warranty.

**NOTE:** All operations referring to "toward the operator" are viewed from the lifting handle end of the bender frame.

### 3.0 SPECIFICATIONS

Power Source .....	120 V 60 cycle AC
Pendant Control Circuit .....	12 VDC
Motor .....	1 HP 100 V 60 cycle DC
Weight .....	408 lbs.
Height .....	38 inches
Width .....	31 inches
Length.....	45 inches
Circuit Breaker.....	15 Amp
Bend Capability .....	1/2" - 2" IMC, EMT Rigid Steel or Rigid Aluminum

### 4.0 OPERATION

#### 4.1 Bending 1/2", 3/4" and 1" IMC, EMT and rigid conduit:

1. Position the bender in a level dry area large enough to permit loading and unloading various lengths of conduit. Position the frame, either horizontally or vertically, by pulling the spring loaded pin on the side of the bender frame. See Figure 2.

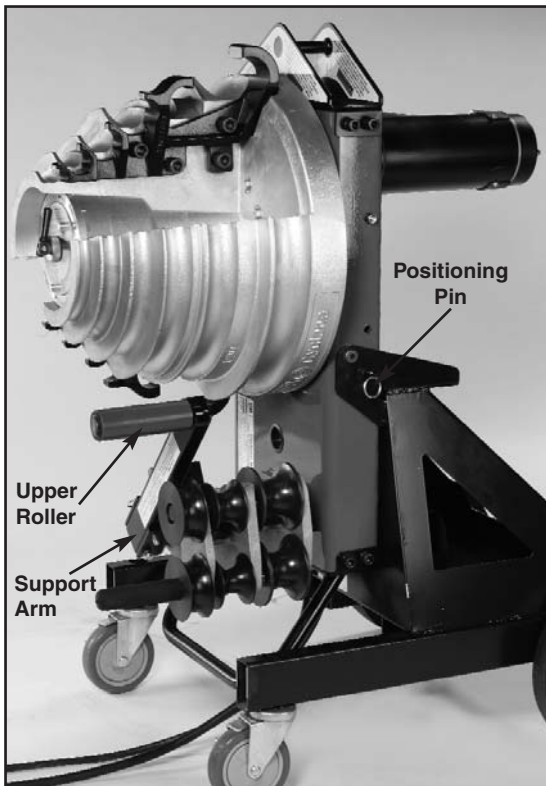

**Figure 2. Vertical Position**

2. Identify the type (IMC, EMT or Rigid) and size conduit to be bent.

3. Locate the markings that indicate which grooves are used for specific materials, and which grooves are used for specific size conduit. See Figure 3.

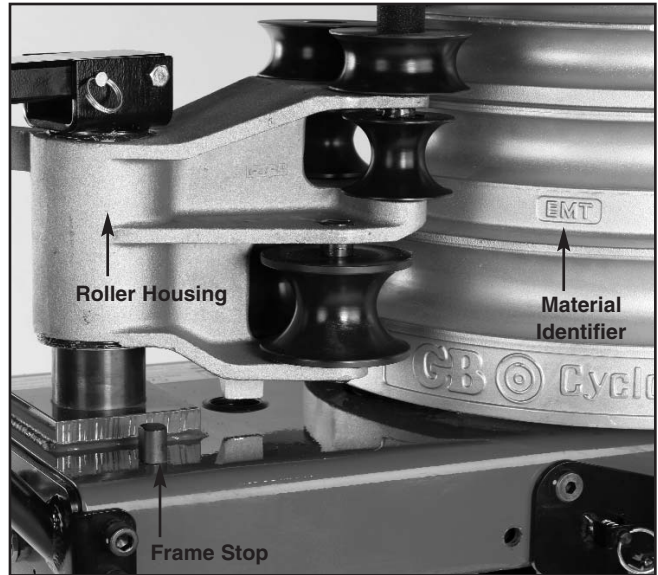

**Figure 3. Set Up**

**⚠ CAUTION:** To avoid damaging the rollers and roller housing, always place the roller housing against the frame stop prior to rotating the shoe.

4. Push the roller housing against the frame stop. See Figure 2. Rotate the shoe to bring the required grooves (EMT, IMC or Rigid) facing toward the operator. To activate the shoe, hold the pendant toggle switch in "Return" and press the jog button until the zero light goes out. The shoe will rotate and stop in the load position. The zero light will come on.
5. The upper urethane roller and support arm (See Figure 4) is used for bending 1/2" through 1" conduit. One of the top three shoe grooves will be used, depending on conduit size.

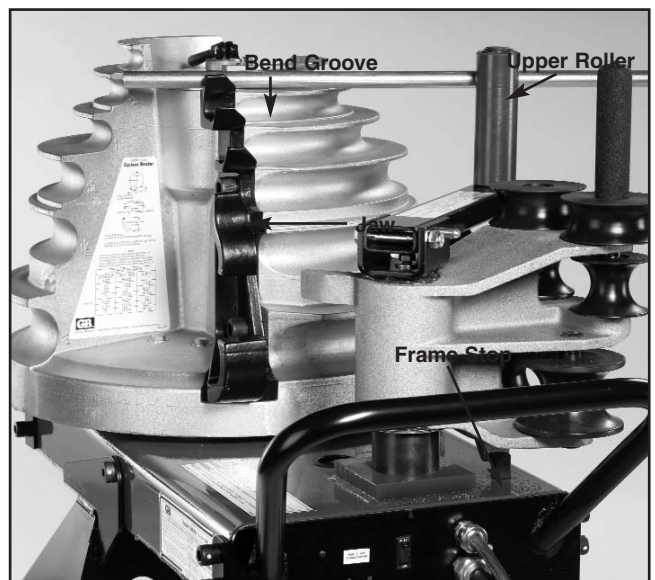

**Figure 4. Bending 1/2" - 1"**

6. When bending ½" - 1" conduit the upper roller and support arm must be positioned between the shoe and the roller housing. Position the urethane roller by moving the roller housing against the frame stop and removing the pin.
7. Lift the roller support arm to clear the nylon rollers and swing the arm (toward shoe) over the roller housing. Lower the arm into the support bracket and insert the ring pin. See Figure 5.

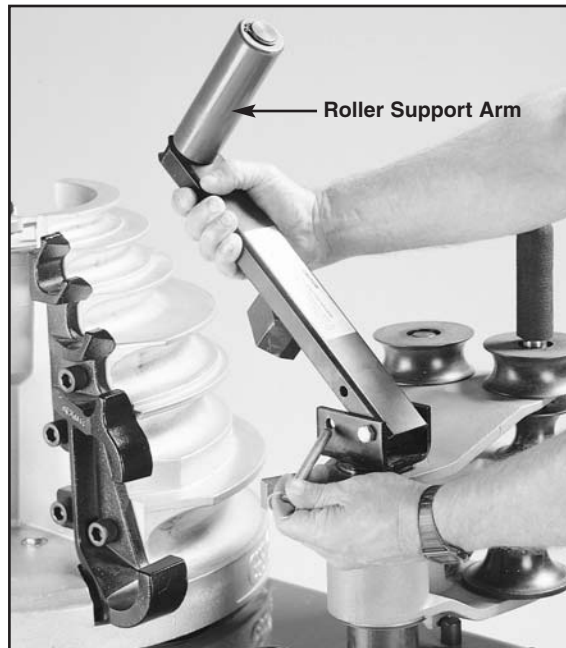

**Figure 5. Position Roller Support**

8. Insert the conduit in the shoe groove marked with the number matching the size conduit being bent. The conduit must set in the shoe and in the jaw. The end of the conduit must extend a minimum of 2" beyond the jaw. See Figure 3. Refer to table A or B on page 5 for bending data.
9. Each time a different size and type of conduit is being bent, three facts must be determined and set into the bender shoe control system. The required settings are: conduit size, material and desired bend angle. Prior to setting, be sure the desired size indicator scale is toward the operator and the correct shoe grooves are also toward the operator.
  - a. Lift the locking handle. See Figure 6. Use the two small pins to rotate the angle disc, clockwise, until the red zero line is directly in line with the zero line on the size scale.
  - b. Set the bender for specific conduit size by turning the angle disc until the red line is on the size indicator mark which matches the size conduit being bent. Be sure the correct size scale is being used (EMT, IMC, or Rigid).
  - c. Move the bend angle set knob (See Figure 6) until the flat edge of the pointer is on a line indicating the exact degree of bend desired. Lower the center arm to lock the pointer and scale and to prevent inadvertent movement during bending.

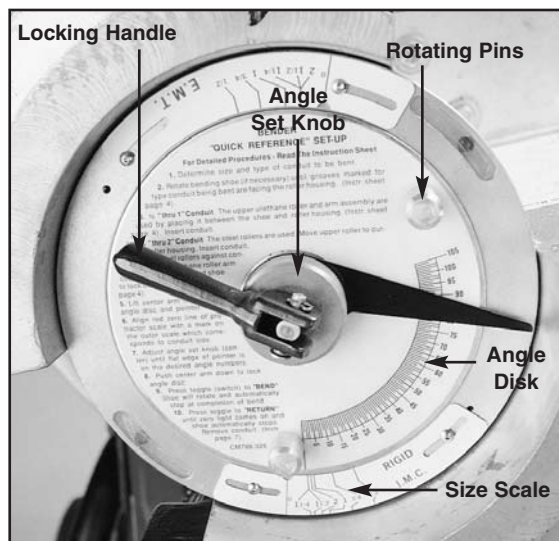

**Figure 6. Set Angle Scale**

10. Activate the bending shoe by holding the pendant control Bend button. The shoe will rotate until the angle set on the pointer is reached.
11. To remove the conduit, hold the "Return" button. The shoe will return to the start position and stop automatically. The zero set light will come on. Bending more conduit of the same type and size is accomplished by loading conduit and pressing the bend button.

#### 4.2 Bending 1¼", 1½" and 2" Conduit

NOTE: All operations referring to "toward the operator" are viewed from the lifting handle end of the bender frame.

1. Bending 1¼" through 2" requires using one of the three sets of nylon rollers and one of the grooves on the lower half of the bending shoe.
2. Move the roller housing against the frame stop. See Figure 11. The upper urethane roller must be on the outside (toward frame handle) of the roller housing. See Figure 7. If it's not, pull the ring pin. Lift the roller support arm, swing it over the roller housing, lower the handle into the bracket and insert the ring pin.

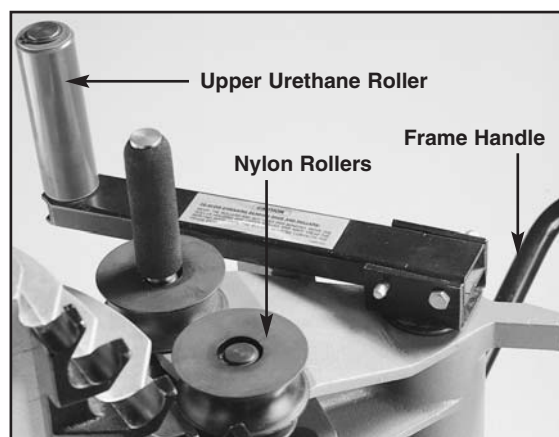

**Figure 7. Position Roller Support**

**⚠ CAUTION:** To avoid damage to the bending shoe, always place the roller housing against the frame stop, prior to activating the bending shoe.

3. Check the bending shoe to be sure the correct grooves for the conduit being bent are facing toward the operator. If the shoe must be rotated, hold the pendant control Return button and press the jog button until the zero light goes out. The shoe will rotate 180° then stop in the load position. See Figure 8. The zero light will come on.



**Figure 8. Pendant Control**

4. When bending 1 1/4" - 2" conduit, position roller housing and upper arm. Then push the conduit between the shoe groove and the 2" nylon rollers until the bend mark on the conduit is in line with the outside edge of the clamp jaw.
5. Grasp the upper urethane roller and move the support arm counterclockwise until it contacts the roller housing. The two nylon rollers should have moved against the conduit and should firmly hold the conduit in the shoe. See Figure 9.

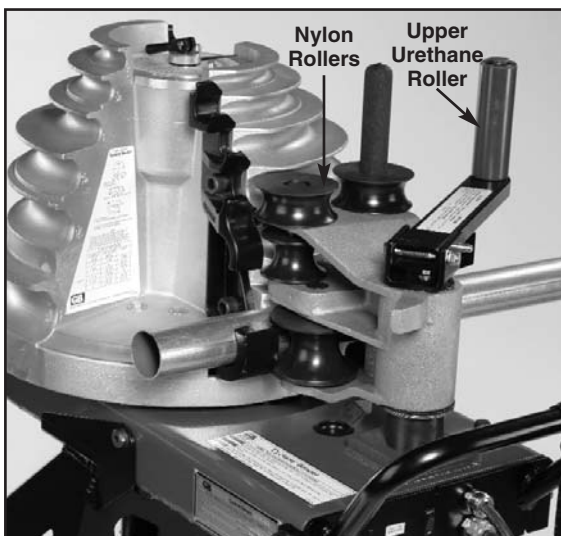

**Figure 9. Locking in Roller Support**

6. Each time a different size and type of conduit is being bent, three facts must be determined and set into the bender shoe control system. The required settings are: conduit size, material and desired bend angle. Prior to setting, be sure the pipe size scale is toward the operator and the correct shoe grooves are also toward the operator.
  - a. Lift the locking handle to release the angle set knob and angle disc. Use the two small pins to rotate the angle disc, clockwise. See Figure 10.

- b. Set the bender for specific conduit size by turning the angle disc until the red line is on an outer size scale mark which matches the size conduit being bent. See Figure 10. Be sure the correct size scale is being used (EMT, IMC, or Rigid).
- c. Move the angle set knob (See Figure 10) until the flat edge of the pointer is on the line indicating the exact degree of bend desired. Lower the center arm to lock the pointer, angle disc and to prevent inadvertent movement during bending.

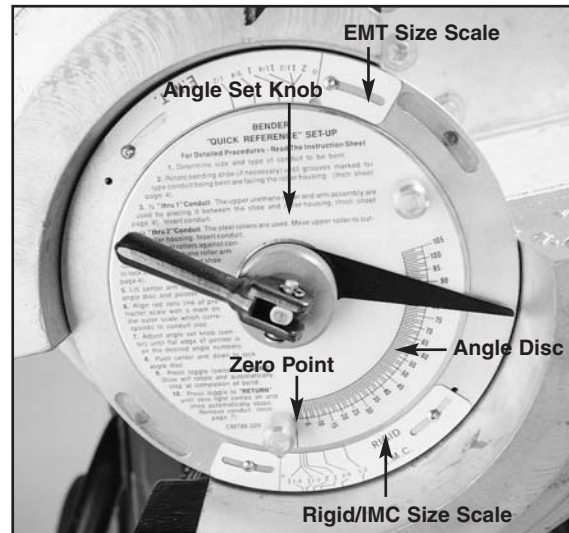

**Figure 10. Set Angle Indicator**

7. Use the control pendant. The zero light should be on. Hold the Bend button. The shoe will rotate until the desired bend is achieved, then stop automatically.
- NOTE: If the zero light is not on, press the Return button until the shoe stops and the zero light comes on.
8. To unload conduit, hold the Return button. The shoe will return to the start position and stop automatically.
  9. Grasp the upper urethane roller and move the support arm clockwise until the rollers move away from the conduit. See Figure 11. Push the roller housing against the frame stop. Remove bent conduit.

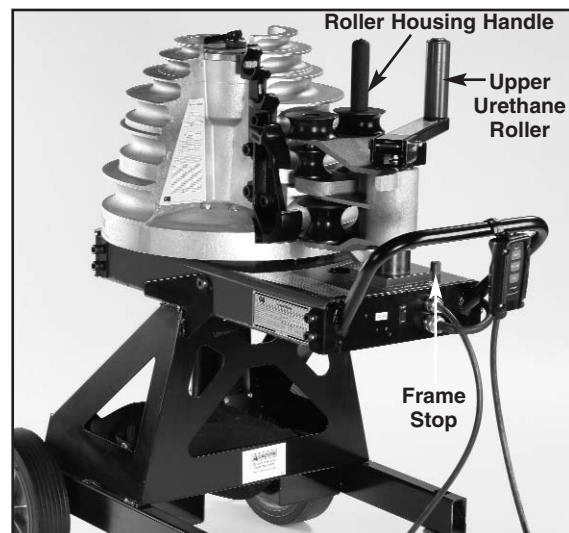
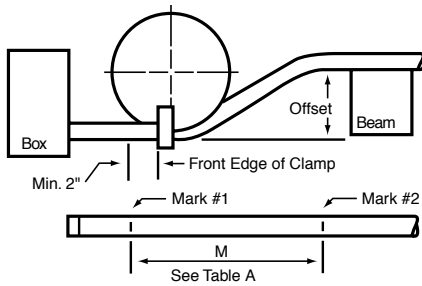

**Figure 11. Unload Conduit**

- To bend more conduit of the same material and at the same angle, load and secure as described in steps 3 through 6. To bend the same type conduit but at a different angle, load and secure; turn angle set knob to the desired angle, then press the bend button.
- Bending different type and size conduit requires repeating steps 2 through 10.

### 4.3 Offset Bending

- Obtain distance "M" from table A, and measure this distance from mark #1 and place mark #2.
- Now place mark #1 in line with front edge of shoe clamp and make first bend.
- Next rotate conduit 180° level, place mark #2 in line with front edge of shoe clamp and make second bend.



NOTE: When bending rigid aluminum, set bend angle indicator approximately 4° short of desired angle, since aluminum does not have spring-back of steel.

**Table A**

Offset Required	15° Bend		30° Bend		45° Bend	
	Conduit Max. Size	M	Conduit Max. Size	M	Conduit Max. Size	M
2"	3/4"	7 3/4"				
4"	1 1/2"	15 1/8"	3/4"	8"		
6"	2"	23 3/8"	1"	12"	1/2"	8 1/2"
8"		30 3/8"	1 1/2"	16"	1"	11 1/8"
10"		38 3/8"	2"	20"	1 1/2"	14 1/8"
12"		46 3/8"		24"	1 1/2"	16 1/8"
14"		54 1/8"		28"	2"	19 3/8"
16"		61 1/8"		32"		22 3/8"
18"		67 1/8"		36"		25 1/8"
20"		77 1/4"		40"		28 1/4"
22"		85"		44"		31 1/4"

To locate distance between centers of offset bending marks other than listed in table A use the following multipliers:  
 15° bend - 3.9  
 30° bend - 2.0  
 45° bend - 1.4

### 4.4 Stub-up Bending

- Table C shows minimum length (inches).
- Mark #1 is stub length, deduct from this as per table C and obtain mark #2.

**Table B**

Conduit Size	BEND RADIUS	
	Radius Rigid / IMC	Radius EMT
1/2"	3 1/2"	3 7/8"
3/4"	4 25/32"	4 29/32"
1"	5 5/16"	5 29/32"
1 1/4"	6 7/8"	7 3/32"
1 1/2"	7 7/16"	7 1/2"
2"	8 3/32"	8 9/16"

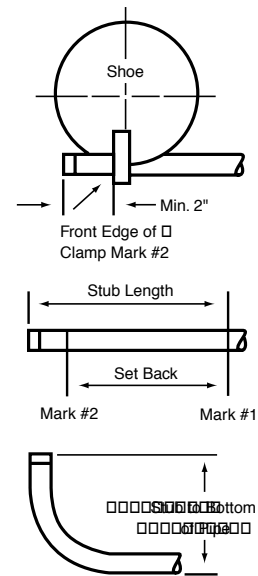

**Table C**

Conduit Size	Stub-up Set-back	Conduit Size	Stub-up Set-back
1/2"	Rigid 7 3/4"	1 1/4"	Rigid 12 3/4"
1/2"	IMC 7 3/4"	1 1/4"	IMC 12 1/2"
1/2"	EMT 7 3/4"	1 1/4"	EMT 13"
3/4"	Rigid 9"	1 1/2"	Rigid 13 1/2"
3/4"	IMC 9"	1 1/2"	IMC 13 1/2"
3/4"	EMT 8 1/2"	1 1/2"	EMT 13 1/2"
1"	Rigid 10 5/8"	2"	Rigid 15 1/4"
1"	IMC 10 5/8"	2"	IMC 15 1/2"
1"	EMT 10 5/8"	2"	EMT 15 1/2"

## 5.0 ANGLE ADJUSTMENT

Two different type scales are mounted on the shoe outer rim. One for ½" thru 2" IMC and Rigid, the other for EMT ½" thru 2" See Figure 12.

Each scale indicator is adjustable to compensate for over long or short bends which may be due to differences in conduit characteristics or other variations.

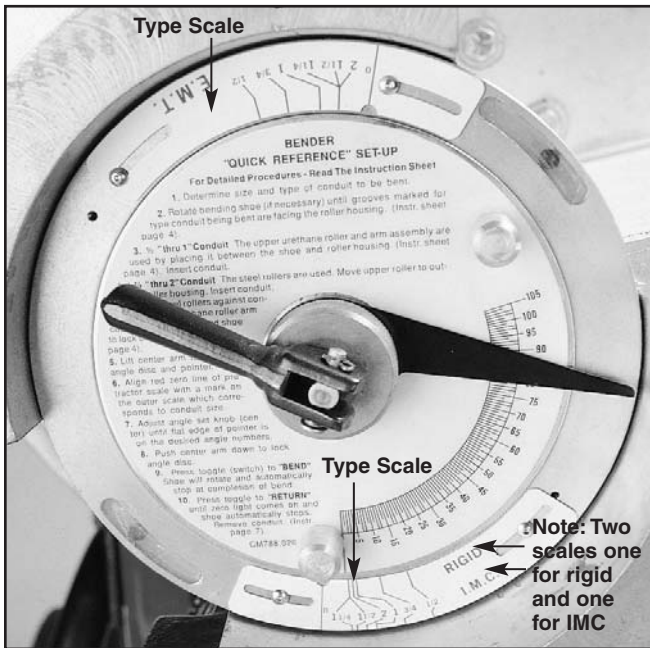

Figure 12. Two Type Scales

**Bends which are too long:** Loosen the size scale (for type material being bent) mounting screws. Slide the scale clockwise as many degrees as the overbend (if bend is 5° over, move indicator 5° clockwise). The degree of movement is observed by watching one of the size marks as it moves past the angle disc scale. Tighten the mounting screws.

**Bends which are too short:** Loosen the size scale (for type material being bent) mounting screws. Slide the scale counterclockwise as many degrees as the bend is short (if bend is 5° short move counterclockwise 5°). The degree movement is observed by watching one of the size marks as it moves past the angle disc scale. Tighten the mounting screws.

## 6.0 MAINTENANCE

A troubleshooting aid exists on the printed circuit board mounted to the inside of the operating handle. A white L.E.D. will flash once every two seconds after power up. The L.E.D. indicates all systems functional. See Figure 13.

Error codes consist of different light patterns.

1. Blink twice, pause, blink twice = the motor is over heated.
2. Blink 3 times, short pause, blink three times, long pause = limit switch has failed.
3. Blinks 4 times, short pause, blinks four times, long pause = pendant control malfunction.

In addition the L.E.D. will be steady on if the bend or return button is being pressed.

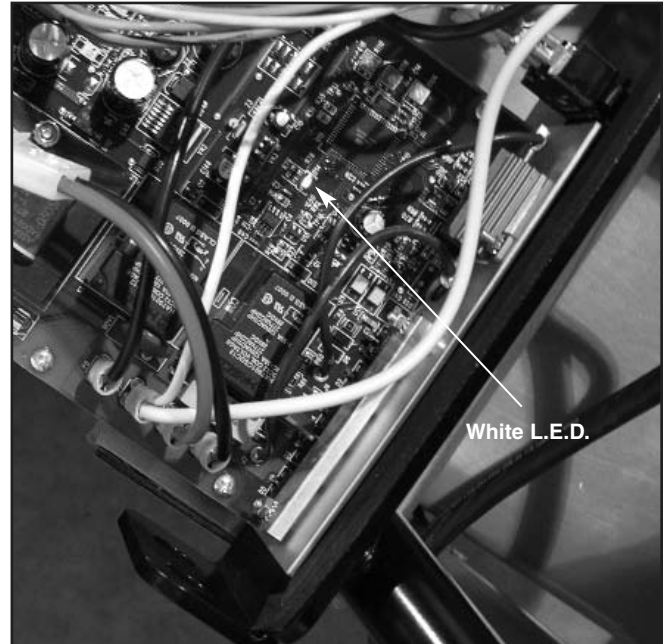

Figure 13. L.E.D. Location

**REPAIR AND SERVICE INSTRUCTIONS:** For repair service and parts contact your nearest Gardner Bender Service Center. The Gardner Bender Service Center will provide complete and prompt service on all Gardner Bender products.

**PARTS AND SERVICE:** For quality workmanship and genuine Gardner Bender parts, select an Authorized GB Service Center for your repair needs. Only repairs performed by an Authorized Service Center displaying the official GB Authorized sign are backed with full factory warranty. Contact Gardner Bender (414)352-4160 for the name of the nearest GB Authorized Service Center.

**WARRANTY:** Gardner Bender warrants its product against defects in workmanship and materials for 1 year from date of delivery to user. Chain is not warranted. Warranty does not cover ordinary wear and tear, abuse, misuse, overloading, altered products or use of improper fluid.

**WARRANTY RETURN PROCEDURE:** When question of warranty claim arises, send the unit to the nearest GB Authorized Service Center for inspection, transportation prepaid. Furnish evidence of purchase date. If the claim comes under the terms of our warranty the Authorized Service Center will REPAIR OR REPLACE PARTS AFFECTED and return the unit prepaid.

**GB**  
Gardner  
Bender

PO Box 3241 • Milwaukee, WI 53201-3241 • 414-352-4160 • Fax 414-352-2377  
6615 Ordan Drive • Mississauga, Ontario L5T 1X2 • 905-564-5749 • Fax 905-564-0305

RPS-0097 rA 01/06