

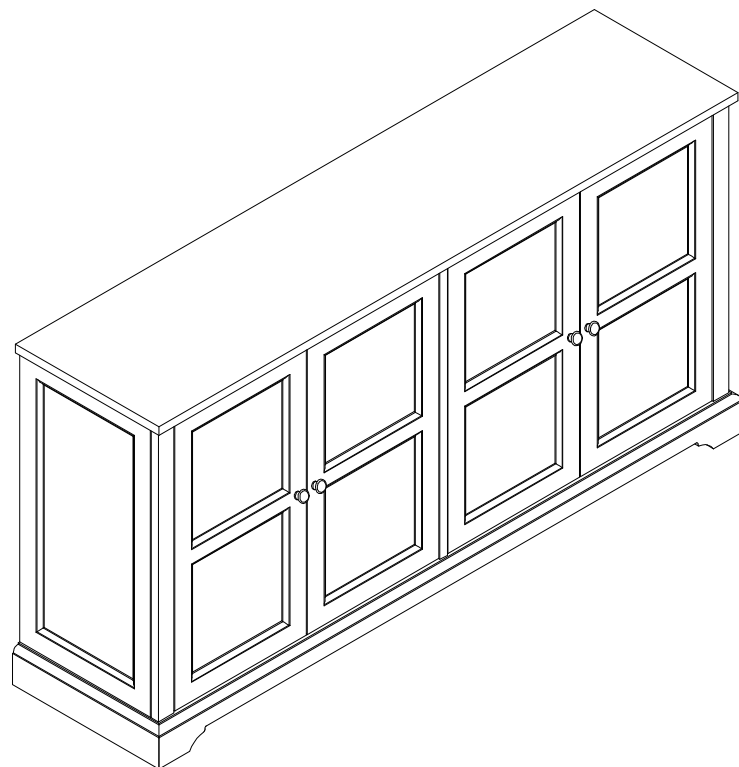

CROSLEY
FURNITURE

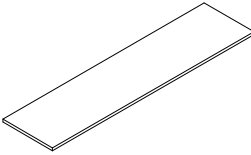

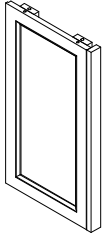

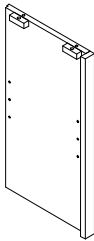
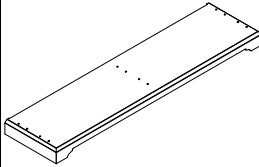
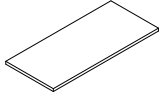
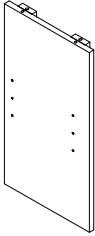
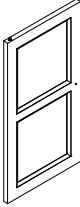
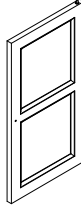

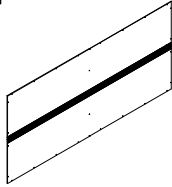





Sideboard
CF4222

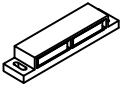

PART LIST

A 	B 	C 	D 	E 
Top Panel 1 PC	Left Panel 1 PC	Right Panel 1 PC	Bottom Panel 1 PC	Adjustable Shelf 2 PCS
F 	G 	H 	I 	J 
Partition Panel 1 PC	Left Door 2 PCS	Right Door 2 PCS	Support Leg 1 PC	Back Panel 1 PC

HARDWARE LIST

 1/4"x1-1/4" Bolt 12 PCS (Extra 1)	 1/4" Spring Washer 12 PCS (Extra 1)	 1/4"x16mm Flat Washer 12 PCS (Extra 1)	 8x30mm Wood Dowel 12 PCS (Extra 1)	 Knob 4 PCS
 5/32x25mm Round Head Bolt 4 PCS (Extra 1)	 Double Magnet 2 PCS	 3x14mm Round Head Screw 4 PCS (Extra 1)	 Shelf Holder 8 PCS (Extra 1)	 3x14mm Screw 26 PCS (Extra 1)
 M 4 Allen Wrench 1 PC	 Safety Strap Kit 1 SET			

ADDITIONAL TOOLS (Not Provided)

Note: It is not recommended to use power tools during assembly.

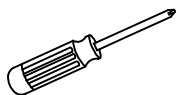

Phillips Head Screwdriver

Note: Wood dowels are intended for alignment. Additional clearance between wood dowel and pre-drilled hole is intentional for ease of assembly.

Step 1. Attach knobs (part #5) to doors (parts G & H) using round head bolts (part #6) and phillips head screwdriver. Attach double magnets (part #7) to top panel (part A) using round head screws (part #8) and phillips head screwdriver.

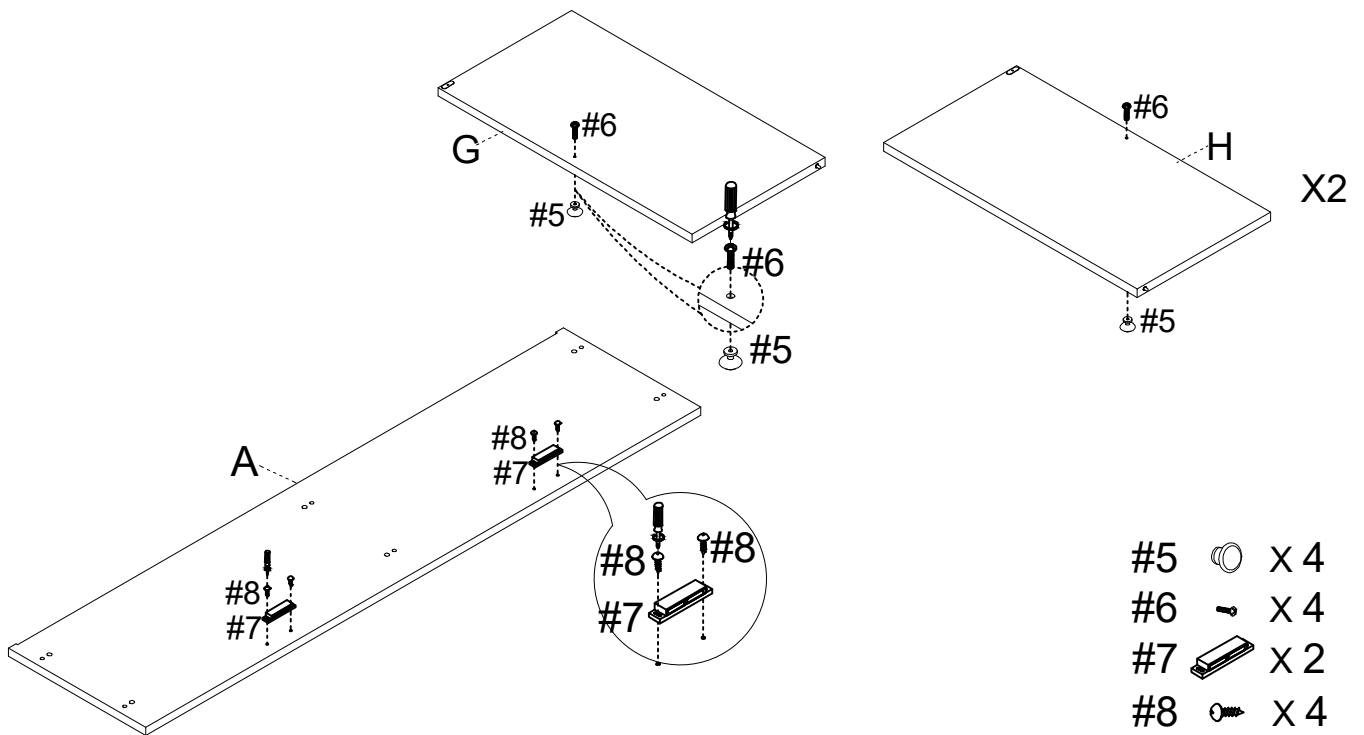

Step 2. Attach support leg (part I) to bottom panel (part D).

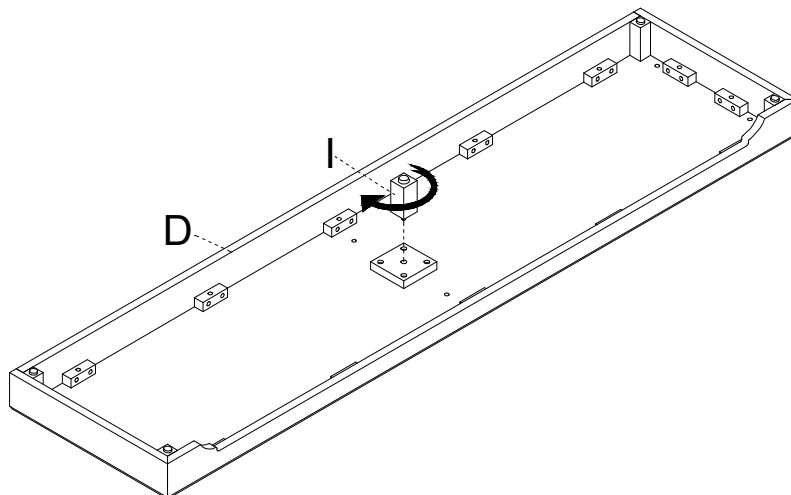

Step 3. Attach bottom panel (part D) to panels (parts B, C & F) using wood dowels (part #4), bolts (part #1), spring washers (part #2), flat washers (part #3) and allen wrench (part #11).

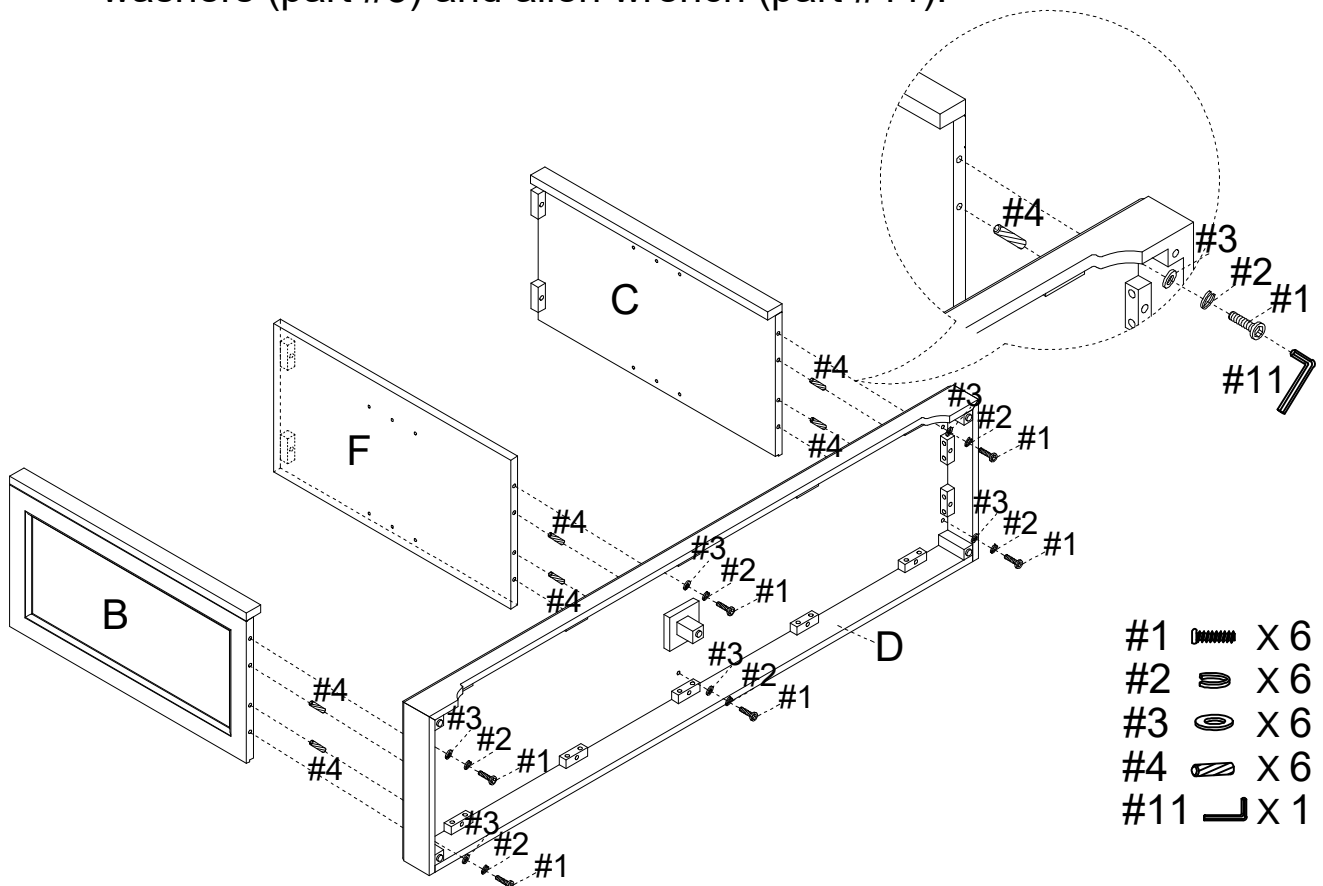

Step 4. Carefully turn unit upright. Attach top panel (part A) to assembled unit (parts B, C & F) using wood dowels (part #4), bolts (part #1), spring washers (part #2), flat washers (part #3) and allen wrench (part #11).

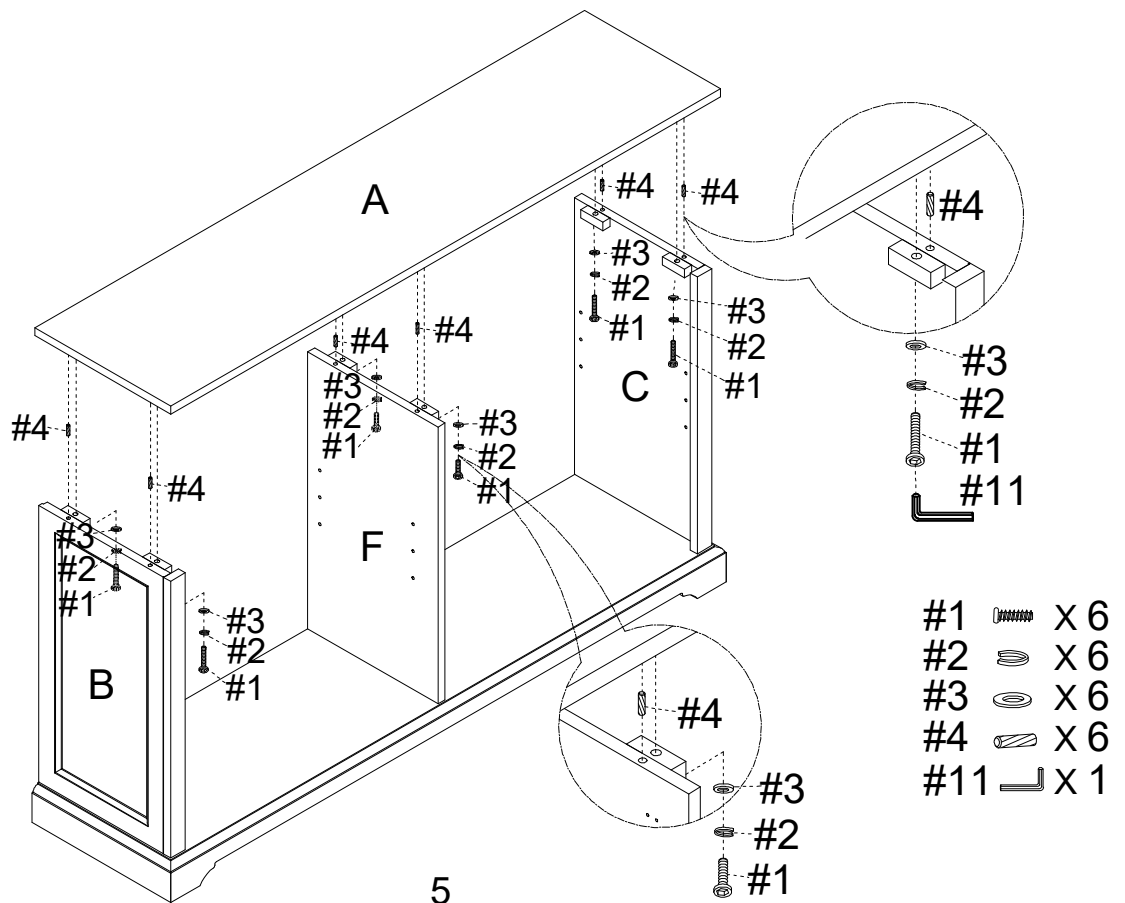

Step 5. Attach back panel (part J) to assembled unit (parts A, B, C, D & F) using screws (part #10) and phillips head screwdriver.

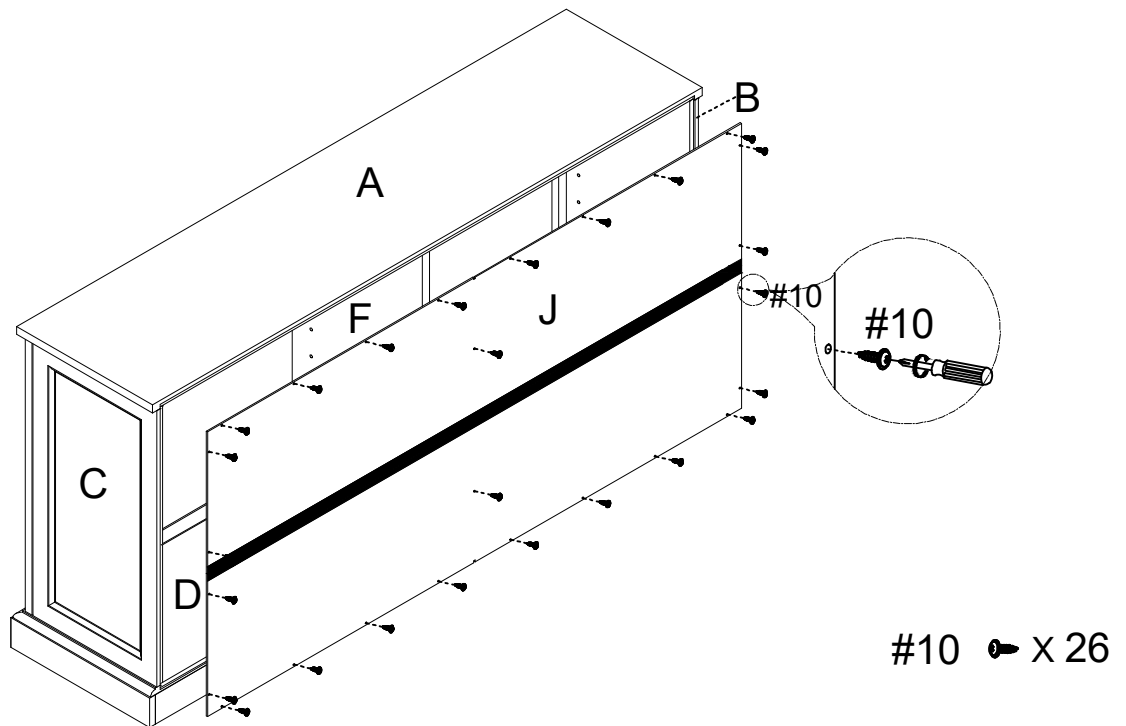

Step 6. Place shelf holders (part #9) into desired position and slide adjustable shelves (part E) into place.

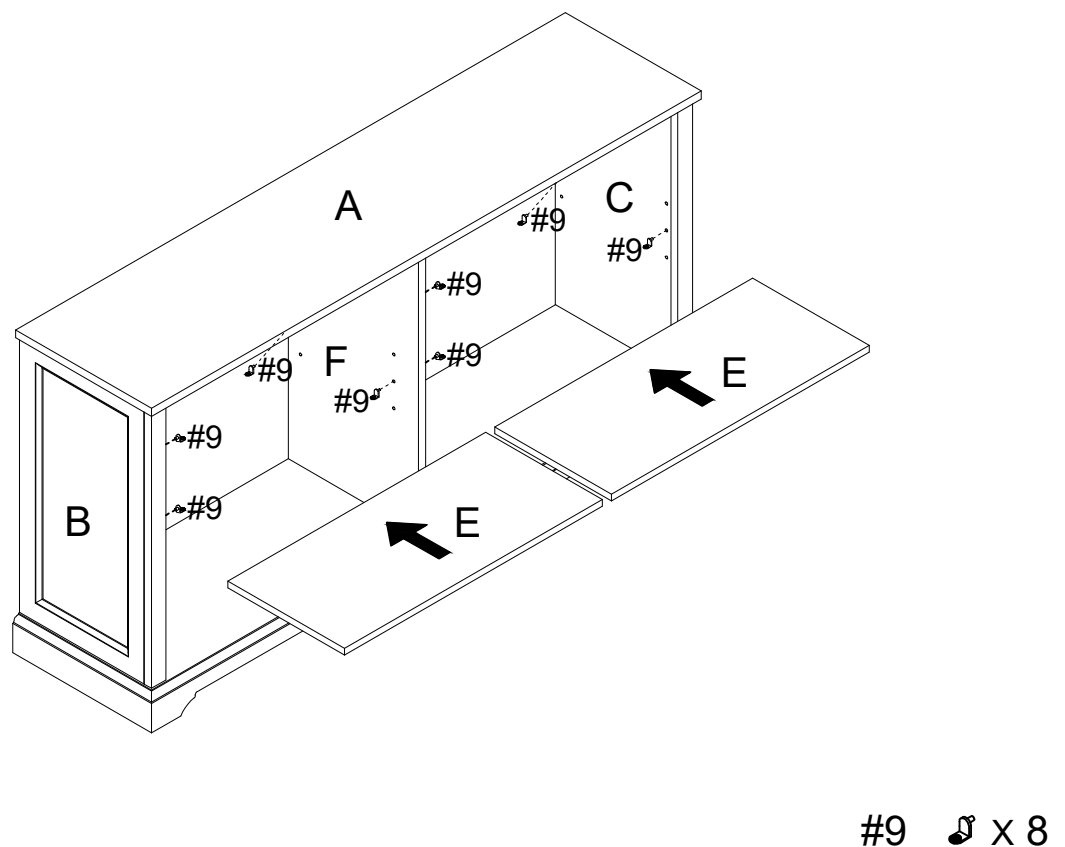





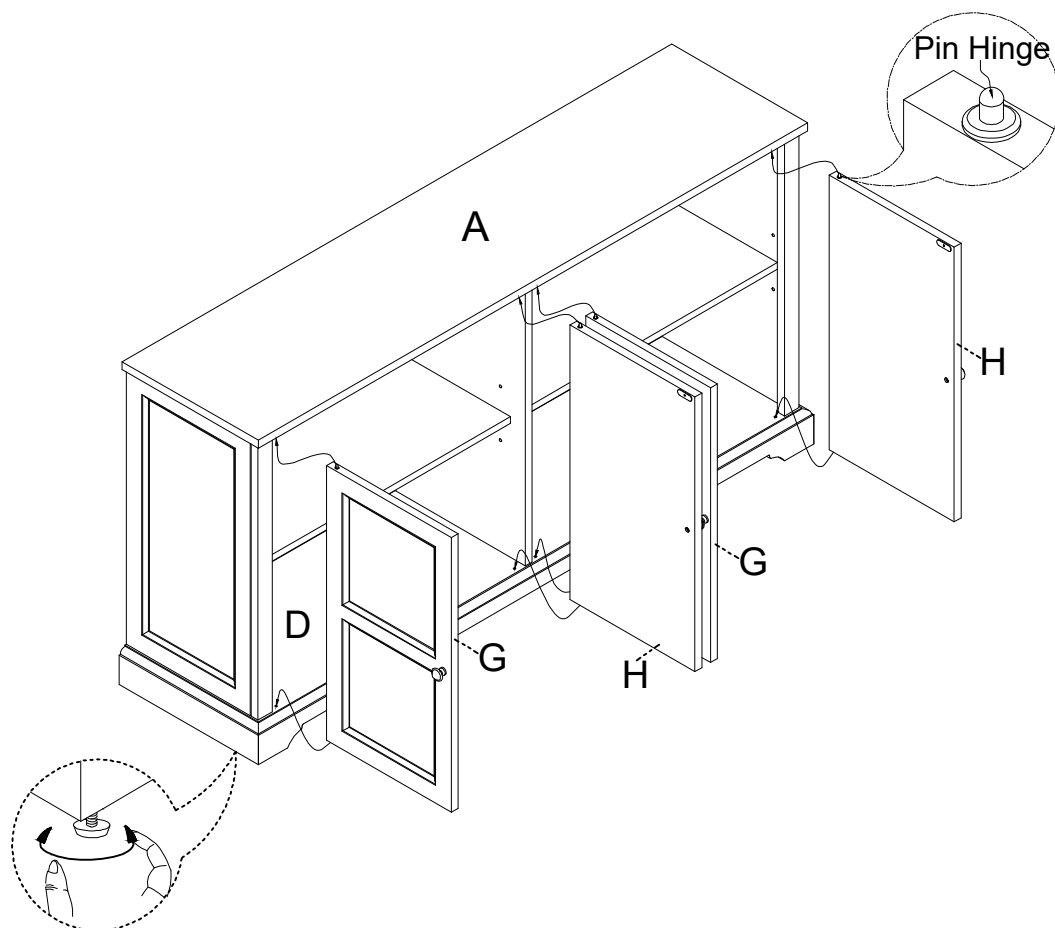

Step 7. Attach doors (parts G & H) by placing bottom pin hinge (pre-installed in door) in the pre-drilled hole of bottom panel (part D). Then depress the top spring-loaded pin hinge so it can be placed in the pre-drilled hole of top panel (part A).

Note: Be sure top and bottom pin hinges are fully extended to secure doors in place.

Note: It is important to adjust levelers once fully assembled and upright. Extend adjustable leveler until it's firmly in contact with the floor. If relocating, adjust leveler as needed until it's firmly in contact with the floor in new location.

Important: Safety strap kit (part #12) must be installed to prevent tipping, damage and/or injury.



#12	A	B	C	D	E
					
Safety Strap Kit 1 SET	Wall Anchor 1 PC	Bracket 2 PCS	Short Screw 1 PC	Long Screw 1 PC	Safety Wall Strap 1 PC

SAFETY WALL STRAP INSTALLATION

Note: It is highly recommended to install this safety strap kit to prevent tipping, damage and/or injury.

1. Insert short screw (C) and safety wall strap (E) through bracket (B) and attach to top panel (part A) using phillips head screwdriver.
2. Drill a 1 1/32" hole where you want to secure the unit. The drilled hole will be at the same height as the hole in top panel (part A) where bracket (B) is attached. Tap wall anchor (A) into the hole.
3. Insert long screw (D) and safety wall strap (E) through bracket (B) into wall anchor (A) using phillips head screwdriver.

Note: This item is not intended for clothing storage use.

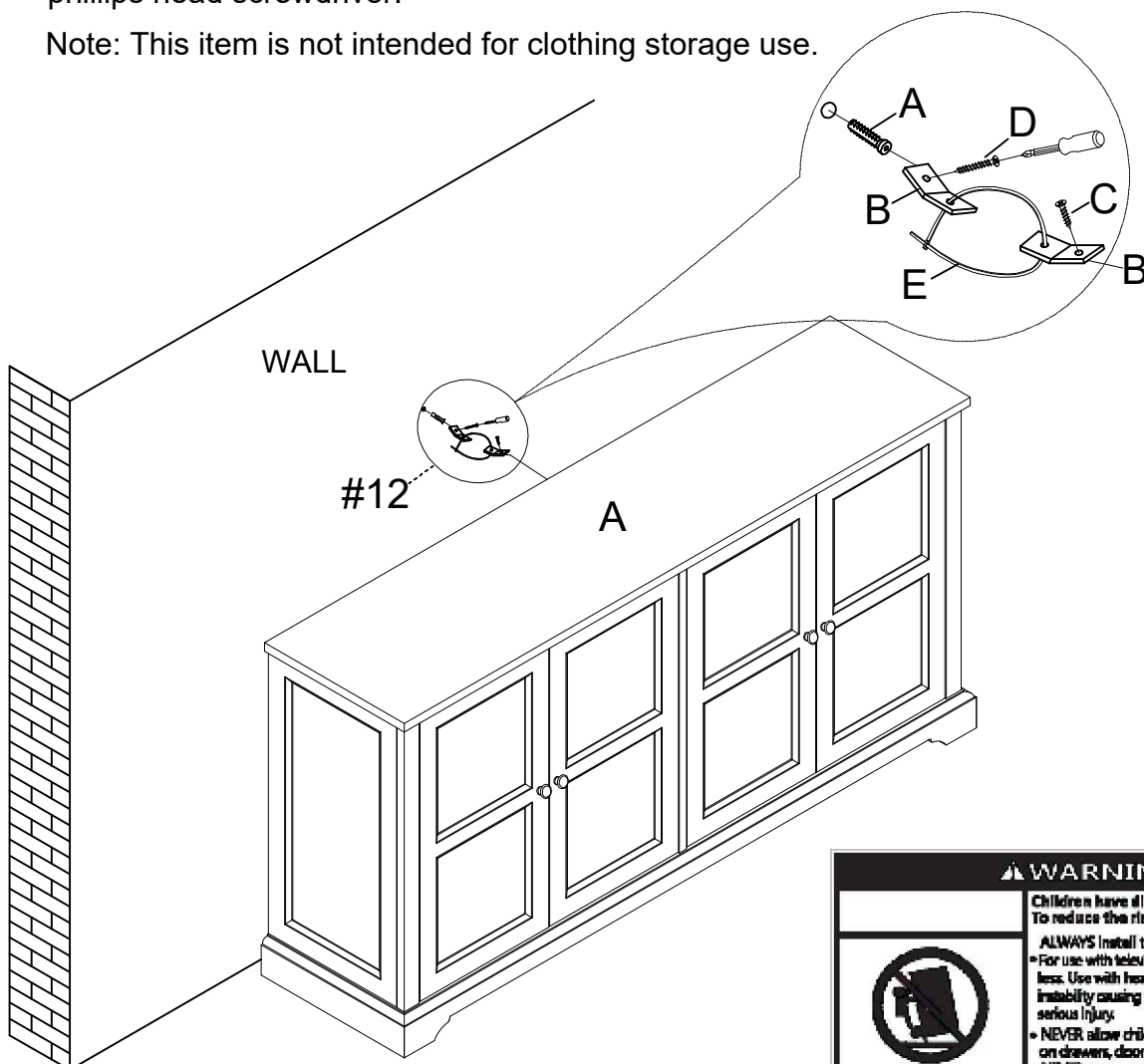

WARNING	
	Children have died from furniture tipover. To reduce the risk of furniture tipover:
	<ul style="list-style-type: none"> • ALWAYS install tipover restraint provided. • For use with televisions weighing 50lbs(23kg) or less. Use with heavier televisions may result in instability causing tip-over resulting in death or serious injury. • NEVER allow children to stand, climb or hang on drawers, doors, or shelves. • NEVER open more than one drawer at a time. Place heaviest items in the lowest drawers. <p>This is a permanent label. Do not remove.</p>