



Deluxe Miter Gauge with 120 Angles



WARNING

For your own safety, read the machine's instruction manual before using any accessory. Failure to heed these warnings may result in serious personal injury and damage to the tool and the accessory.

- Before using the deluxe miter gauge, read and follow all of the provided instructions and safety information.
- Always keep hands clear of the blade, cutter, sanding disc/belt.
- Before making adjustments to the deluxe miter gauge, turn off the power, allow the blade, cutter or sanding disc/belt to come to a complete stop and unplug the machine.
- Always make sure the handle and lock knob are tight before using.
- Before turning on the power after adjustments, verify safe clearance between the protractor and blade, cutter or sanding disc/belt.

NOTE: This miter gauge is designed to work with the POWERTEC 71488 multi T-track fence and POWERTEC 71367 3" fence flip stop (sold separately).

UNPACKING

Refer to Figure 1

Check for shipping damage. Check immediately whether all parts and accessories are included.

ITEM	DESCRIPTION	QTY
A	Deluxe Miter Gauge with 120 angles	1
B	Extra Expansion Discs (Place in a safe place for future use)	4
C	Handle	1
D	Washer	1
E	3 mm Hex Wrench	1
F	2.5 mm Hex Wrench	1

Figure 1

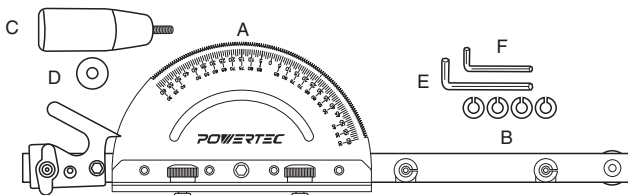

TOOLS NEEDED

No additional tools are needed for assembly.

WARNING

Risk of accidental starting and serious personal injury. Unplug the machine before attaching the deluxe miter gauge.

ASSEMBLY

Refer to Figure 2, 3

1. Loosen the small lock knob and rotate the miter head to move the index lever from the shipping notch into the 0° position.

Figure 2

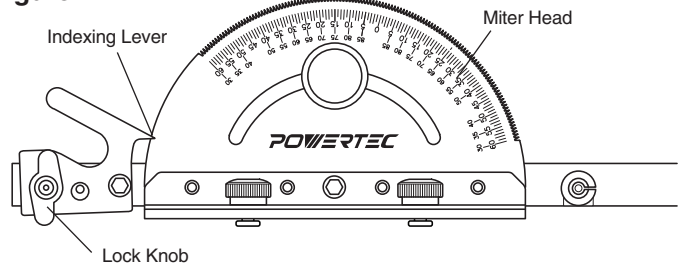

3. Place washer onto handle threads and thread the handle onto the guide bar.
4. Tighten handle and small lock knob.

Figure 3

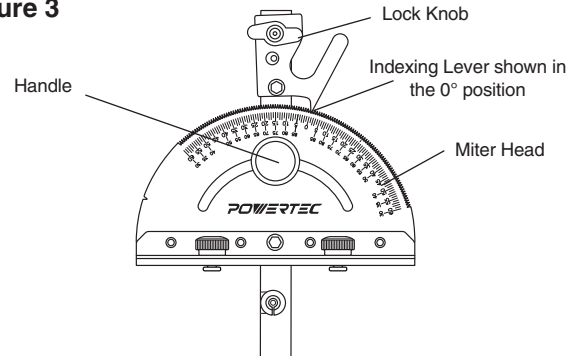

ADJUST MITER GAUGE TO MITER SLOT

Refer to Figure 4, 5, 6

1. Use a square to verify the miter bar is perpendicular to the miter gauge face. The miter gauge is preset at the factory. If not square or requires resetting, see **Setting the Gauge to 90°**.

Figure 4

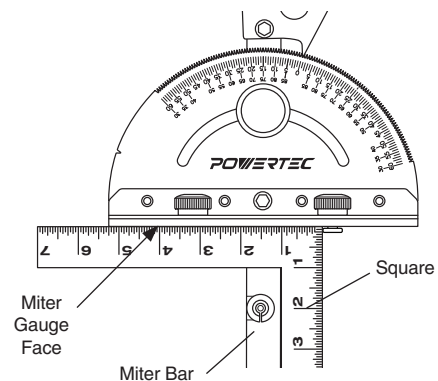

NOTE: The notches are laser cut and are accurate to each other. Once the miter gauge face is square to the bar, no other adjustments are required. If by chance the workpiece is not square, use a square to square the miter gauge face directly to the blade or follow the instructions supplied with the machine to square the machine's miter slot to the blade.

- If the tool is equipped with a T-slotted miter slot, use the included 2.5 mm hex wrench to ensure the screw holding the miter bar plate is tight. If the tool is not equipped with a T-slotted miter slot, remove the plate. Save these parts.

Figure 5

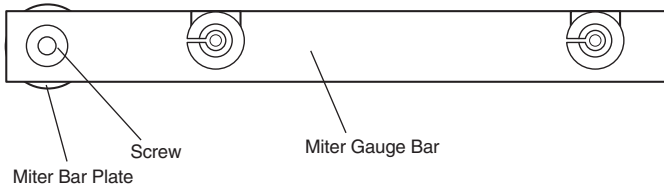

- Place the miter bar into the miter slot and check for side movement. If the miter gauge guide bar moves freely through the miter slot and has no side to side play, no adjustment is needed.

If adjustment is needed:

The four expansion disc located on the top of the miter bar can be adjusted to remove any side movement. Use the 2.5 mm hex wrench to tighten the screws until all side motion is removed. Turn the screws clockwise to tighten the fit and counterclockwise to loosen the fit. Ensure the bar slides freely in the miter slot.

Figure 6

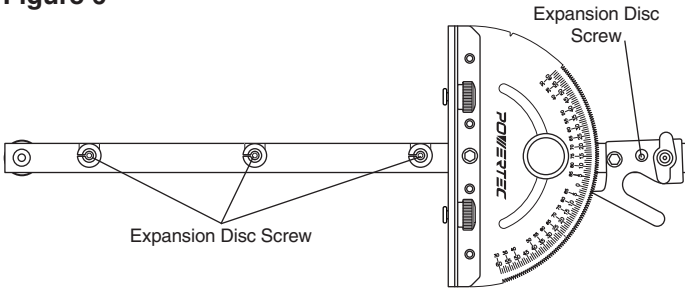

SETTING THE GAUGE TO 90°

Refer to Figure 7

- Loosen the four screws located on the miter gauge face with the 3 mm hex wrench.
- Use a square to set the miter bar and miter gauge face perpendicular.
- While holding the square, tighten the four screws.

Figure 7

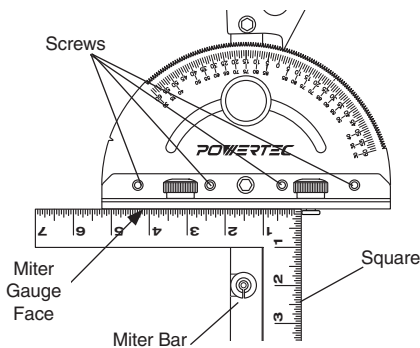

TO USE

Refer to Figure 8

NOTE: A wooden fence can be attached to the miter gauge face if desired.

- Remove the knobs and T-bolts from the miter gauge face and place in a safe place for future use. **NOTE:** These are supplied for use with accessories that accept 5/16" T-bolts.
- The deluxe miter gauge is ready to use.
- Loosen the handle and small lock knob, move the indexing tooth to the desired angle.
- Tighten the small lock knob first and then the handle. Ensure both are tight.

Figure 8

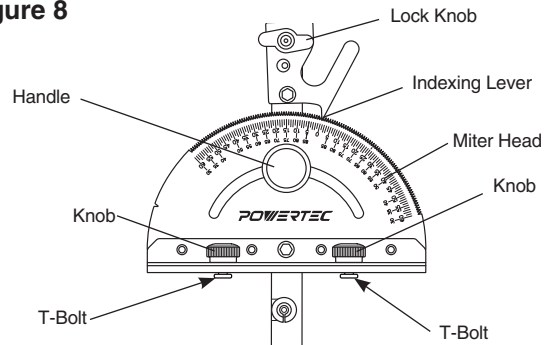

TO INSTALL OPTIONAL FENCE AND FENCE FLIP STOP (SOLD SEPARATELY)

Refer to Figure 9

- Position the fence so the engraved scale reads right to left.
- Loosen the two knobs on the back of the miter face and slide the T-bolts into the appropriate slot of multi track fence.
- Slide fence to the desired position and tighten the two knobs.
- Install the fence flip stop per the instructions supplied with this accessory.

Figure 9

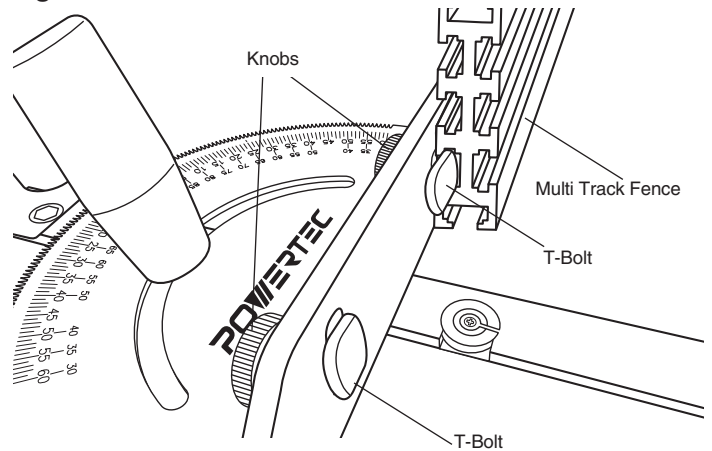

Visit us on the web at www.powertecproducts.com

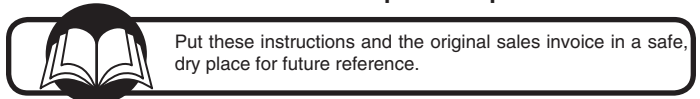

Put these instructions and the original sales invoice in a safe, dry place for future reference.

Southern Technologies, LLC
Waukegan, IL 60087