

# INSTALLATION INSTRUCTIONS

## Building Design and Construction

In order to ensure the anticipated performance and longevity, protect metal panels from potentially corrosive situations and materials. When treated lumber will be in direct contact with metal panels or flashings please note the following: Galvanized steel is compatible with the CCA (Chromated Copper Arsenate) pressure-treated lumber that was predominantly used before 2004, but not with the older Penta treated lumber or the new ACQ (Alkaline Copper Quaternary), CA (Copper Azole), or CBA (Copper Boron Azole). Stainless steel or other special treated fasteners should be used into these non-compatible pressure treated lumbers. Aluminum must be separated from contact with all treated wood since the soluble copper in the preservative is corrosive to aluminum. Likewise, dissimilar metals also require a protective barrier between them to prevent galvanic corrosion. Request FABRAL Technical Bulletins #803, 106, and 107 for more information on treated lumber and dissimilar metals.

**PLASTIC, BUILDERS' FELT, BITUMINOUS PAINT, CAULKING, OR GASKET MATERIAL MAY BE USED TO SEPARATE PANELS FROM TREATED WOOD AND DISSIMILAR METALS.** When using aluminum panels in direct contact with steel, use a separator as described above and fasten with Stainless Steel screws.

Fertilizer, lime, acids, feeds, manure, soils, and many other compounds also cause corrosion in metal panels. Contact between metal panels and any potentially corrosive materials should be prevented.

Porous insulation materials may absorb and retain moisture, and should not be used in direct contact with metal panels. Use a vapor barrier such as polyethylene plastic or 30-lb felt to prevent moisture from contacting both the insulation and the metal panel.

FABRAL's translucent panels are intended for siding applications only. In all situations, foot traffic should be avoided on translucent panels. Translucent panels used in roofing applications will break down in a short time and cause staining and premature corrosion of the metal panels below. If used on roofs, apply butyl caulking to separate the fiberglass panels from the metal. Translucent panels should be cleaned and sealed regularly, as recommended by the translucent panel manufacturer.

## Purlins, Girts and Roof Deck

The substructure to which the metal panels are fastened must be properly spaced and sufficiently thick to provide a roof or wall system able to meet required design loads.

A 2" nominal lumber thickness or 1" nominal thickness are both acceptable purlins. If snow guards are to be installed in the future, a 2 x 8 purlin can be installed in the area for snow guard installation. Call engineering for locations of 2 x 8 purlins. When using purlins, FABRAL recommends a maximum spacing of 24" on-center (note that 5V requires solid decking). Pullout values decrease if the fasteners protrude completely through the purlins. Kiln-dried softwood is recommended for purlins or decking (pine, fir, hemlock, and spruce). Hardwoods are difficult to fasten into without splitting and contain tannic acids that are corrosive to metal panels. Green (non-kiln-dried) lumber may warp, twist, and shrink as the wood seasons fully, causing waviness in the panels as well as loosening and leaking of the fasteners.

Solid decking is highly recommended for all residential applications. When using solid decking or sheathing, always use 30-lb felt or underlayment and plan on using closer fastener spacing and larger diameter #14 screws. (Refer to the tables on page 31).

On re-roofing projects where the condition of the old decking is in question, or where existing shingles will be left in place, new

2x4 or 1x4 purlins should be fastened through the decking and into the rafters. This will provide a solid framework for attaching the metal panels. For more detailed information on re-roofing applications, consult FABRAL Technical Bulletin #721, Re-Roofing With Metal. Load tables are available for all FABRAL panels; contact FABRAL for additional information.

## Roofing

Panel sidelaps should face away from wind driven rain. To accomplish this, begin by installing the first sheet square with the eave and gable at the down wind end of the roof, farthest away from the source of prevailing winds or away from the primary viewing location.

In applications requiring a panel endlap, please refer to the detailed instructions in this booklet. For best results, lap panels as shown and install in the indicated sequence. **ALL ENDLAPS REQUIRE SEALANT. WHEN WEATHER-TIGHTNESS IS CRITICAL, USE SEALANT TAPE IN ALL SIDELAPS.**

To provide a drip edge, allow an overhang of 1 to 2 inches at the eave. At the gable edge, use a gable or sidewall flashing. This will keep weather out, prevent lifting in high winds, and provide a neat, finished appearance. The trim and roofing sheet should be fastened every 12 to 24 inches along the gable edge. Do not step on panel ribs or on trim pieces to prevent kinking.

## Roof Pitch

The metal roofing panels shown in this manual require a minimum slope of 2½" per foot to ensure proper drainage. Refer to the rain-carrying table in this booklet for the maximum allowable panel length per slope that will provide adequate drainage. For longer slopes and lower roof pitches, contact FABRAL for other suitable profiles.

## Bending and Bowing

Aluminum and Steel roofing and siding sheets are rollformed from hardened, tempered metal for maximum strength. If a sheet must be bent, a gentle 90-degree bend is the maximum recommended. Metal should not be re-bent once it has been formed, nor should it be folded back on itself. When a metal roofing sheet must be installed on a curved roof, screws should be installed at every overlapping rib at the sheet ends to resist the natural tendency of the metal to spring back. The standard fastening pattern is permitted over the rest of the sheet. When installing the metal panels shown in this booklet over a curved arch, the minimum radius of the arch is 18' for aluminum panels and 24' for steel panels. Use sealant tape or butyl caulking at all sidelaps and endlaps. Additional care and fasteners must be provided when securing the top and bottom purlins on an arched rafter building to prevent the curved panels from pulling the purlins loose from the rafters. Ring-shank pole barn nails, heavy wood screws, lag screws, or bolts are often used for attaching these purlins.

## Siding

Siding should be installed using the standard fastening and overlap patterns to ensure optimum performance. For strong, neat corners use hemmed corner flashings. **DO NOT RUN SIDING SHEETS ALL THE WAY TO THE GROUND. INSTEAD, PROVIDE A PROTECTIVE BASE OF CONCRETE, MASONRY, TREATED WOOD, OR SIMILAR MATERIAL AND TERMINATE THE SIDING SHEETS 6" ABOVE GRADE.**

If siding sheets are installed horizontally, use sealant tape or butyl caulking at the vertical laps to ensure weather-tight joints. Install panels from the bottom up so that water is directed away from, and not into, the lap joints.

## Fastening

FABRAL can supply either screws or nails for fastening into dimension lumber. Always use screws with solid sheathing. Screws for use with steel panels are galvanized and then coated with an organic polymer for optimum corrosion resistance. For best results with aluminum panels, use #300 series stainless steel screws.

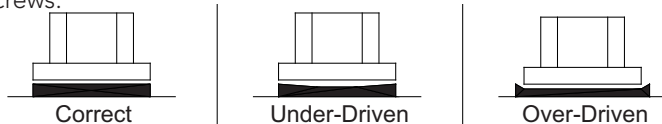

Wood screws with combination metal and neoprene washers should be installed in the flat area of the panel adjacent to the ribs, and tightened such that the washer is compressed as illustrated above. This will ensure a lasting, leak-proof seal. **REMOVE ANY METAL FILINGS CREATED BY THE DRILLING ACTION OF THE SCREWS OR PRE-DRILLING OF THE HOLES TO AVOID RUST STAINING ON THE PANEL SURFACE.** Refer to the fastening schedules in this booklet for the correct fastener locations.

Panels adhered with CondenStop

**FULL LENGTH PANELS FROM EAVE TO RIDGE ARE RECOMMENDED, EAVE OVERHANGS, VALLEYS AND ANY OTHER EDGES EXPOSED TO THE WEATHER SHOULD BE PAINTED TO SEAL MICROFIBERS FROM ABSORBING MOISTURE FROM THE OUTSIDE. WET STACK STORAGE STILL APPLIES TO PANELS WITH CONDENSTOP APPLIED. PLEASE STORE PROPERLY BY COVERING AND TILTING ONE END. IT'S ALWAYS BEST IF THEY CAN BE STORED INSIDE IF NOT BEING IMMEDIATELY INSTALLED.**

## Flashing and Trim

Always begin flashing installation from the bottom and work up, so that upper flashings are lapped on top of lower flashings. This will prevent moisture from leaking under the flashings and into the structure. Endlap flashings a minimum of 6" and seal the lap joints with sealant. Extend flashings 4-6" beyond the building, cut along the bend lines, apply sealant, and fold the side flaps in and the top flaps down to cap off the ends. Secure with pop-rivets or stitch screws.

Some roof conditions, such as valleys, may require a longer endlap and/or a larger flashing to properly drain moisture from the roof. Factors that influence flashing size, shape, and endlap requirements include roof pitch, roof geometry, slope length, and climatic factors (such as heavy snowfall or rainfall).

Whenever possible, begin trim installation at the downwind end of the roof, farthest away from the source of prevailing winds, to allow flashing laps to face away from wind-driven rain. Refer to the details in this book for the proper location of fasteners and sealants.

The flashings and trims shown in this book are standard parts. Custom trims are available to meet your specific design needs. If you need a special trim, please furnish a drawing of the desired shape, including dimensions and angles, to your Fabral dealer to obtain pricing and availability.

Refer to the SMACNA Architectural Sheet Metal Manual for additional information about detailing and installing flashings.

## Safety

Always work safely when installing metal products and use extreme caution on the roof at all times. Wear gloves and safety glasses to reduce the risk of injury, and use hearing protection when operating power tools. Always be sure that ladders are safely positioned and properly secured. Safety harnesses or other special equipment may be required; be sure to Consult OSHA

guidelines for compliance with all safety requirements.

Do Not walk on panels until all the fasteners are installed. Metal roofing panels are slippery when wet, dusty, frosty, or oily -- Do Not attempt to walk on a metal roof under these conditions. Wear soft-soled shoes to improve traction and to minimize damage to the paint finish. Always be aware of your position on the roof relative to any roof openings, roof edges, co-workers, and penetrations. Installing metal panels or flashings on a windy day can be dangerous and should be avoided if possible.

## Cutting Aluminum Panels

To make a cut parallel to the ribs, score the panel deeply with a sharp utility knife and bend back-and-forth along the score, breaking the metal off cleanly. For cuts across the ribs, use straight-cut snips, electric or pneumatic shears, a portable profile shear, or an electric nibbler. Some installers prefer using a circular saw with a metal cutting blade (a fine-tooth hardwood blade, or a standard combination blade reversed in the saw works also). Light oil or soap on the blade will make cutting easier.

## Cutting and Drilling Steel Panels

Steel panels may be cut with metal snips, electric or pneumatic shears, a portable profile shear, or an electric nibbler. Some installers prefer using a circular saw to cut metal panels. Do Not use self-consuming abrasive blades because of the following: 1. Abrasive blades burn the paint and galvanizing at the cut edge, leaving edges that are jagged and unsightly and rust more quickly 2. Abrasive blades produce hot metal filings that embed in the paint and cause rust marks on the face of the panel. If saw cutting cannot be avoided, select a carbide-tipped blade specially designed for cutting light-gage ferrous metal panels. These blades are now available at many home centers and lumber yards. 1. All saw cut panels must be turned face down and cut in a location down-wind and well away from the building and other panels to avoid embedment of metal filings on other panels 2. All saw cut panels must be thoroughly wiped to ensure the removal of all metal filings. Pre-drilling wall panels gives uniform alignment of screw rows. **BE SURE TO REMOVE ANY FILINGS ONCE PANELS ARE INSTALLED TO AVOID RUST MARKS FROM THE FILINGS.**

## Building Maintenance

A metal roof should be inspected annually and cleaned as necessary to maintain its beauty and performance. Any debris or residue, including leaves, twigs, and dust should be cleaned off promptly to prevent moisture entrapment against the metal, which may lead to finish deterioration or premature corrosion. Flashings may need to be re-sealed periodically in order to maintain optimum weathertightness.

## Proper Storage

Store metal panels indoors when possible; if outdoors, cover and elevate. Elevate one side higher for water drainage. Never cover in plastic; use a tarp that can breathe. Allow for air circulation. If a bundle gets wet, break bands and separate sheets; allow sheets to dry completely and only restack if completely dry. Product should be stored for a maximum of 2-4 weeks before being installed.

## Spray Foam Insulation

When insulating metal with spray foam insulation, the first application layer should be getting the insulation behind all framing members. When completing the insulation, ensure the spray foam is installed in 2" thick layers (maximum) until desired thickness is achieved.

# STEEL PANELS

## Grandrib 3®

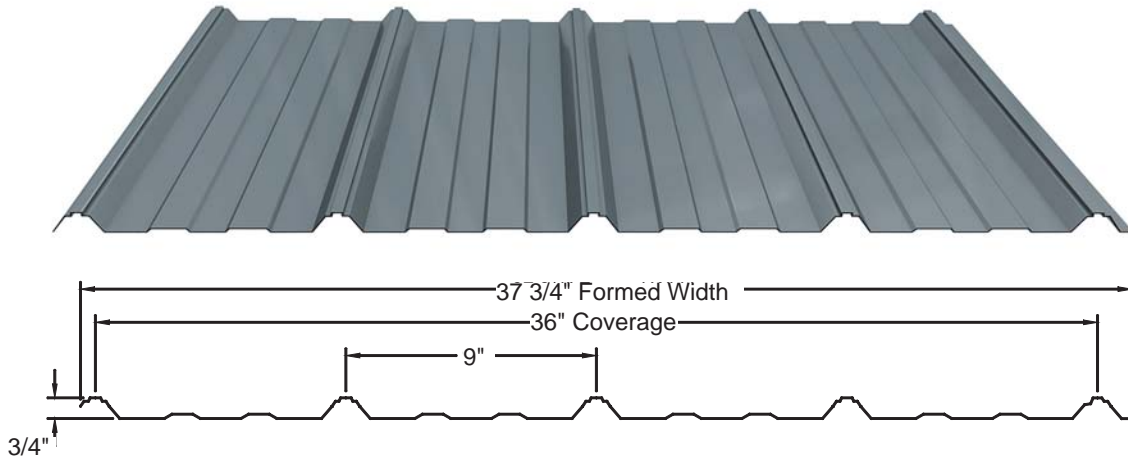

### SCREW PATTERNS

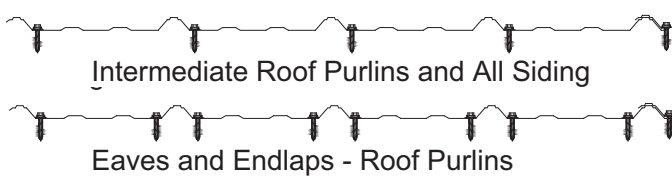

### NAIL PATTERNS

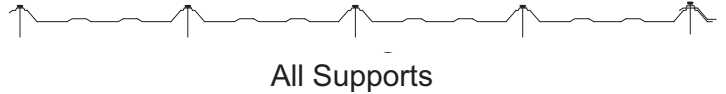

80 screws per square or 1 pound of nails per square  
See page 11 for a load table

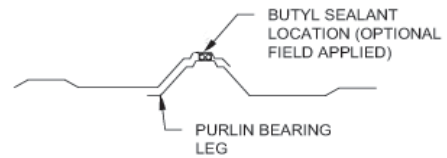

## TrustiRib™

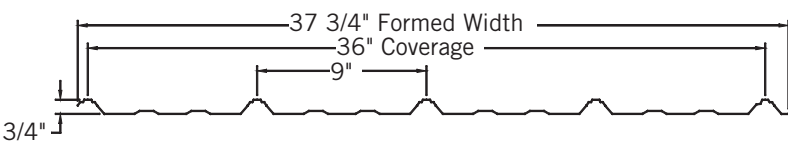
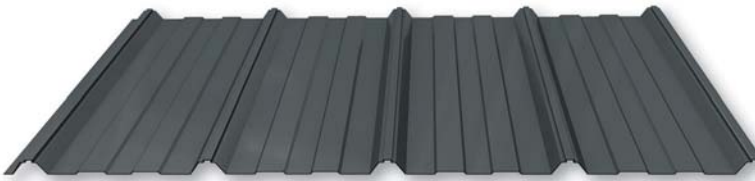

### NAIL PATTERNS

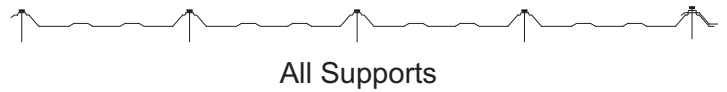

### SCREW PATTERNS

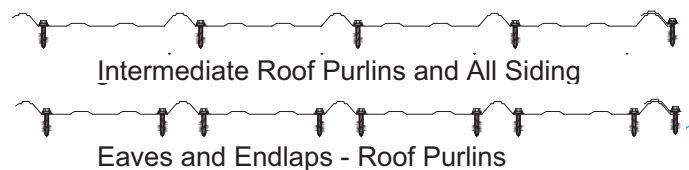

Not all profiles are available in all areas. Please contact Fabral for availability

# STEEL PANELS

## Mighti-Rib®

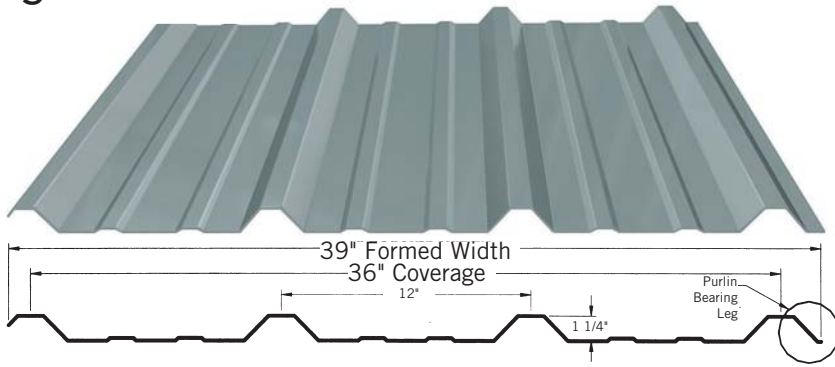

### NAIL PATTERN

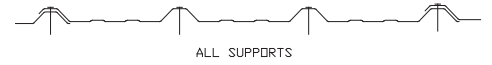

### SCREW PATTERN



Please see Mighti-Rib specific trims on page 20

## 5V Crimp

USE ON SOLID DECKING

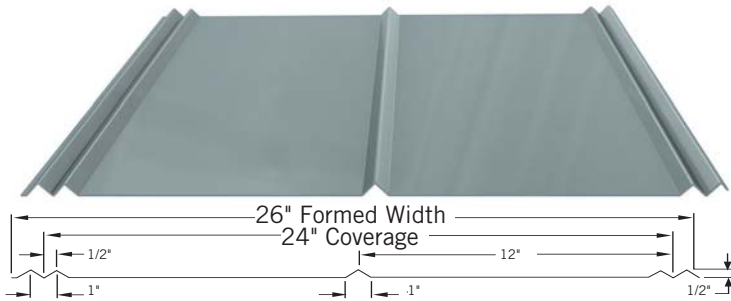

### NAIL PATTERN

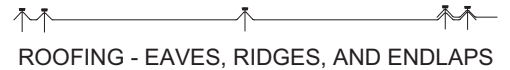

### SCREW PATTERN



## ProClad

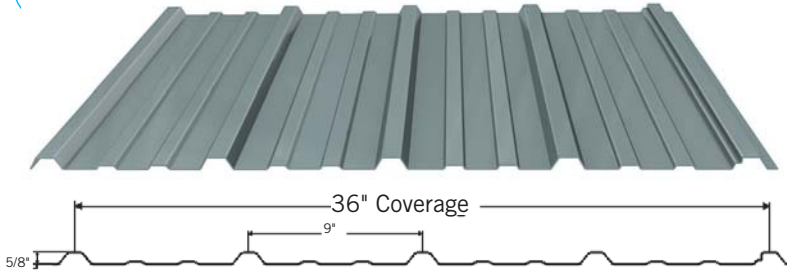

Sidelap Detail



### SCREW PATTERNS

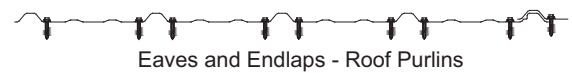

## 1 1/4" Corrugated

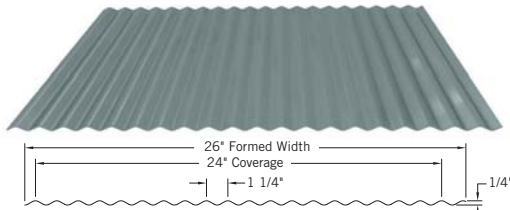

### SCREW PATTERN

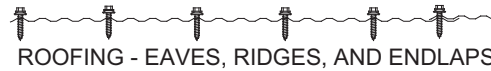

### NAIL PATTERN

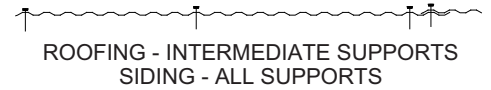
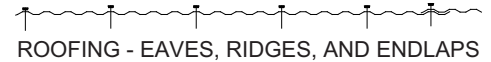

## 2 1/2" Corrugated

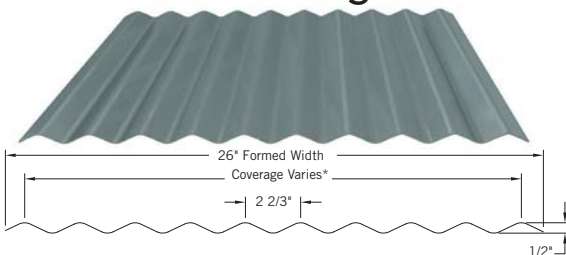

### SCREW PATTERN



### NAIL PATTERN

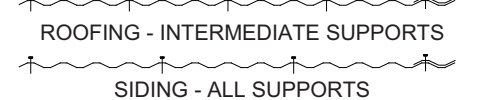
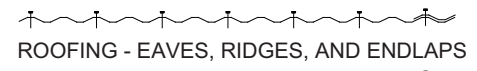

Note: Roofing panels require side caps cover two corrugations.

\* Wall application- 24" coverage with 1 rib overlap Roof application- 21 1/3" coverage with 2 rib overlap

Not all profiles are available in all areas. Please contact Fabral for availability