



30" OSCILLATING WALL MOUNT FAN
MODEL HVWM 30 OSC

30" NON-OSCILLATING WALL MOUNT FAN
MODEL HVWM 30

OWNER'S MANUAL

READ & SAVE THESE INSTRUCTIONS

ASSEMBLY AND OPERATING INSTRUCTIONS

CAUTION: Read and follow all instructions before operating fan. Do not use fan if any part is damaged or missing.

WARNING: To reduce the risk of fire or electrical shock, do not use this fan with any solid state speed control device. This appliance has a 3-prong plug. To reduce the risk of electrical shock, this plug is intended to fit in an outlet only one way. If this plug does not fit the outlet, contact a qualified electrician.

RULES FOR SAFE OPERATION

- Use with grounded 120V, 60 Hz power supply.
- To reduce the risk of personal injury and electric shock, the fan should not be played with or placed where small children can reach it.
- **WARNING:** Always unplug the power cord before servicing, or moving the fan.
- DO NOT use to exhaust hazardous or explosive materials or vapors.
- DO NOT use the fan near a window or door where rain could create an electrical hazard.
- Where possible, avoid the use of extension cords. If they must be used, minimize the risk of overheating by ensuring that they are UL listed. Never use a single extension cord to operate more than one fan.
- Do not operate any fan with a damaged cord or plug or after the fan malfunctions, has been dropped or damaged in any manner.
- Do not insert or allow fingers or foreign objects to enter any ventilation or exhaust opening as it may cause an electric shock or fire, or damage the fan. Do not block or tamper with the fan in any manner while it is in operation.
- Locate the power cord so the fan or other objects are not resting on it. Do not run the power cord under carpeting. Arrange power cord away from room traffic and where it will not be tripped over.
- This fan is not intended for use in wet or damp locations. Never locate a fan where it may fall into a bathtub or other water container.
- DO NOT use this fan outdoors.

INSTALLATION INSTRUCTIONS

NOTE: When selecting the mounting location you should ensure that the wall bracket will be able to mount to a wall stud.

MOUNTING THE WALL BRACKET

1. Locate a wall stud near the selected mounting location and secure the WALL BRACKET to the stud using (4) 5/16"x2" lag screws (NOT INCLUDED).

REAR GUARD AND BLADE ASSEMBLY

1. Attach the SWIVEL ARM to the MOTOR MOUNT FLANGE using the M12 and M6 fasteners.
2. Remove the (4) M5x15 screws and flat washers from the shaft side of the motor.
3. Align the REAR GUARD over the threaded holes in the MOTOR.

- Secure with the (4) M5x15 screws and flat washers that were removed in Step 2.
- Slide the FAN BLADE onto the motor shaft until the front of the FAN BLADE is flush with the shaft end. Use the provided hex wrench to tighten the SET SCREW onto the flat portion of the motor shaft. **Caution:** Do not alter the angle of the blades.

FRONT GUARD ASSEMBLY

- Align front and rear grilles. Slide zip tie through top hole of front grille and top hole of rear grille. Tighten zip tie to secure grilles together.
- Use 7 of the 8 black screws provided to secure front and back grilles together.
- Remove zip tie from top hole of grille assembly. Use remaining black screw to complete grille assembly.

MOUNT FAN TO WALL

- Using assistance, insert the SWIVEL ARM into the WALL BRACKET. Adjust the direction of the fan and secure with the SWIVEL ADJUSTMENT KNOB (horizontal movement) and the M6 screw (vertical movement).

FAN OPERATION

TO ADJUST AIRFLOW UPWARD OR DOWNWARD:

Slightly loosen the M12 and M6 screw at the base of the motor. Tilt motor to desired angle, and firmly retighten the screws.

SPEED CONTROL: Pull chain on motor to set to desired setting: high, medium or low.

OSCILLATION: (Model: HVPF 30 OSCWM only) To oscillate / lock the position of the fan head, pull the OSCILLATING KNOB up to oscillate and down to lock.

CLEANING

WARNING: Unplug from electrical supply source before cleaning. After servicing, any safety device (including grilles and blades) must be reinstalled or remounted as previously installed. Use a soft damp cloth, then wipe with a dry cloth. Do not use harmful cleaners. Do not bend blades.

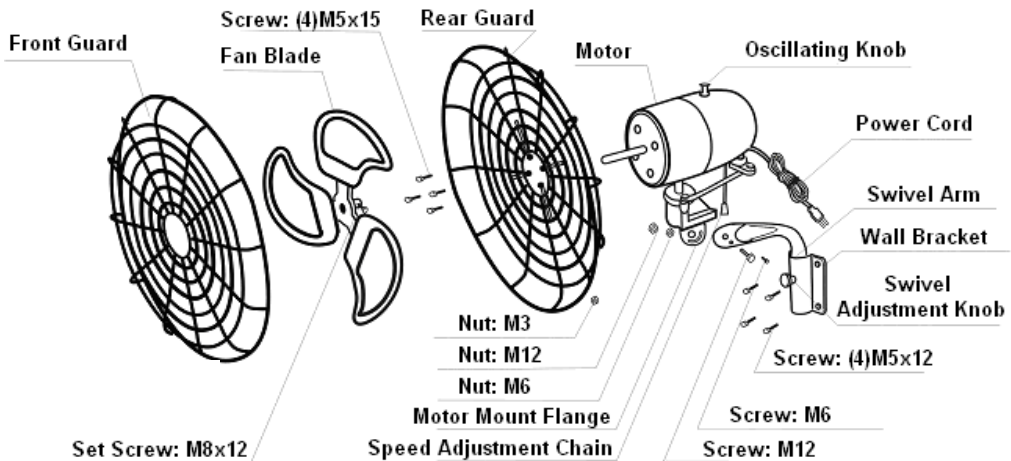

LIMITED WARRANTY

This warranty is underwritten by Falco Insurance Company and is extended to the original retail purchaser of this model or, if this unit is purchased and requires installation by a building contractor, to the original owner of the home. No subsequent purchaser of the unit or of a home in which it is installed is entitled to any of the benefits of this warranty.

This product is warranted against defects in materials and workmanship for a period of two (2) years from the date of original retail purchase. No other parts or components are warranted. There is no warranty for defects caused by abuse, faulty installation, or the like.

Repairs or replacement parts supplied under this warranty are warranted only for the period of this warranty; that is, two (2) years from the date of the original retail purchase of the unit. In the event of a defect or malfunction, we will replace or repair the defective part or component only and return the new or repaired part to you freight prepaid.

You must bear all other expenses incurred in obtaining repairs, including labor required for field repair or replacement, and the cost of shipping the defective part to us. You must also bear the cost of repair to or replacement of any part or component and the shipping charges incurred for the repair or replacement and return to you of any part or component not covered by this warranty, including parts or components damaged by you.

The company reserves the right to demand and receive written evidence of the date of purchase before undertaking its obligations under this warranty. The right to demand and receive written evidence of date of purchase extends to all licensed dealers of Ventamatic, Ltd. products.

You should, therefore, retain your sales slip and attach a copy of it to the warranty claim.

To start a warranty claim you must:
Contact Ventamatic, Ltd.

An RGA (Returned Goods Authorization) form is required for returns to the factory to ensure your return can be processed efficiently and quickly. Please contact Ventamatic, Ltd. toll-free at 800-433-1626 or via web at www.MYMAXXAIR.com to obtain an RGA and follow the instructions given.

There is no informal dispute settling mechanism available in the event of a controversy involving this warranty.

Any and all implied warranties which may exist terminate upon the expiration of this warranty two (2) years from the date of the original retail purchase. Some states do not allow limitations on how long an implied warranty lasts, so this limitation may not apply to you.

Ventamatic, Ltd. is not liable to you for incidental or consequential damages arising out of defect or malfunction of a unit or its installation or out of any alleged breach of this warranty. Some states do not allow the exclusion or limitation of incidental or consequential damages, so this limitation may not apply to you.

This warranty gives you specific legal rights and you may also have other rights which may vary from state to state.