

INSTRUCTIONS FOR MODELS

CPV-T
CPV-T-DV

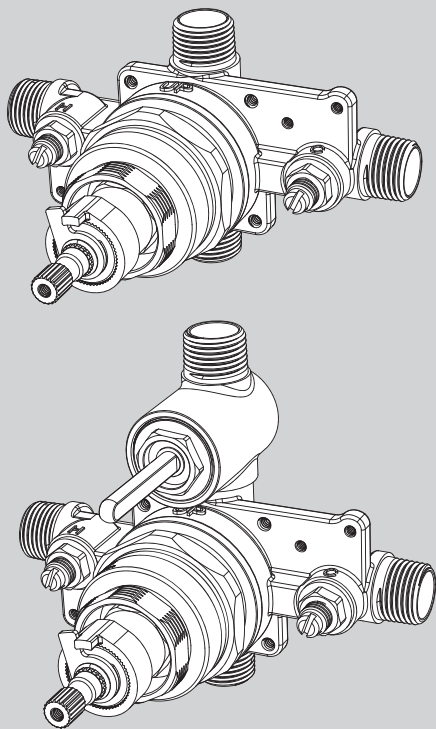

NEED HELP?

For additional assistance or service please contact:

SPEAKMAN® Company
400 Anchor Mill Road
New Castle, DE 19720

800-537-2107

customerservice@speakman.com

www.speakman.com

92-CPV-T-02

TOOLS AND SUPPLIES

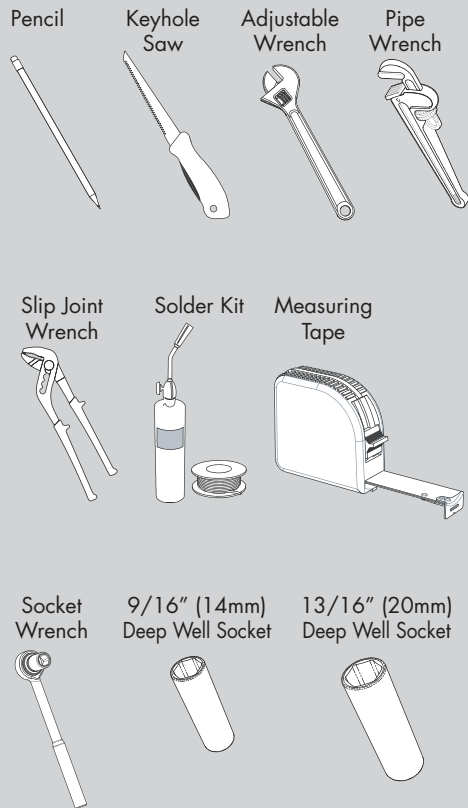

HELPFUL TOOLS & SUPPLIES:

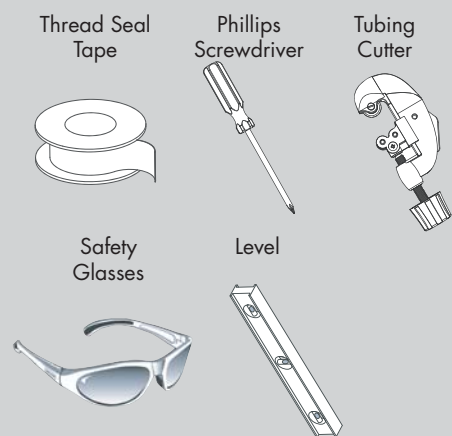

IMPORTANT

- Be sure to read instructions thoroughly before beginning installation.
- Be sure to have properly adjusted the Temperature Limiting Stop (TLS) as outlined in this Installation Manual.
- Inspect all connections after installation of valve.
- This valve has an operating range of 20-80 psi.
- This valve is designed to be used in conjunction with a shower-head rated at 1.5 gpm (5.7 L/min) or higher flow rate.
- **NOTE:** This installation manual covers several models of valves. While the appearance of your valve may differ from those shown, the installation method is the same.
- Maximum water pressure: 125 psi static; minimum water pressure: 20 psi flowing; minimum cold supply temperature: 40 °F; maximum hot supply temperature: 160 °F; minimum hot supply temperature: 5 °F above set point.

SAFETY TIPS

Cover your drain to prevent loss of parts. Be sure to wear eye protection while cutting pipe.

MAINTENANCE

Your new Shower/Bath Valve is designed for years of trouble-free performance. Keep it looking new by cleaning it periodically with a soft cloth. The use of harsh chemicals and abrasives on any of the Speakman custom finish products may damage the finish and void the product warranty. Please be sure to only use approved cleaners. Please contact Speakman for any clarification of acceptable cleaners.

This type of valve must be cleaned and maintained on a regular basis. Periodic maintenance should be performed at least every 12 months or after any changes have been made to the building's plumbing system. This maintenance should include removing and cleaning the spring check stop components. Make sure the stop poppet in each stop moves freely. Valves that are installed outdoors should be winterized by removing all of the internal parts and removing any standing water from the valve. Quarterly the maximum hot temperature setting (TLS) should be checked and adjusted accordingly.

WARRANTY

Additional warranty information can be found at: www.speakman.com

- 1 Referencing the supplied rough-in dimensions (located at the end of this manual), determine the preferred location of valve. Align the supplied Rough-In Template with this location and trace outline of template onto wall.

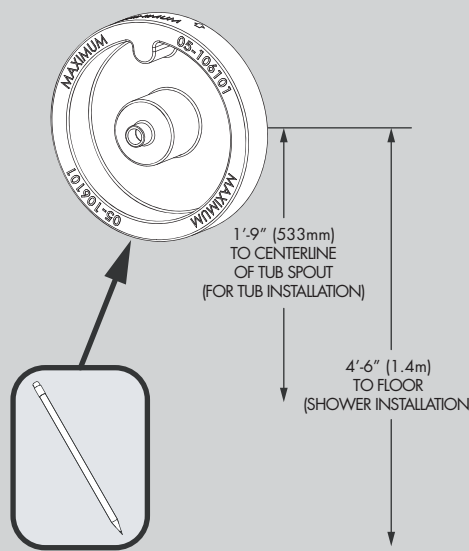

- 2 Using a Keyhole Saw or similar tool, cut along traced line and remove this section of wall.

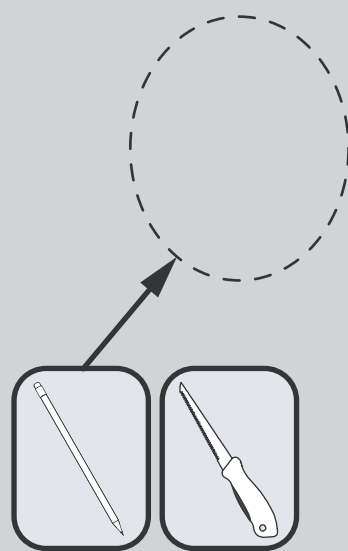

- 3 Shut off the water supply to the Tub and Shower. Verify that the hole sizes and positions in the wall are correct:

- A. The shower and tub spout outlet holes should be 1" diameter.
- B. To determine the Valve mounting depth, see **STEP 4**.
- C. The recommended Valve depth to the finished wall is 2½" minimum to 3½" maximum. Position the Valve Body 1 correctly in the wall with the "UP" pointing up. The 1'-9" minimum from the Valve Body to the Tub Spout is required for proper operation.

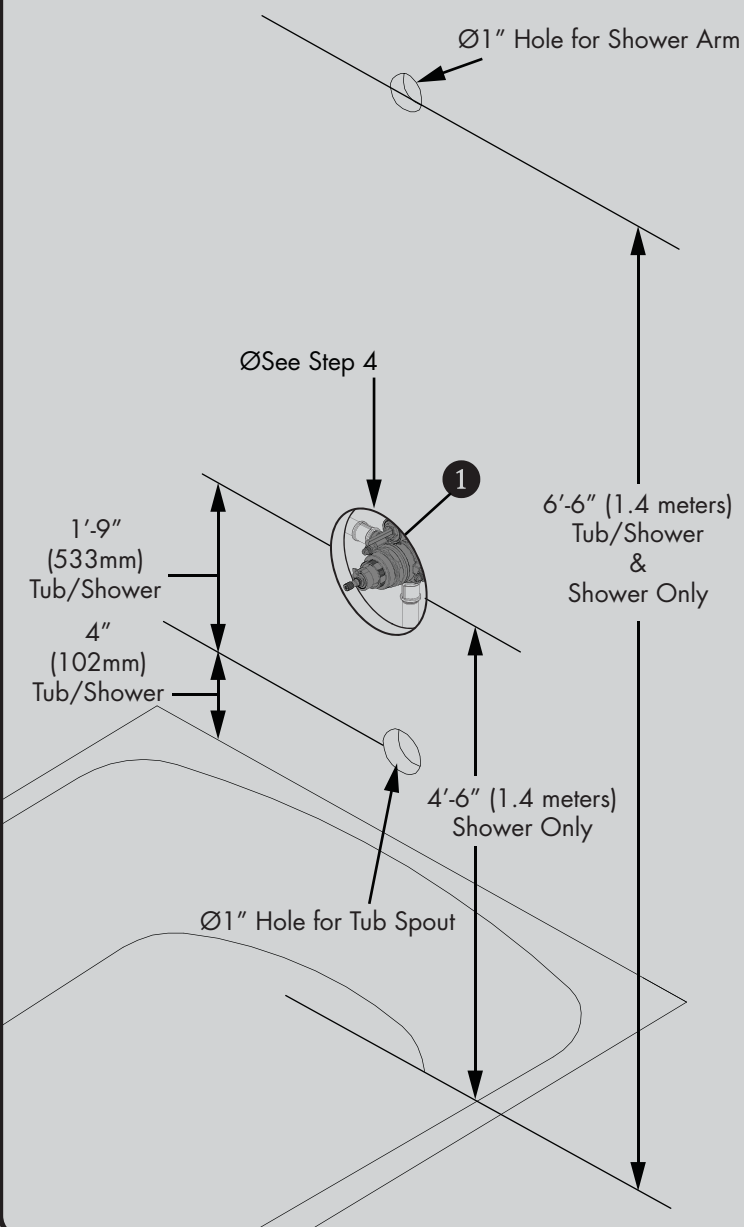

- 4 Install the Rough-In Template over the Shower Valve being sure the Rough-In Template sits flush against the Valve. Following the rough-in dimensions for your model of valve (located at the end of this manual) as well as the markings on the supplied Rough-In Template, install valve at proper depth. The distance from the centerline of the inlet/outlet ports of the Valve Assembly to the finished wall **MUST** be between 2½" - 3½". See images below for reference.

MINIMUM MOUNTING DEPTH

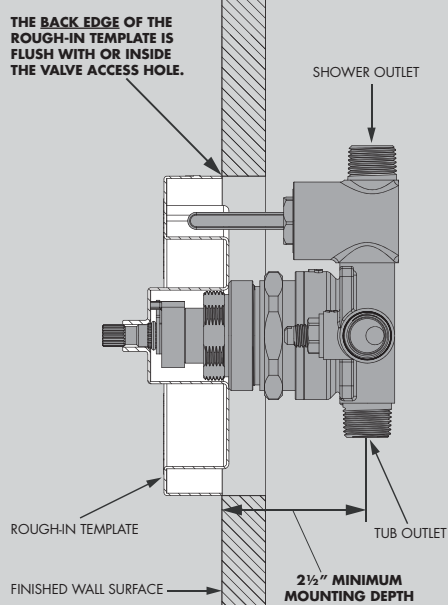

MAXIMUM MOUNTING DEPTH

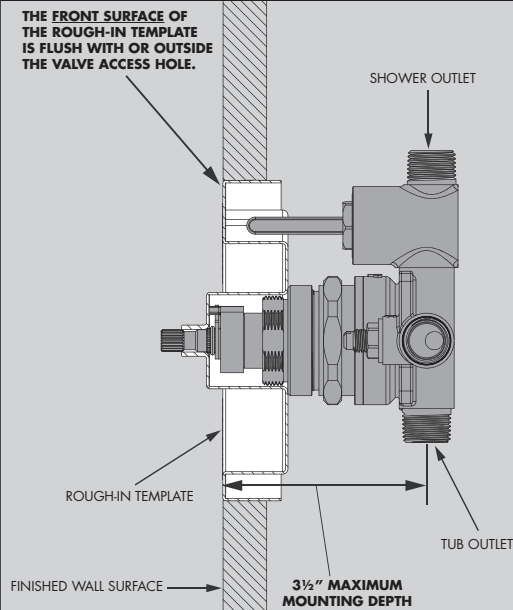

- 5 If your installation is for a shower only, apply Thread Seal Tape in a clockwise direction to the Tub Outlet Port 1 and install the included Plug Cap. Wrench tighten. If you are performing a pipe fitting installation, apply Thread Seal Tape around all pipe threads in a clockwise direction.

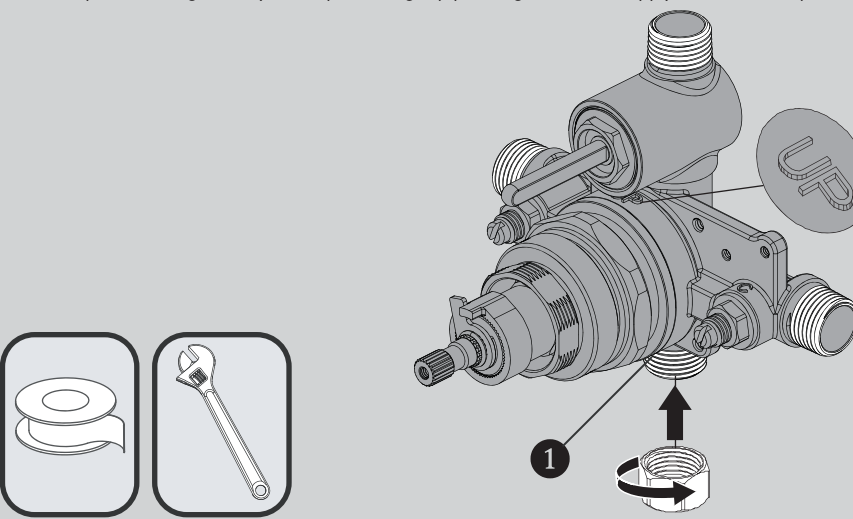

6 PIPE FITTING INSTALLATION

Connect the HOT and COLD Water Supply Lines **2** (not included), the Shower Outlet Pipe **3** (not included), and Tub Outlet Pipe **4** (not included), by threading them into the Valve Body **1** in a clockwise direction. Tighten the pipes to the Valve Body **1** with a Pipe Wrench. Connect the Pipe Elbows **5** (not included), to the end of the shower outlet and tub outlet pipes. If performing a shower only installation, install Plug Cap **6** in place of tub outlet piping, as shown in **STEP 5**.

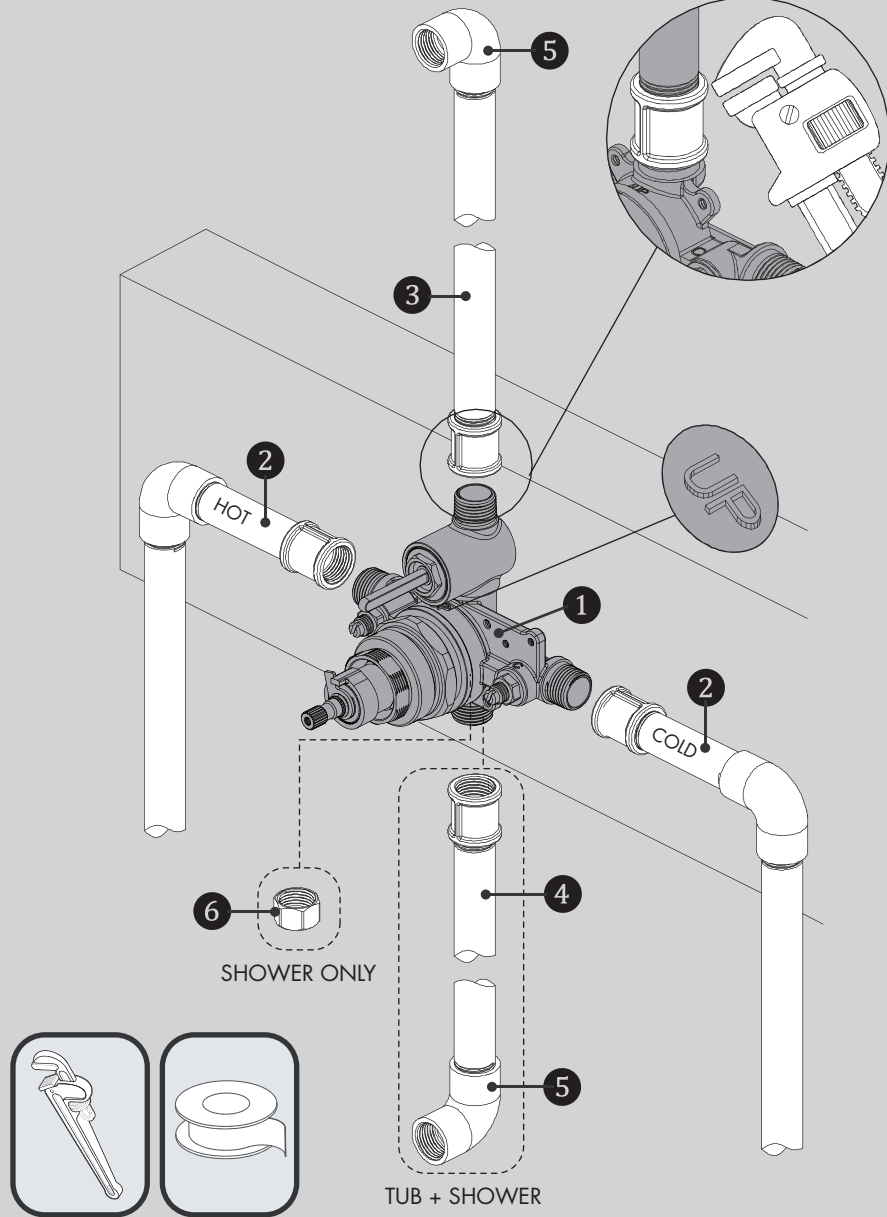

NOTE: The HOT water supply lines go into the H inlet, and the COLD water supply lines go into the C inlet. Do not use PEX or CPVC between the valve and spout.

7 COPPER SWEAT INSTALLATION

When performing a Copper Sweat installation, it is recommended that you remove the Valve Cartridge **4**, Integral Stops **5**, and Diverter Cartridge **2** (where applicable) to prevent damage during soldering. Use a Slip Joint Wrench to unthread and remove the Retaining Nut **3**. Then remove Valve Cartridge **4**, from Valve Body **6**. Unthread and remove the Integral Stops **5** using a Socket Wrench equipped with a 9/16" (14mm) Deep Well Socket. If your Shower Valve is equipped with an Integral Diverter, remove the Diverter Retaining Nut **1** using a Socket Wrench equipped with a 13/16" (20mm) Deep Well Socket. Remove Diverter Cartridge **2** to prevent damage during soldering.

After soldering (**STEP 8**) is completed, reinstall the Valve Cartridge **4**, making sure that the mounting posts are aligned and engaged to the corresponding holes in the Valve Body **6**, with the "H" marking to the left side as shown below. Slide Retaining Nut **3** over the Valve Cartridge **4** and thread onto the Valve Body **6**. Tighten securely with Slip Joint Wrench on the machined flats of the Retaining Nut **3**. Final torque should be 62-80 in*lb. Take care to not over tighten connection or damage may occur. Reinstall the Integral Stops **5** using a Socket Wrench equipped with a 9/16" (14mm) Deep Well Socket. Final torque should be 70-106 in*lb. If your Shower Valve is equipped with an Integral Diverter, reinstall the Diverter Cartridge **2** taking care to align mounting posts of Cartridge with the corresponding holes in the Diverter Valve Body. Install Diverter Retaining Nut **1** and tighten with a Socket Wrench equipped with a 13/16" (20mm) Deep Well Socket. Final torque should be 35-53 in*lb. Take care to not over-tighten connections.

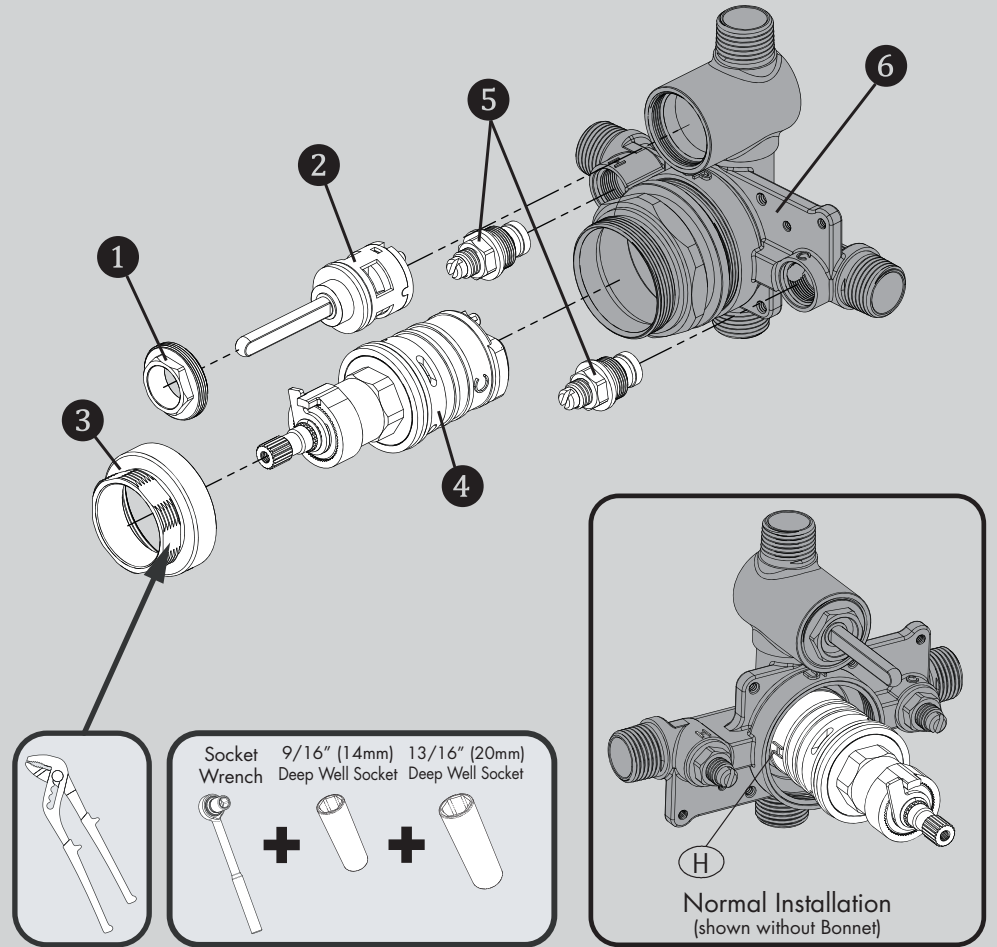

NOTE: Never install the valve body upside down!

8 COPPER SWEAT FITTING INSTALLATION

Connect the HOT and COLD Water Supply Lines **2** (not included), the Shower Outlet Pipe **3** (not included), and Tub Outlet Pipe **4** (not included), by soldering them into the Valve Body **1**. Connect the Pipe Elbows **5** (not included), to the end of the shower outlet and tub outlet pipes. If performing a shower only installation, install Plug Cap **6** in place of tub outlet piping, as shown in **STEP 5**. Verify that all connections are soldered. Reassemble Valve components as outlined in **STEP 7**.

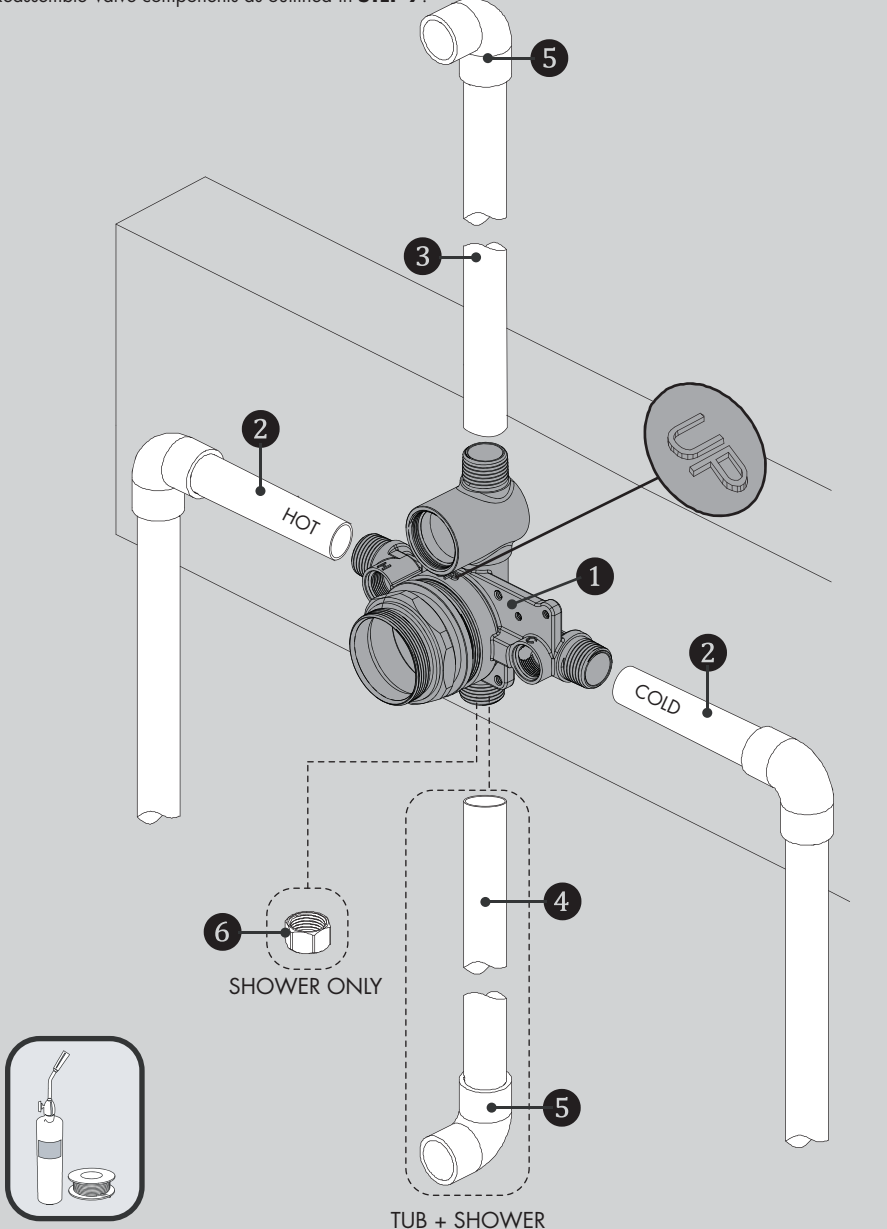

NOTE: The HOT water supply lines go into the H inlet, and the COLD water supply lines go into the C inlet. Do not use PEX or CPVC between the valve and spout.

9 BACK-TO-BACK INSTALLATION

Your Shower Valve has the ability to be mounted back-to-back with another Valve in a shared space. This means the HOT and COLD inlets may be reversed. Please see the following steps to adapt your valve for back-to-back mounting or reversed inlet supplies.

If you are **NOT** making a reverse or back-to-back installation, skip this step, and continue with **STEP 10**. If the HOT and COLD water supplies are reversed (HOT on right and COLD on left), disassemble Valve Cartridge as outlined in **STEP 7**. Rotate Valve Cartridge **2** 180° so "H" appears on the right. Install the Valve Cartridge **2** making sure that the mounting posts are aligned and engaged to the corresponding holes in the Valve Body **3**. Slide Retaining Nut **1** over the Cartridge and thread onto the body. Tighten securely with Slip Joint Wrench on the machined flats of the Retaining Nut **1**. Final torque should be 62-80 in*lb. Take care to not over tighten connection or damage may occur.

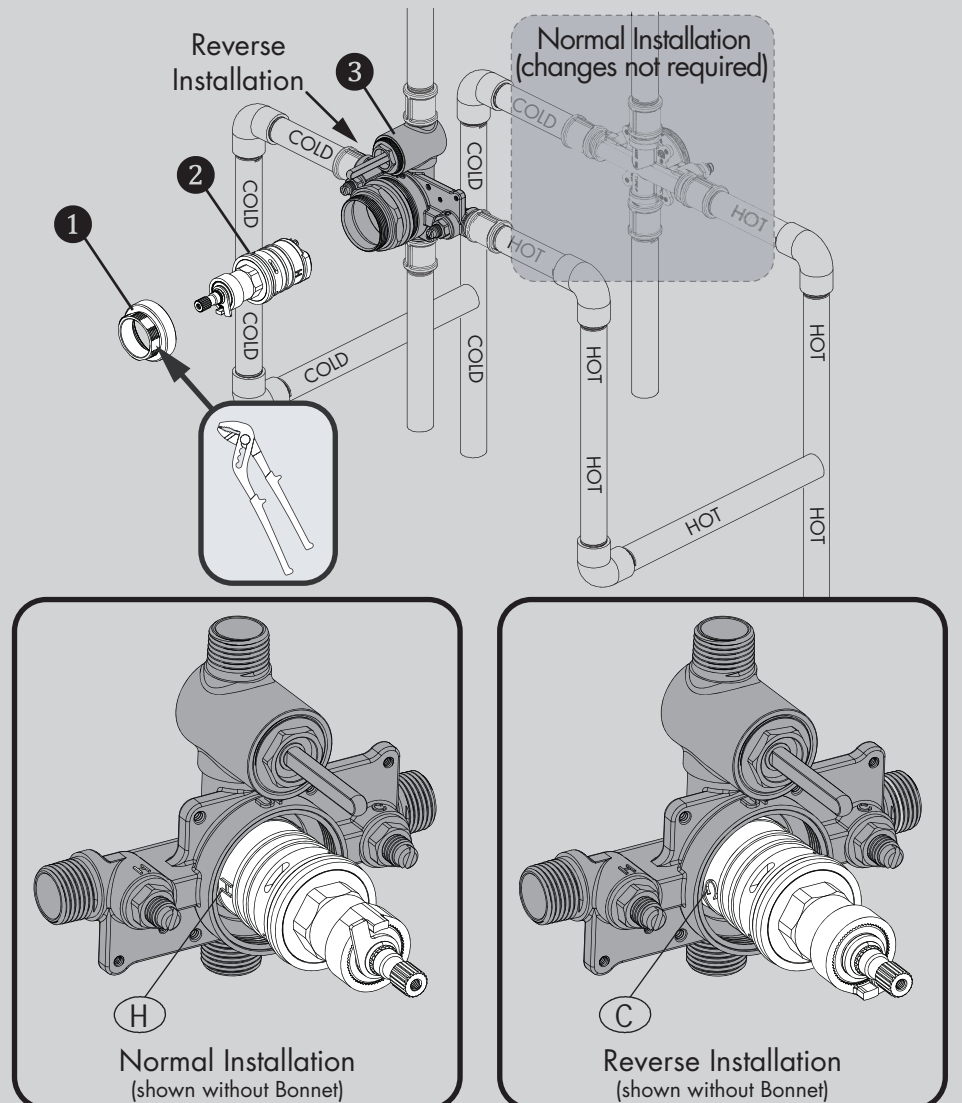

NOTE: Never install the valve body upside down!

10 FLUSHING THE WATER OUTLETS AND CHECKING FOR LEAKS

Place the Handle ① on the Valve Cartridge Spindle ② and turn the Handle ① clockwise to the full on mixed position. Turn on the HOT and COLD water supply lines and allow the water to flow from the outlets for one minute, or until all foreign matter has been flushed out. Check for leaks. Shut off the water at the Valve and supply lines. Remove the Handle ①.

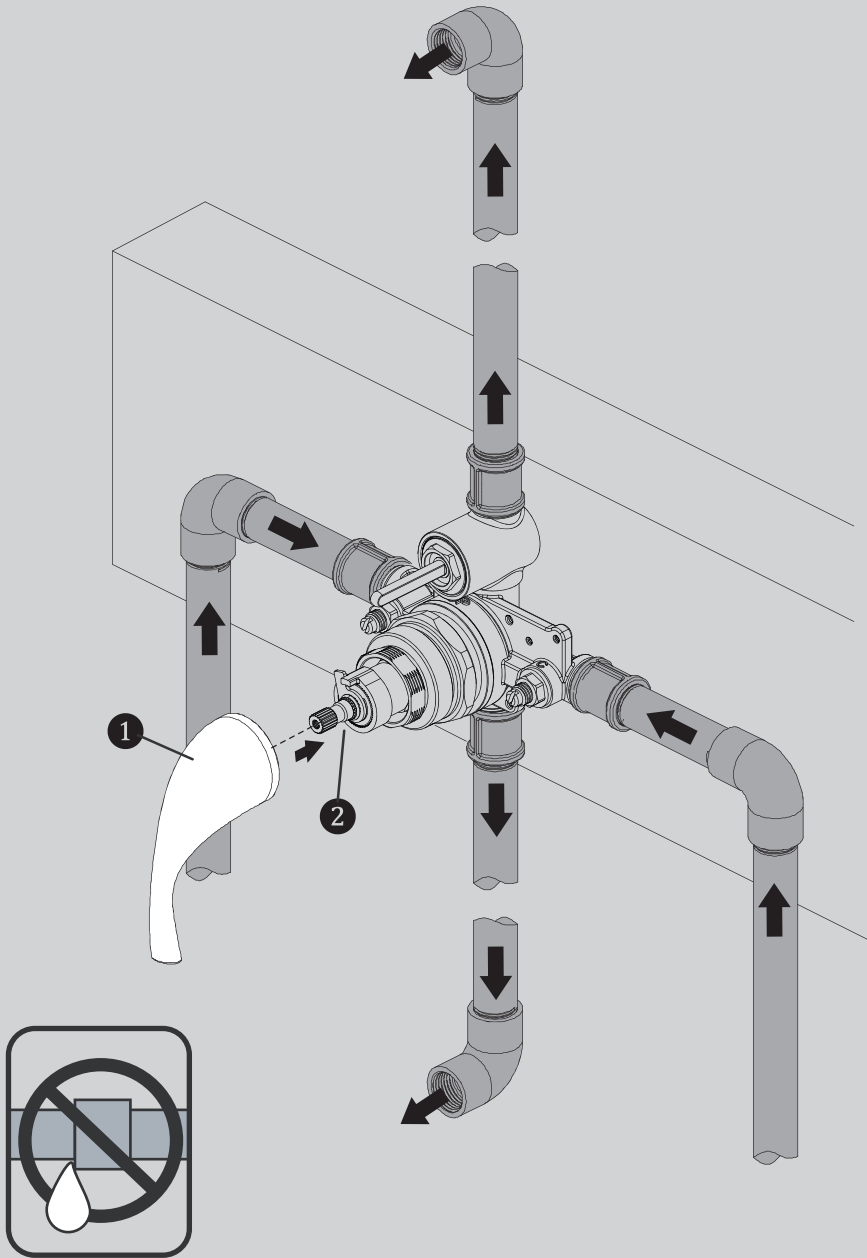

11 TEMPERATURE LIMIT ADJUSTMENT

The maximum outlet temperature setting adjustment (Temperature Limit Stop (TLS)) of the Valve has been factory set at 110 °F. To adjust the limit of the maximum outlet temperature the Valve delivers, adjust the Valve's temperature limit stop (TLS) plate by following the steps below.

- Slip the retaining O-ring and the TLS plate towards the end of the spindle.
- With the water supplies "On", rotate the valve spindle clockwise to the maximum desired outlet temperature.
- Position the TLS plate so it contacts the Lug and therefore restricts the clockwise rotation of the spindle.
- Slip the retaining O-ring back into the groove of the spindle to hold the TLS plate in place.
- Once desired outlet temperature is achieved, rotate the spindle counter-clockwise to the "Off" position.

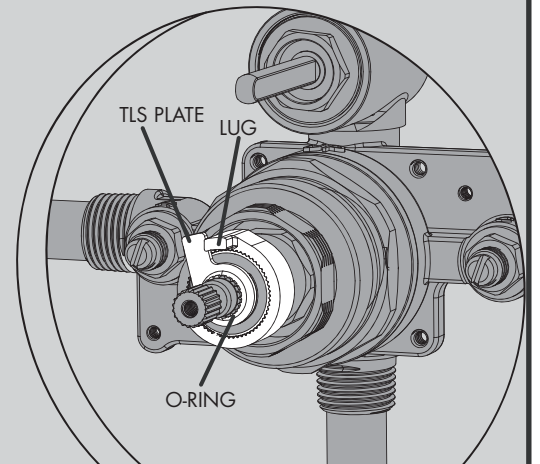

NOTE: A thermometer can be held at the Valve outlet to aid in either checking the existing factory setting or reaching the desired outlet temperature.

12 Reinstall Rough-In Template over Valve to protect it during final wall preparation.

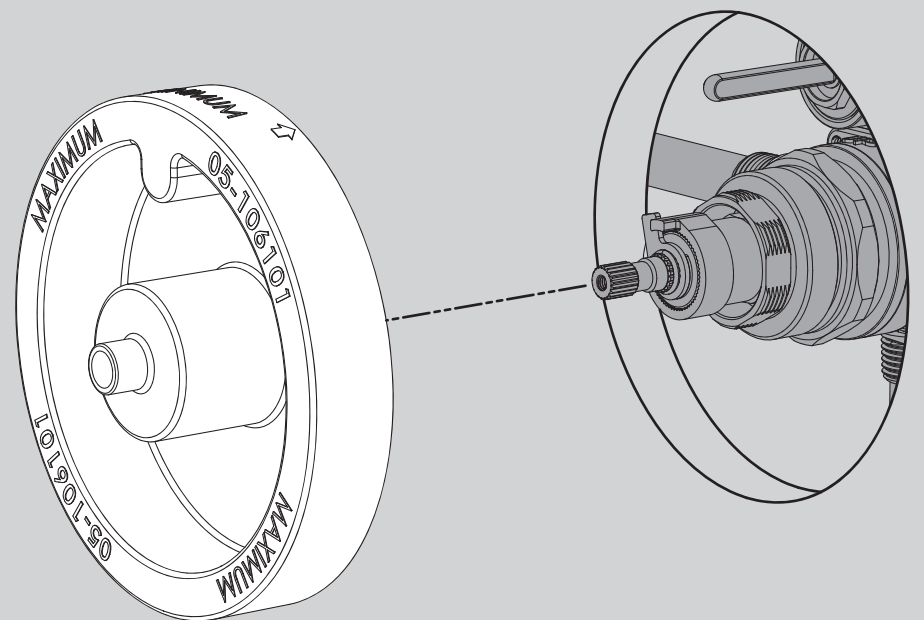

CPV-T / CPV-T-DV SERVICE INSTRUCTIONS

Service Instructions

Caution- Any repair or servicing of the Valve may effect the maximum outlet temperature setting of the Valve. After working on the Valve, make sure the maximum outlet temperature is set to the recommended setting of 110 °F.

Thermostatic Cartridge Removal

- 1) Remove Trim from Valve. Close the Integral Stops of the Valve by turning the Stop Spindles clockwise.
- 2) With the valve in the "OFF" position, remove the Retaining Nut by unthreading with a Slip Joint Wrench.
- 3) If necessary, remove the Cartridge from the Valve Body by pulling on the Valve spindle of the Cartridge. Verify that the Lower Cartridge Seals are in place within the Valve Cartridge, and not within the Valve Body. Inspect Lower Cartridge Seals with Integral Screens to verify they are debris free. If debris is present, remove Lower Cartridge Seals and clean Screen material.
- 4) Replace the Thermostatic Cartridge if necessary. When replacing the Thermostatic Cartridge, verify that the Lower Cartridge Seals are properly installed in the recesses on the bottom of the Cartridge. These Lower Cartridge Seals are positioned over the HOT & COLD inlet waterways of the Valve Body.
- 5) Reassemble the Retaining Nut by threading it into the Valve Body with a Slip Joint Wrench. Final torque should be 62-80 in*lb. **Important-** Adjust the Valve's maximum outlet temperature to the recommended setting of 110 °F. See Temperature Limit Stop adjustment steps within this document.
- 6) Open the Integral Stops of the Valve by turning the Stop Spindles counter-clockwise. Check Valve for leaks.
- 7) Reassemble the Trim parts.

Spring Check Stop Parts Removal

- 1) Remove Trim from Valve. Shut off HOT and COLD water supply lines to the inlets of the Valve.
- 2) Unscrew the Stop's Retaining Nut using a Socket Wrench equipped with a 9/16" (14mm) Deep Well Socket. Carefully remove the Retaining Nut w/Spindle, Spring, and Poppet assembly. Clean and/or replace the necessary parts. Reassemble the parts, reversing the above procedure. Final torque should be 70-106 in*lb. Repeat procedure on the other Stop.
- 3) Turn on the HOT and COLD water supply lines. Check for leaks.
- 4) Reassemble the Trim Parts.

Diverter Cartridge Removal (if present)

- 1) Remove Trim from Valve. Close the Integral Stops of the Valve by turning the Stop Spindles clockwise.
- 2) Remove the Diverter Retaining Nut using a Socket Wrench equipped with a 13/16" (20mm) Deep Well Socket.
- 3) Remove Diverter Cartridge from Valve Body. Verify that the Lower Cartridge Seal is in place within the Diverter Cartridge, and not within the Valve Body.
- 4) Replace the Diverter Cartridge if necessary. When replacing the Diverter Cartridge, make sure that the mounting posts are aligned and engaged to the corresponding holes of the Valve Body.
- 5) Reassemble the Diverter Retaining Nut using a Socket Wrench equipped with a 13/16" (20mm) Deep Well Socket. Final torque should be 35-53 in*lb.
- 6) Open the Integral Stops of the Valve by turning the Stop Spindles counter-clockwise. Check for leaks.
- 7) Reassemble the Trim Parts.

CPV-T / CPV-T-DV REPAIR PARTS

SPEAKMAN®

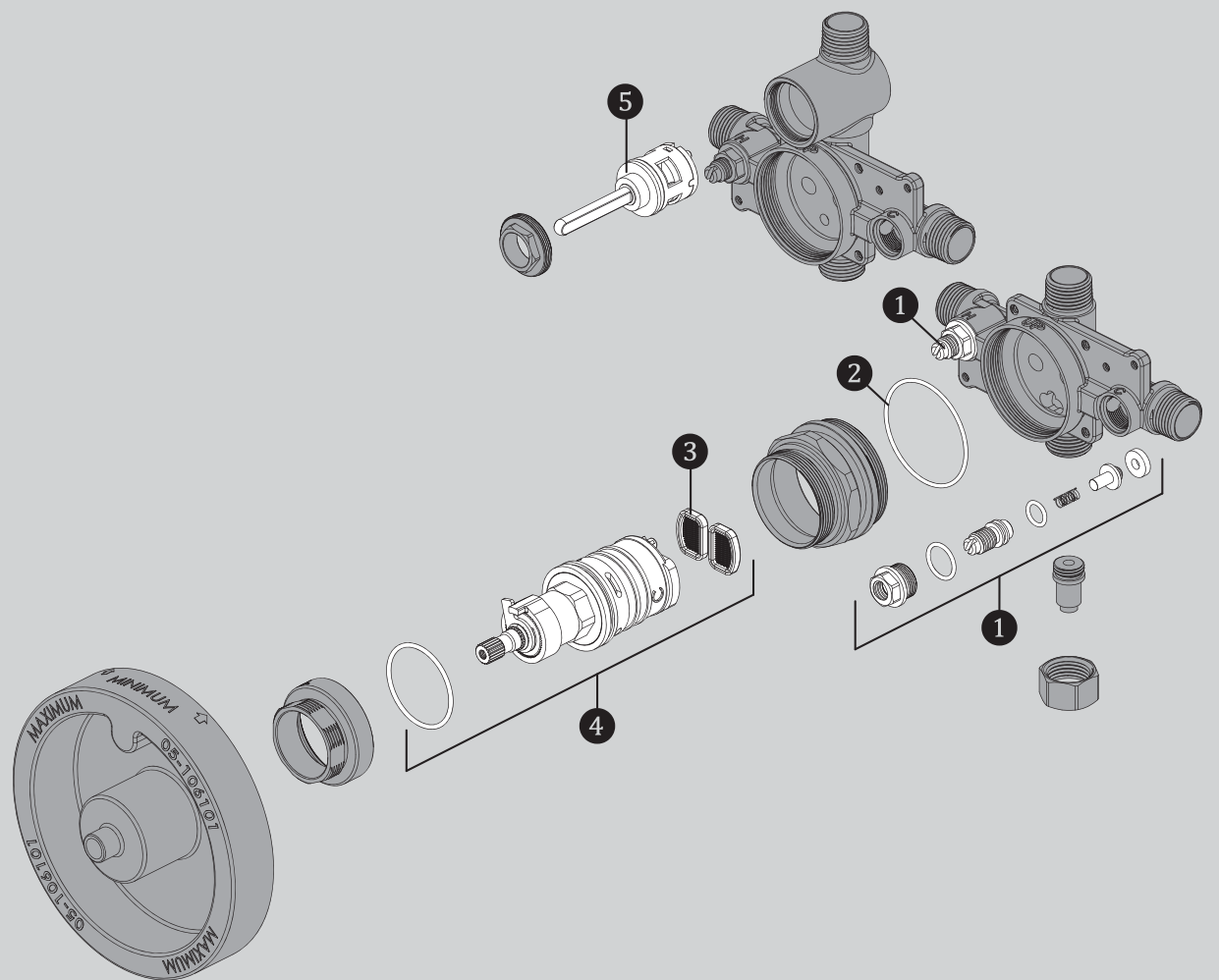

ITEM #	PART #	DESCRIPTION
1	RPG05-0862	CHECK STOP REPAIR KIT
2	RPG49-0012	BONNET O-RING
3	RPG49-0013	LOWER SEALS OF THERMOSTATIC CARTRIDGE
4	RPG05-1121	THERMOSTATIC CARTRIDGE
5	RPG05-0897	VOLUME CONTROL/DIVERTER CERAMIC REPAIR CARTRIDGE

CPV-T ROUGH-IN DIAGRAM

SPEAKMAN®

NOTES:

COMPLIANCE:

ASME A112.18.1/CSA B125.1
 ASSE1016/ASME A112.1016/CSA B125.16

CONNECTIONS:

Hot/Cold Inlets: 1/2" Female Copper Sweat
 1/2" NPT Male

Shower Outlet: 1/2" Female Copper Sweat
 1/2" NPT Male

Tub Outlet: 1/2" Female Copper Sweat
 1/2" NPT Male
 (Cap included for Shower Only Connections)

NOTES:

This valve is designed to be used in conjunction with a shower-head rated at 1.5 gpm (5.7 L/min) or higher flow rate

Contractor to supply necessary inlet connections.

DIMENSIONS SUBJECT TO CHANGE WITHOUT NOTICE.
 FOR ADA MOUNTING LOCATIONS, CONSULT ADAAG, ANSI A117.1, AND STATE REGULATIONS.

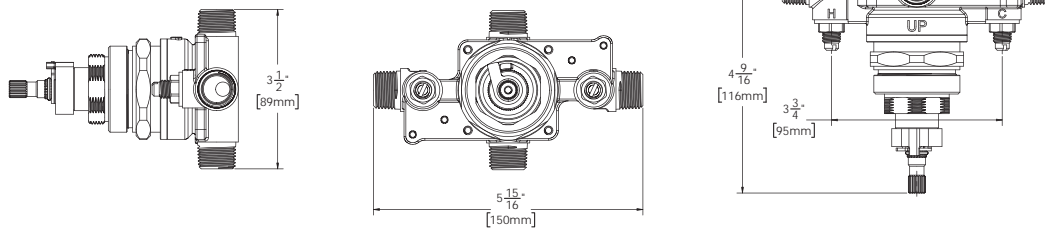
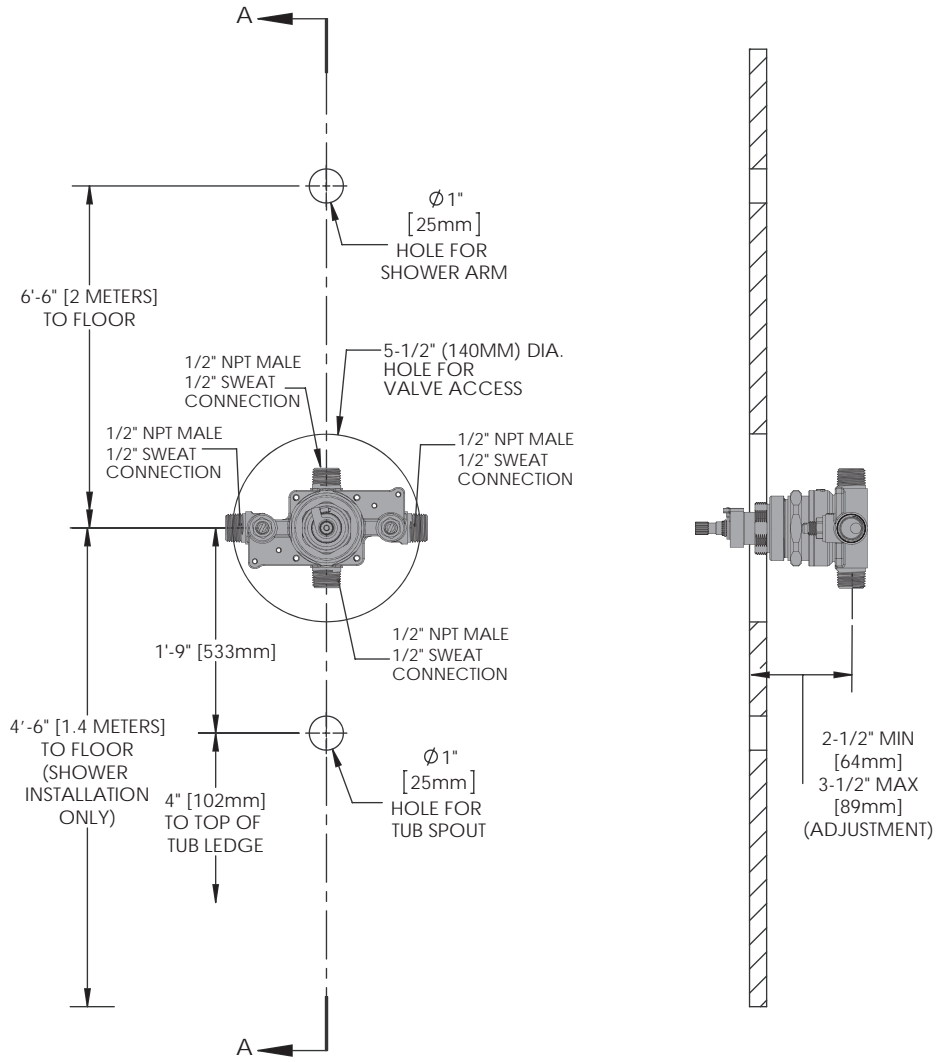

DIMENSIONS SUBJECT TO CHANGE WITHOUT NOTICE.

CPV-T-DV ROUGH-IN DIAGRAM

SPEAKMAN®

NOTES:

COMPLIANCE:

ASME A112.18.1/CSA B125.1
 ASSE1016/ASME A112.1016/CSA B125.16

CONNECTIONS:

Hot/Cold Inlets: 1/2" Female Copper Sweat
 1/2" NPT Male

Shower Outlet: 1/2" Female Copper Sweat
 1/2" NPT Male

Tub Outlet: 1/2" Female Copper Sweat
 1/2" NPT Male
 (Cap included for Shower Only Connections)

NOTES:

This valve is designed to be used in conjunction with a shower-head rated at 1.5 gpm (5.7 L/min) or higher flow rate

Contractor to supply necessary inlet connections.

DIMENSIONS SUBJECT TO CHANGE WITHOUT NOTICE.
 FOR ADA MOUNTING LOCATIONS, CONSULT ADAAG, ANSI A117.1, AND STATE REGULATIONS.

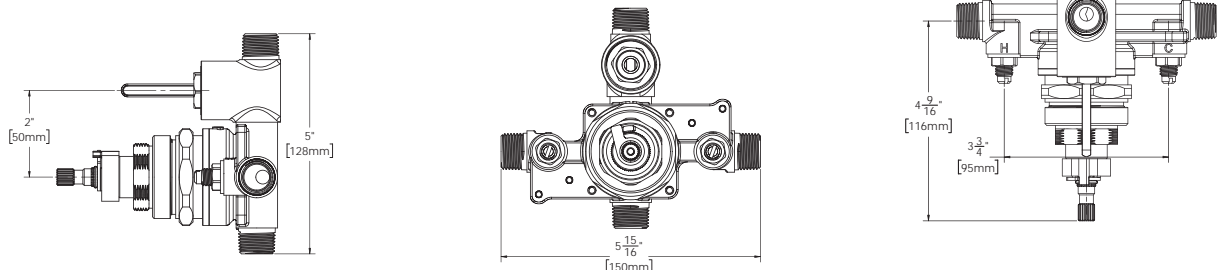
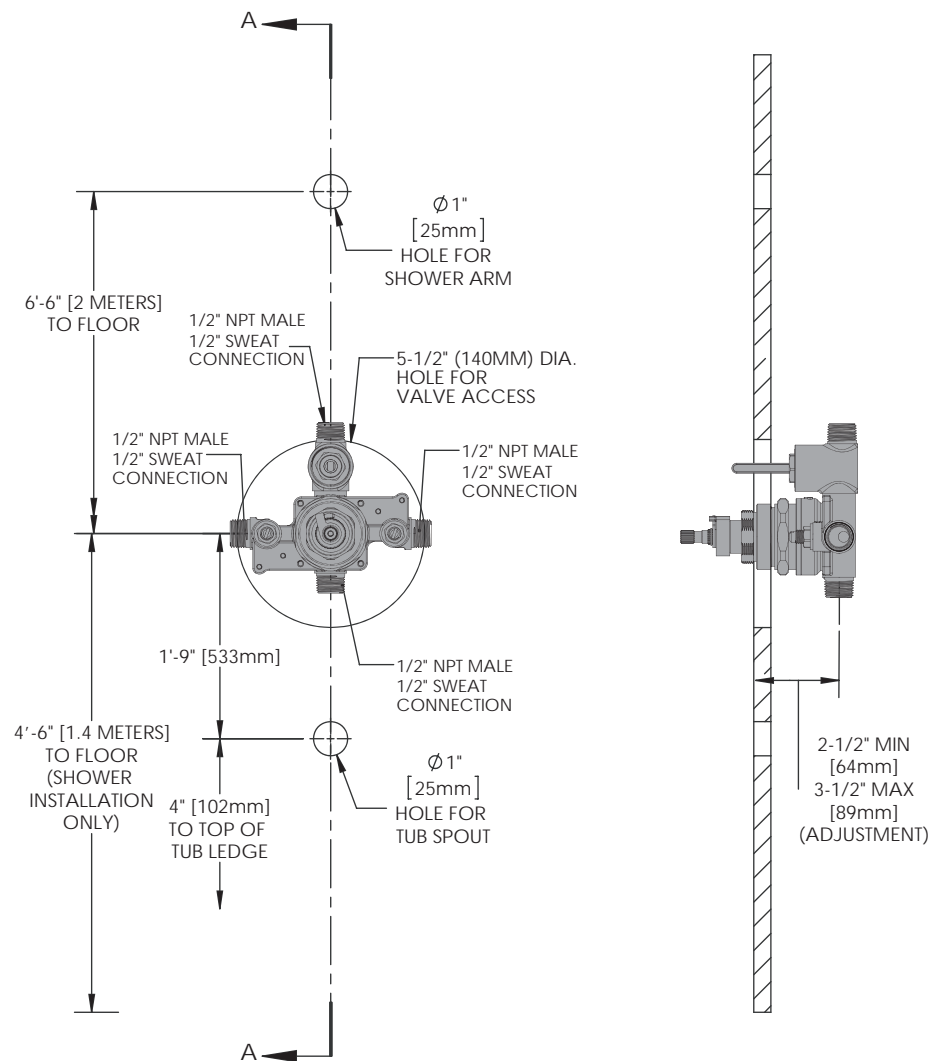

DIMENSIONS SUBJECT TO CHANGE WITHOUT NOTICE.