

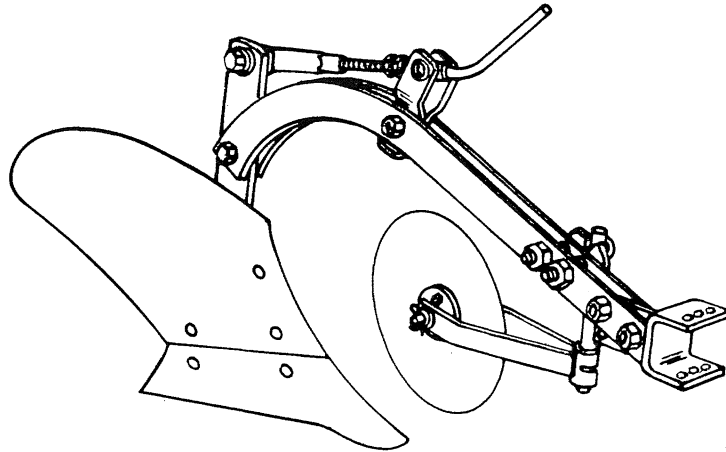

PLOW 10-INCH

OWNER'S MANUAL

SERIES NO. PP-51
MODEL NO. PP-510



- Assembly
- Installation
- Operation
- Repair Parts

THIS IMPLEMENT FOR USE WITH GARDEN TRACTORS EQUIPPED WITH SLEEVE HITCH. ALSO, TIRE CHAINS AND WHEEL WEIGHTS ARE RECOMMENDED.

"IMPORTANT: THIS MANUAL CONTAINS INFORMATION FOR THE SAFETY OF PERSONS AND PROPERTY. READ IT CAREFULLY BEFORE ASSEMBLY AND OPERATION OF THE EQUIPMENT!"

LIMITED WARRANTY

Brinly-Hardy Company warrants only to the original retail purchaser that this product will remain free of defects in workmanship and materials under normal use and service for a period of one (1) year (NOTE: ninety (90) days for commercial or rental use) commencing with the date of purchase.

Any parts found to be defective within the warranty period will be replaced, with proof of date of purchase, at Brinly Hardy Company's expense. Our obligation under this warranty is expressly limited to replacement or repair, at our option of parts which are defective in material or workmanship within thirty (30) days of receipt of the parts. This warranty does not apply to damage caused by unreasonable use, including failure to provide necessary maintenance, nor does it apply to any transportation or labor charges.

WE MAKE NO OTHER EXPRESS WARRANTY NOR IS ANYONE AUTHORIZED TO MAKE ANY ON OUR BEHALF. ANY IMPLIED OR STATUTORY WARRANTIES, INCLUDING ANY WARRANTY OF MERCHANTABILITY OR FITNESS FOR A PARTICULAR PURPOSE, ARE LIMITED TO THE DURATION OF THIS WRITTEN WARRANTY. WE SHALL NOT BE LIABLE FOR CONSEQUENTIAL OR INCIDENTAL DAMAGES OF ANY KIND.

BRINLY-HARDY COMPANY (877) 728-8224

MADE IN U.S.A.

CONGRATULATIONS on your purchase of this Brinly Implement. It has been designed, engineered, and manufactured to give you the best possible dependability and performance.

Please read and retain this manual. The instructions will enable you to assemble and maintain your Implement properly. Always observe the "SAFETY RULES".

Should the need ever exist for repair parts, order through most any Lawn and Garden dealer, using part number and description.



RULES FOR SAFE OPERATION

- Know controls and how to stop quickly, READ THE OWNER'S MANUAL.
- Do not allow children to operate the vehicle, do not allow adults to operate without proper instruction and without having read the owner's manual.
- Do not carry passengers. Keep children and pets a safe distance away.
- Always wear substantial footwear. Do not wear loose fitting clothing that can get caught in moving parts.
- Keep your eyes and mind on your tractor/attachment and area being covered. Don't let other interests distract you.
- Stay alert for holes in the terrain and other hidden hazards.
- Keep the vehicle and attachments in good operating condition and keep safety devices in place.
- Keep all nuts, bolts and screws tight to be sure the equipment is in safe working condition.
- The vehicle and attachment should be stopped and inspected for damage after striking a foreign object. The damage should be repaired before restarting and operating the equipment.
- See tractor equipment owner's manual for safe operation of the equipment.
- Do not drive close to creeks, ditches and public highways.
- Watch out for traffic when crossing or near roadways.
- When using any attachment, don't allow anyone near the vehicle while in operation.



WARNING !!!

- Plow share and coulter blade edges are sharp!!! Wear gloves when handling.
- Always LIFT the plow before turning!!
- Lock Tractor Lift Handle down when installing or removing plow!



LOOK FOR THIS SYMBOL TO POINT OUT IMPORTANT SAFETY PRECAUTIONS. IT MEANS - ATTENTION! BECOME ALERT! YOUR SAFETY IS INVOLVED.

CUSTOMER RESPONSIBILITIES

- Read and observe the "SAFETY RULES".
- Follow a regular schedule in maintaining, caring for and using your Plow.

TABLE OF CONTENTS

WARRANTY.....	1	PLOWING TIPS.....	6
SAFETY RULES.....	2	ADJUSTMENTS.....	7&8
ASSEMBLY.....	4&5	MAINTENANCE.....	8
OPERATION.....	5&6	TROUBLE SHOOTING.....	9
REPAIR PARTS.....	10		

Z-1216-A HARDWARE BAG



No. 1 B-1674P
Hex (Lock) Nut, 5/16"
3 Used

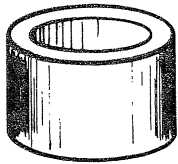

No. 26 P-597
Spacer
5/8" I.D. x 1/2"
2 Used.

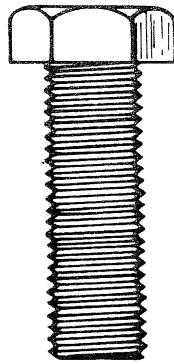

No. 28 1M1624P
Hex Head Bolt
1/2" x 1-1/2"
2 Used

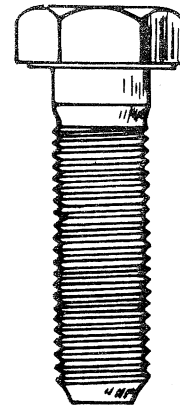

No. 29 1M1628P
Hex Head Bolt
1/2" x 1-3/4"
2 Used

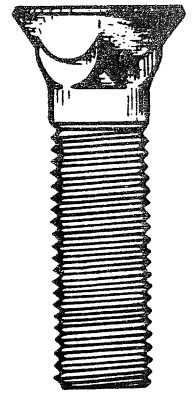

No. 35 15M1632P
Plow Bolt
1/2" x 2"
1 Used

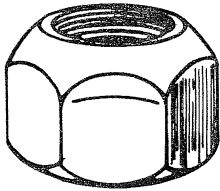

No. 3 B-1678P
Hex (Lock) Nut, 5/8"
2 Used.

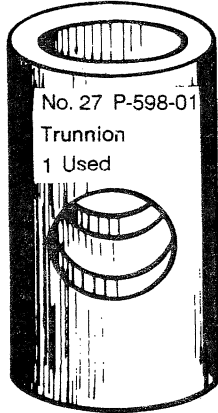

No. 27 P-598-01
Trunnion
1 Used

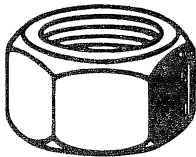

No. 39 30M2000P
Hex Nut, 5/8"
2 Used



No. 42 45M1111P
Flat Washer, 5/16"
3 Used



No. 44 45M1717P
Flat Washer, 1/2"
1 Used



No. 45 45M2121P
Flat Washer, 5/8"
2 Used

Z-1216-B HARDWARE BAG

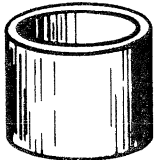

No. 7 P-234
Spacer
1/2" I.D. x 9/16"
1 Used.



No. 17 P-270
Drive Pin
5/16" x 1-1/4"
1 Used.



No. 33 15M1216-R
Plow Bolt
3/8" x 1"
2 Used

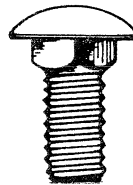

No. 31 10M1012P
Carriage Bolt
5/16" x 3/4"
3 Used

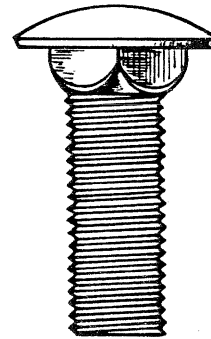

No. 32 10M1624P
Carriage Bolt
1/2" x 1-1/2"
1 Used

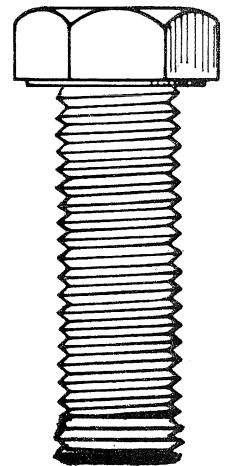

No. 30 1M2032P
Hex Head Bolt
5/8" x 2"
2 Used

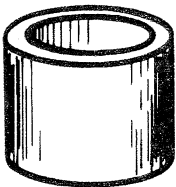

No. 14 P-262-01
Spacer
5/8" I.D. x 5/8"
1 Used.

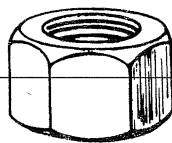

No. 38 30M1600P
Hex Nut, 1/2"
2 Used

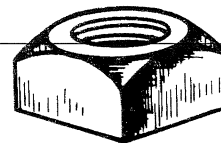

No. 41 35M1600P
Square Nut, 1/2"
1 Used

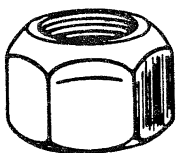

No. 2 B-1677P
Hex (Lock) Nut, 1/2"
3 Used



No. 36 30M1200P
Hex Nut, 3/8"
2 Used



No. 40 31M2000P
Hex (Jam) Nut, 5/8"
2 Used

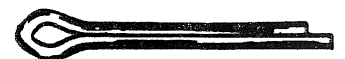

No. 46 50M0420P
Cotter Pin
1/8" x 1-1/4"
1 Used

Z-1216-C HARDWARE BAG

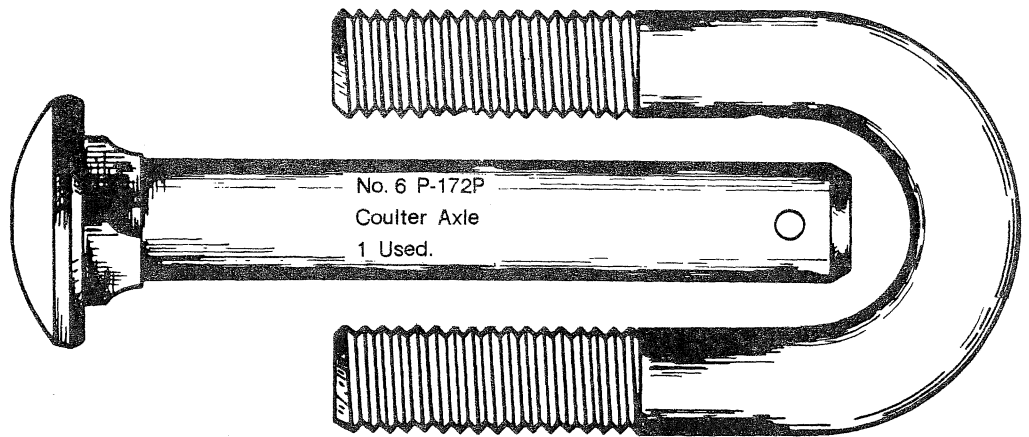
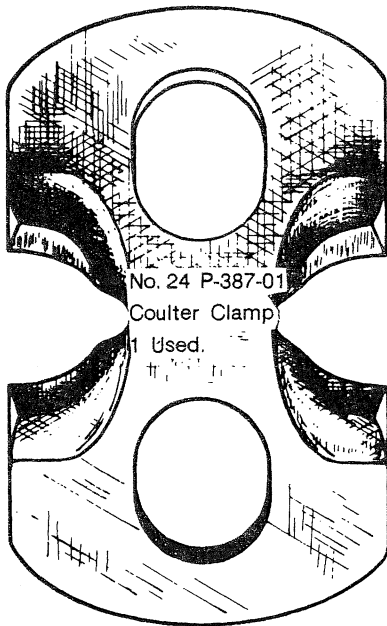

No. 23 P-386P
"U" Bolt
1 Used

ASSEMBLY

NOTES:

- IT IS RECOMMENDED THAT YOU CAREFULLY READ THIS OWNER'S MANUAL BEFORE STARTING ASSEMBLY OF THE UNIT.
- Before starting assembly, arrange each kind of hardware into a group to ease assembly.
- Right hand (R.H.) and left hand (L.H.) are determined from the OPERATOR'S position while seated on the tractor.

PLOW FRAME

Refer to Fig. 1

NOTE: Securely tighten all fasteners ONLY after Plow assembly has been completed, unless noted otherwise.

- Assemble the two adjusting brackets to the inside of both beams using one 1/2" x 1-3/4" hex bolt and one 1/2" hex lock nut.
- Slip trunnion through the hole in each adjusting bracket and insert crank through the hole in "SIDE" of trunnion, through spacer, the two 5/8" jam nuts, and then thread into the threaded tube.
- Thread one jam nut against the spacer just enough to eliminate any excessive movement of the crank against the trunnion, taking care NOT to bind crank.
- Using two wrenches, lock the other jam nut against the first.
- Before assembling the hitch bracket BETWEEN both beams refer to the chart and measure the distance BETWEEN the rear wheels on your tractor for the proper position of the bracket.

Tools Required For Assembly:

- 1- 10" Adjustable Wrench
- 1- 15/16" Wrench
- 1- 13/16" Wrench
- 1- 3/4" Wrench
- 1- Pair of pliers
- 1- 1/2" Wrench
- 1- 9/16" Wrench
- 1- Pair Gloves

Distance Between Rear Tractor Wheels(inches)	Use Hole #
16-19	1R
19-21	2L
21-23	3L
Over 23	3L

TABLE 1

- Secure with two 5/8" x 2" hex bolts and 5/8" hex lock nuts.

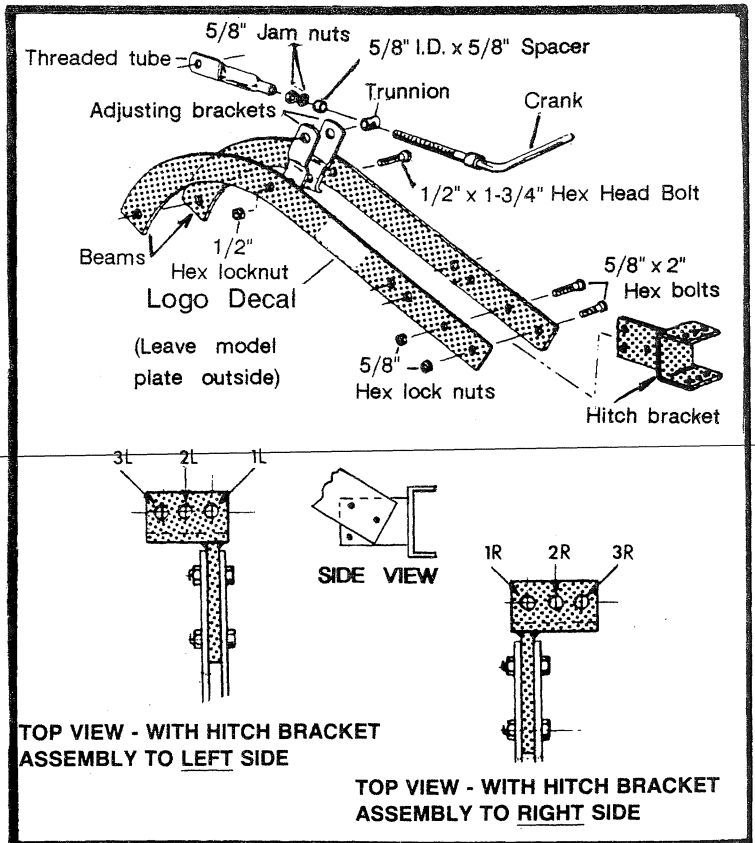

FIG. 1

PLOW BOTTOM AND STANDARD

Refer to Fig. 2

- Assemble the landside to frog using two 3/8" x 1" plow bolts and 3/8" hex nuts.
- Attach standard to frog using 1/2" x 2" plow bolt and 1/2" hex nut as shown.
- Insert the 1/2" x 1-1/2" carriage bolt through frog and standard and secure with a 1/2" hex nut.
- Insert one 1/2" x 1-1/2" Hex Bolt (Tracking Adjusting Bolt) through the "tab" at the bottom of standard. Place the 1/2" Square nut between the "Tab" and Frog, and thread the Tracking Adjusting Bolt into the square nut until tight.
- Tighten all fasteners securely.

PLOW FRAME AND BOTTOM (Refer to Fig. 3)

- Straddle the beams over standard and fasten together at the LOWER hole in the standard with one 1/2" x 1-3/4" bolt and 1/2" hex lock nut.
- Attach end of threaded tube to side of standard at the UPPER hole with a 1/2" x 1-1/2" hex bolt followed by the 1/2" flat washer, then place the 9/16" spacer in the hole in standard and secure this assembly with one 1/2" hex lock nut.
- Tighten these fasteners so that the threaded tube is free to pivot.

COULTER BLADE (Refer to Fig. 4)

- Insert coupler standard into fork, align the holes and drive the 5/16" x 1-1/4" pin through, leaving an equal amount of pin on each side.
- Attach the couler hub to the couler blade using three 5/16" x 3/4" carriage bolts, 5/16" flat washers, and 5/16" lock nuts.
- Install the couler blade on the fork by inserting the axle through one leg of the fork, the couler hub, and other leg of fork. Secure with the two 5/8" flat washers and 1/8" x 1-1/4" cotter pin, bend the legs over.
- Attach the couler assembly to the plow beam as shown, using the "U" bolt, couler clamp, two spacers (locate BETWEEN the plow beams), and secure with two 5/8" hex nuts.
- Position the couler standard between the "U" bolt and couler clamp and move up to the highest position.
- Refer to the couler adjustment section for proper setting, to be adjusted AFTER you begin plowing.



WARNING

- The "Attachment Clutch" Switch on dash of Tractor (device that engages Tractor Mower) needs to be ENGAGED at all times while operating Tractor. This actuates the Operators Sensing Device in the Tractor seat ---Tractor Engine will stop in case you dismount or fall off Tractor. Failure to actuate this device can cause personal injury or damage to your Tractor and Property if you were to fall off. SWITCH MUST BE DISENGAGED IN ORDER TO RESTART ENGINE!

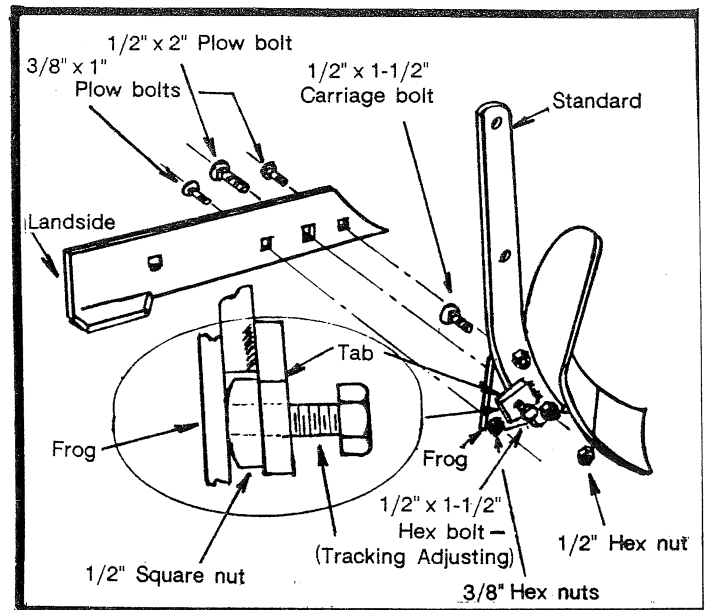

FIG. 2

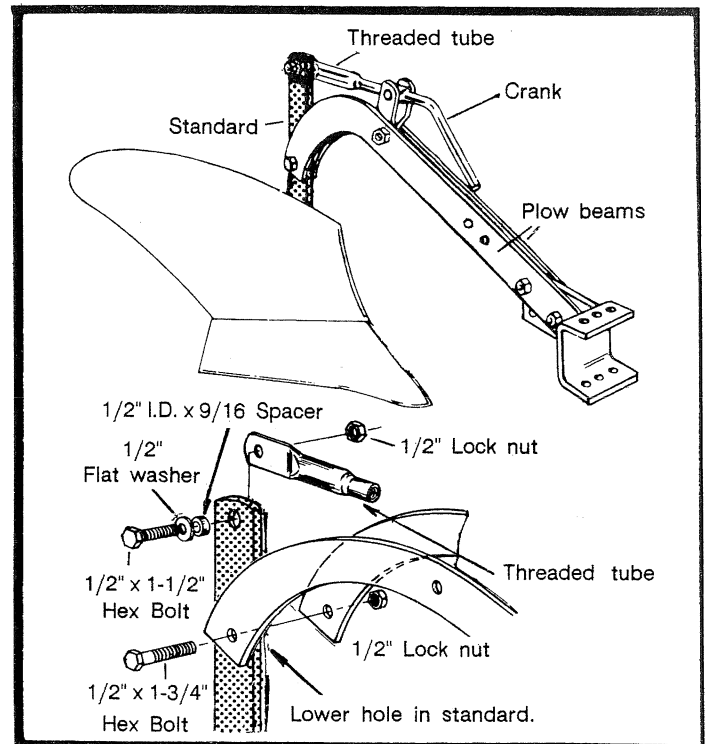

FIG. 3

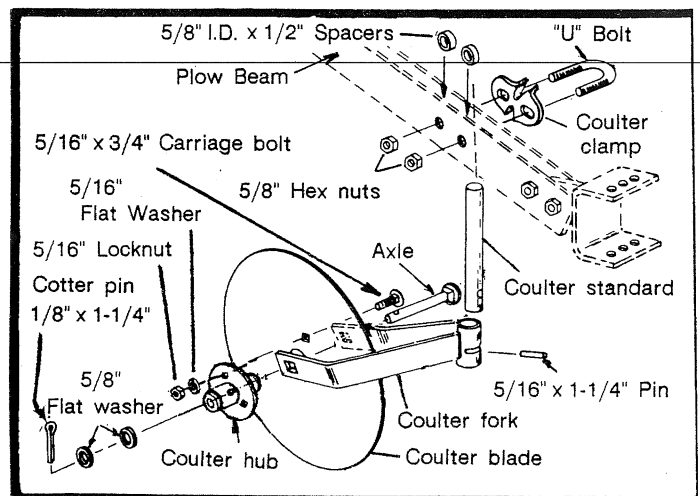

FIG. 4

OPERATION

PREADJUSTMENT (Refer to Fig. 5 and 6)

Note: During normal plowing, the right side Tractor Wheels will be riding in the previously plowed furrow. A furrow is the cut area your plow makes when turning the soil. An initial setting for your plow is required to cut the first furrow on level ground. The following pre-sets will result in an approximate 5" to 6" plowing depth.

- Remove Stabilizer Bolts and Nuts from Sleeve Hitch. The plow must be free to move side to side on Hitch.
- Lower your Tractor Lift Handle and lock in Lowered Position. You may need to Lower the "Attachment Depth Control" on your Tractor to do this.
- Mount the Plow to the Sleeve Hitch with the Hitch Pin furnished with the Hitch. Refer to Figure 1 and Table 1 to select the proper mounting hole.
- Adjust Lift Spring Tension on Hitch as required, see Hitch Manual for instructions.
- Adjust the Depth Crank of Plow until Point of Plow Share is approximately 1" off the ground. (Refer to Figure 5)

Note: The Plow will appear to be angled to left. This will allow the Plow to run level when the Right Hand Tractor Wheels are in the plowed furrow.

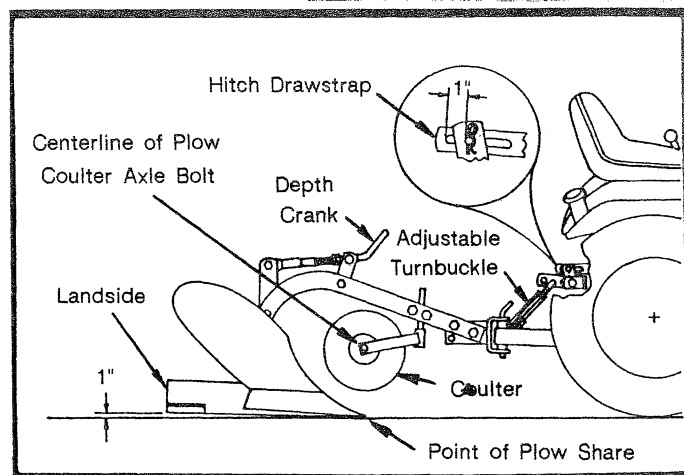

FIG. 5

- Adjust the Plow Coulter to its highest position.
- Go and make your first two furrows as described in the diagram (X to A and turn B to C). Make sure the Tractor Lift Handle is Lowered and Locked into the down position. Plow in Third Gear and near Full Throttle. Raise the Plow to the Transport Position when turning.
- If your Plow is not plowing at 4" to 5" deep on your initial two passes, readjust the Plow Depth Crank by turning it clockwise (↻) to go deeper or counter-clockwise (↺) to go shallower. (See Fig. 8) Make this adjustment ONE TURN at a time until desired depth is obtained.

Note: The rest of the furrows will be made with the Tractor Tires in the previously cut furrows; therefore, the Pitch (Depth) of the Plow must be readjusted to a 5" to 6" plowing depth.

- Position your Tractor with the inside of the Right (Side) wheels against the side of the previously plowed furrow.
- Start plowing for a short distance and check the depth of the furrow. Adjust the Depth Crank Clockwise or Counter-Clockwise ONE turn at a time and

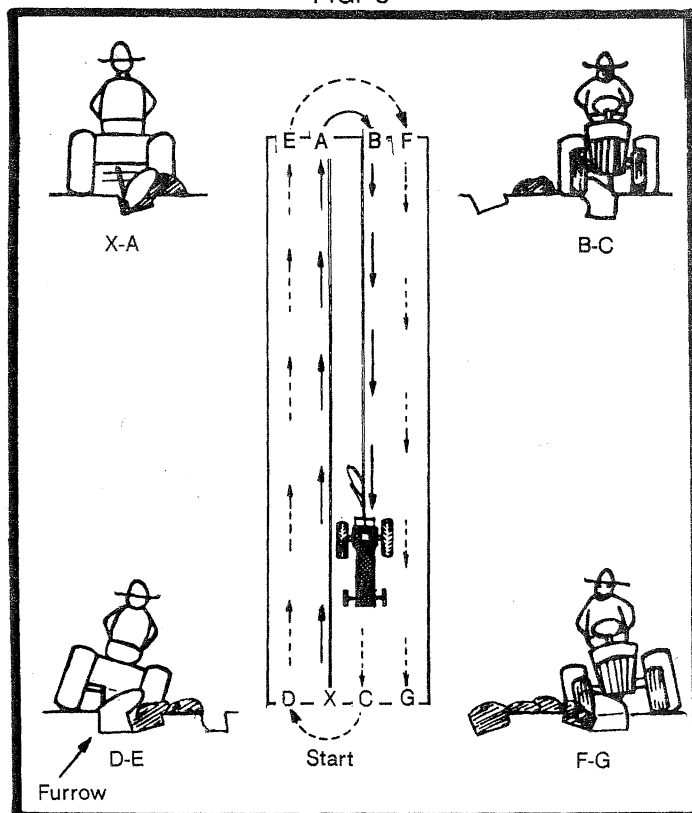

FIG. 6

retry until the 5" to 6" depth is obtained.

- After plowing depth is set with plow in furrow, stop the Tractor and measure the distance from the centerline of the Plow Coulter Axle Bolt --- it should be about 2" above the ground. If it is not, raise the Plow out of the ground and adjust the Coulter up or down to obtain this dimension. Be sure to adjust side motion at this time. (See Coulter Adjustment page 8)

TRACKING ADJUSTMENT (OPTIONAL)

Note: If the Plow appears to track to the left while plowing, an adjustment is available to correct this condition. (Refer to Figure 9)

- The Tracking Adjustment is made by loosening both 1/2" Hex Nuts securing the Plow Bottom to the

Standard and turning the Tracking Adjustment Bolt Clockwise (↻) two turns. Retighten Hex Nuts securely. Repeat Adjustment as necessary until plow pulls straight at 10" from the adjacent plowed swath.

PLOWING TIPS

- High weeds or grass must be cut down with a rotary mower before plowing.
- NEVER plow when soil is wet. A rule of thumb is to pick up a handful of soil and roll it into a "ball". If soil does not crumble, it is too wet. If the soil is too dry, it may be difficult for the plow to penetrate properly.
- Avoid low areas, old roadways, paths, and other places where soil is overly packed.
- Expect to have some difficulty plowing thick sod. However, by using the proper settings for Coulter, Hitch, and Crank, you should be able to do a good job under most conditions.
- Do not tighten Stabilizer Bolts, the plow must be free to sway from side to side. (Refer to your Hitch Manual)
- Your 10" Plow will generally work best at a depth of 5 to 6 inches.

- Lay out your field to be plowed, and if possible make it rectangular in shape.
Note: It is easier to plow a few long furrows than many short ones. Leave some room at each end of the field for turning your tractor.
- ALWAYS LIFT THE PLOW BEFORE TURNING!!!
- Do not plow too fast! Move steadily along so that the earth will turn over and not fall back into the furrow. In most soils, this is done at FULL THROTTLE in Third Gear.
Note: If Plowing Speed changes, it may be necessary to re-adjust the Depth Crank to maintain desired plowing depth.
- In light soils, plowing may often be done in a higher Gear, but if you travel too fast, the furrows will be uneven and the dirt is apt to be thrown rather than rolled over.

TRACTION

- Wheel weights are required under most plowing conditions.
- Tire Chains or Rear Chevron Tires (Agricultural Tires) are also recommended with the Plow.
- When plowing heavy clay soil or sod, it will help to reduce the width of the plow cut. This can be accomplished by hitching the plow one or two holes to the LEFT of the recommended setting, (Refer to Fig. 1).

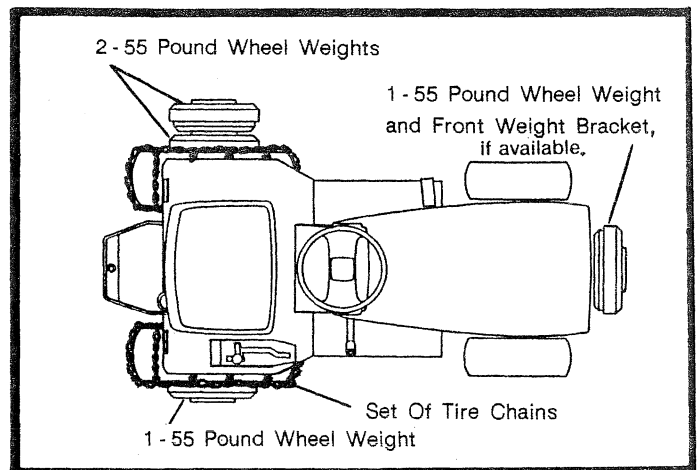

ADJUSTMENTS

COULTER ADJUSTMENT

Refer to Fig. 7

- The coulter should be adjusted to slice 2" to 3" deep when plow is in the ground. Make this adjustment by loosening the two hex nuts which secure the "U" bolt and then move the coulter assembly standard up or down as required.
- Rotate the coulter assembly to the LEFT so that the drive pin located in the standard prevents the coulter from swinging into the plow beam or bottom, now tighten the two hex nuts. When properly adjusted, the coulter will be free to swing OUTWARD a limited amount only, to the LEFT of the beam.
Note: In extremely hard soil, the coulter may actually prevent the plow from penetrating the surface. Should this situation occur, raise, or remove the coulter entirely.

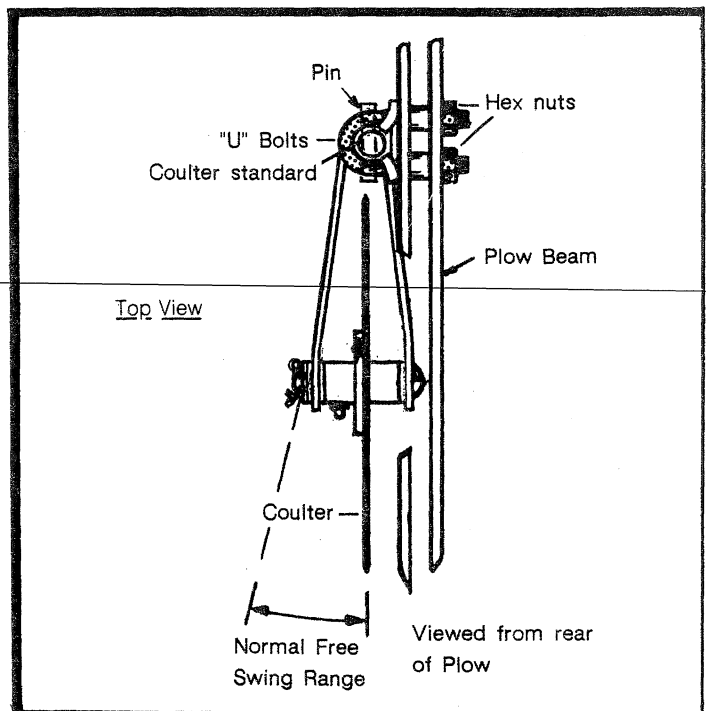

FIG. 7

DEPTH ADJUSTMENT

Refer to Fig. 8

- To turn the plow share into the ground to open the "first" furrow, adjust the point downward until the plow is cutting 4" to 5" deep.
- After a few furrows, (or desired depth is reached) turn the crank COUNTER-CLOCKWISE to maintain that depth. Do not allow landside to ride more than 1/2" off bottom of furrow as this will cause excessive wear on bottom of share resulting in poor soil penetration and loss of landside support.

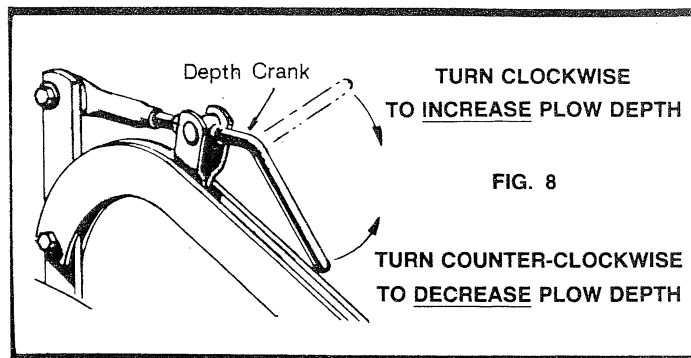

FIG. 8

TRACKING ADJUSTMENT

Refer to Fig. 9

NOTE:

- For most plowing conditions, the landside will be properly adjusted (from Fig. 2 assembly), enabling the plow bottom to react like a rudder while ground engaged. But if the tip of the plow share is too far LEFT of the beam, the plow will tend to overcut and leave a ragged furrow wall. This condition can be readily corrected by making the following adjustment.
- Loosen both 1/2" hex nuts securing plow bottom to the standard and then turn the Tracking Adjusting Bolt CLOCK-WISE two turns. Retighten hex nuts securely. Repeat adjustment as necessary until plow pulls straight behind tractor and is plowing 8" to 10" wide.

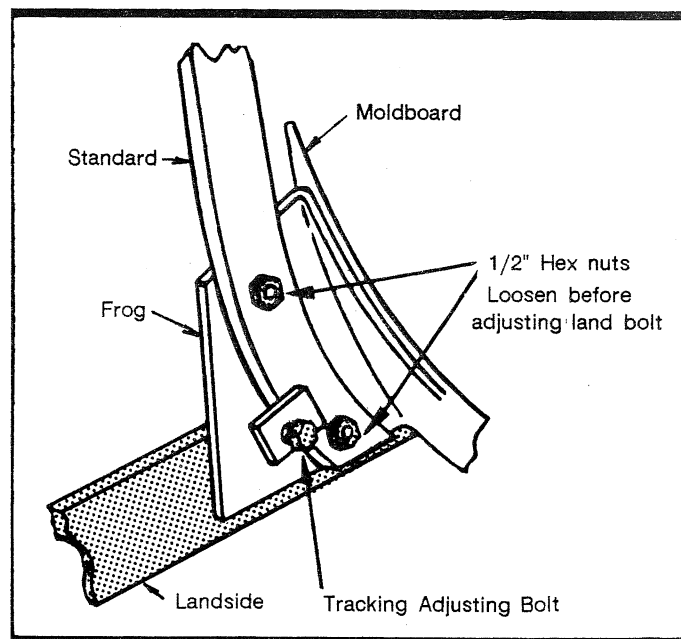

FIG. 9

MAINTENANCE

- The Moldboard should (after initial "scouring") be kept in a smooth, polished condition. Fine sandpaper, steel wool, kerosene, naphtha, etc. may be used to restore the finish on a rusty Moldboard.
- The Coulter Blade edge should be relatively sharp. If sharpening is necessary, use a flat file.

- Every 4 hours lubricate the Coulter Hub bearing surface through the grease fitting.
- For smooth operation and to prohibit the formation of rust on the crank, keep a light coating of oil on threads.

Note: When lubricating bearing, it is recommended that you use multipurpose grease.

TROUBLE SHOOTING (PLOWING DIFFICULTIES AND REMEDIES)

PROBLEM	CAUSE/CONDITION	REMEDY
SLOW GROUND ENTRY	<ul style="list-style-type: none"> ● Improper Crank Adjustment. ● Badly worn Plow Share. ● Ground extremely dry and hard due to lack of moisture. ● Hitch downward movement restricted by mower height adjustment. 	<p>Refer to Depth Adjustment and turn crank CLOCKWISE 1 or 2 turns at a time.</p> <p>Replace with a new Share.</p> <p>Add extra weight to tractor or wait until soil conditions are suitable.</p> <p>Adjust for shortest cut height.</p>
PLOW CUTTING TOO WIDE	<ul style="list-style-type: none"> ● Improper tracking adjustment. 	<p>See Tracking Adjustment</p>
PLOW BOTTOM WON'T POLISH	<ul style="list-style-type: none"> ● New or rusted bottom. 	<p>Clean bottom frequently during use until polish is obtained by: Clean bottom with rag soaked in turpentine, or mineral spirits. Old brick or pumice may also be used to polish bottom. Or, rub with a rag soaked in oil and dipped in sand.</p>
UNEVEN PLOWING DEPTH	<ul style="list-style-type: none"> ● Extreme variations in soil texture and/or moisture. ● Plow rides up in harder, dry soil, runs shallow. ● Plow goes too deep. 	<p>See plowing tips. Soil too wet or dry.</p> <p>Reduce tractor speed in hard spots. Check Depth Adjustment.</p> <p>Check Depth Adjustment, Turn Counter-clockwise.</p>

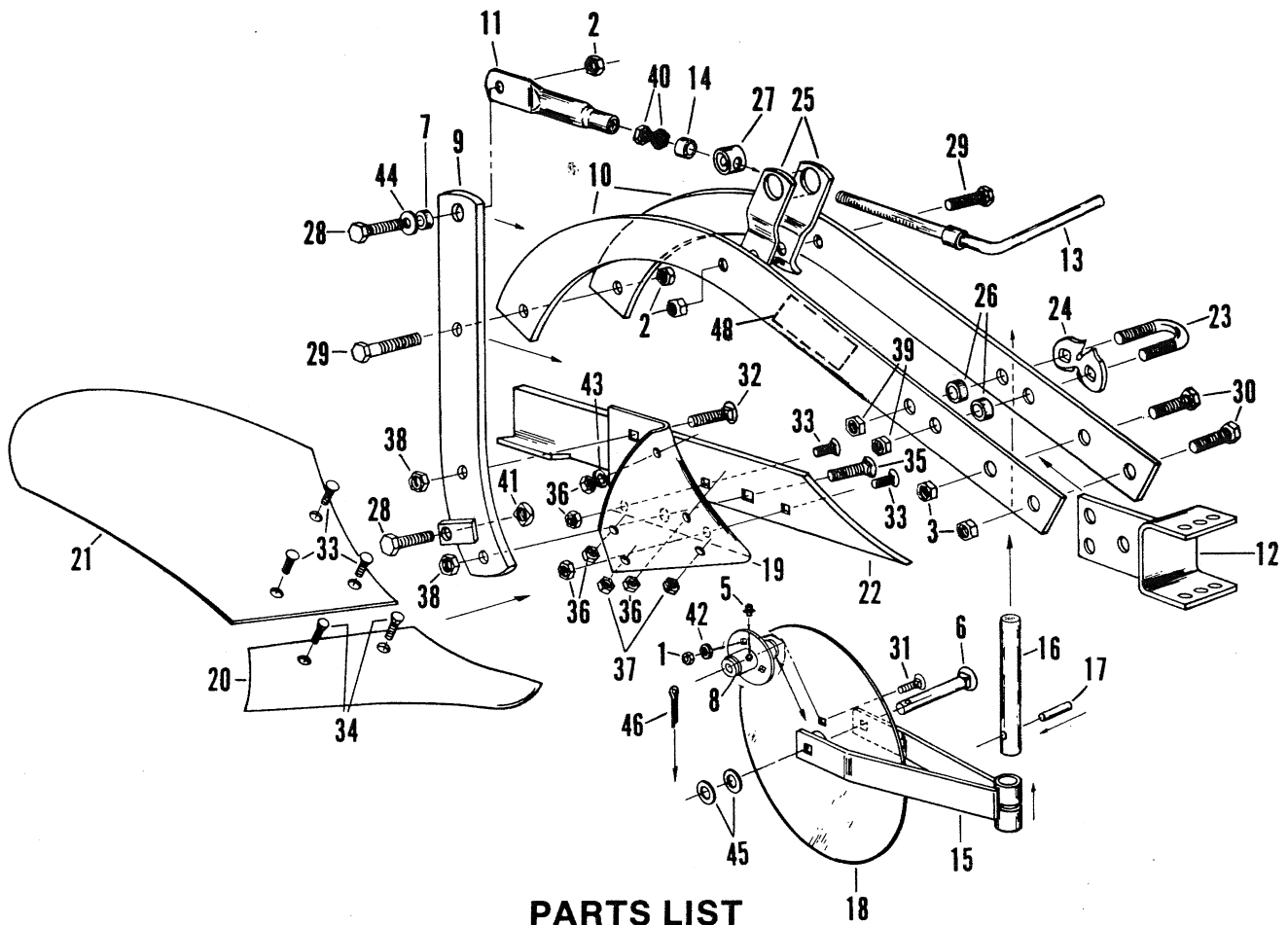

PARTS LIST

Ref. No.	Part No.	Description	Qty.	Ref. No.	Part No.	Description	Qty.
1	B-1674P	Hex Lock Nut, 5/16"	3	25	P-596-10	Adjusting Bracket	2
2	B-1677P	Hex Lock Nut, 1/2"	3	26	P-597	Spacer, 5/8" I.D. x 1/2"	2
3	B-1678P	Hex Lock Nut, 5/8"	2	27	P-598-01	Trunnion	1
5	D-128P	Grease fitting, 5/16"	1	28	1M1624P	Hex Head Bolt, 1/2" x 1-1/2"	2
6	P-172P	Coulter Axle	1	29	1M1628P	Hex Head Bolt, 1/2" x 1-3/4"	2
7	P-234	Spacer, 1/2" I.D. x 9/16"	1	30	1M2032P	Hex Head Bolt, 5/8" x 2"	2
8	P-250A	Coulter Hub	1	31	10M1012P	Carriage Bolt, 5/16" x 3/4"	3
9	P-251-10	Standard	1	32	10M1624P	Carriage Bolt, 1/2" x 1-1/2"	1
10	P-609-10	Beam Half	2	33	15M1216-R	Plow Bolt, 3/8" x 1"	5
11	P-256P-01	Threaded Tube	1	34	15M1416P	Plow Bolt, 7/16" x 1"	2
12	P-257-10	Hitch Bracket (Yoke)	1	35	15M1632P	Plow Bolt, 1/2" x 2"	1
13	P-260-01	Crank	1	36	30M1200P	Hex Nut, 3/8"	5
14	P-262-01	Spacer, 5/8" I.D. x 5/8"	1	37	30M1400P	Hex Nut, 7/16"	2
15	P-265A-10	Fork	1	38	30M1600P	Hex Nut, 1/2"	2
16	P-269A-10	Coulter Standard	1	39	30M2000P	Hex Nut, 5/8"	2
17	P-270	Pin, 5/16" x 1-1/4"	1	40	31M2000P	Hex (Jam) Nut, 5/8"	2
18	P-272A-10	Coulter Blade	1	41	35M1600P	Square Nut, 1/2"	1
19	P-273-10	Frog	1	42	45M1111P	Flat Washer, 5/16"	3
20	P-275-10	Share (10")	1	43	45M1313P	Flat Washer, 3/8"	1
21	P-278	Moldboard (10")	1	44	45M1717P	Flat Washer, 1/2"	1
22	P-287-10	Landside (10")	1	45	45M2121P	Flat Washer, 5/8"	2
23	P-386P	"U" Bolt	1	46	50M0420P	Cotter Pin, 1/8" x 1-1/4"	1
24	P-387-01	Coulter Clamp	1	47	L-1043-2	Owner's Manual	1
				48	B--59 22	Logo Decal	1