

ASSEMBLY INSTRUCTIONS

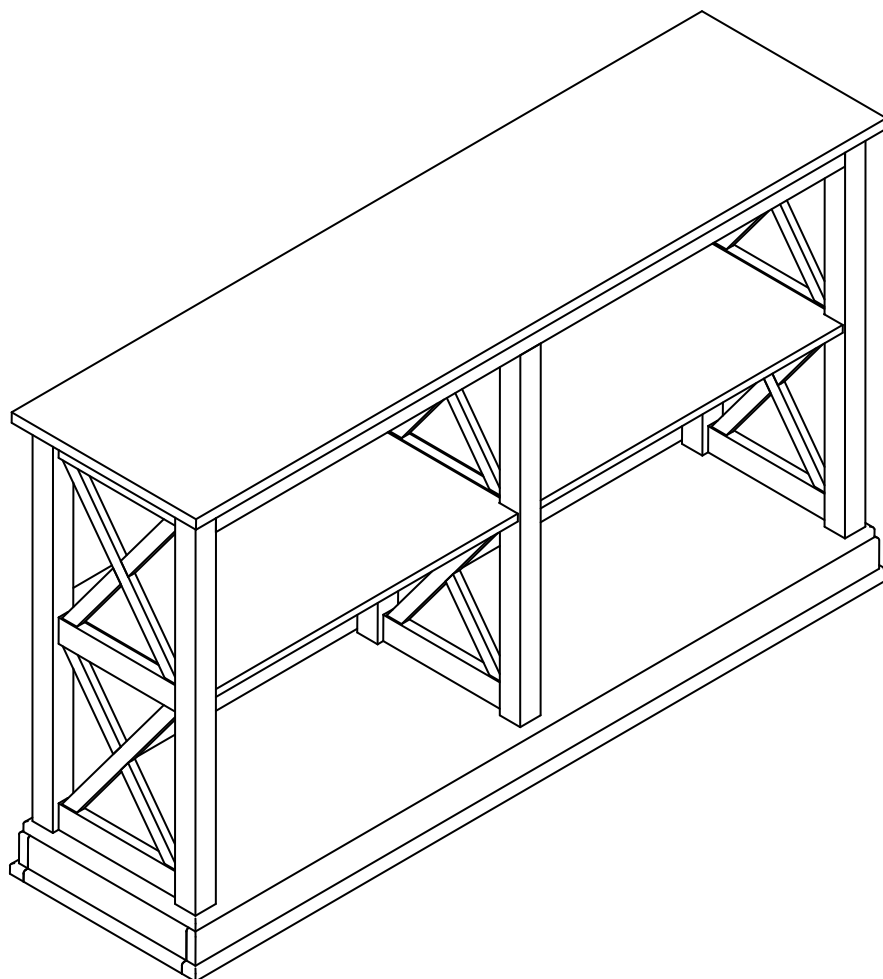

Description : HAMPTON SOFA TABLE WITH SHELVES
Item No. : OT-70SL

BEFORE ASSEMBLY

Thank you for purchasing this quality product. This product has been designed for easy assembly and constructed for durability. All parts were checked prior to packaging to insure quality. Prior to beginning assembly, however, make sure all parts and hardware are included and free of obvious defect. If a part is missing or defective, please contact the store where purchased. If hardware is missing, or you need help with assembly, please call toll free 888-944-8396.

IMPORTANT NOTE:

- Place all wooden parts on a clean and smooth surface such as a rug or carpet to avoid the parts from being scratched.
- Remove all wrapping material, including staples & packing straps before you start to assemble.
- DO NOT tighten all screws and bolts until completely assembled.
- Keep all hardware parts out of reach of children.

WARNING:

Long exposure to rubber or soft plastic may cause a chemical reaction and damage the finish of your table. Protect the surface of the table with cloth if you are using any product with rubber feet or base.

ASSEMBLY TOOLS REQUIRED NOT INCLUDED

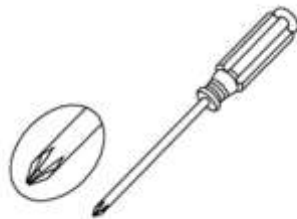

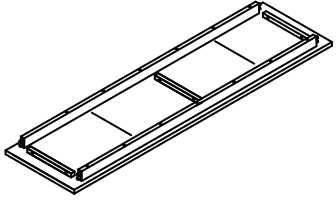
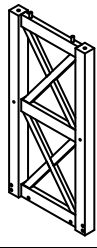
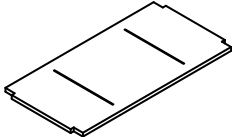
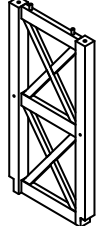
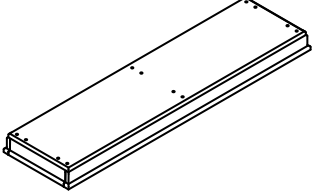

PART LIST

When unpacking, please be careful not to discard any parts with the packaging. Before continuing, please make sure you have the following parts:

NO	Description	Qty	Sketch	NO	Description	Qty	Sketch
A	Top	1		B	Side frame	2	
C	Adjustable Shelf	2		D	Vertical frame	1	
E	Bottom panel	1					

HARDWARE LIST

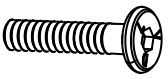
When unpacking, please be careful not to discard any parts with the packaging. Before continuing, please make sure you have all of the following hardware:

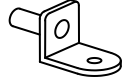
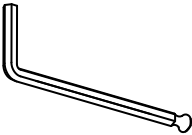
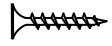
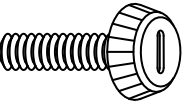
NO	Description	Qty	Sketch	NO	Description	Qty	Sketch
1	Long Bolt (M6 x 35mm)	12		2	Flat Washer (Φ6.5 x 19mm)	12	
3	Lock Washer (Φ6.5 x 11mm)	12		4	Shelf support bracket	8	
5	Allen Key (M4 x 30mm x 110mm)	1		6	Screw (M3.5 x 15mm)	8	
7	Leveler	4					

ITEM NO.: OT-70SL
REVISED MAR 02, 2020

Printed in Vietnam

STEP 1

Attach side frames (B) and vertical frame (D) to the top (A) with bolt (1), and washer (2) and (3) as shown below. Tighten with Allen key (5).

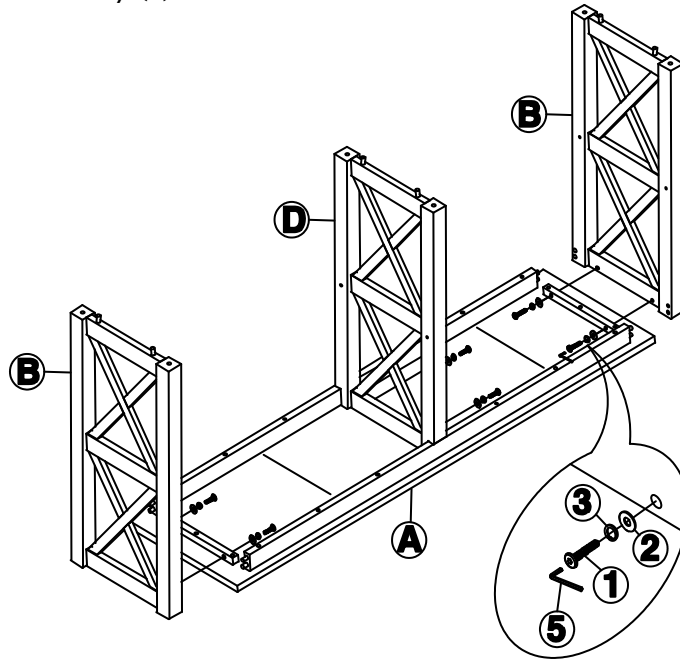

STEP 2

Attach bottom panel (E) to the unit with bolts (1), and washers (2) and (3) as shown below. Tighten with Allen key (5).

Attach levelers (7) by screwing them into bottom panel (E), as shown below.

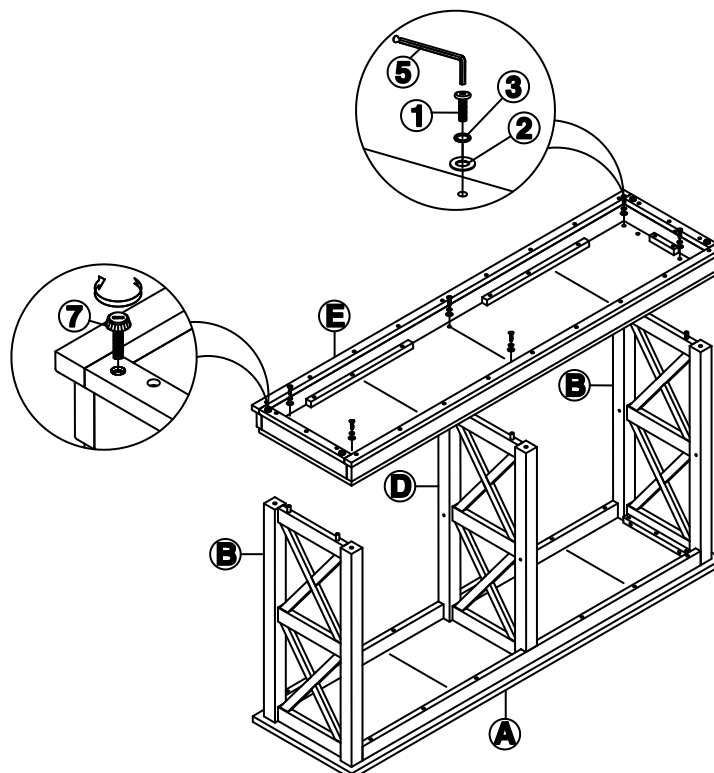

STEP 3

Insert brackets (4) into the unit as shown below. Place shelves (C) on the brackets and attach with screws (6). Tighten with a screwdriver.
Adjust the levelers to the appropriate height to level the table.

