

FOLDING ADIRONDACK CHAIR

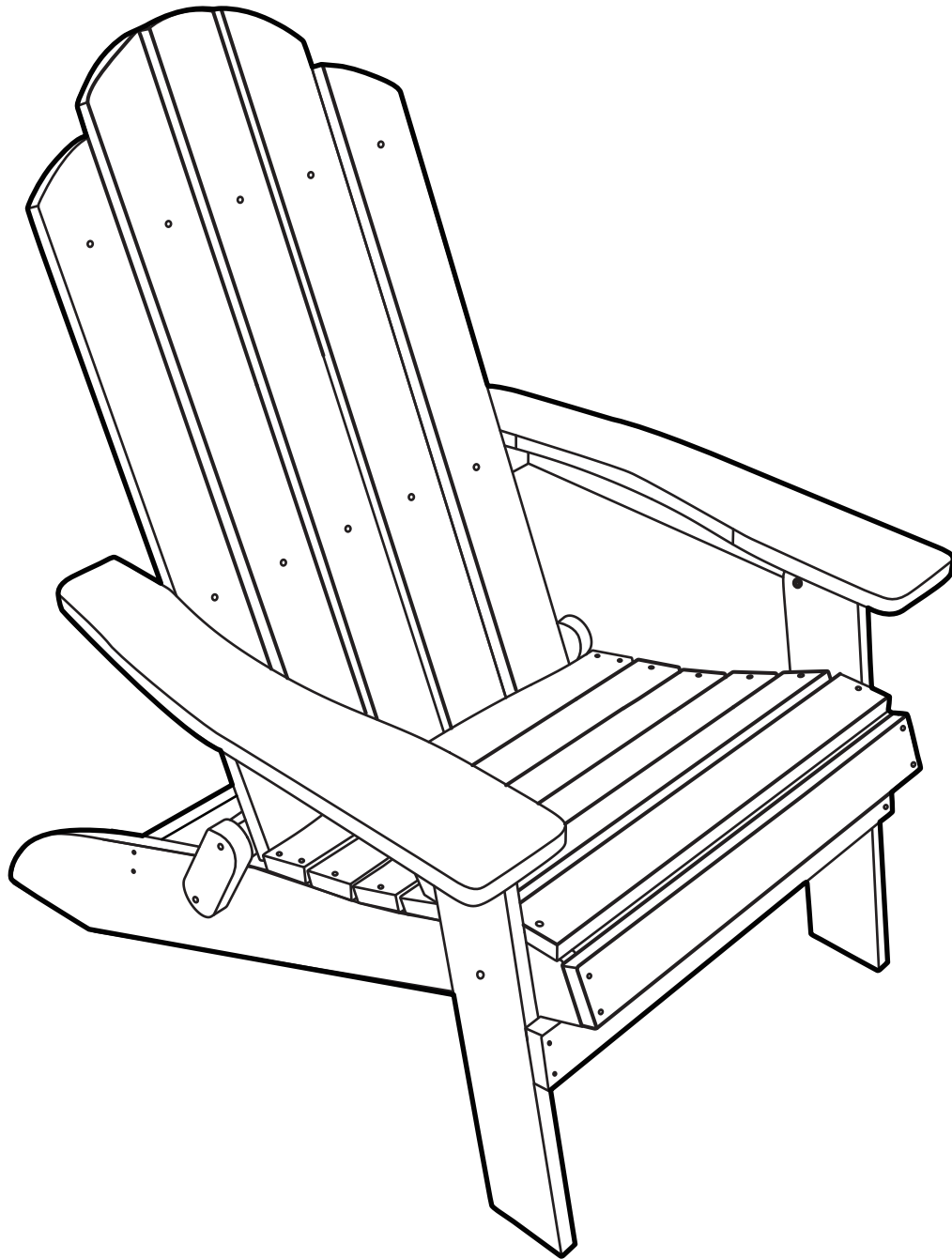





Thank You for Choosing Our Chair
For Parts and Service or Technical Support
Email 7 days a week at productservicecenter@yahoo.com

Before Assembly

Important Note:

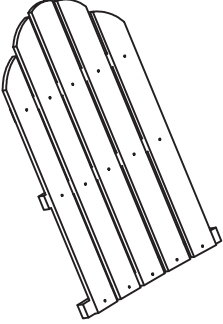
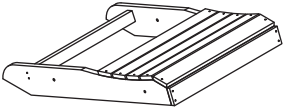
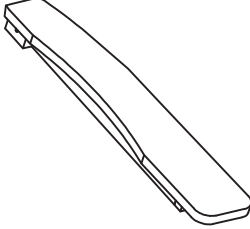
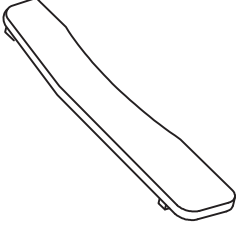
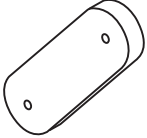
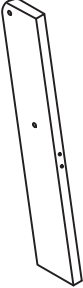
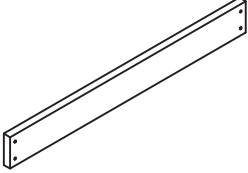
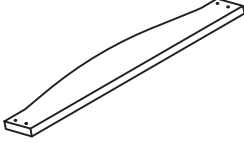
1. Make sure all parts and hardware are including and free of obvious defect before disposing of any packaging.
2. Do not tighten all screws and bolts until completely assembled.
3. Assembly will require two people.

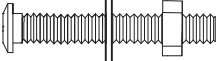
Packaging List

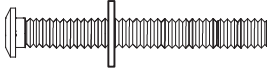
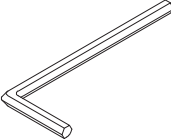
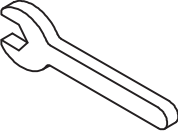
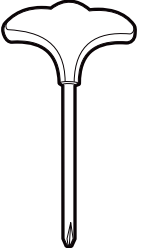
				
A x 1PC	B x 1PC	C x 1PC	D x 1PC	E x 2PCS
			 4*35 Screw	 M6*50 Bolt
F x 2PCS	G x 1PC	H x 1PC	AA x 8PCS	BB x 6PCS
 M6*50 Bolt	 M6*80 Bolt			
CC x 2PCS	DD x 2PCS	Allen wrench x 1PC	Wrench x 1PC	Screwdriver x 1PC

For Parts and Service or Technical Support
Email 7 days a week at productservicecenter@yahoo.com

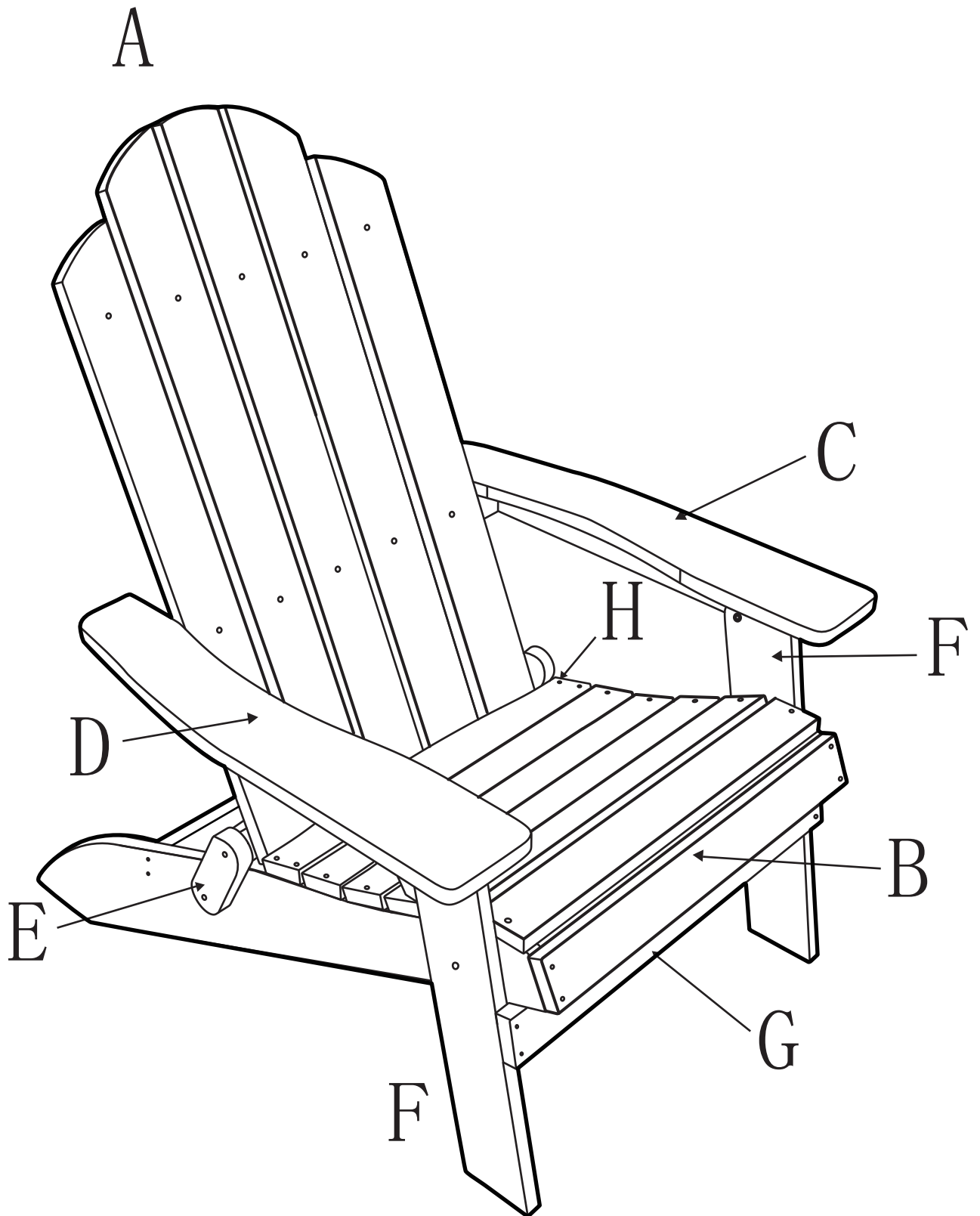

For Parts and Service or Technical Support
Email 7 days a week at productservicecenter@yahoo.com

Step 1

Attach (H) to Seat (B) by inserting Bolts (AA) on each side

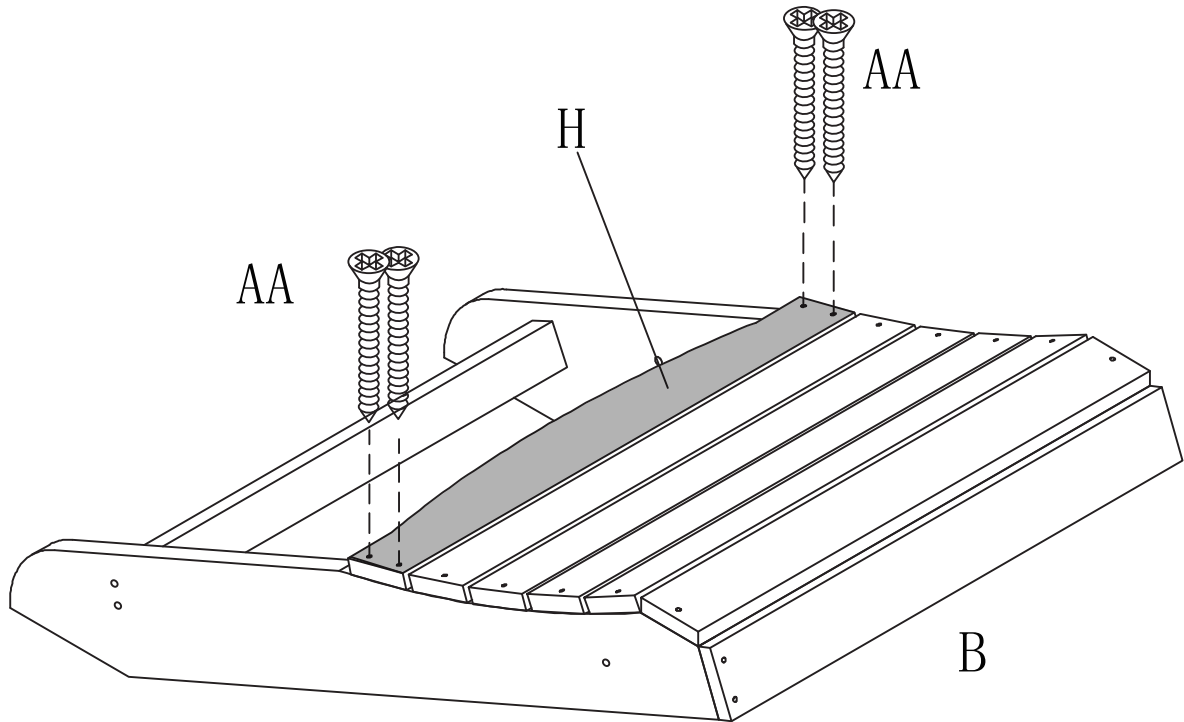

Step 2

Attach Front Legs (F) to Seat (B) by inserting Bolts (BB) on each side into the corresponding holes. Secure each bolt with a washer and a nut come with bolt(BB) as pictured.

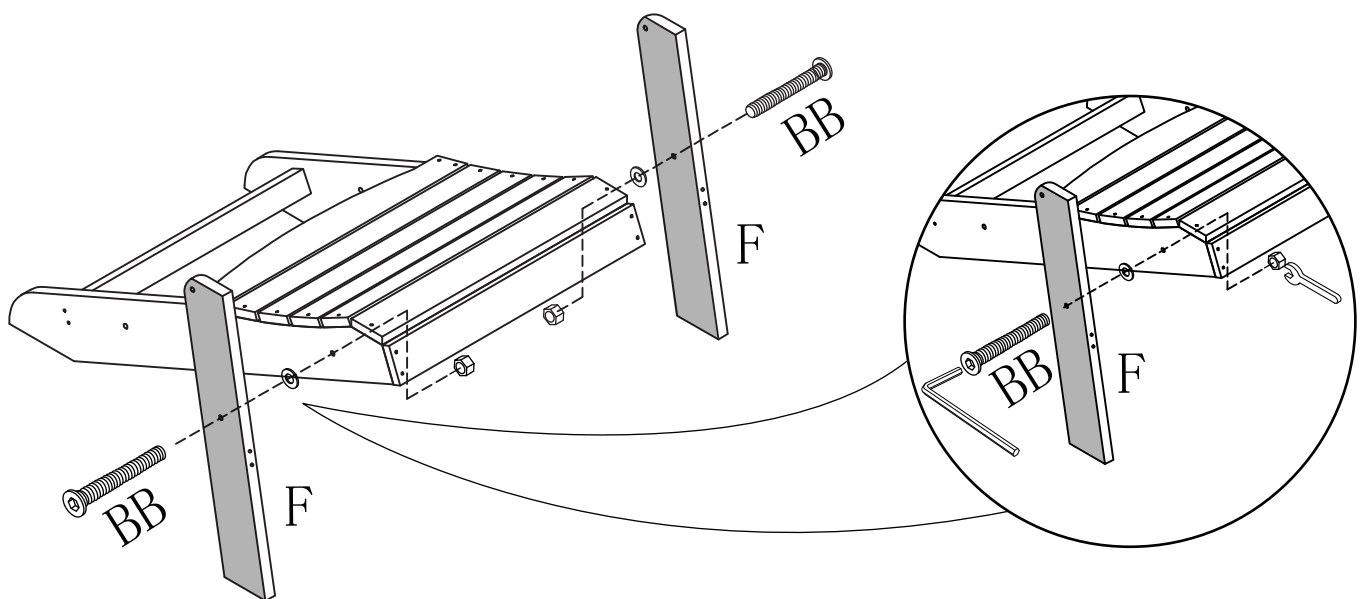

Step 3

Attach (G) to Front Legs (F) using bolts (AA) as pictured.

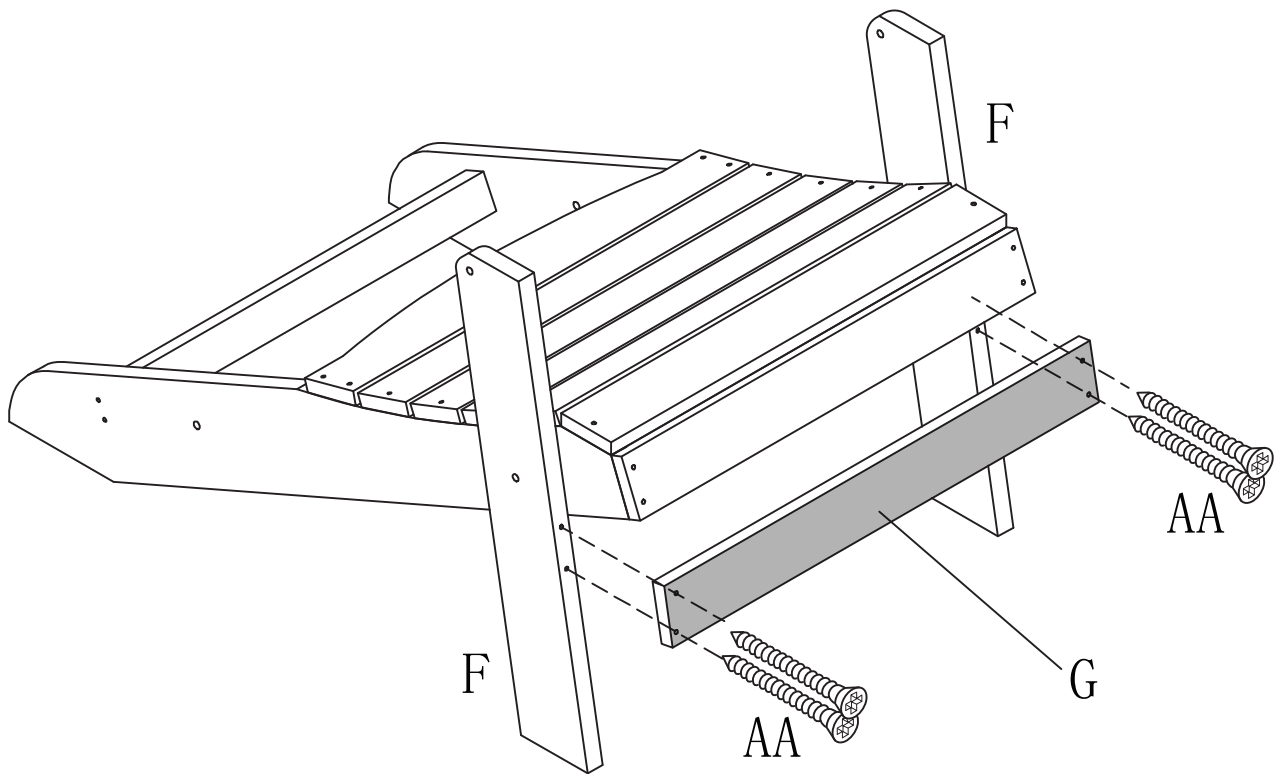

Step 4

Attach (E) to Seat (B) by inserting Bolts (BB) on each side and secure each bolt with a washer and a nut come with bolt(BB) as pictured on each side.

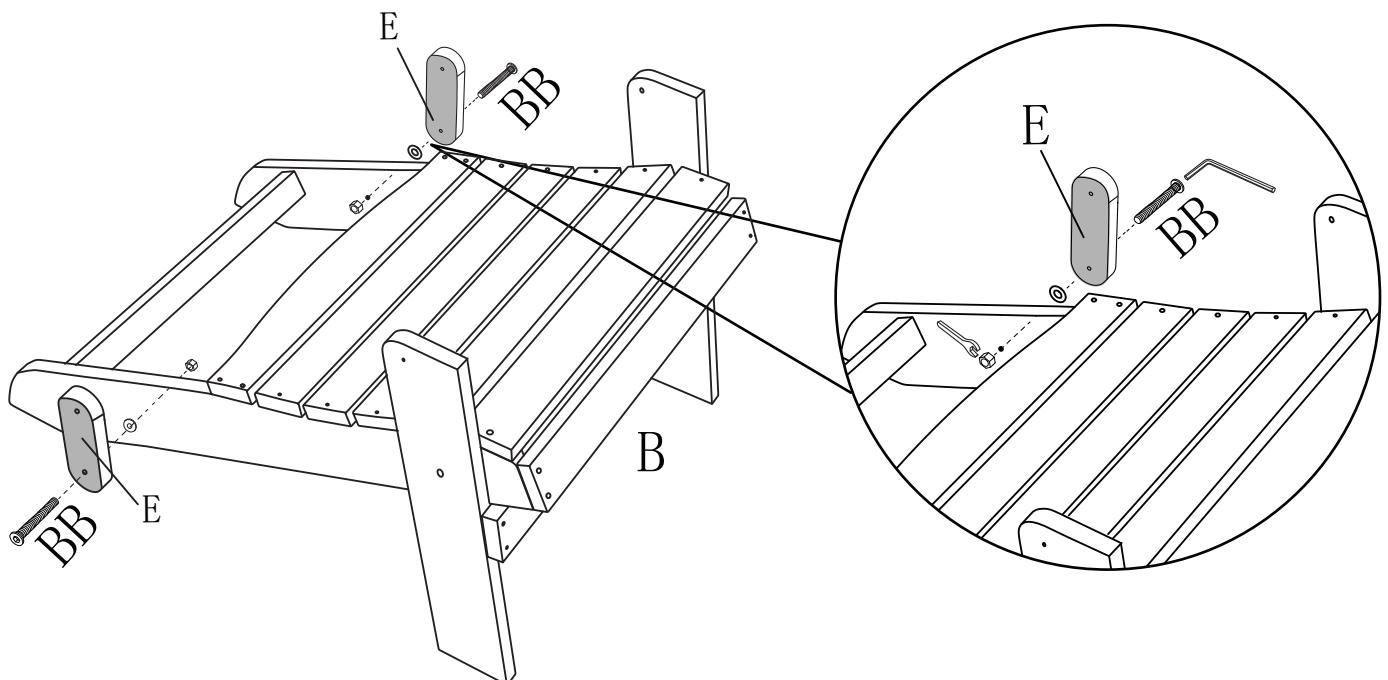

Step 5

Attach the the Arms (C) and (D) to the Front Legs (F) using Bolts (BB) and secure each bolt with a washer and a nut come with bolt(BB) as pictured.

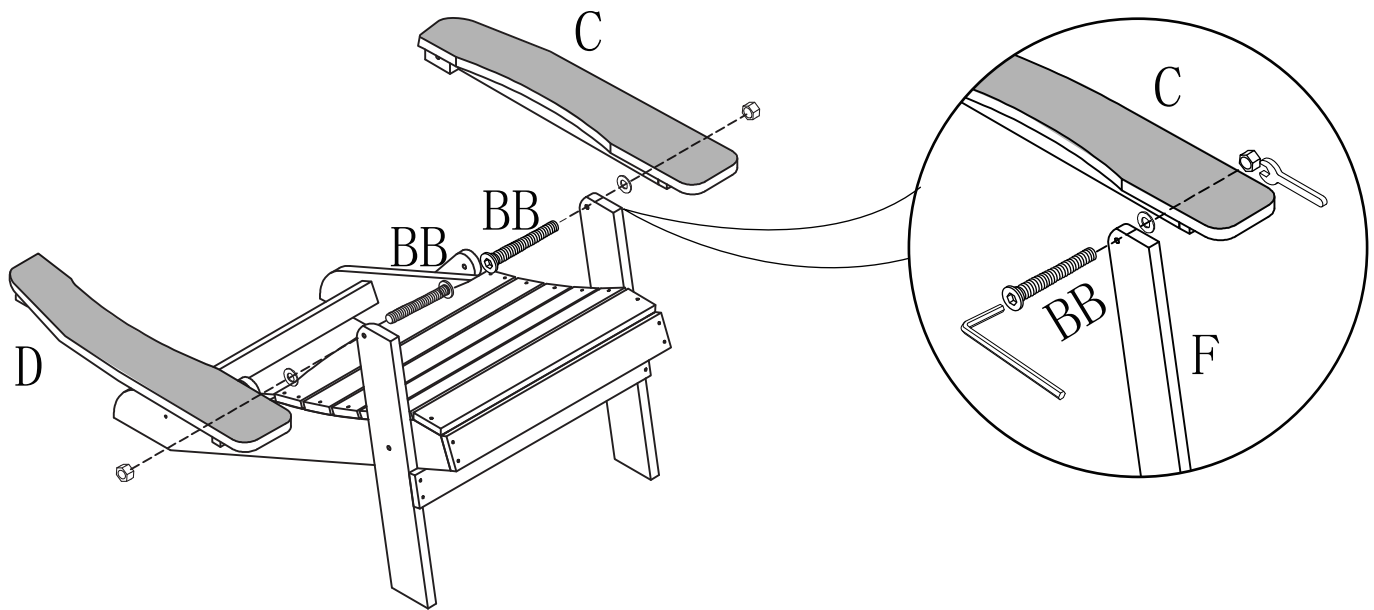

Step 6

Attach the Back (A) to the (E) using bolts (CC). Attach Back (A) to Arms (C) and (D) using bolts (DD) as pictured.

Finally, please make sure that do not over thight the screws, in order to fold smoothly, also not too loose, in order to maintain stability.

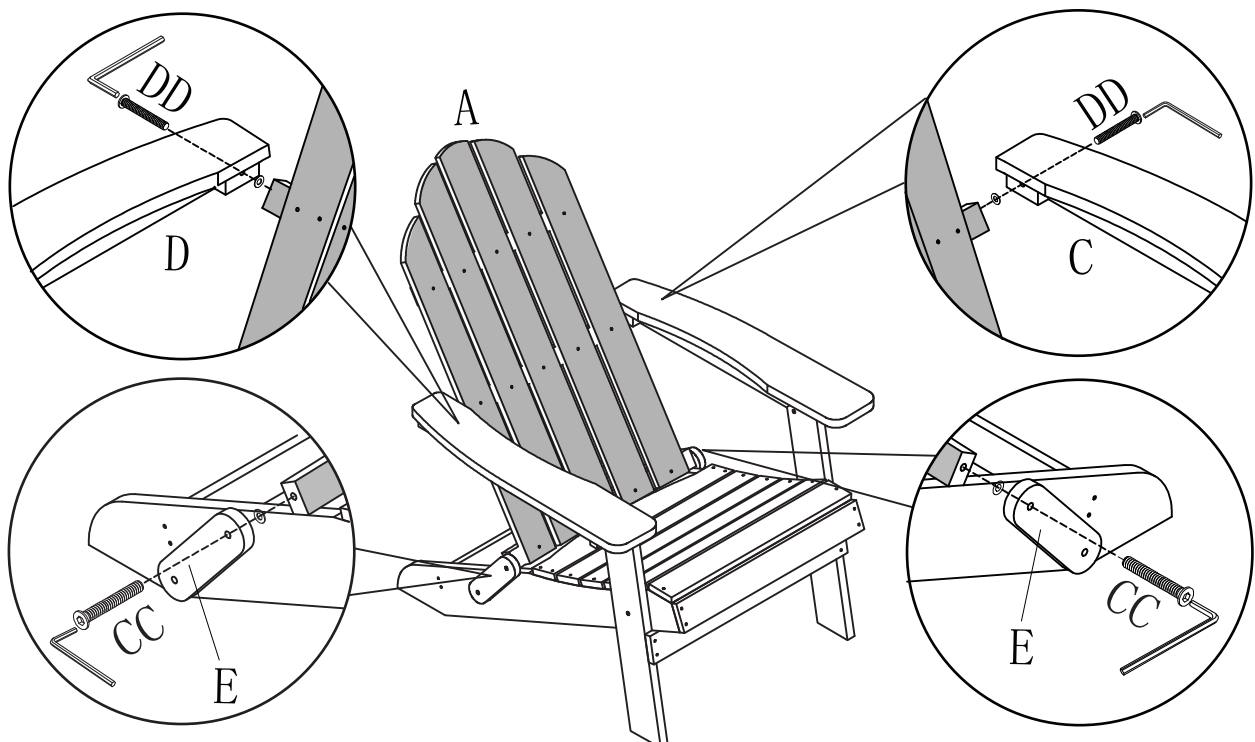

IMPORTANT NOTE!

NEVER adjust the level of recline while you are sitting in the chair, or while anyone else is in the chair.

Always adjust with an empty chair and ensure that the back support is completely secure in the recline slots on each side of the chair. To fold the chair, lift the back support and gently push down on the back of the chair. And the chair will collapse down to the floor level.

CUSTOMER SERVICE

For Parts and Service or Technical Support
Email 7 days a week at productservicecenter@yahoo.com

RETURNS

All items can be returned for any reason within 30 days of receipt and will receive a full refund as long as the item is returned in its original product packaging and includes all accessories from its original shipment. Once the product has been received by us the refund will be processed within 2 business days. For faster refund, just contact us and provide the return tracking number.

All returns must be shipped back to our warehouse (contact us and get the address) or Amazon warehouse at customer's expense. If the reason for return is a result of an error by us, we will provide a pre-paid shipping label.

PRODUCT WARRANTY

All our Adirondack Chair have a 3-year warranty, during use which we will provide free spare parts if any parts are damaged (but you need to bear reasonable shipping costs)

All parts missing, defective, please contact us before return, we will make everything right for you!



ADIRONDACK
CHAIR

Installation Video 