

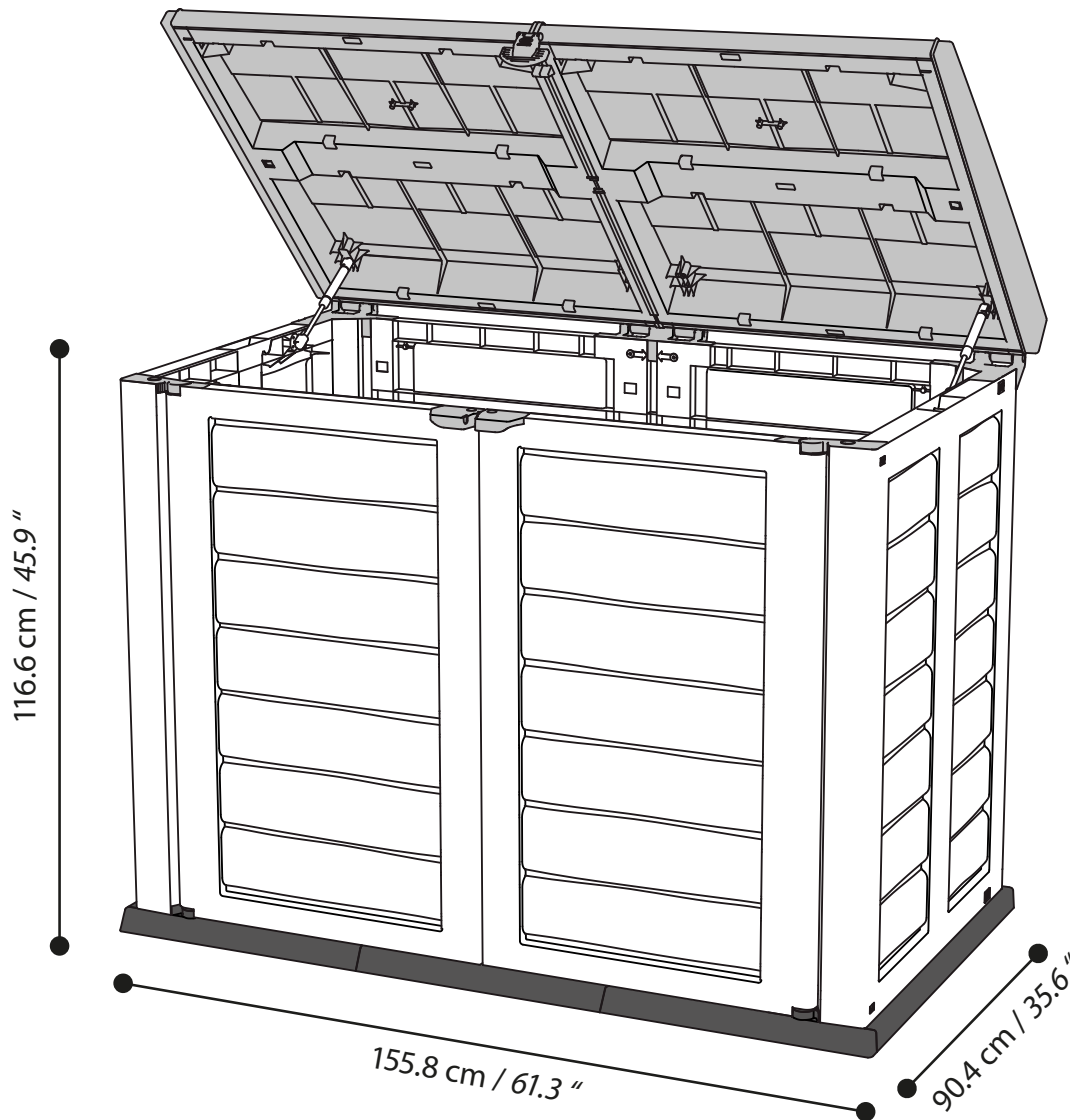

Bodega Mediana de Jardín
Garden Storage Shed
Median Bodega Garden

Geräteschrank STYLE mit pneumatischen Deckelhebern und zwei Türen
Remise de jardin STYLE avec pneumatique lifter du couvercle et deux portes
Magazzino da giardino STYLE con ascensori coperchio pneumatico e due porte



Requiere / Required / Requer / Erforderliches / Nécessaires / Richiesti

INSTRUCCIONES DE ENSAMBLE / ASSEMBLY INSTRUCTIONS / INSTRUÇÕES DE MONTAGEM
MONTAGEANLEITUNG / INSTRUCTIONS DE MONTAGE / ISTRUZIONI DI MONTAGGIO

SIGA TODAS LAS INSTRUCCIONES EN DETALLE / PLEASE FOLLOW ALL INSTRUCTIONS CAREFULLY!
SIGA TODAS AS INSTRUÇÕES DESCRITAS DETALHADAMENTE / FOLGEN SIE GENAU DER ANLEITUNG
SUIVEZ LES INSTRUCTIONS À LA LETTRE / SEGUIRE TUTTE LE ISTRUZIONI IN DETTAGLIO

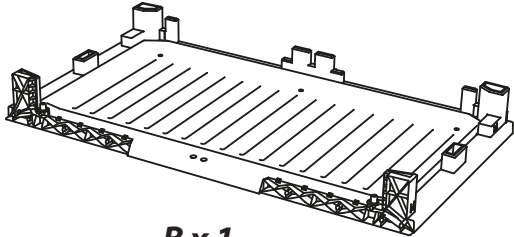
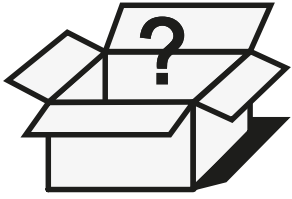

B x 1

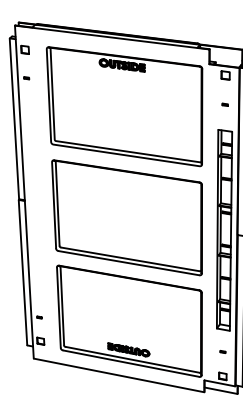

BK x 2

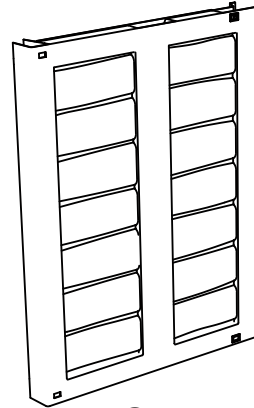

S x 2

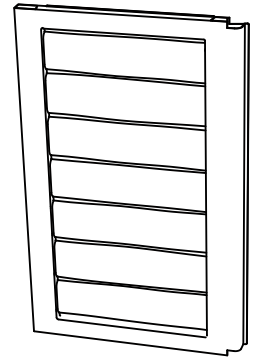

D x 2

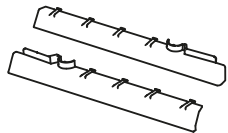

LBC x 1

RBC x 1

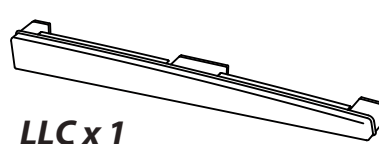

LLC x 1

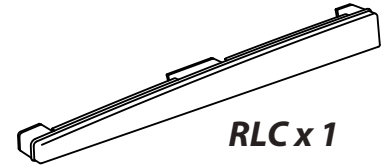

RLC x 1

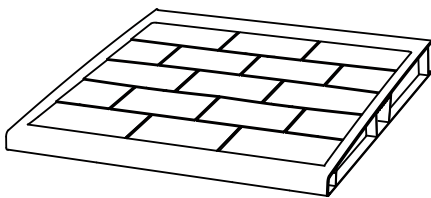

HL x 2

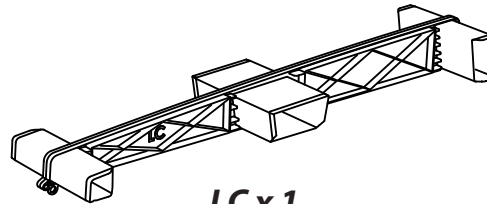

LC x 1

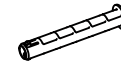

RP x 2

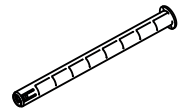

RCP x 1

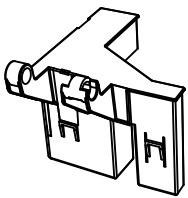

LRH x 1

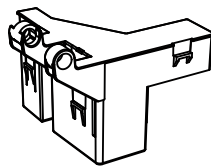

RRH x 1

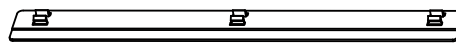

DG x 2

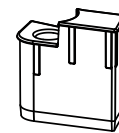

LHT x 2



RHT x 2

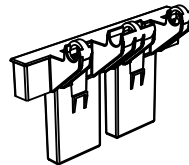

HBS x 1

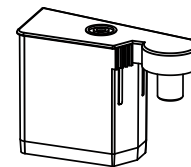

LH x 1



RH x 1

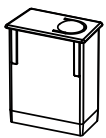

LDB x 1

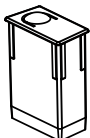

RDB x 1

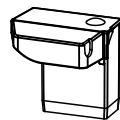

LHH x 1

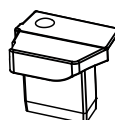

RHH x 1



FLR x 1

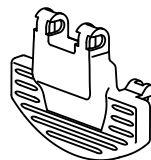

FC x 1

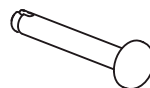

FP x 1

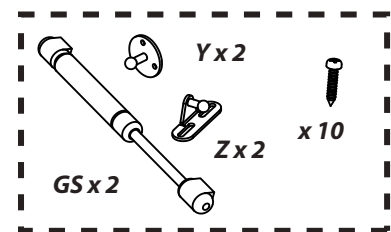

GS x 2

Y x 2

Z x 2

x 10

gas spring x 2

HACER UNA SUPERFICIE A NIVEL ADECUADA / LEVEL A SUITABLE SURFACE
NIVELE UMA ÁREA ADEQUADA PARA A MONTAGEM / PRÉPARER LA SURFACE AU SOL POUR PERMETTRE L'ASSEMBLAGE
EBNEN SIE EINE GEEIGNETE FLÄCHE / LIVELLARE UNA SUPERFICIE IDONEA

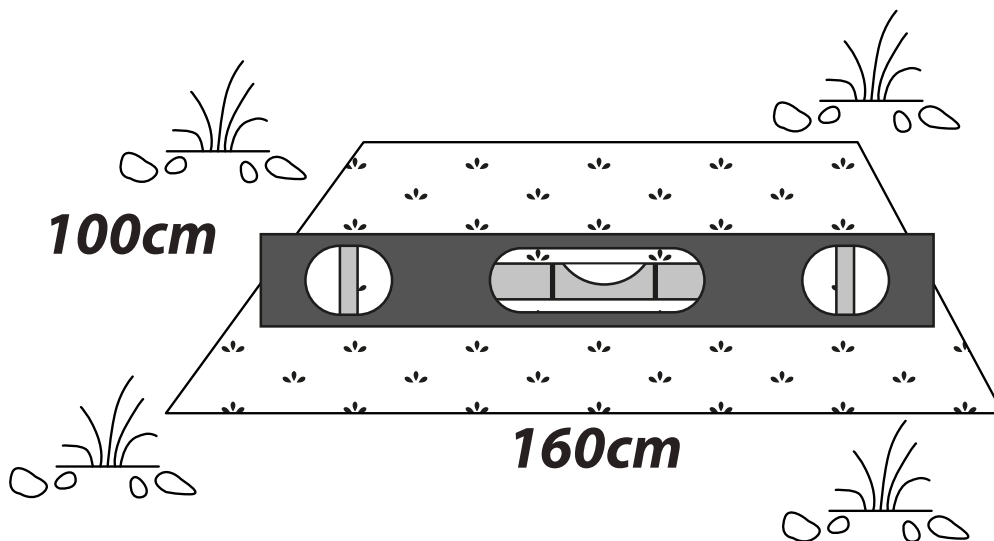

1

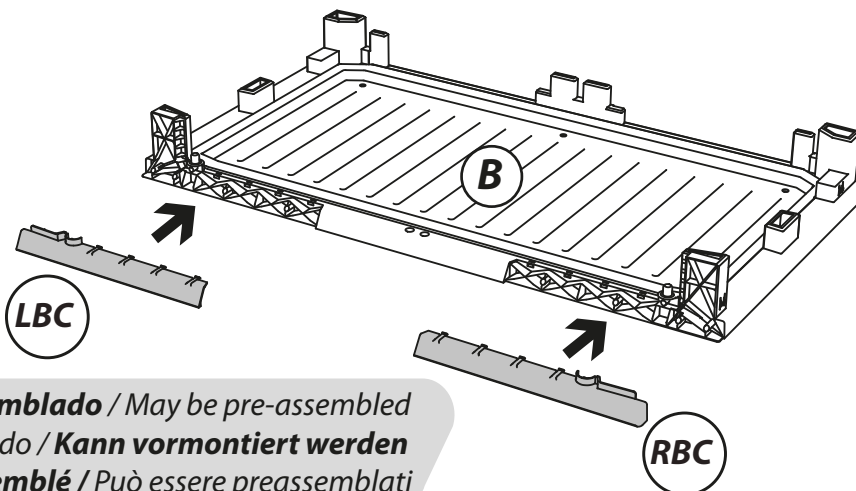

Puede ser preensablado / May be pre-assembled
Pode ser pré-montado / Kann vormontiert werden
Peut être pré - assemblé / Può essere preassemblati

2

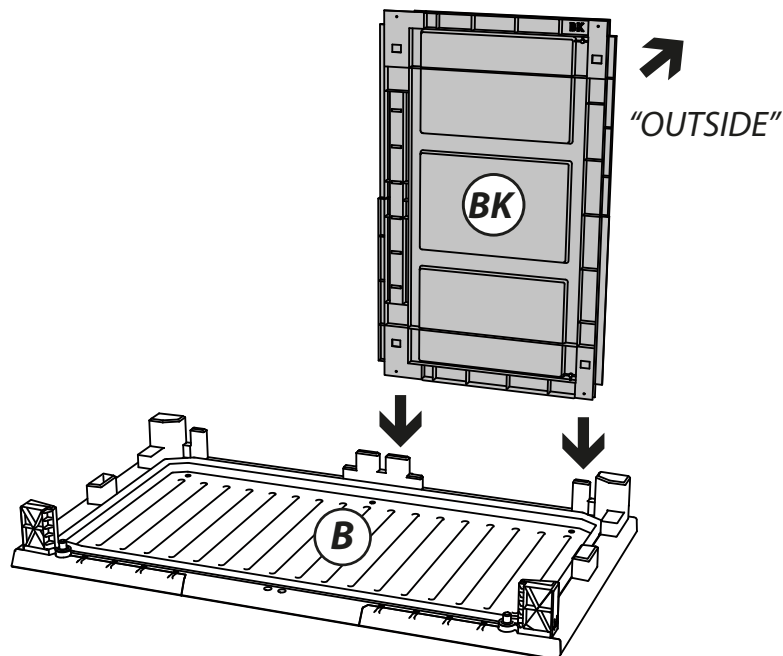

3

3

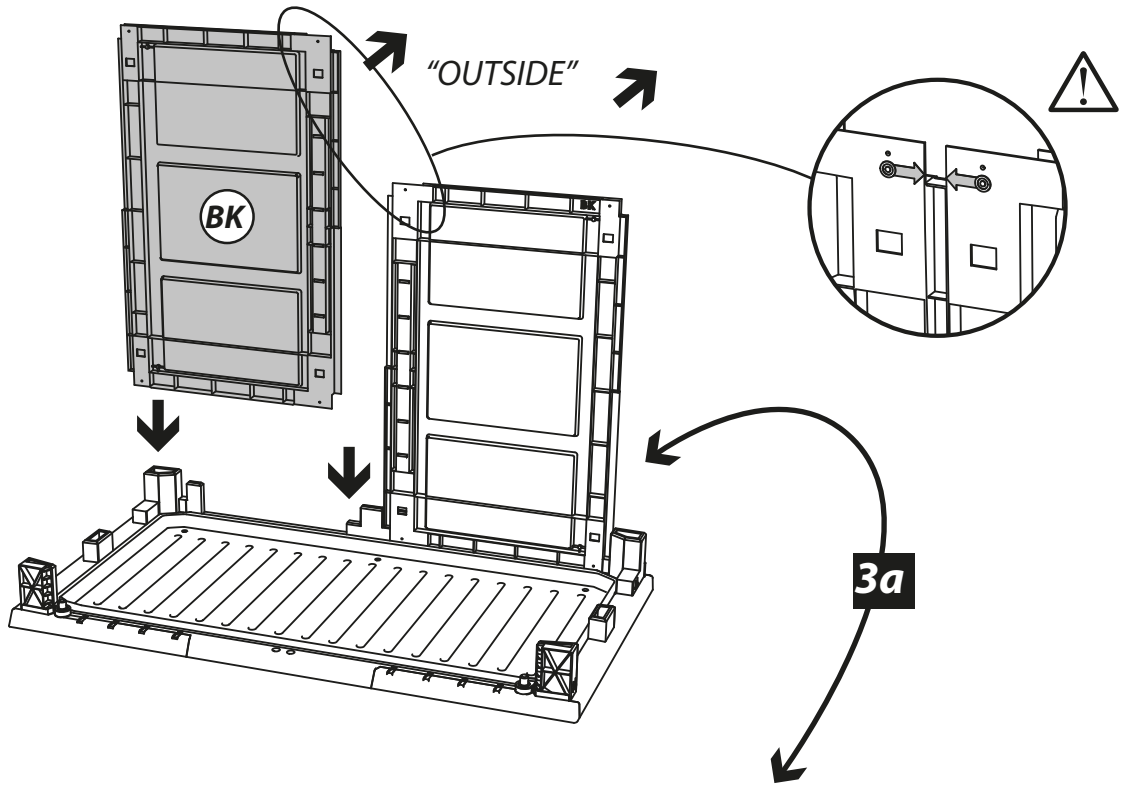

3a

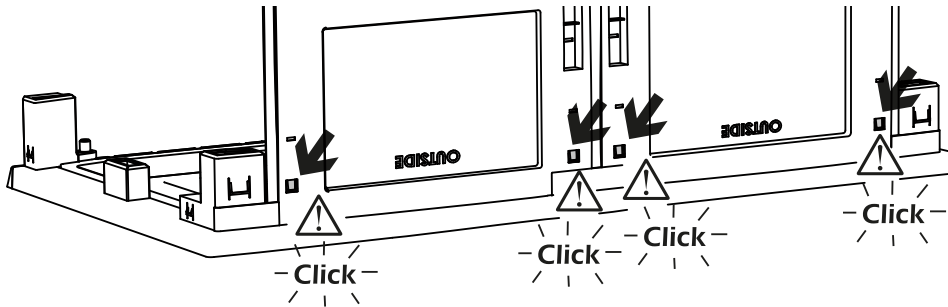

4

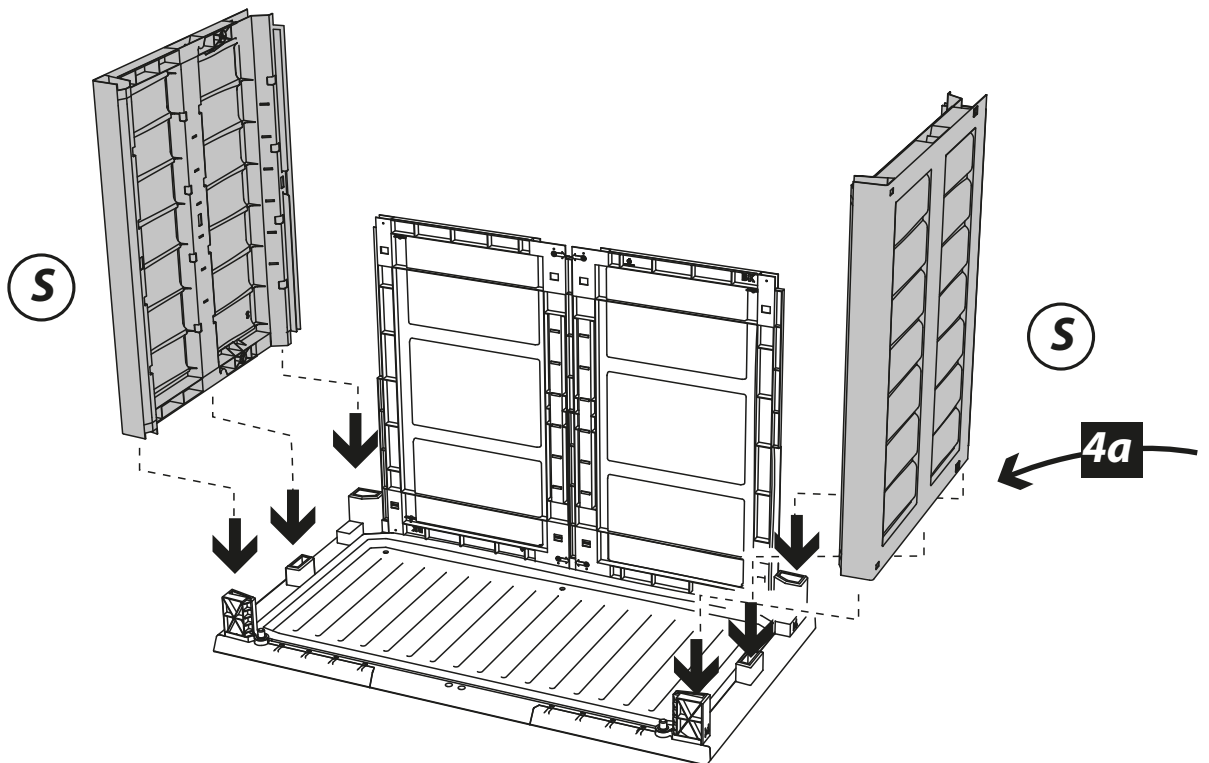

4

4a

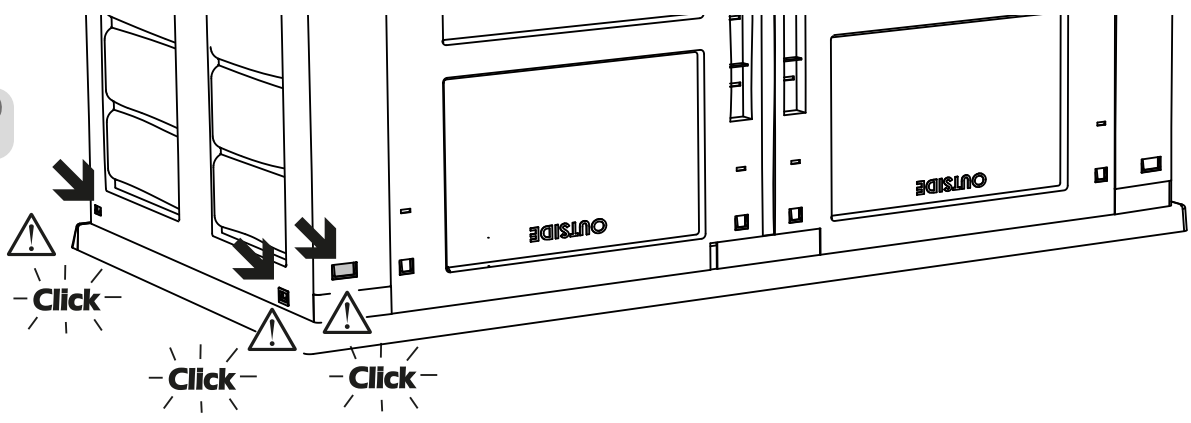

5

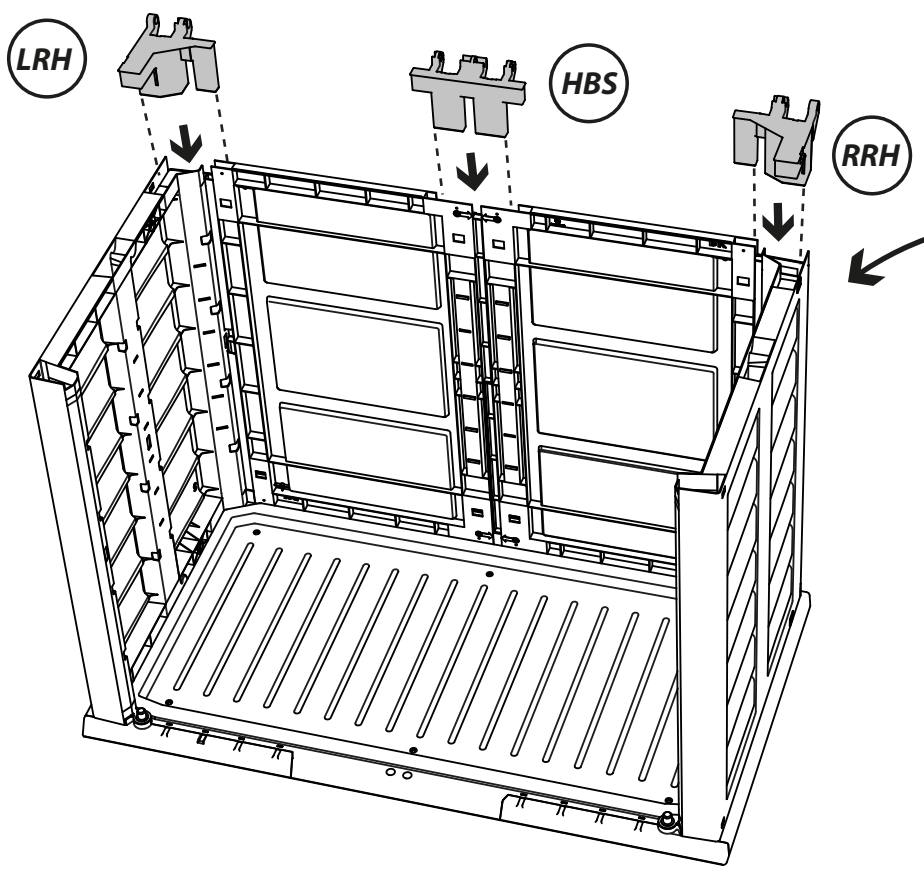

5a

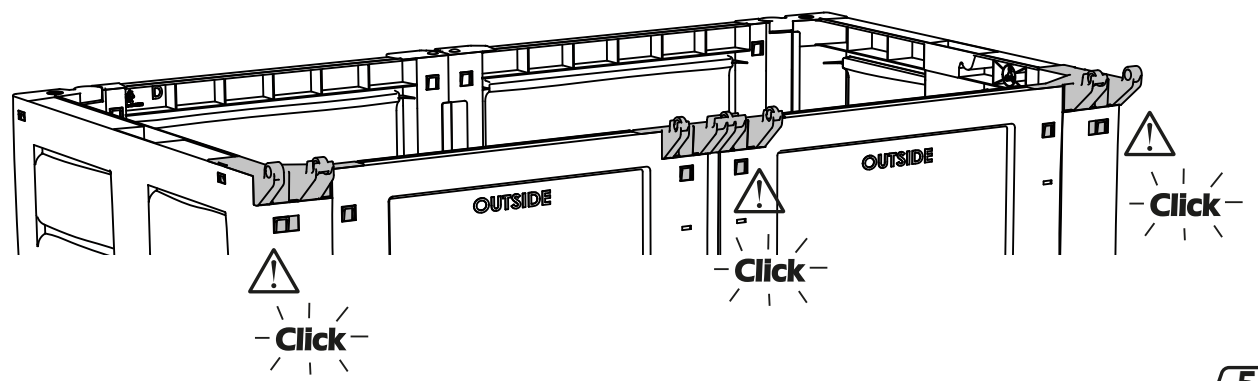

6

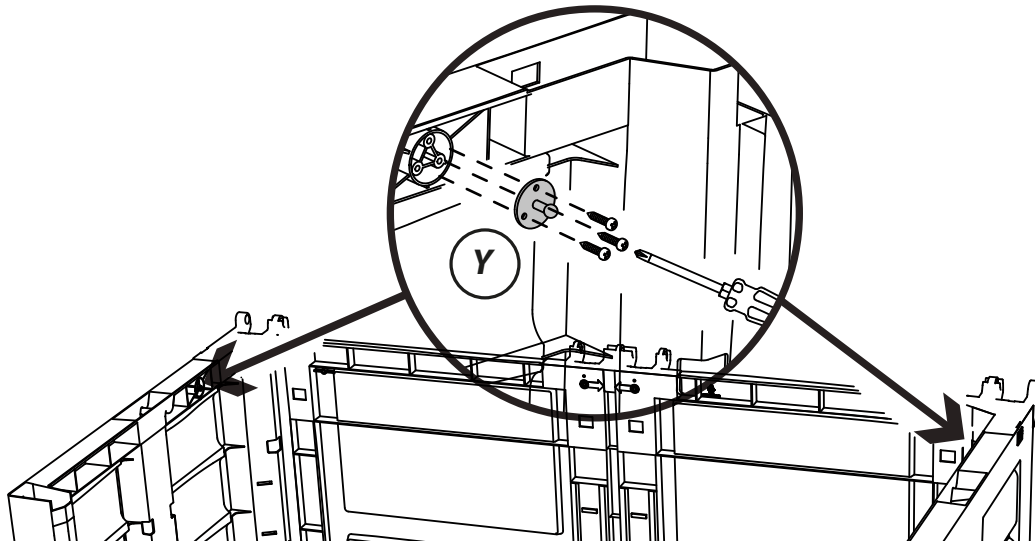

7

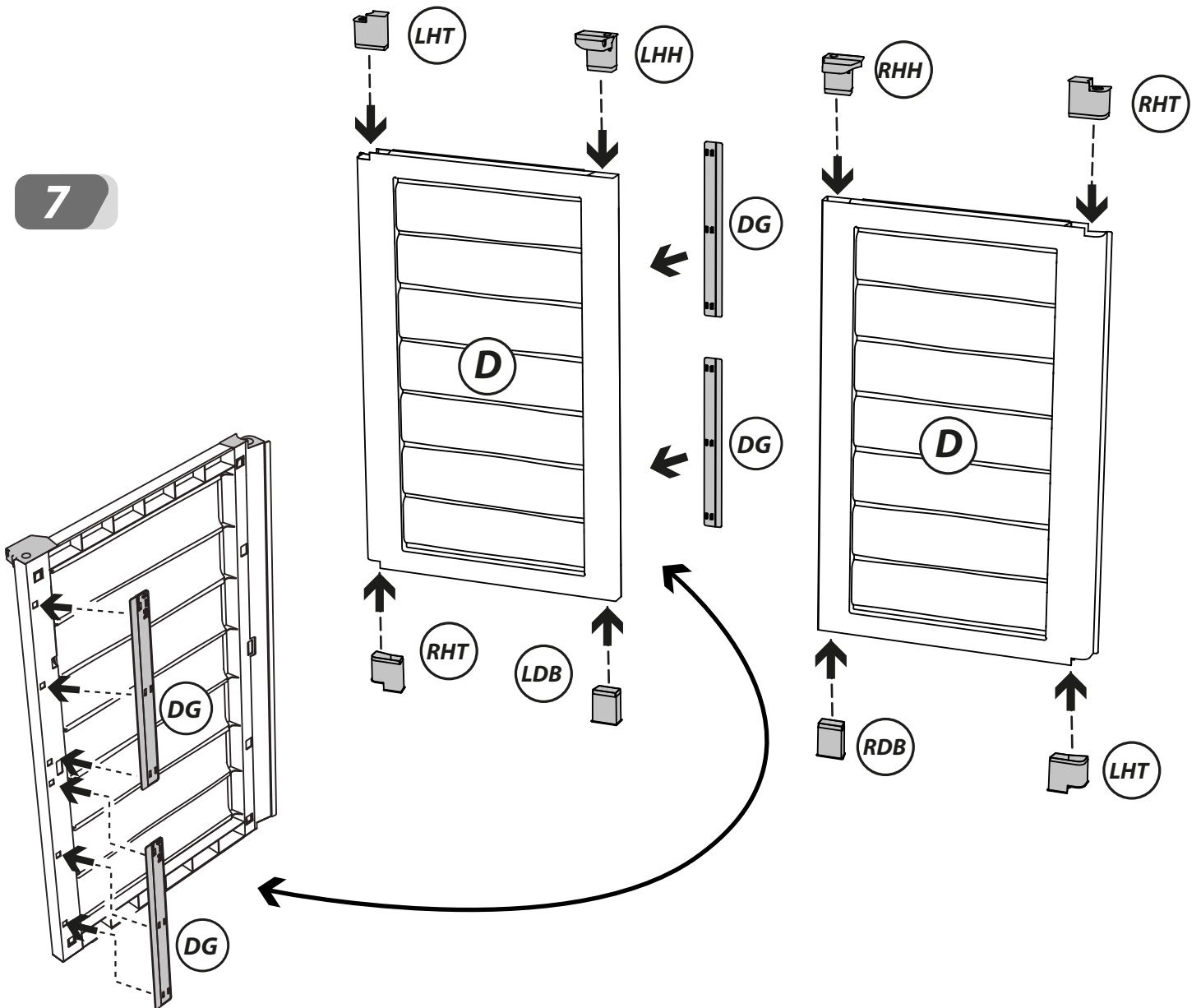

6

LH

8

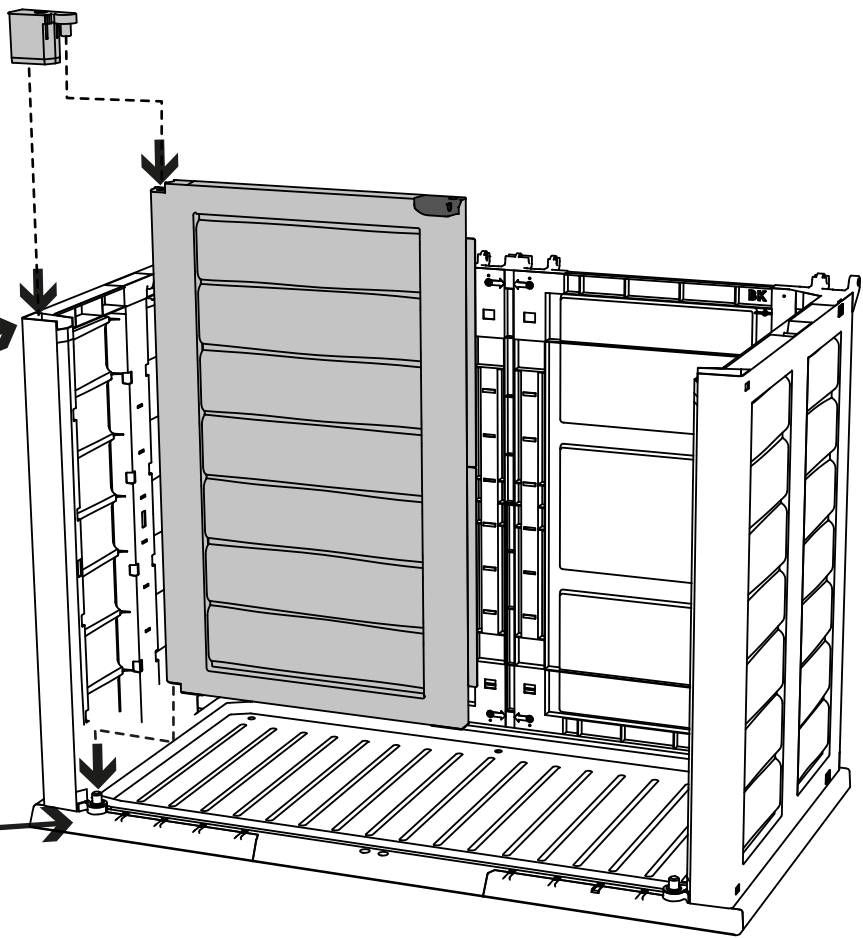
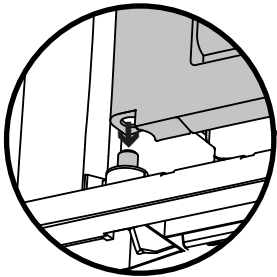
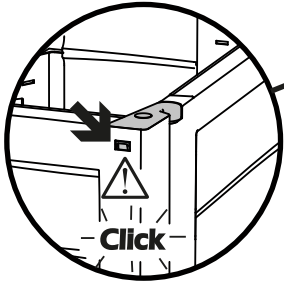

RH

9

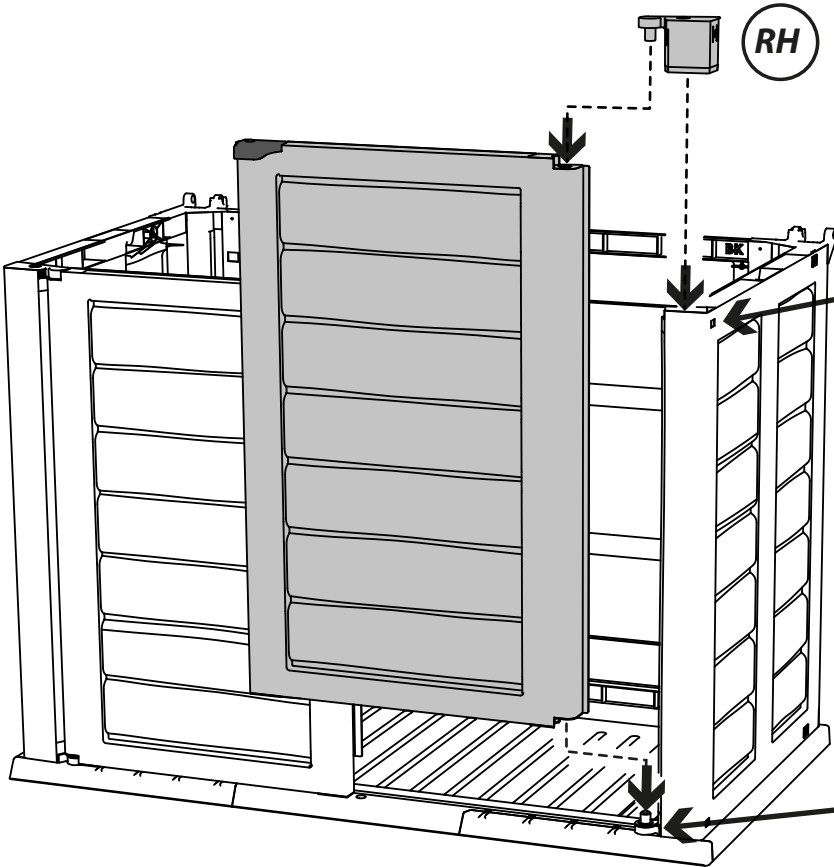
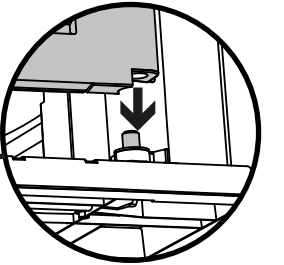
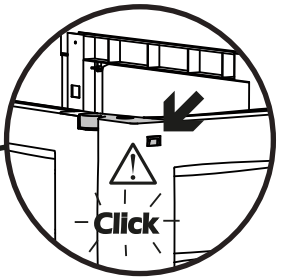

7

10

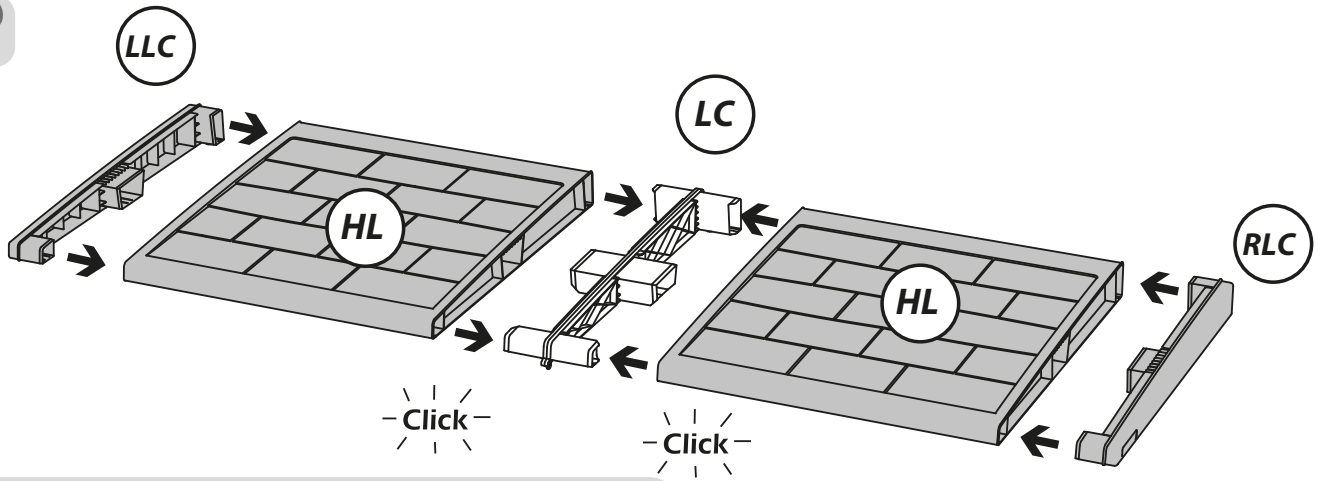

Puede ser preensablado / May be pre-assembled
Pode ser pré-montado / Kann vormontiert werden
Peut être pré - assemblé / Può essere preassemblati

11

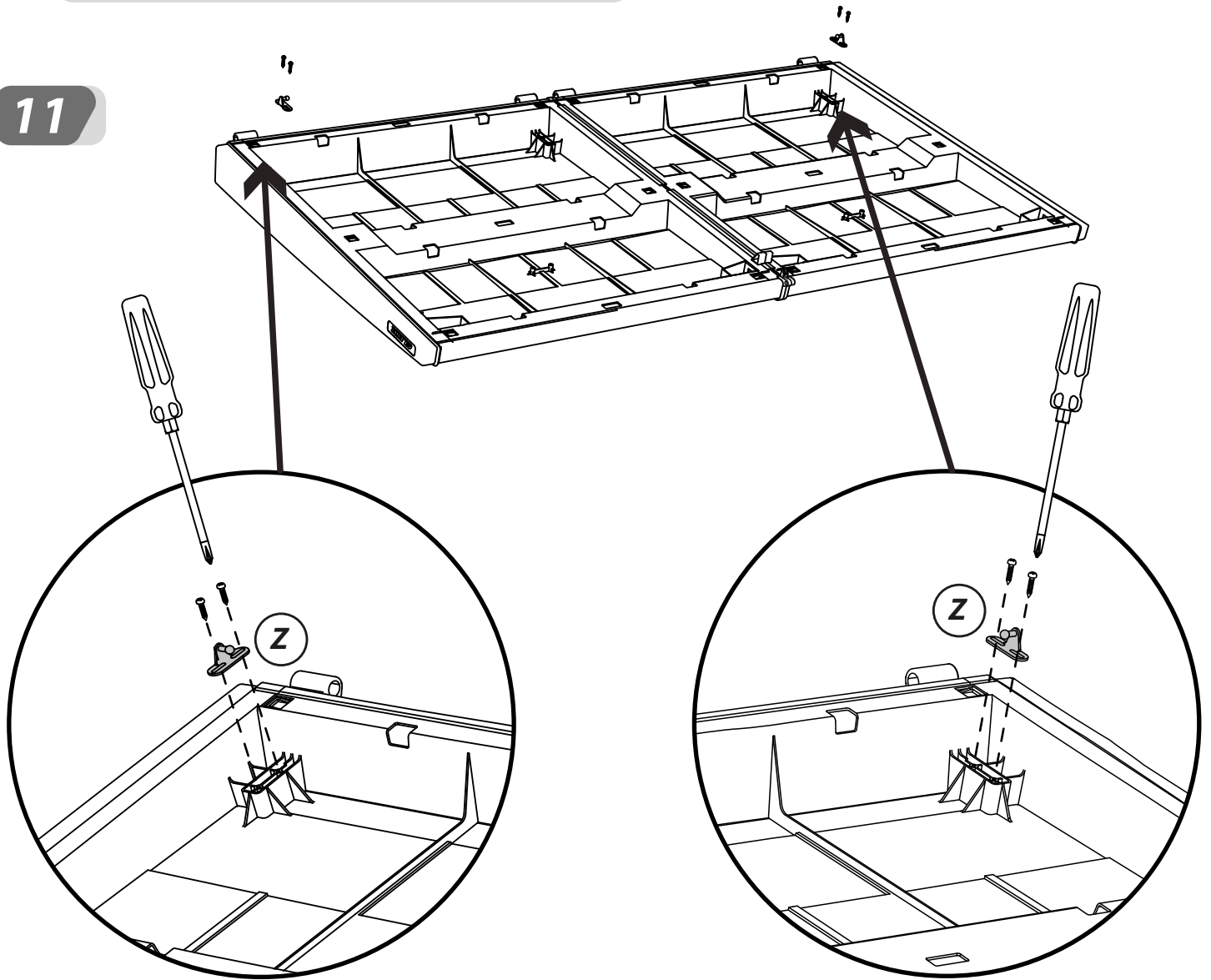

12

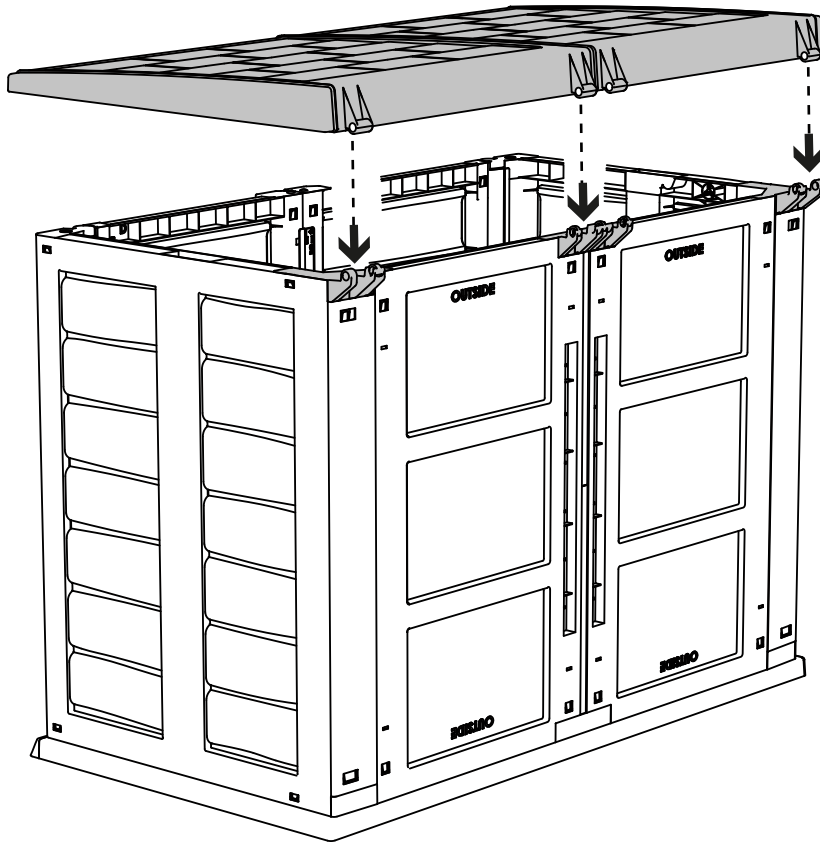

13

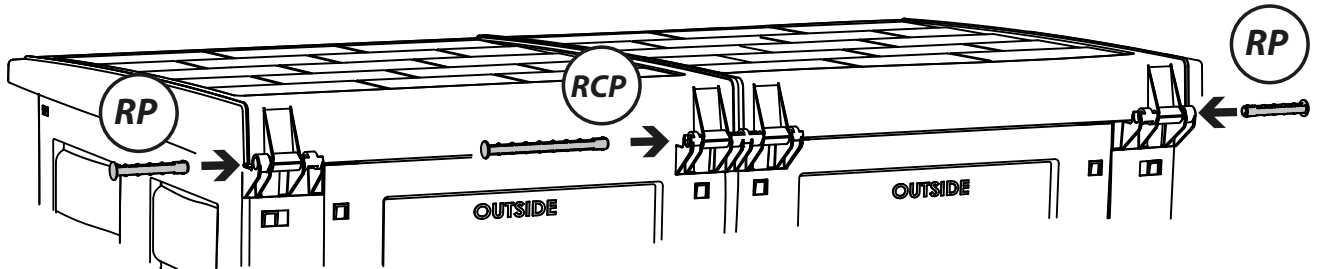

14

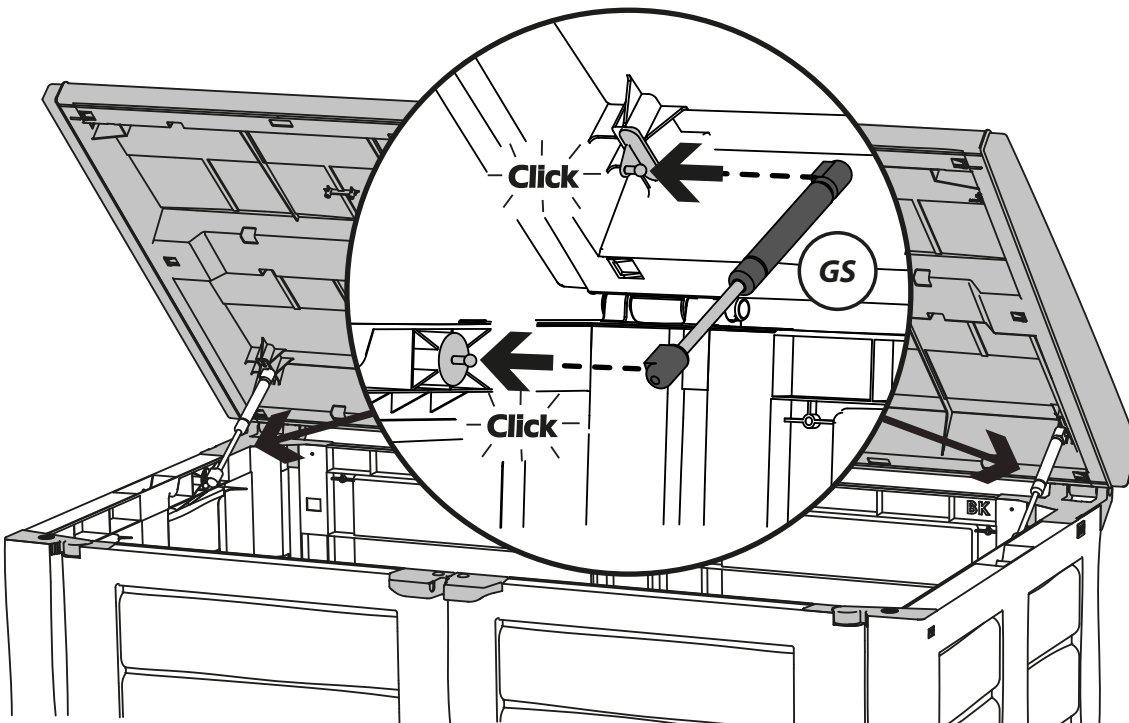

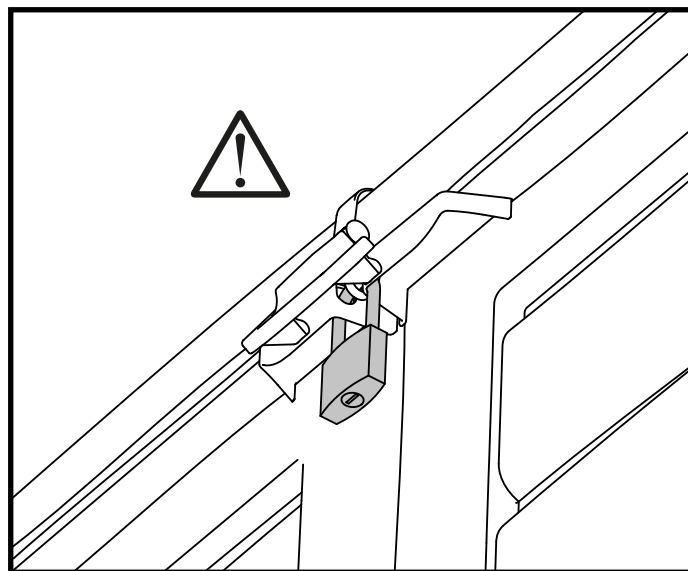
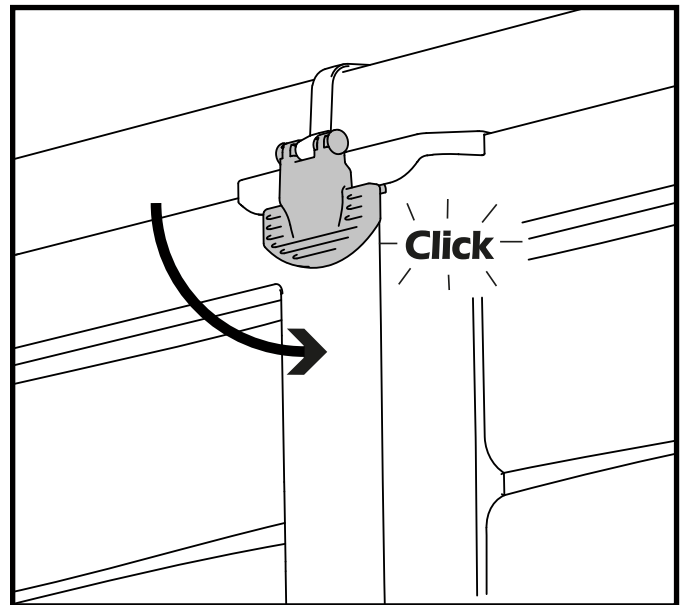
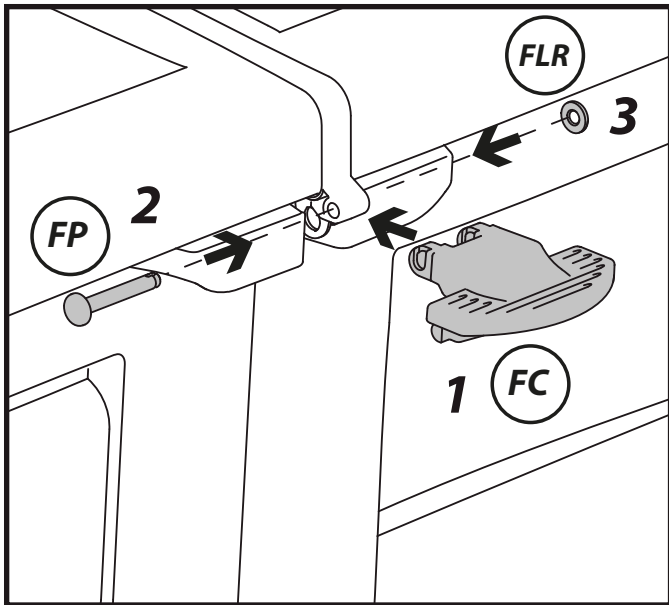

El armario puede ser cerrado con un candado de Ø6mm

Lock the shed with 6 mm (1/4") dia padlock

O abrigo pode ser trancado com um cadeado de Ø6mm

*Zum ordnungsgemäßen Verschließen der Gartengerätebox
benutzen Sie bitte ein Ø6mm Vorhängeschloss*

L'abris peut être verrouillé avec un cadenas Ø6mm

Chiudibile con lucchetto diametro 6mm

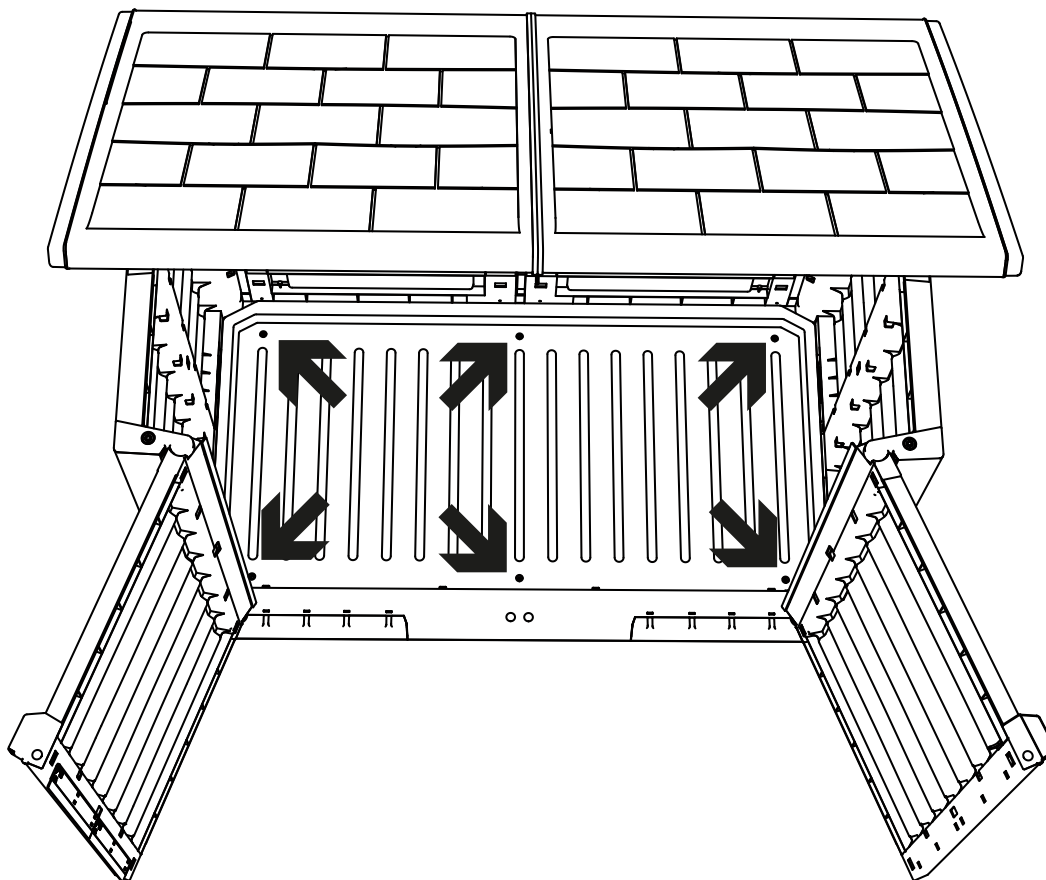

***Para mejorar la estabilidad Recomendamos fijar el armario al piso
(Anclajes no incluidos)***

For improved stability, anchor securely to ground (anchors not provided)

***Para uma melhor estabilidade, recomendamos que o abrigo seja fixado ao chão
E a uma parede. (fixações não fornecidas)***

*Pour garantir une meilleure assise au sol nous conseillons de fixer l'abrisau moyen de sardines
tant au sol (les ancras ne sont pas fournis)*

***Zur gewährleistung zusätzlicher stabilität wird empfohlen den artikel an boden zu verankern
(Materialien zur zusätzlichen stabilisierung sind nicht inbegriffen)***

*Per migliorare la stabilita', fissare la base al suolo tramite Le apposite fessure
(ancoraggi non inclusi)*