

RAILING ASSEMBLY INSTRUCTIONS

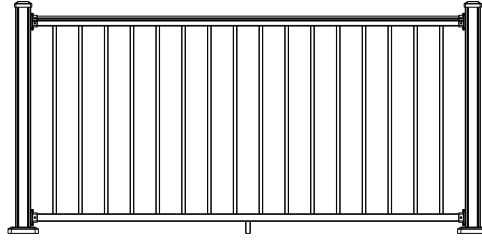

Important

- Consult your local building code official and check all code requirements. Purchaser has the sole responsibility to determine whether the aluminum railing and aluminum post products comply with applicable codes and are appropriate for the intended use. The purchaser and installer should review the intended use of the products with a licensed professional engineer to determine code compliance.
- Obtain all required building permits.
- Read all instructions thoroughly prior to assembly to assure correct installation.
- Manufacturer will not be held responsible for unsafe or incorrect installation.
- Instructions are guides and do not cover every installation scenario.
- Always use fasteners provided in the railing kit.
- Railing has been tested by PEI and meets 2016 IRC Construction Code Standards.
- Applying paint, other than manufacturer's touch up paint, will void warranty.
- Always wear proper safety equipment while assembling and installing.

Included Components:

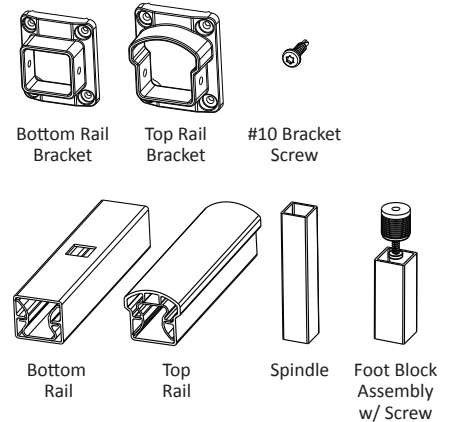

(Post assembly sold separately)

Recommended Tools

Safety Glasses, Tape Measure, Pencil, Saw w/ Fine Tooth Metal Blade, Rubber Mallet, Level, Power Drill, Philips Drive Bit, T25 Torx Drive Bit.

Installation - Straight Railing

Note: Ensure that posts are installed with the 1-piece post skirt in place. Skirt cannot be installed after railing installation. (see Post Instructions)

1. To determine the distance between the posts, measure the length of the rail and add 1/8 inch to that measurement. Note: Adding 1/8 inch will prevent the end of the rails from scratching the posts during installation.
2. Install the foot block on the bottom of the bottom rail with the provided self-drilling screw (*Image 1*). Set the bottom rail on a flat, non-abrasive surface with the spindle holes facing downward. Install the foot block connector with the self-drilling #8 x 7/8" long screw into the middle of the rail. Use a rubber mallet to lightly tap the 2" foot block over the foot block connector until seated. **Note:** the bottom rail needs to be installed 2" from the mounting surface for the foot block to function properly. **Also:** if there is a spindle hole in the center of the bottom rail, the foot block must be centered on that spindle hole so the spindle will not interfere with the foot block screw when assembled.
3. Slide the bottom rail brackets onto the bottom rail (*Image 2*). Place 2" high blocks under the bottom rail for support and proper alignment on each end. Move the bottom rail into position and fasten the self centering bottom rail brackets to the posts using the #10 screws provided. After installing the brackets to the posts, secure the brackets to the bottom rail using the same #10 screws.
4. Insert spindles into each hole in the bottom rail (*Image 3*). Spindles will be easier to install if they are wiggled left to right as they are pushed in. Use a rubber mallet to fully seat the spindles, if needed.
5. Slide the top rail brackets onto the top rail (*Image 4*). Hold the top rail at an angle above the spindles. Start at one end and feed each spindle into the corresponding hole in the top rail. When all of the spindles are in the holes, lightly tap the top of the top rail with a rubber mallet to ensure they are fully seated. Measure to ensure the final top rail height is achieved. Due to variances, you may have to move the top rail up 1/16" to 1/8" to achieve either 36" or 42" distance above the mounting surface.
6. Fasten the self-centering top rail brackets to the posts using the #10 screws provided. Secure the top rail brackets to the top rail with the #10 screws.

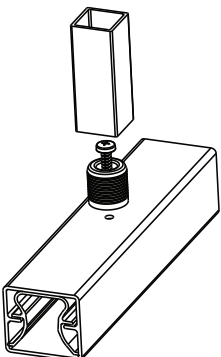

Image 1

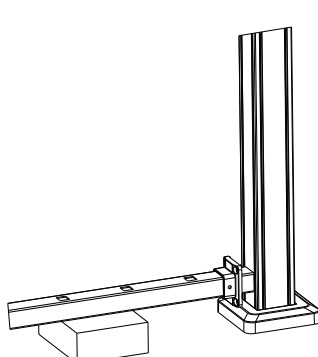

Image 2

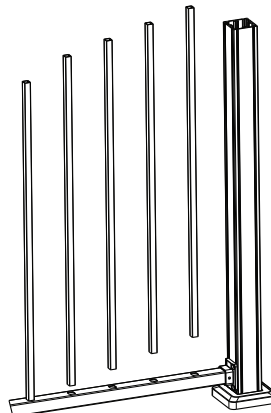

Image 3

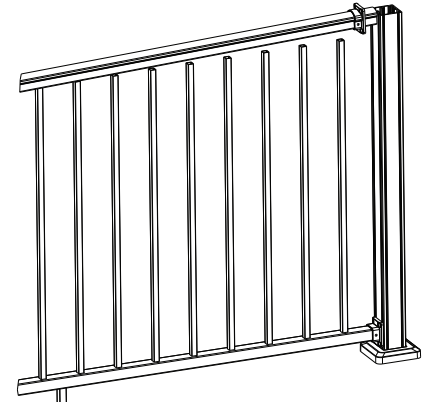

Image 4

We're happy to help! Call (888)743-3673 with questions or concerns.