



SERVICE PARTS LIST

BULLETIN NO.
54-49-2710

SPECIFY CATALOG NO. AND SERIAL NO. WHEN ORDERING PARTS		REVISED BULLETIN	DATE
M18™ FUEL™ STRING TRIMMER			Sept. 2016
CATALOG NO. 2725-20	STARTING SERIAL NO. H35A	WIRING INSTRUCTION See Page 2	

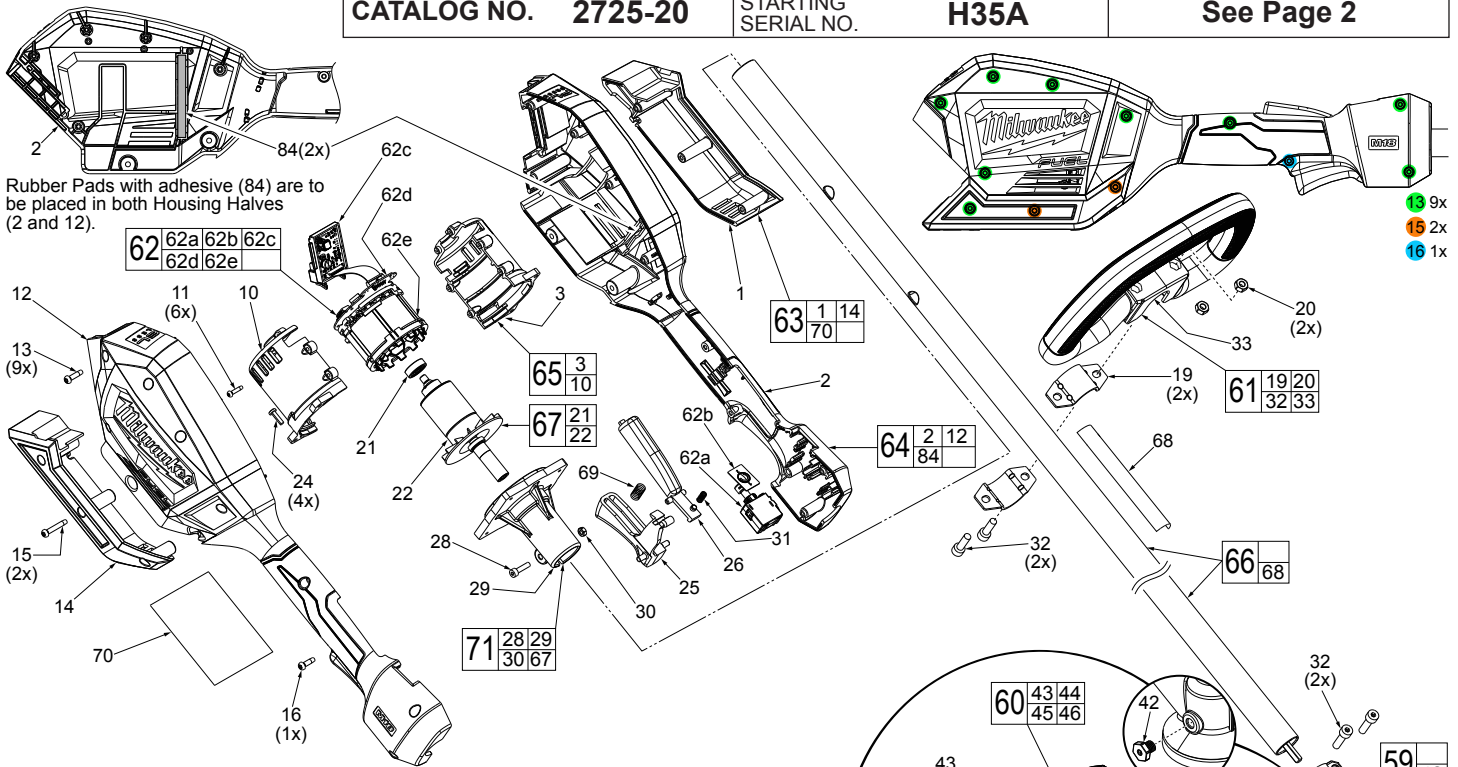

FIG.	PART NO.	DESCRIPTION OF PART	NO. REQ.
1	-----	Lower Cover Halve-Left	1
2	-----	Housing Support-Left Housing Halve	1
3	-----	Motor Insulator-Left	1
10	-----	Motor Insulator-Right	1
11	06-82-1080	M3 x 14mm Pan Hd. ST T-10 Screw	6
12	-----	Housing Cover-Right Housing Halve	1
13	05-88-1200	M4 x 16mm Pan Hd. ST T-20 Screw	9
14	-----	Lower Cover Halve-Right	1
15	05-88-1300	M4 x 28mm Pan Hd. ST T-20 Screw	2
16	05-88-5375	M4 x 13.5 Pan Hd. ST T-20 Screw	1
19	42-68-0292	Carrier Handle Clip	2
20	05-55-0006	M6 Hex Nut	2
21	02-04-0034	Ball Bearing	1
22	-----	Rotor with Drive Shaft Coupling	1
24	06-82-7240	6-19 x 1/2" Pan Hd. ST T-15 Screw	4
25	45-72-0083	On-Off Trigger	1
26	45-72-0084	Release Trigger	1
28	05-74-0013	M4 x 20mm Hex Skt. Hd. Cap Screw (Silver)	1
29	44-34-0095	Motor Mount Assembly with Bearing	1
30	05-55-0004	M4 Hex Nut (Silver)	1
31	40-50-0373	Spring	1
32	05-74-0015	M6 x 21.5mm, 5mm Hex Socket Cap Screw	4
33	-----	Carrier Handle	1
41	05-81-0131	M6 x 18mm, 5mm Hex Flat Hd. Screw	1
42	05-85-0080	M8 x 1.25 Hex Hd. Screw	1
43	-----	String Guard	1
44	42-26-0024	Line Cut-Off Blade	1
45	05-74-0935	M5 x 15mm Pan Hd. T-25 Machine Screw	2
46	05-81-0132	M6 x 14mm Pan Hd. T-30 Machine Screw	4
52	44-66-0029	Lock Plate Assembly	1
53	-----	Trimmer Head Body	1
54	-----	Trimmer Head Spring	1
55	-----	Spool and Bump Knob	1
56	-----	0.080" x 150' String	1
57	-----	Trimmer Head Cover	1
58	-----	Guideline Eyelets	2
59	14-30-0205	Gearcase Assembly	1
60	14-32-0140	String Guard Assembly	1
61	14-34-0124	Carrier Handle Assembly	1
62	14-20-0056	Electronics Assembly	1
62a	-----	On-Off Switch	1
62b	-----	Two Speed Selector/PCBA Assembly	1
62c	-----	Battery Connector/PCBA Assembly	1
62d	-----	Hall Board Assembly	1
62e	-----	Stator Assembly	1
63	31-44-0181	Lower Cover Kit	1
64	31-44-0182	Housing Kit	1

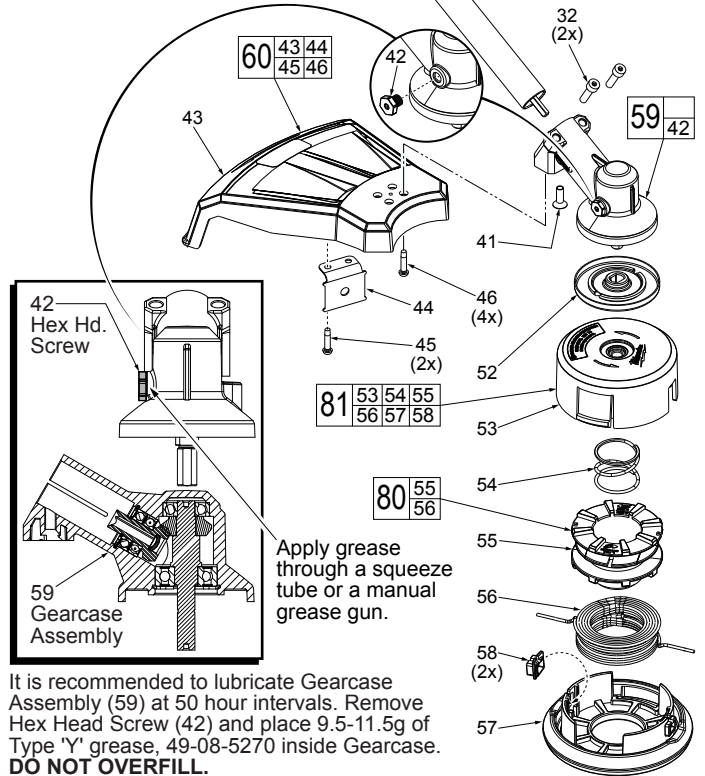
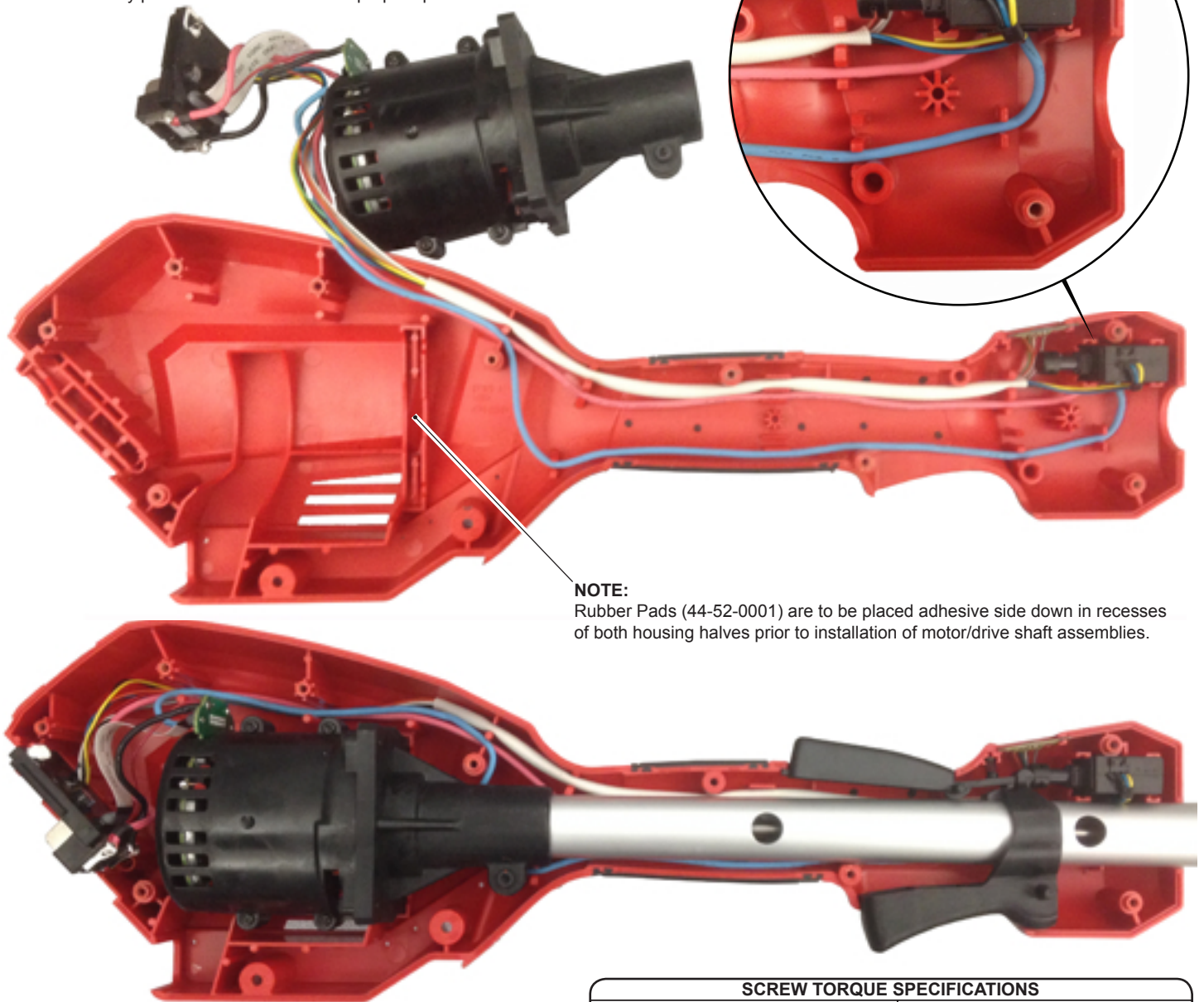

FIG.	PART NO.	DESCRIPTION OF PART	NO. REQ.
65	31-50-0881	Motor Insulator Kit	1
66	45-08-0174	Drive Shaft Assembly	1
67	16-01-0021	Rotor Assembly	1
68	10-20-1043	Warning Label	1
69	40-50-0374	Bias Spring	1
70	12-20-0088	Service Nameplate	1
71	14-50-2725	Rotor/Motor Mount Assembly	1
80	49-16-2711	Loaded Replacement Spool	1
81	49-16-2710	Loaded Replacement Head	1
82	49-96-0012	5mm Hex Key (Not Shown)	1
83	49-96-0055	T-30 Key (Not Shown)	1
84	44-52-0001	Rubber Pad with Adhesive (Set of 2)	1

WIRING INSTRUCTION

- Place On-Off Switch (62a) and Two Speed Selector PCBA (62b) squarely and firmly in the cavities of the Support Housing (2).
- Route wires from those components through the wire traps in the Support Housing, removing as much slack in the wires along the way.
- The Rotor/Stator Assemblies (62d, 62e, 67) are captured in the Motor Insulator/Motor Mount Assemblies (65, 71). Place these components squarely and firmly in the cavities of the Support Housing.
- Route wires from those components through wire traps in the Support Housing, removing as much slack in the wires along the way.
- Place Battery Connector/PCBA squarely and firmly in the cavity of the Support Housing.
- Be sure to tuck all wires and sleeved wire assemblies to the bottom of all wire traps.
- Carefully insert Drive Shaft Assembly (66) into the Rotor/Motor Mount Assembly (71). Be sure to orient Drive Shaft so the two holes are perpendicular to the Support Housing. Tighten Hex Screw (28) with a 3mm hex wrench to secure Drive Shaft to Motor Mount.
- Reinstall On-Off Trigger (25), Release Trigger (26) and Release Trigger Spring (31).
- Carefully place Housing Cover (12) onto Housing Support being sure to check for any interference and secure with Screws (13).
- Attach the Lower Cover Halves (63) with Screws (15).
- Check for the proper functionality of the On-Off Trigger (25) and Release Trigger (26).
- Install a battery pack and check the tool for proper operation.



NOTE:

Rubber Pads (44-52-0001) are to be placed adhesive side down in recesses of both housing halves prior to installation of motor/drive shaft assemblies.

**ALWAYS REMOVE BATTERY PACK
BEFORE PERFORMING ANY
MAINTENANCE OR REPAIRS**

SCREW TORQUE SPECIFICATIONS			SEAT TORQUE	
FIG.	PART NO.	WHERE USED	(KG/CM)	(IN/LBS)
11	06-82-1080	Motor Insulator	12.0-16.0	10.4-13.8
13	05-88-1200	Housing Cover	15.0-20.0	13.0-17.3
15	05-88-1300	Lower Cover	15.0-20.0	13.0-17.3
16	05-88-5375	Housing Cover	15.0-20.0	13.0-17.3
24	06-82-7240	Motor Insulator	12.0-16.0	10.4-13.8
28	05-74-0013	Motor Mount	11.0-14.0	9.5-12.1
32	05-74-0015	Carrier Handle	25.0-28.0	21.6-24.3
32	05-74-0015	Gearcase Assy.	25.0-28.0	21.6-24.3
41	05-81-0131	Gearcase Assy.	20.0-25.0	17.3-21.6
42	05-85-0080	Gearcase Assy.		
45	05-74-0935	Line Cut-Off Blade	15.0-20.0	13.0-17.3
46	05-81-0132	String Guard Assy.	28.0-32.0	24.3-27.7
53	-----	Trimmer Head	145-155	125.8-134.5