

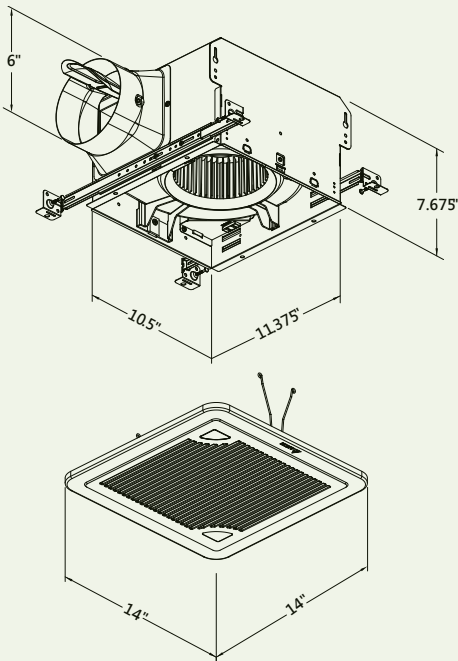

# Delta BreezSmart Ventilation Single Speed Fan Specifications

SMT150  
(150CFM)

## Dimensions



## Description

Low noise ceiling mount ventilating fan rated for continuous running. has been awarded ENERGY STAR® Most Efficient in 2013. It is HVI, UL, and cUL certified, and can be used to comply with ASHRAE 62.2 (local and whole building continuous and intermittent operation), CA Title 24, and CALGreen requirements.

## Motor/Blower

- Power rating of 120volts/60Hz
- DC brushless motor engineered to run continuously
- Motor equipped with thermal cutoff fuse
- Removable with permanently lubricated plug-in motor

## Housing

- Galvanized steel body
- Detachable 6" diameter metal duct adapter
- Built-in backdraft damper
- Easy installation with expandable extension bracket

## Grille

- Attractive design using ABS material
- Attaches directly to housing with torsion springs

## Warranty

- 3-year limited warranty

## Features

- For ceiling mount only, airflow of 150 CFM ( $\pm 10\%$ ), and  $< 0.3$  sones at  $0.1''$  static pressure
- Power consumption approximately 16.9 Watts with an efficiency rating approximately 8.8 CFM/Watt at  $0.1''$  static pressure
- UL and cUL listed for tub/shower enclosure when used with GFCI-protected branch circuit wiring

## DC Motor Technology

- Built-in soft start function to increase bearings' life
- Automatically powers off when the impeller is locked abnormally

## Specifications

SMT150	6" Duct (Standard)	
Static Pressure (Inches w.g.)	0.1	0.25
Air Flow (CFM)	150	149
Sones	<0.3	1.0
Power Consumption (Watts)	16.9	23.7
Energy Efficiency (CFM/Watt)	8.8	6.2
Current (Amps)	0.47 Max	
Power Rating (V/Hz)	120/60	

