

DVG50R5400V

SAMSUNG

Samsung Top Load Gas Dryer with Steam Sanitize+

7.4 cu. ft. Capacity DOE



Signature Features

Steam Sanitize+

- The Steam Sanitize+ cycle removes 99.9% of germs and bacteria, over 95% of pollen, and kills 100% of dust mites.¹ Multi-Steam Technology steams away wrinkles, odors, and static.

Sensor Dry

- Automatically optimizes the time and temperature of your drying cycle to protect your clothes from heat damage, while avoiding excessive energy use.

12 Preset Drying Cycles

- More cycles to cover almost every drying need for your active family.

Available Colors

 Fingerprint Resistant
Black Stainless Steel (shown)

 White



Steam Sanitize+



Sensor Dry

Features

- Steam Sanitize+
- Sensor Dry
- 12 Preset Drying Cycles
- Smart Care
- 9 Additional Drying Options
- Interior Drum Light
- 3-Way Venting
- Powder Coat Interior
- 5 Temperature Levels
- 7.4 cu. ft. Capacity
- Reversible Tinted Door
- LED Display: Ice Blue

Convenience

- Child Lock
- Lint Filter Indicator

¹Based on internal testing and independently verified by Intertek. Individual results may vary.

DVG50R5400V

SAMSUNG

Samsung Top Load Gas Dryer with Steam Sanitize+

7.4 cu. ft. Capacity DOE

Installation Specifications

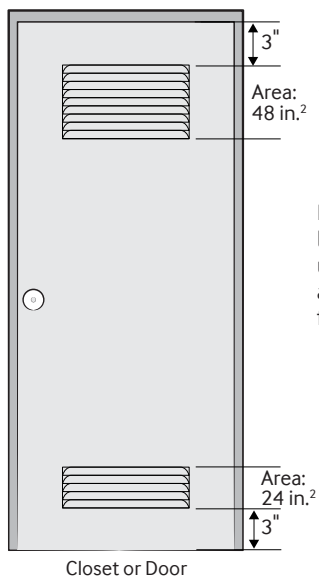
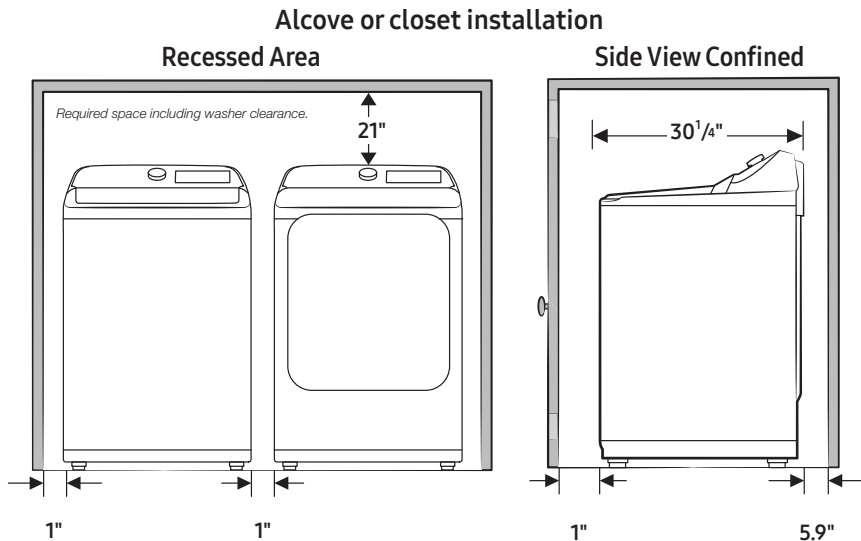

Minimum clearances for closets and alcoves:

- Sides – 1"
- Top – 21"
- Rear – 5.9"
- Closet Front – 1"

If both the washer and a dryer are installed in the same location, the front of the alcove or closet must have two unobstructed air openings for a combined minimum total area of 72-inch². This clearance requirement is applicable for washers only.

Dimensions

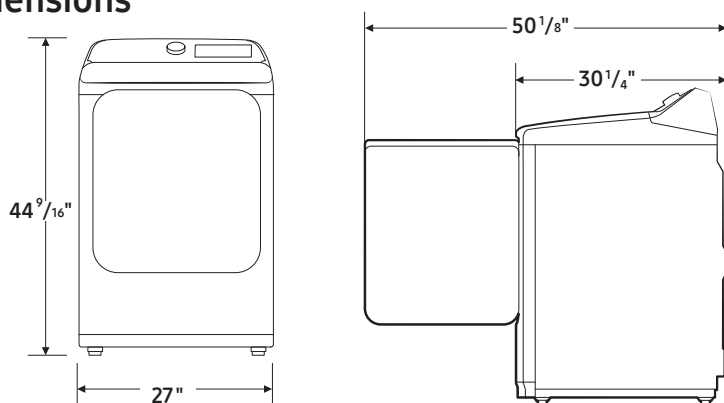

3-Way Venting

12 Preset Drying Cycles:

Refresh, Steam Sanitize+, Wrinkle Away, Normal, Heavy Duty, Permanent Press, Bedding, Delicates, Activewear, Time Dry, Air Fluff, Quick Dry

9 Additional Drying Options:

Damp Alert, Wrinkle Prevent, Adjust Time (Up), Adjust Time (Down), Child Lock, Alarm Off, Eco Dry, Smart Care, Drum Light

5 Temperature Levels:

High, Medium High, Medium, Medium Low, Low

5 Dry Levels:

More Dry, Normal-More Dry, Normal Dry, Normal-Less Dry, Less Dry

Warranty

One (1) Year Parts and Labor

Product Dimensions & Weight (WxHxD)

Dimensions: 27" x 44 9/16" x 30 1/4"
Weight: 119.0 lbs

Shipping Dimensions & Weight (WxHxD)

Dimensions: 29 9/16" x 46 15/16" x 31 3/16"
Weight: 125.7 lbs

Gas

Fingerprint Resistant
Black Stainless Steel
White

Model

DVG50R5400V
DVG50R5400W

UPC Code

887276300771
887276300788

Electric

Fingerprint Resistant
Black Stainless Steel
White

DVE50R5400V
DVE50R5400W

887276300740
887276300757

Matching Washer

Fingerprint Resistant
Black Stainless Steel
White

WA50R5400AV
WA50R5400AW

887276300535
887276300542

Accessories

Vent Kit

DV-2A

887276146416