



MODEL ELT80-110DLED

(Fan/Dimmable LED Light with Dual Speed 80/110 CFM)



Full Speed:

80 CFM/0.5 Sones @ 0.1" SP, 7 Watts
59 CFM/0.9 Sones @ 0.25" SP, 9 Watts

Full Speed:

110 CFM/0.7 Sones @ 0.1" SP, 10.3 Watts
89 CFM/1.0 Sones @ 0.25" SP, 13 Watts



Most Efficient 2019
www.energystar.gov



Description

Low noise ceiling mount ventilating fan with dual speed rated for continuous running. Fan has been awarded ENERGY STAR Most Efficient 2019. It is HVI, UL, and cUL certified to comply with ASHRAE 62.2 local and whole building continuous and intermittent operation. Meets CA Title 24.

DC Motor/Blower

- Power Rating of 120 volts/60Hz
- Motor equipped with thermal cutoff fuse
- Removable with permanently lubricated plug-in motor
- Full speed adjustable, 80 or 110 CFM
- For humidity control mode, when humidity is above the user-adjustable set-point, fan runs at full speed. When humidity is below the set-point, the fan runs continuously at a pre-set For continuous low speed mode, the fan runs continuously at a user-preset lower level (0, 50, 80 CFM)
- Adjustable humidity set points between ~50% to ~80% RH
- Built-in soft start function to increase bearings' life
- Automatically powers OFF when impeller is locked abnormally

Housing

- Galvanized steel body
- Detachable 6" diameter duct adapter
- Includes 6" to 4" duct reducer
- Built-in backdraft damper
- Easy installation with expandable extension bracket and foldable mounting bracket

Grille

- Attractive design using ABS material
- Attaches directly to housing with torsion springs

Light

- 13-Watt LED Light output 850 Lumens, 3000K, 90CRI
- Dimmable Lighting (dimmable switch not included)

LED Indicator

- Green and amber LED indicator lights show continuous low speed and full speed modes

Warranty

- 3-Year limited warranty

TYPICAL SPECIFICATION

Ventilation fan shall be Delta Breez model ELT80-110DLED; ENERGY STAR qualified with Brushless DC Motor engineered to run continuously for a minimum 70,000 hours; airflow rating of 110 CFM and loudness rating of 0.7 Sones at 0.1 static pressure as certified by the Home Ventilating Institute (HVI); power consumption of 10.3 Watts with efficiency rating of 10.6 CFM/Watt at 0.1" static pressure; fan will feature motor lock protection and self-compensating motor speed for intended airflow when static pressure is encountered. UL and cUL listed for tub/shower enclosure when used with GFCI-protected branch circuit wiring.

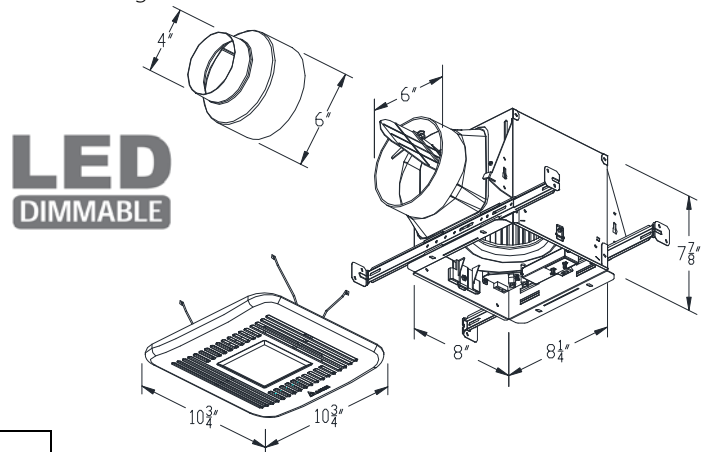

BreezElite ELT80-110DLED								
Fan Speed	Continuous low speed				Full speed			
Static Pressure (inches w.g.)	0.1	0.25	0.1	0.25	0.1	0.25	0.1	0.25
Air Flow (CFM)	50	35	80	59	80	59	110	89
Sones	0.3	0.8	0.5	0.9	0.5	0.9	0.7	1.0
Power Consumption (Watts)	5	6	7	9	7	9	10.3	13
Energy Efficiency (CFM/Watts)	10.0	5.8	11.4	6.5	11.4	6.5	10.6	6.8
Current (Amps)	0.28 Max.							
Power Rating (V/Hz)	120 / 60							
Dimmable LED Light (Watts)	13							

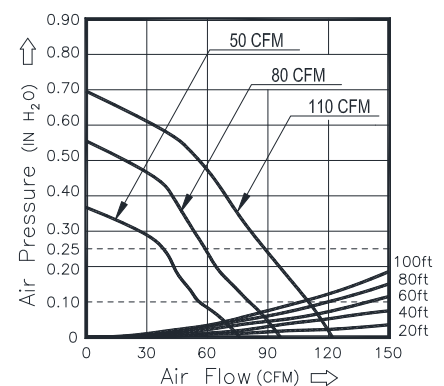
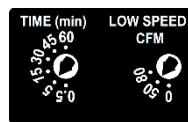

Model	Quantity	Comments	Project:
			Location:
			Architect:
			Engineer:
			Contractor:
			Submitted by:
			Date:

