

1" Energy Saving Rod Installation Instructions

-----Please read all Instruction before starting.

Tools Required:

- Drill with 3/16" (0.5cm) drill bit
- Philips head screw driver
- Level

Parts List

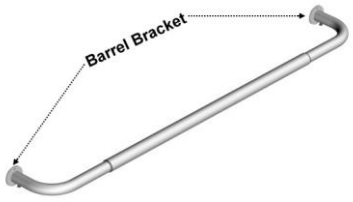
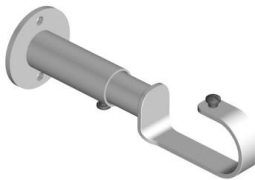
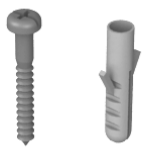
| | | |
|--|---|---|
|  |  |  |
| <p>I. 3 pcs telescopic pipe set with 2 Barrel Brackets. 2 side L pipes adjust from center pipe.</p> | <p>II. Center Support Bracket for 48"-84" 52"-96" 84"-120" and 96"-144".</p> | <p>III. Wall Mounting Anchors and Screws 28"-48" or 30" - 52" 4 Anchors & 4 Screws 48"-84" or 52" - 96" 6 Anchors & 6 Screws 84"-120" or 96"-144" 6 Anchors & 6 Screws</p> |

Bracket Instructions

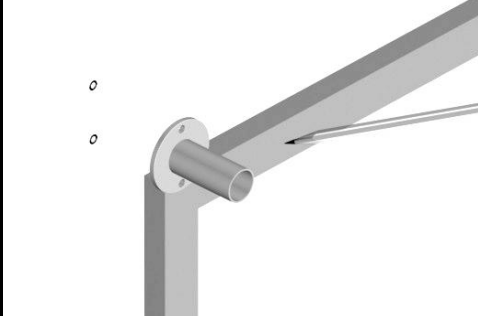
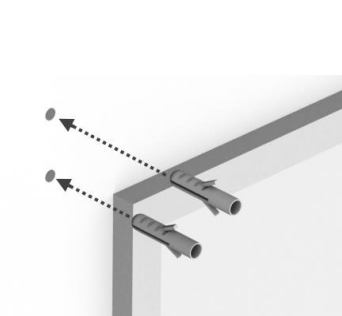
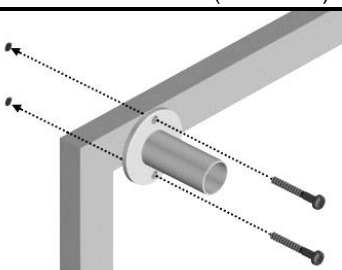
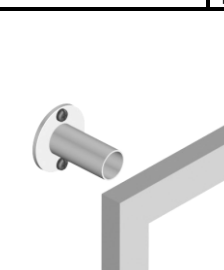
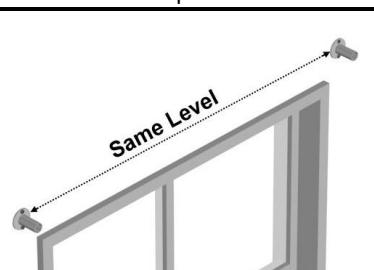
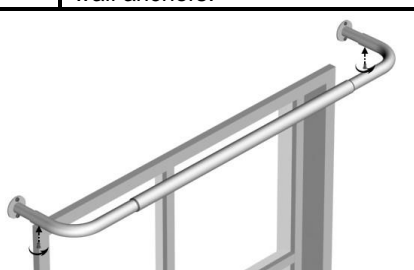
| | | | |
|---|---|--|---|
|  |  |  | |
| <p>1). Loosen set screws on the return rod to remove the Barrel Brackets (as shown).</p> | <p>2). Using the Barrel Bracket as a template place it in desired position. Mark holes.</p> | <p>3). Drill 3/16" holes and insert wall anchors.*</p> | |
|  |  |  |  |
| <p>4). Screw Barrel Brackets to wall with screw. Using level, repeat for the other side.</p> | <p>5). Slide rods onto the Barrel Brackets. Tighten set screws</p> | | <p>5). Slide rods onto the Barrel Brackets. Tighten set screws</p> |
| <p>This completes the 28"-48 or 30"-52" rod set</p> | <p>Rod 48"-84" 52"-96" 84"-120" or 96"-144" may require a Center Support Bracket. Install rod to Barrel Bracket. Position Center Support Bracket and mark holes. Remove rod. Follow step 3 and screw center bracket base to wall. Slide rod onto Barrel Brackets and insert center support bracket extension. Tighten set screws.</p> | | |

Note: * Depending on the type of wall where this rod set is installed it may require using mounting hardware such as Toggle Bolts or hollow wall anchors (not included). Follow all above instructions replacing the anchors with proper fastener.